



**pennsylvania**  
DEPARTMENT OF EDUCATION

# The Pennsylvania System of School Assessment

## Mathematics Item and Scoring Sampler



2015–2016  
Grade 6

## TABLE OF CONTENTS

Introduction .....	1
Mathematics Reporting Categories .....	2
General Description of Scoring Guidelines for Mathematics Open-Ended Questions. . . .	3
Description of Sample Questions. ....	4
Mathematics Formula Sheet. ....	5
Multiple-Choice Questions. ....	7
First Open-Ended Question .....	40
Item-Specific Scoring Guideline. ....	43
First Open-Ended Question Responses. ....	45
Second Open-Ended Question .....	60
Item-Specific Scoring Guideline. ....	62
Second Open-Ended Question Responses .....	64
Third Open-Ended Question. ....	74
Item-Specific Scoring Guideline. ....	76
Third Open-Ended Question Responses .....	78
Fourth Open-Ended Question .....	88
Item-Specific Scoring Guideline. ....	90
Fourth Open-Ended Question Responses .....	92
Fifth Open-Ended Question .....	102
Item-Specific Scoring Guideline. ....	104
Fifth Open-Ended Question Responses. ....	106

# INTRODUCTION

## General Introduction

The Pennsylvania Department of Education provides districts and schools with tools to assist in delivering focused instructional programs aligned with the Pennsylvania Core Standards (PCS). These tools include Academic Standards, Assessment Anchor documents, assessment handbooks, and content-based item and scoring samplers. This Item and Scoring Sampler is a useful tool for Pennsylvania educators in preparing local instructional programs. It can also be useful in preparing students for the statewide assessment.

## Pennsylvania Core Standards (PCS)

This sampler contains examples of test questions that are aligned to the new Pennsylvania Core Standards-based 2013 PSSA Assessment Anchors and Eligible Content. The Mathematics, Reading, and Writing PSSA transitioned to PCS-based operational Mathematics and English Language Arts assessments starting with the spring 2015 PSSA administration.

The 2013 PCS-aligned Assessment Anchor and Eligible Content documents are posted on this portal:

- [www.education.pa.gov](http://www.education.pa.gov) [Hover over “K–12,” select “Assessment and Accountability,” and select “Pennsylvania System of School Assessment (PSSA).” Then select “Assessment Anchors” from the “Other Materials” list on the right side of the screen.]

## What Is Included

This sampler contains test questions (items) that have been written to align to the Assessment Anchors that are based on the Pennsylvania Core Standards (PCS). The test questions provide an idea of the types of items that will appear on an operational, PCS-based PSSA. Each sample test question has been through a rigorous review process to ensure alignment with the Assessment Anchors.

## Purpose and Uses

The items in this sampler may be used as examples for creating assessment items at the classroom level, and they may also be copied and used as part of a local instructional program.<sup>1</sup> Classroom teachers may find it beneficial to have students respond to the open-ended items in this sampler. Educators can then use the sampler as a guide to score the responses either independently or together with colleagues within a school or district.

## Item Format and Scoring Guidelines

The multiple-choice (MC) items have four answer choices. Each correct response to an MC item is worth one point.

Each open-ended (OE) item is designed to take approximately ten to fifteen minutes to complete. During the administration of the PSSA, students are given additional time as necessary to complete the test items. Each OE item in mathematics is scored using an item-specific scoring guideline based on a 0–4 point scale. In this sampler, every item-specific scoring guideline is combined with examples of student responses that represent each score point to form a practical, item-specific scoring guide.

The sampler also includes the *General Description of Scoring Guidelines for Mathematics Open-Ended Questions* that students will have access to during a PSSA mathematics administration. The general description of scoring guidelines can be distributed to students for use during local assessments and can also be used by educators when scoring local assessments.<sup>1</sup>

---

<sup>1</sup> The permission to copy and/or use these materials does not extend to commercial purposes.

## Item Alignment

All PSSA items are aligned to statements and specifications included in the *Assessment Anchors and Eligible Content Aligned to the Pennsylvania Core Standards*. The mathematics content, process skills, directives, and action statements included in the PSSA mathematics questions align with the Assessment Anchor Content Standards. The Eligible Content statements represent the limits of the content of the mathematics questions.

## Testing Time and Mode of Testing Delivery for the PCS-Based PSSA

The PSSA is delivered in traditional paper-and-pencil format as well as in an online format. The estimated time to respond to a test question is the same for both methods of test delivery. During an official testing administration, students are given additional time as necessary to complete the test questions. The following table shows the estimated response time for each item type.

Item Type	MC	OE
Estimated Response Time (in minutes)	2	10 to 15

## MATHEMATICS REPORTING CATEGORIES

The Assessment Anchors are organized into four classifications, as listed below.

- A = Numbers and Operations
- B = Algebraic Concepts
- C = Geometry
- D = Data Analysis and Probability

These four classifications are used throughout the grade levels. In addition to these classifications, there are five Reporting Categories for each grade level. The first letter of each Reporting Category represents the classification; the second letter represents the Domain as stated in the Common Core State Standards for Mathematics. Listed below are the Reporting Categories for Grade 6.

- A-N = The Number System
- A-R = Ratios and Proportional Relationships
- B-E = Expressions and Equations
- C-G = Geometry
- D-S = Statistics and Probability

Examples of multiple-choice and open-ended items assessing these categories are included in this booklet.

## **GENERAL DESCRIPTION OF SCORING GUIDELINES FOR MATHEMATICS OPEN-ENDED QUESTIONS**

- 4 – The response demonstrates a *thorough* understanding of the mathematical concepts and procedures required by the task.**

The response provides correct answer(s) with clear and complete mathematical procedures shown and a correct explanation, as required by the task. Response may contain a minor “blemish” or omission in work or explanation that does not detract from demonstrating a *thorough* understanding.

- 3 – The response demonstrates a *general* understanding of the mathematical concepts and procedures required by the task.**

The response and explanation (as required by the task) are mostly complete and correct. The response may have minor errors or omissions that do not detract from demonstrating a *general* understanding.

- 2 – The response demonstrates a *partial* understanding of the mathematical concepts and procedures required by the task.**

The response is somewhat correct with *partial* understanding of the required mathematical concepts and/or procedures demonstrated and/or explained. The response may contain some work that is incomplete or unclear.

- 1 – The response demonstrates a *minimal* understanding of the mathematical concepts and procedures required by the task.**

- 0 – The response has no correct answer and *insufficient* evidence to demonstrate any understanding of the mathematical concepts and procedures required by the task for that grade level.**

Response may show only information copied from the question.

## **DESCRIPTION OF SAMPLE QUESTIONS**

The mathematics multiple-choice questions begin on page 7. Each question is preceded by the Assessment Anchor and Eligible Content coding to which it aligns. Incorrect answer options are followed by the “rationale” which supports the student’s response. All correct answer options are indicated by an asterisk (\*).

Five open-ended questions follow the multiple-choice questions. Each open-ended question includes question-specific scoring guidelines and examples of student responses with scores and annotations.

Since the PSSA is delivered in both paper-and-pencil and online formats, OE items of each method of test delivery are included in this sampler. The online OE sample items are presented as screen shots in a landscape orientation in order to best approximate the view of a computer monitor. The examples of student responses that follow the online OE sample items are also presented as screen shots.

A calculator is permitted for use in solving questions numbered 4–50 in this sampler. Questions numbered 1–3 are to be solved without the use of a calculator. Scratch paper may be used in solving all questions.

## MATHEMATICS FORMULA SHEET

Below is a Mathematics formula sheet that will be available to students during the test. The formula sheet reflects the mathematical approach included in the Assessment Anchors that are based on the Pennsylvania Core Standards (PCS). The formula sheet is also available in Spanish.

Formulas that you may need to work questions on this test are found below.  
You may refer back to this page at any time during the mathematics test.

2016  
Grade 6

### Triangle

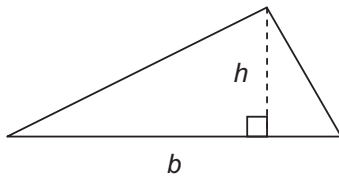

$$A = \frac{1}{2}bh$$

### Rectangle

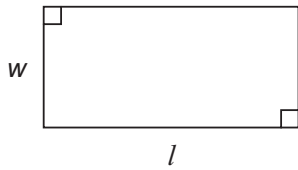

$$A = lw$$

### Square

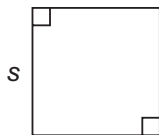

$$A = s^2$$

### Parallelogram

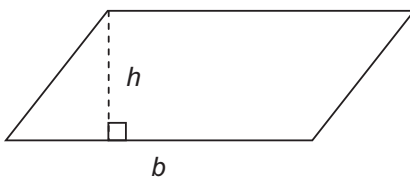

$$A = bh$$

### Trapezoid

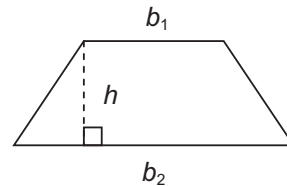

$$A = \frac{1}{2}h(b_1 + b_2)$$

### Rectangular Prism

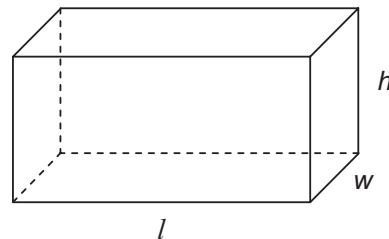

$$V = lwh$$

$$SA = 2lw + 2lh + 2wh$$

### Cube

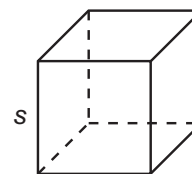

$$V = s \cdot s \cdot s$$

$$SA = 6s^2$$

### Triangular Prism

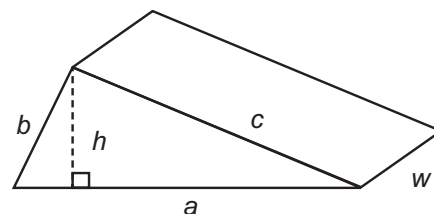

$$SA = ah + aw + bw + cw$$

On the following pages are the mathematics questions.

- You may not use a calculator for questions 1–3. You may use a calculator for all other questions on this test.

**Directions for Multiple-Choice Questions:**

Some questions will ask you to select an answer from among four choices.

For the multiple-choice questions:

- First solve the problem on scratch paper.
- Choose the correct answer and record your choice in the answer booklet.
- If none of the choices matches your answer, go back and check your work for possible errors.
- Only one of the answers provided is the correct response.

**Directions for Open-Ended Questions:**

Some questions will require you to write your response.

For the open-ended questions:

- These questions have more than one part. Be sure to read the directions carefully.
- You cannot receive the highest score for an open-ended question without completing all tasks in the question. For example, if the question asks you to show your work or explain your reasoning, be sure to show your work or explain your reasoning in the space provided.
- If the question does **not** ask you to show your work or explain your reasoning, you may use the space provided, but only those parts of your response that the question specifically asks for will be scored.
- Write your response in the appropriate location within the response box in the answer booklet. Some answers may require graphing, plotting, labeling, drawing, or shading. If you use scratch paper, be sure to transfer your final response and any needed work or reasoning to the answer booklet.



## MULTIPLE-CHOICE QUESTIONS

You may not use a calculator for questions 1–3.

## A-N.1.1.1

1. Divide:  $58\frac{1}{3} \div 6\frac{2}{3}$

A.  $7\frac{3}{8}$

*incorrectly converts  $58\frac{1}{3}$  to  $59\frac{1}{3}$  and  $6\frac{2}{3}$  to  $8\frac{2}{3}$  (i.e., does not multiply the whole number by the denominators, before adding to the numerators)*

B.  $8\frac{3}{4}$

\*

C.  $9\frac{2}{3}$

*divides whole numbers and does not use fractions*

D.  $10\frac{1}{6}$

*divides whole numbers ( $58 \div 6 = 9\frac{2}{3}$ ), divides fractions ( $1\frac{1}{3} \div 2\frac{2}{3} = 1\frac{1}{2}$ ), then adds the quotients*

## A-N.2.1.1

2. Aaron wants to buy 2 concert tickets that cost \$25.50 each. Aaron's grandfather pays him \$4.25 an hour to rake leaves. How many hours does Aaron have to rake leaves to earn the total cost of the tickets?

A. 1.2

*misplaces decimal when dividing*

B. 6

*divides 25.50 by 4.25 (ignores the factor 2)*

C. 12

\*

D. 16.5

*computes  $25.50/4.25$  incorrectly as  $25/4 + 0.50/0.25$ , then multiplies this result by 2*

## A-N.2.1.1

3. Multiply:  $2.5 \times 3.5 \times 0.01$

- A. 0.0625  $(2 \times 3 + 0.5 \times 0.5) \times 0.01$
- B. 0.0875 \*
- C. 0.625  $(2 \times 3 + 0.5 \times 0.5) \times 0.1$
- D. 0.875 *does not move the decimal enough places*

A calculator is permitted for use in solving questions numbered 4–50 in this sampler.

## A-N.1.1.1

4. Emily is making bows using ribbon. She has two pieces of ribbon to use. One is 23 yards long. The other is  $4\frac{1}{4}$  yards long. She needs  $1\frac{5}{6}$  yards of ribbon to make each bow. What is the **greatest** number of bows Emily can make?

- A. 12 *number of bows for longer piece only*
- B. 14 \*
- C. 15 *adds before dividing by  $1\frac{5}{6}$  and assumes fractional part is enough for 1 more bow*
- D. 19 *correctly calculates 12 bows from longer piece; incorrectly divides for shorter piece:  $17\frac{1}{4} \times 1\frac{1}{6} = 7.79\dots$ , then adds  $7+12$*

A-N.1.1.1

A-N.2.1.1

5. Izara built a fence for her horses. The fence was 210 feet long. She put a fence post in the ground at the start of the fence and another fence post every  $3\frac{1}{2}$  feet. Izara paid \$8.50 for each fence post. How much did Izara pay for all the fence posts she used?

A. \$297.50

*divides by 3 first, then takes half of that to find number of fence posts*

B. \$518.50

\*

C. \$595.00

*makes error in changing to improper fraction (6/2)*

D. \$765.00

*makes error in changing to improper fraction (7/3)*

## A-N.2.2

6. An art teacher makes a supply package containing sheets of red paper and sheets of green paper for each student in a class.
- There are 84 sheets of red paper and 96 sheets of green paper available for the packages.
  - Each package has the same number of sheets of red paper.
  - Each package has the same number of sheets of green paper.
  - The maximum number of packages are made.
  - There are no sheets of paper remaining.

What are the maximum number of packages that can be made and the numbers of sheets of red paper and green paper in each package?

- A. 6 packages with 14 sheets of red paper and 16 sheets of green paper

*a number that could be made, but not the maximum*

- B. 12 packages with 7 sheets of red paper and 8 sheets of green paper

\*

- C. 12 packages with 12 sheets of red paper and 12 sheets of green paper

*correct maximum number, but also uses maximum number as numbers of sheets of red paper and green paper*

- D. 24 packages with 3 sheets of red paper and 4 sheets of green paper

*works for green paper, but not for red paper as 24 is not a factor of 84*

A-N.2.2.1

A-N.2.2.2

7. Gracie is rewriting the expression  $(24 + 40)$  as an integer times the sum of two integers. By factoring out a 2, she knows she can rewrite the expression as 2 times the sum of two integers. What are all the other numbers greater than 2 that Gracie can factor out of  $(24 + 40)$  to rewrite the expression as an integer times the sum of two integers?

A. 4, 8

\*

B. 4, 6, 8

*correctly lists 4 and 8, but also lists 6 since it is part of the factor pair (along with 4) of 24*

C. 3, 5, 6, 10, 12, 20

*lists all of the non-common factors for 24 and 40*

D. 3, 4, 5, 6, 8, 10, 12, 20

*lists all the factors of 24 and 40*

A-N.3.1

8. The price of a gallon of gasoline decreased by \$0.04. Which number line shows a point that represents the change in the price of a gallon of gasoline, in dollars?

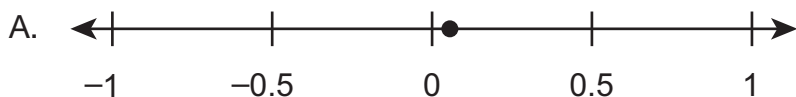

*considers it positive*

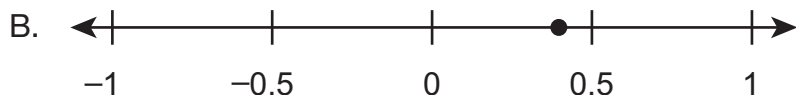

*considers it positive and is confused about relative size of 0.04*

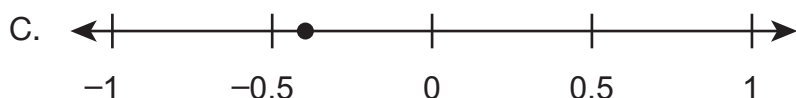

*is confused about relative size of -0.04*

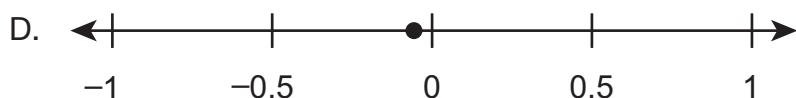

\*

A-N.3.2.1

A-N.3.1.3

9. Four points are graphed on the number line below.

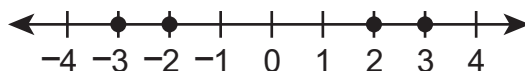

Which inequality correctly compares numbers that can be represented by the points?

A.  $-3 < |-3| < -2 < |-2|$

*compares opposites correctly but compares 3 and 2 as though they were -3 and -2*

B.  $|-2| < -2 < |-3| < -3$

*misinterprets meaning of absolute value, orders by magnitude*

C.  $-(-3) < -(-2) < -|2| < -|3|$

*reverses positives and negatives by misinterpreting opposites and absolute values*

D.  $-|3| < -|2| < -(-2) < -(-3)$  \*

A-N.3.2.2

A-N.3.2.1

10. Quincy and Ray keep track of their scores in a game. The person with the greater score is winning the game. Quincy has a score of  $-70$ , and Ray has a score of  $-60$ . Which statement **best** explains who is winning and how many points away from 0 that person is?

A. Ray is winning and needs to lose 60 points to get to 0.

*thinks  $-60 - 60 = 0$*

B. Ray is winning and needs to gain 60 points to get to 0.

\*

C. Quincy is winning and needs to lose 70 points to get to 0.

*thinks  $-70 > -60$  and  $-70 - 70 = 0$*

D. Quincy is winning and needs to gain 70 points to get to 0.

*thinks  $-70 > -60$*

A-N.3.2.3

A-R.1.1.4

11. On the coordinate grid below, point J shows the starting location of Jake and point L shows the starting location of Lisa.

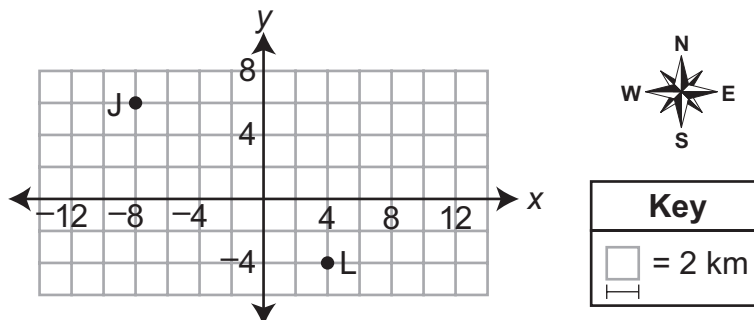

- Jake walks from his starting location for the same amount of time as Lisa walks from her starting location.
- Jake walks east at an average rate of 4 kilometers per hour.
- Lisa walks west at an average rate of 3 kilometers per hour.
- Jake stops walking when he reaches the point directly north of point L.

Which ordered pair describes the location of Lisa when she stops walking?

A.  $(-12, -4)$

*uses 3 km/hr as Jake's rate and reasons that  $12/3 = 4$  hr; then calculates Lisa's distance as  $4 \times 4 = 16$*

B.  $(-8, -4)$

*assumes that Lisa moves the same distance as Jake because they move for the same amount of time*

C.  $(-5, -4)$   
\*

D.  $(-3, -4)$

*correctly locates stopping point of Lisa, but uses number on the wrong side of -4 when writing ordered pair*



A-R.1.1

12. At a factory, a machine tests 1 out of every 75 items produced for quality. The machine requires a safety check after testing 450 items. The factory produces 303,750 items each month. How many safety checks does the machine require each month?

- A. 6 *450/75; does not account for the number of items produced each month*
- B. 9 \*
- C. 50 *finds correct number of safety checks, but then divides 450/9*
- D. 54 *finds number of items quality tested, then divides 4,050/75*

A-R.1.1.1

13. The ratio of the number of giraffes to the number of monkeys in a zoo is 2 to 5. Which statement about the giraffes and monkeys could be true?

- A. For every giraffe in the zoo, there are 10 monkeys. *multiplies numbers in ratio*
- B. For every 10 giraffes in the zoo, there is 1 monkey. *multiplies numbers in ratio*
- C. For every 4 giraffes in the zoo, there are 10 monkeys. \*
- D. For every 10 giraffes in the zoo, there are 4 monkeys. *reverses ratio*

**A-R.1.1.3**

14. A company is assembling packages of life jackets for boats. The table below shows the number of children’s life jackets and the number of adult life jackets in some different packages.

**Contents of Life Jacket Packages**

Number of Children’s Size	Number of Adult Size
2	6
4	12
7	21

The ratio of the number of children’s life jackets to the number of adult life jackets in each package is constant. Based on the information shown in the table, which two ratios could also be included in the table?

- |                               |                                                                  |                                 |                                                                                        |
|-------------------------------|------------------------------------------------------------------|---------------------------------|----------------------------------------------------------------------------------------|
| <p>A. 28 : 32<br/>31 : 35</p> | <p><i>2+4=6, so uses a difference of 4 for new ratios</i></p>    | <p>B. 11 : 22<br/>16 : 32</p>   | <p><i>4 is double 2, and 12 is double 6, so doubles first number in new ratios</i></p> |
| <p>C. 13 : 27<br/>22 : 36</p> | <p><i>7+14=21, so uses a difference of 14 for new ratios</i></p> | <p>D. 10 : 30 *<br/>17 : 51</p> |                                                                                        |

**A-R.1.1.4**

15. Katie’s goal is to read 6 books every 3 months. Based on this goal, how many months will it take Katie to read 24 books?

- |              |                                                        |
|--------------|--------------------------------------------------------|
| <p>A. 4</p>  | <p><i>divides 24 by 6</i></p>                          |
| <p>B. 8</p>  | <p><i>divides 24 by 3</i></p>                          |
| <p>C. 12</p> | <p>*</p>                                               |
| <p>D. 18</p> | <p><i>multiplies 6 by 3 or subtracts 6 from 24</i></p> |

## A-R.1.1.5

16. When a farmer harvests chicken eggs, he expects 2% of the eggs to be cracked. How many eggs would the farmer expect to be cracked when harvesting 350 eggs?

- A. 3
- B. 7 \*
- C. 18
- D. 70

## B-E.1

17. Kent thinks that  $x + x$  and  $x^2$  are equivalent expressions because they each have a value of 4 when  $x = 2$ . Which statement **best** demonstrates whether Kent is correct?

- A. Kent is correct because  $x + x$  is the same as  $2x$ , and  $2x$  is the same as  $x^2$ .
- B. Kent is correct because the two expressions are also equivalent when  $x = 0$ .
- C. Kent is **not** correct because the two expressions do not have the same value at  $x = 1$ .  
\*
- D. Kent is **not** correct because expressions can never be equivalent if they use different operations.

**B-E.1.1**  
**A-R.1.1.2**

18. Alex and Payton each have a favorite pancake recipe.

- Alex’s recipe uses  $7\frac{1}{2}$  cups of flour for 5 batches.
- Payton’s recipe uses  $\frac{3}{4}$  cup of flour more per batch than Alex’s recipe uses per batch.

Which expression can be used to determine the number of cups of flour used to make  $x$  batches of Payton’s pancake recipe?

- A.  $2\frac{1}{4}x$  \*
- B.  $8\frac{1}{4}x$  *adds  $7\frac{1}{2}$  and  $\frac{3}{4}$  to find unit rate for Payton’s recipe*
- C.  $1\frac{1}{2}x + \frac{3}{4}$  *calculates unit rate for Alex’s recipe, multiplies by  $x$ , and then adds  $\frac{3}{4}$*
- D.  $7\frac{1}{2}x + \frac{3}{4}$  *multiplies  $x$  by total number of cups of flour for 5 batches of Alex’s recipe, then adds  $\frac{3}{4}$*

**B-E.1.1.2**  
**A-N.2.2.2**

19. This soccer season, Gavin scored 9 fewer than 3 times the number of goals that Rico scored. Rico scored 12 goals. The value of which expression is equivalent to the number of goals Gavin scored this soccer season?

- A.  $3(4 - 3)$  *subtracts before multiplying; factors a 3 from 12 and 9 but does not account for it*
- B.  $3(12 - 9)$  *subtracts before multiplying*
- C.  $9(4 - 1)$  \*
- D.  $9(36 - 1)$   *$3 \times 12 - 9$ , but does not factor 9 from 36*

## B-E.1.1.4

20. Jenae goes to the store to buy a jacket. The store is having a sale for 30% off the original price of the jackets. Jenae also has a \$10-off coupon she will use to buy the jacket. The expression below can be used to find her final price for a jacket with an original price of  $p$  dollars.

$$0.7p - 10$$

The jacket Jenae decides to buy has an original price of  $p = \$87.99$ . What is the final price of the jacket Jenae is buying?

- A. \$51.59 \*
- B. \$54.59 *wrong order of operations, subtracts first*
- C. \$71.59 *adds instead of subtracts*
- D. \$84.99  $\$87.99 + 7 = \$94.99 - 10$

## B-E.1.1.5

21. Each weekday, a factory produces 16 truckloads of canned corn and 12 truckloads of canned peas. The expression  $5(16 + 12)$  represents the total number of cans produced each week by the factory. Which expression also represents the total number of cans produced each week by the factory?

- A.  $21 + 12$  *adds 5 to 16*
- B.  $21 + 17$  *adds 5 to both 16 and 12*
- C.  $80 + 12$  *only multiplies 16 by 5*
- D.  $80 + 60$  \*

## B-E.1.1.5

22. Mrs. Seager's daughter is  $y$  years old. Mrs. Seager's age, in years, can be represented by the expression  $6y - 4$ . Which expression also represents Mrs. Seager's age, in years?

- A.  $2(3y - 4)$  *forgets to divide the -4 by 2*
- B.  $2(3y - 2)$  \*
- C.  $3(2y - 1)$  *subtracts 3 from 4 instead of dividing 4 by 3*
- D.  $3(2y - 4)$  *forgets to divide the second term 4 by the factor of 3*

## B-E.1.1.5

## B-E.1.1.3

23. Which expression uses exactly three terms and is equivalent to  $6(2 + x + x + y)$ ?

- A.  $8 + 8x + 7y$  *picks one with three terms but adds 6 instead of multiplying by 6*
- B.  $12 + 12x + 6y$  \*
- C.  $8 + 6x + 6x + 6y$  *adds 6 and 2 and appends the 6 in front of each variable*
- D.  $12 + 6x + 6x + 6y$  *thinks there are only three terms because the student only counts the terms with variables in them*

## B-E.2.1

24. Mr. Aarav paid a total of \$588 to stay in a hotel and park his car for 3 nights. Each night, the hotel charged Mr. Aarav  $h$  dollars for a room and \$15 for parking. The equation shown below represents the total amount, in dollars, Mr. Aarav paid for the 3 nights.

$$3(h + 15) = 588$$

How much was Mr. Aarav charged for the room for 1 night?

- A. \$181 \*
- B. \$191
- C. \$201
- D. \$211

## B-E.2.1.3

25. Michael has \$68. Craig has \$24 less than Michael has. Michael spends \$20 on a new hat. The solution of which equation represents the amount of money ( $x$ ), in dollars, Craig has after Michael buys the hat?

- A.  $x + 4 = 48$  \*
- B.  $x + 4 = 68$
- C.  $x + 20 = 44$
- D.  $x + 24 = 48$

**B-E.2.1.4**

26. Sergei knows the bicycle he wants to buy will cost more than \$84.00. He has already saved \$26.75 for the bicycle. His aunt has given him \$20.00 to use to buy the bicycle. Which inequality describes all of the additional amounts of money ( $m$ ), in dollars, that Sergei could save to be able to buy the bicycle?

- A.  $m > 37.25$  \*
- B.  $m > 46.75$  *adds savings and gift, but does not subtract from 84.00*
- C.  $m > 57.25$  *84.00 - 26.75 = 57.25; uses only saved money*
- D.  $m > 84.00$  *inequality describes cost of bicycle*

**B-E.3**

27. A relationship is described below.

For every 6 inches of border used around a bulletin board, 2 pushpins are used.

Which statement about the dependent variable in the relationship is true?

- A. The length of border used is the dependent variable because it is determined by the number of pushpins used.  
*border is independent variable*
- B. The length of border used is the dependent variable because it is not determined by the number of pushpins used.  
*border is independent variable*
- C. The number of pushpins used is the dependent variable because it is determined by the length of border used.  
\*
- D. The number of pushpins used is the dependent variable because it is not determined by the length of border used.  
*thinks border and pushpins are unrelated*



B-E.3.1.1

C-G.1.1.6

28. Carlos makes wooden boxes without tops to use as flower planters. Each wooden box has a width of 14 inches and a height of 24 inches. The length of the box ( $x$ ) varies depending on the types of flowers Carlos will plant. A picture of a wooden box is shown below.

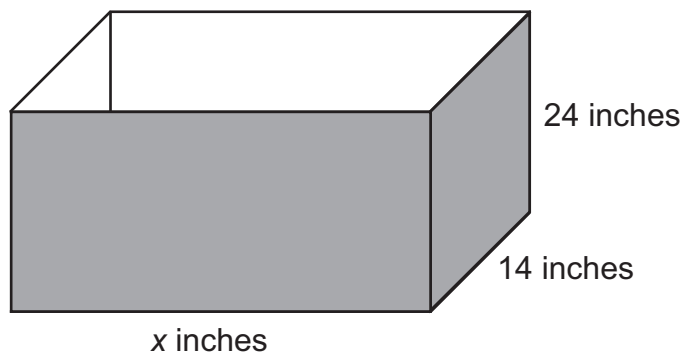

Which equation can be used to find the surface area ( $y$ ), in square inches, of a wooden box that has a length of  $x$  inches?

A.  $y = 38 + x$

<i>adds the three dimensions</i>
----------------------------------

B.  $y = 336x$

<i>multiplies the three dimensions</i>
----------------------------------------

C.  $y = 672 + 62x$

\*

D.  $y = 672 + 76x$

<i>includes the area of the top of the box</i>
------------------------------------------------

## B-E.3.1.2

29. The table below shows the relationship between the number of buses used on a field trip and the maximum number of riders.

Field Trip Buses

Number of Buses ( $b$ )	Maximum Number of Riders ( $r$ )
3	120
4	160
5	200
6	240

Which equation describes the relationship shown in the table?

A.  $r = b + 40$

*recognizes the pattern in the 2nd column as +40*

B.  $r = 3b + 120$

*uses first row of values in equation*

C.  $r = 40b$

\*

D.  $r = 117b$

$120 - 3 = 117$

B-E.3.1.2

30. The temperature in Dylan’s freezer, in degrees Fahrenheit (°F), over several hours in an afternoon is shown in the graph below.

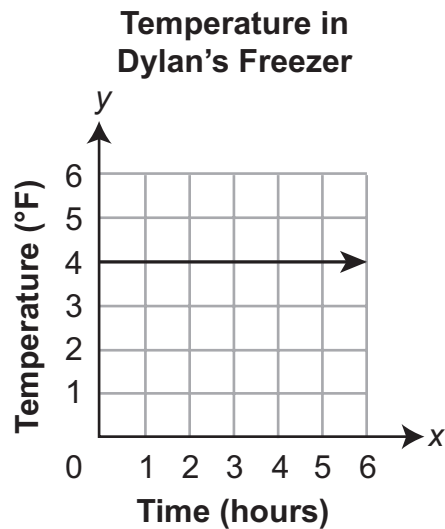

Which equation can be used to determine the temperature, in degrees Fahrenheit, of Dylan’s freezer?

- A.  $x = 4$  *wrong axis*
- B.  $y = 4$  \*
- C.  $x = y + 4$  *slope is 0, x should not be in the equation at all*
- D.  $y = x + 4$  *slope is 0, the value of x does not change the slope and is not part of the equation*

## C-G.1.1

31. A birdhouse is shaped like a rectangular prism. A circular hole is cut out of the front of the birdhouse for the entrance, as represented in the picture below.

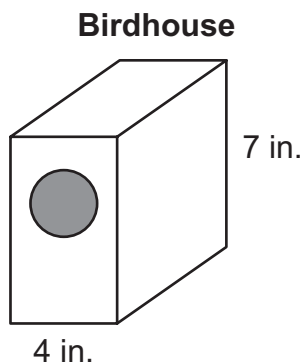

- The volume of the birdhouse is 140 cubic inches.
- The hole has an area that is  $\frac{1}{4}$  the area of the top of the birdhouse.

Alicia paints the outside of the birdhouse. How many square inches does Alicia paint?

A. 156

*subtracts 1/4 the combined area of the top and bottom of the birdhouse from the surface area of the rectangular prism*

B. 159

*calculates area of top of birdhouse as the product of 4 and 7 when calculating area of the hole*

C. 161

\*

D. 166

*calculates surface area but does not subtract area of the hole*

C-G.1.1.2

C-G.1.1.4

32. The coordinates of the vertices of a quadrilateral are given below.

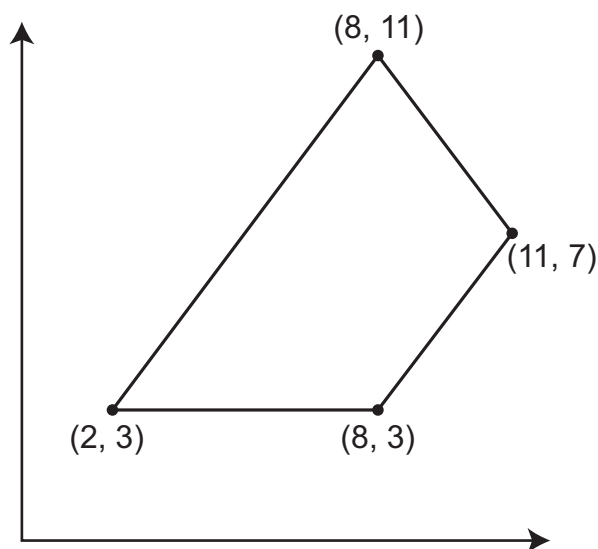

What is the area, in square units, of the quadrilateral?

A. 24 square units

*finds area of right triangle, then doubles it for full area (split into 2 triangles)  
OR applies 1/2 from triangle area formula to the parallelogram (split into triangle + parallelogram)*

B. 36 square units

\*

C. 48 square units

*finds area of left triangle, then doubles it for full area OR does not apply 1/2 from triangle area formula (split into triangle + parallelogram)*

D. 72 square units

*splits into two triangles, but does not apply the 1/2 when finding the areas*

C-G.1.1.2

C-G.1.1.4

33. A triangle and a trapezoid are graphed on the coordinate plane shown below.

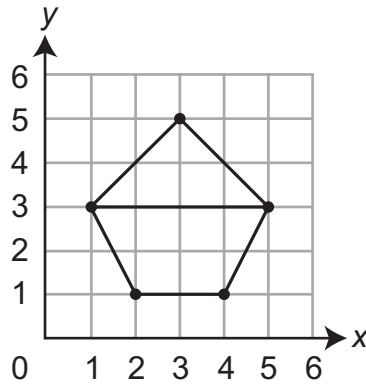

What is the combined area, in square units, of the two shapes?

- A. 10      \*
- B. 14      *adds 6 + 8; does not multiply by 1/2 for area of triangle*
- C. 16      *does not decompose; multiplies 4 × 4 for height and width*
- D. 20      *adds 12 + 8; does not multiply by 1/2 for area of trapezoid or triangle*

## C-G.1.1.3

34. Jamal keeps different colors of beads in containers shaped like the one shown below.

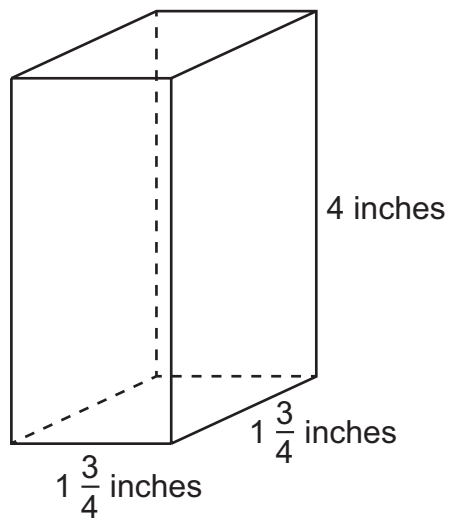

What is the volume, in cubic inches, of one of these containers?

- A.  $4 \frac{9}{16}$  *multiplies the whole numbers and fractions separately*
- B.  $7 \frac{1}{2}$  *adds the dimensions*
- C.  $12 \frac{1}{4}$  \*
- D. 14 *adds the identical dimensions and multiplies by 4*

C-G.1.1.4

C-G.1.1.6

35. Phil is making a number cube out of cardboard. He traces one face of the number cube onto a coordinate grid. The coordinates of two opposite vertices of the face are (4, 8) and (12, 16). What is the surface area, in square units, of Phil's entire number cube?

- A. 48
- B. 64
- C. 384 \*
- D. 512



C-G.1.1.6

B-E.2.1.3

36. Neelah received a package in the shape of a rectangular prism as shown below.

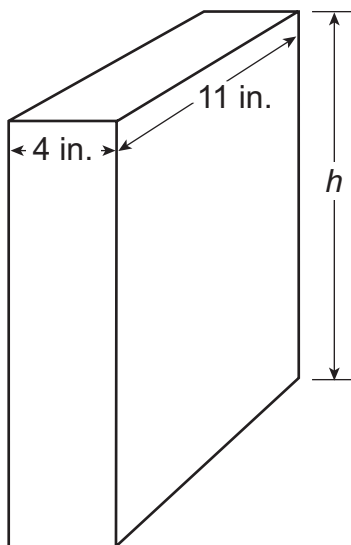

The volume of the package is 748 cubic inches. The equation  $4 \times 11 \times h = 748$  can be used to find the height ( $h$ ), in inches, of the package. What is the surface area, in square inches, of Neelah's package?

- A. 299
- B. 418
- C. 510
- D. 598 \*

D-S.1

37. Coach Jansen records the number of miles each of his 10 students ran last week. Some information about the numbers of miles is listed below.

- The **mean** number of miles run by the students is 5.
- The **median** number of miles run by the students is also 5.

Which line plot could show the numbers of miles the 10 students ran last week?

A.

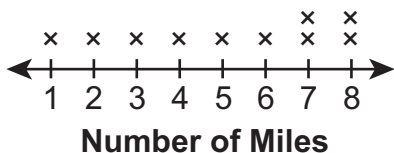

*mean = 5.1; median = 5.5*

B.

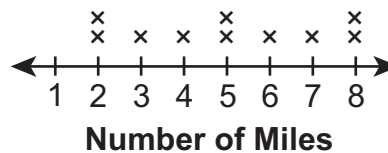

\*

C.

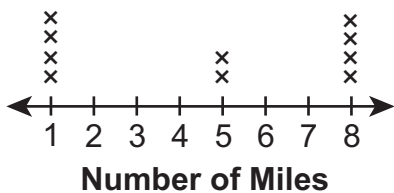

*median = 5; mean = 4.6*

D.

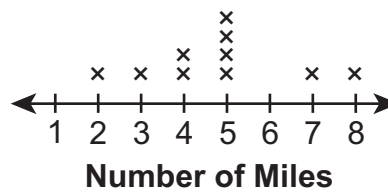

*median = 5; mean = 4.8*

D-S.1

38. Matthew asked 10 students how many pets and how many siblings each has. The line plots below show his data.

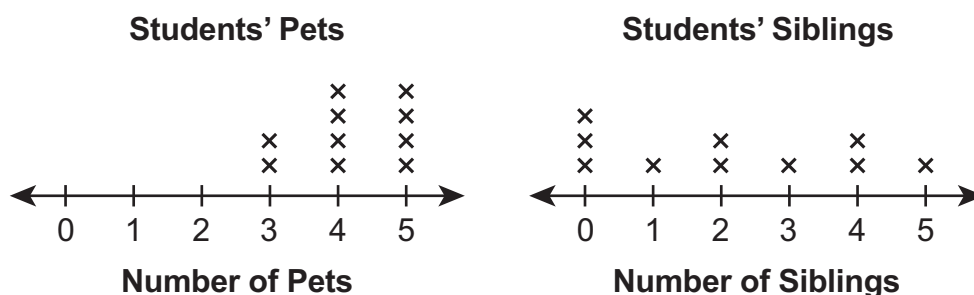

Which statement correctly describes Matthew's data?

- A. The median number of pets the students have is less than the median number of siblings the students have.

*incorrectly identifies the median*

- B. There is less variability in the number of pets the students have than in the number of siblings the students have.

\*

- C. The range in the number of siblings the students have is less than the range in the number of pets the students have.

*incorrectly computes the range*

- D. The mean absolute deviation of the number of siblings the students have is less than the mean absolute deviation of the number of pets the students have.

*thinks smaller data points result in less deviation from the mean*

D-S.1.1

39. A data set contains eight numbers. Only four of the numbers are known. When the eight numbers are ordered from **least** to **greatest**, the unknown numbers can be placed into the blanks of the ordered list shown below.

19.2    \_\_\_\_\_    \_\_\_\_\_    20.4    26.0    \_\_\_\_\_    \_\_\_\_\_    30.8

Which box-and-whisker plot could represent the data set?

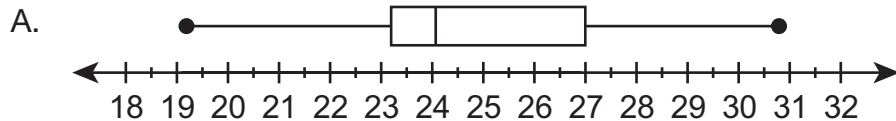

*uses average of 4 given numbers as median; does not consider how size of missing values relates to size of given values when determining possible Q1*

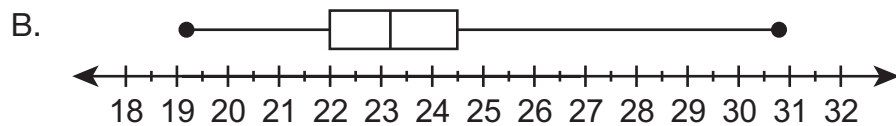

*does not consider how size of missing values relates to size of given values when determining possible Q1 and Q3*

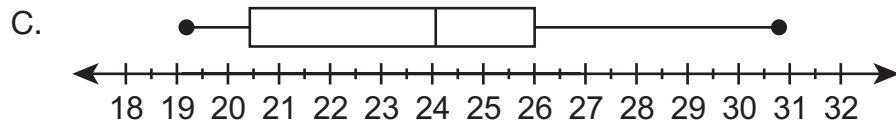

*uses average of 4 given numbers as median*

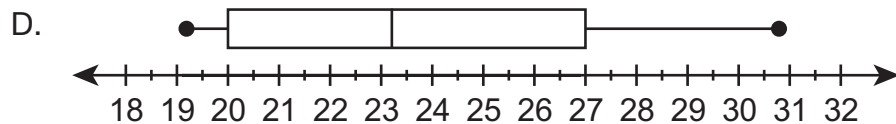

\*

D-S.1.1.1

40. Yvonne and her family went on a 10-day fishing trip. The data set below shows the number of fish they caught each day.

14 4 8 16 7 12 10 11 10 9

Which box-and-whisker plot represents the number of fish Yvonne and her family caught on their fishing trip?

A.

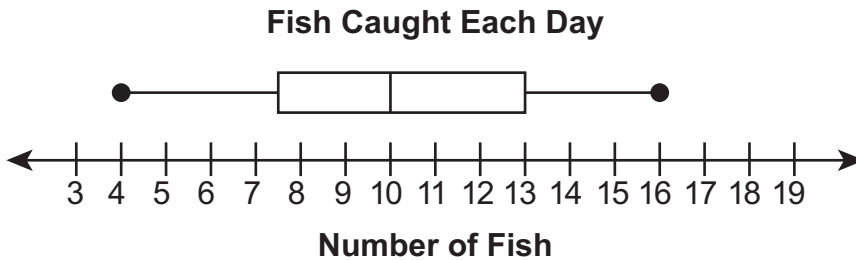

does not reorder

B.

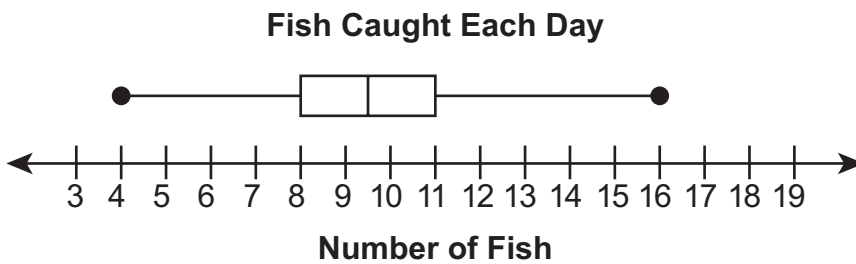

leaves out a 10

C.

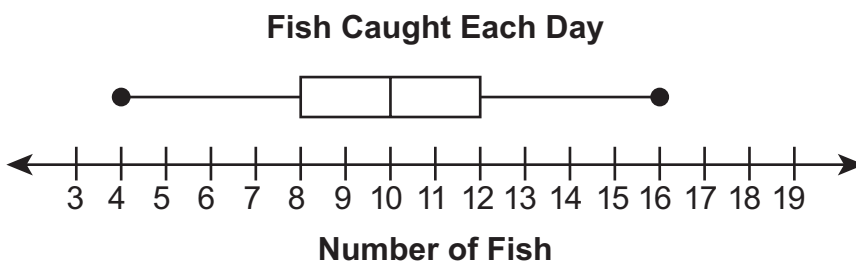

\*

D.

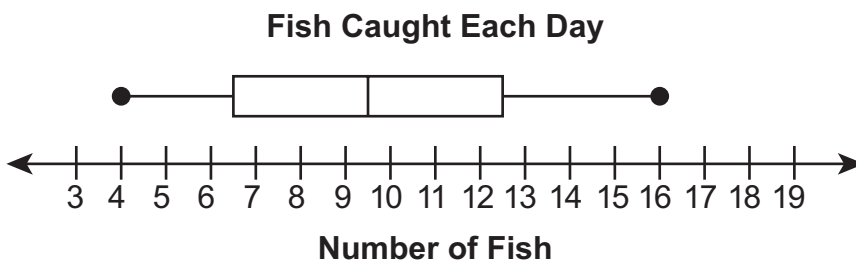

does not order data and thinks box must be symmetric about the median

D-S.1.1.1

41. Malik interviewed 20 people who each have just one sibling. He asked them what the difference in age, in years, is between them and their siblings. The line plot below shows Malik's data.

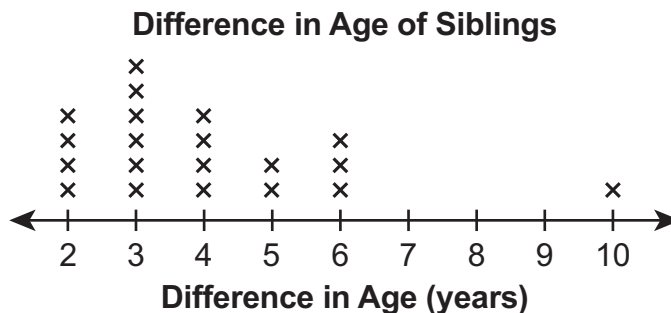

Malik removes the point representing the 10-year age difference from his data. Which measure changes the **least** in value when this point is removed from Malik's data?

- A. mean *incorrect, mean changes as it is affected by outliers*
- B. median *thinks median is never affected by outliers*
- C. mode \*
- D. range *incorrect, range changes as it is affected by outliers*

D-S.1.1.2

42. The heights, rounded to the nearest foot, of the trees in a park are listed below.

23 13 8 52 26 42 48 52

What is the **median** of the tree heights?

- A. 33 feet *mean*
- B. 34 feet \*
- C. 39 feet *middle of unordered set*
- D. 44 feet *range*

D-S.1.1.2

43. Enrique and his classmates recorded the distances, in miles, they each traveled for spring break. Their data is shown in the box-and-whisker plot below.

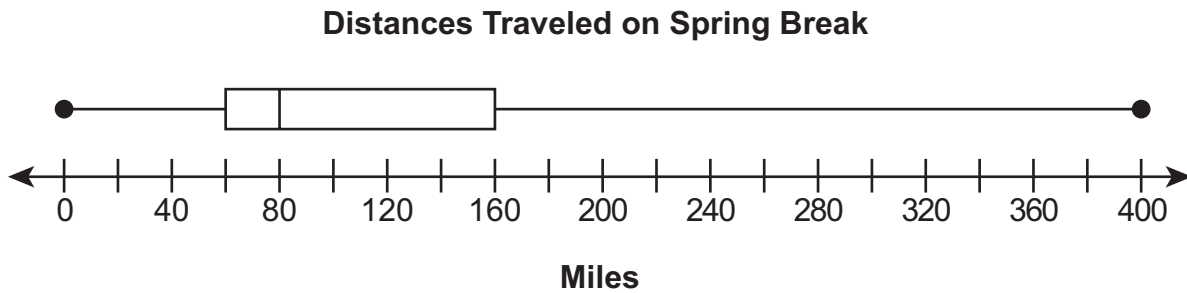

Which statement **must** be true?

- A. The median distance traveled is 80 miles.
- B. The median distance traveled is 200 miles.
- C. The mean distance traveled is 80 miles.
- D. The mean distance traveled is 200 miles.

\*

*this is the middle value on the scale*

*does not consider the skewness of the data*

*this is the middle value on the scale*

## D-S.1.1.3

44. The bar graph below shows how many questions various percentages of students in a class answered correctly on a recent 10-question quiz.

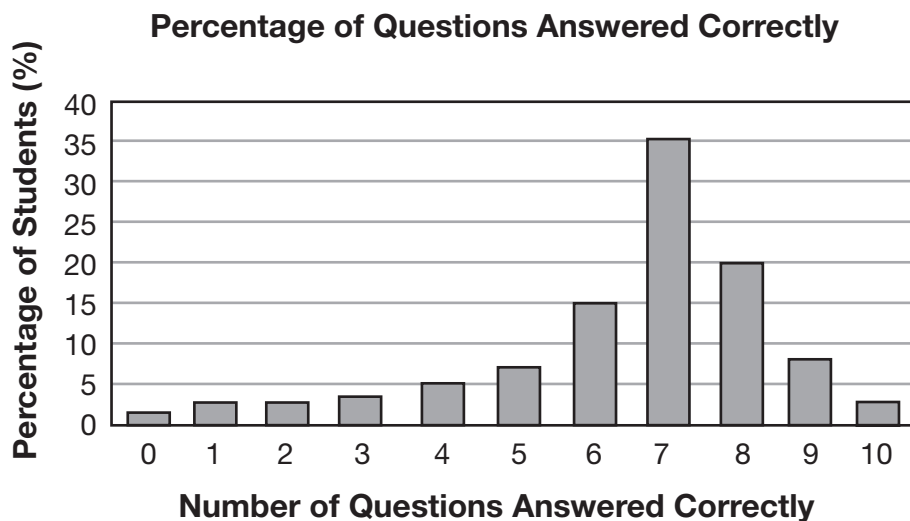

Which statement **best** describes the data displayed in the bar graph?

- A. Half the class answered from 0 to 5 of the 10 questions correctly.

*thinks since 5 is half of 10, it must represent half the population*

- B. Most of the students answered approximately 35% of the quiz questions correctly.

*misinterprets 35% relating to the highest bar*

- C. The number of quiz questions answered correctly is clustered around 7 out of 10.

\*

- D. The percentage of students increases as the number of questions answered correctly increases.

*ignores that the percentages start to decrease after 7*



## D-S.1.1.3

45. The histogram below represents the weights, rounded to the nearest pound, of several orders of dog food.

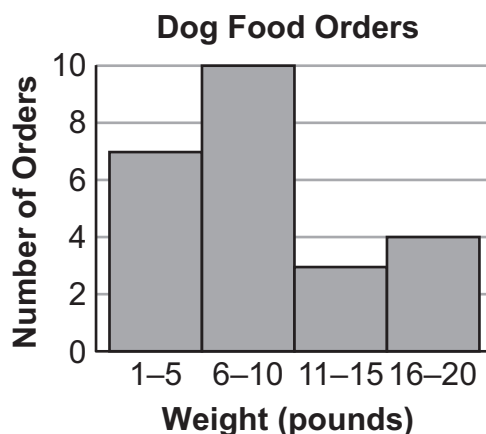

Which statement **best** describes the weights of the orders represented in the histogram?

- A. The orders cluster near 20 pounds.

*thinks a cluster occurs since last bar is taller than previous bar*

- B. The orders are symmetrical about 8 pounds.

*7 data points below and above 6-10 bin, so uses middle value between 6 and 10*

- C. There is a gap in the orders from 11 to 15 pounds.

*thinks a gap since orders decrease, then increase again*

- D. There is a peak in the orders from 6 to 10 pounds.

\*

FIRST OPEN-ENDED QUESTION

A-N.1.1



Question 46  
Page 1 of 3

?

Calculator

Line Guide

Search

Tablet

Pen

Cursor

Mr. Shepherd is building a rock wall. He estimates he will need  $7\frac{3}{4}$  tons of rock to complete the wall. His pickup truck can carry **at most**  $\frac{3}{4}$  ton of rock in each load.

Mr. Shepherd loads his pickup truck with  $\frac{3}{4}$  ton of rock for each load except the last one.

**A.** How many **full** loads of rock will Mr. Shepherd take with his pickup truck, and what fraction of a load of rock will he need to take on the last load? Show or explain all your work.

Next

EQ

EQ

fraction of the last load:

EQ

full loads:

0 / 1000







Review/End Test

Pause

Flag

Options

Question 46  
Page 2 of 3



---

Mr. Shepherd is building a rock wall. He estimates he will need  $7\frac{3}{4}$  tons of rock to complete the wall. His pickup truck can carry **at most**  $\frac{3}{4}$  ton of rock in each load.

For a second project, Mr. Shepherd uses the same pickup truck and fills it 5 times. He organizes the rocks into piles that are  $\frac{1}{2}$  ton each.

**B.** How many  $\frac{1}{2}$ -ton piles of rock does Mr. Shepherd have when he uses the 5 full loads of rock? Show or explain all your work.

0 / 1000

Review/End Test

Pause







Flag

Options

Back

Next

Question 46  
Page 3 of 3



---

Mr. Shepherd is building a rock wall. He estimates he will need  $7\frac{3}{4}$  tons of rock to complete the wall. His pickup truck can carry **at most**  $\frac{3}{4}$  ton of rock in each load.

For a third project, Mr. Shepherd needs  $x$  tons of rock, where  $x$  is a whole number greater than 1.

**C.** Explain how you know that it would take **at least**  $(x + 1)$  loads using Mr. Shepherd's pickup truck to get all the rock for this project.

0 / 1000

Review/End Test

Pause

Flag

Options

Back

**ITEM-SPECIFIC SCORING GUIDELINE**

**Question #46**

**Grade 6**

**Assessment Anchor this item will be reported under:**

M06.A-N.1—Apply and extend previous understandings of multiplication and division to divide fractions by fractions.

**Specific Anchor Descriptor addressed by this item:**

M06.A-N.1.1—Solve real-world and mathematical problems involving division of fractions.

**Scoring Guide:**

Score	In this item, the student –
4	Demonstrates a thorough understanding of how to apply and extend previous understandings of multiplication and division to divide fractions by fractions by correctly solving problems and clearly explaining procedures.
3	Demonstrates a general understanding of how to apply and extend previous understandings of multiplication and division to divide fractions by fractions by correctly solving problems and clearly explaining procedures with only minor errors or omissions.
2	Demonstrates a partial understanding of how to apply and extend previous understandings of multiplication and division to divide fractions by fractions by correctly performing a significant portion of the required task.
1	Demonstrates minimal understanding of patterns of how to apply and extend previous understandings of multiplication and division to divide fractions by fractions.
0	The response has no correct answer and insufficient evidence to demonstrate any understanding of the mathematical concepts and procedures as required by the task. Response may show only information copied from the question.
Non-Scorables	B – Blank R – Refusal K – Off task/topic F – Foreign language U – Illegible

**Top Scoring Student Response And Training Notes:**

Score	Description
4	Student earns 4 points.
3	Student earns 3.0 – 3.5 points.
2	Student earns 2.0 – 2.5 points.
1	Student earns 0.5 – 1.5 points. OR Student demonstrates minimal understanding of how to apply and extend previous understandings of multiplication and division to divide fractions by fractions.
0	Response is incorrect or contains some correct work that is irrelevant to the skill or concept being measured.

Question #46

Top Scoring Response:

Part A Answer	
What?	Why?
full loads: 10 fraction of a ton on last load: $\frac{1}{3}$	<p><b>Sample Work:</b></p> $7\frac{3}{4} = \frac{31}{4} \rightarrow \frac{31}{4} \div \frac{3}{4} = \frac{31}{4} \times \frac{4}{3} = \frac{31}{3} = 10\frac{1}{3}$ <p><b>OR</b></p> <p><b>Sample Explanation:</b></p> I divided $7\frac{3}{4}$ by $\frac{3}{4}$ to find out how many loads of rock he needs to get, and that's $10\frac{1}{3}$ , so there are 10 full loads, and then another $\frac{1}{3}$ load is still needed. <p><b>OR equivalent</b></p>

(2 score points)

$\frac{1}{2}$  point for each correct answer

1 point for correct and complete support answer

OR  $\frac{1}{2}$  point for correct but incomplete support

Part B Answer	
What?	Why?
$7\frac{1}{2}$ (piles)	<p><b>Sample Work:</b></p> $\frac{3}{4} \times 5 = 3\frac{3}{4} \rightarrow 3\frac{3}{4} \div \frac{1}{2} = 7\frac{1}{2}$ <p><b>OR</b></p> <p><b>Sample Explanation:</b></p> 5 full truckloads of rock is equal to $3\frac{3}{4}$ tons of rock. For each pile of rock to be $\frac{1}{2}$ ton means multiplying $3\frac{3}{4}$ and 2 which is $7\frac{1}{2}$ . <p><b>OR equivalent</b></p>

(1 score point)

$\frac{1}{2}$  point for correct answer

$\frac{1}{2}$  point for correct and complete support

Part C Answer	
What?	Why?
	<p><b>Sample Explanation:</b></p> His truck holds less than 1 ton. When dividing by a number smaller than 1, the answer is always bigger than the number you started with. <p><b>OR equivalent</b></p>

(1 score point)

1 point for complete explanation

OR  $\frac{1}{2}$  point for correct but incomplete explanation

FIRST OPEN-ENDED QUESTION RESPONSES

A-N.1.1 Response Score: 4



Question 46  
Page 1 of 3

Line Guide

Next

---

Mr. Shepherd is building a rock wall. He estimates he will need  $7\frac{3}{4}$  tons of rock to complete the wall. His pickup truck can carry at most  $\frac{3}{4}$  ton of rock in each load.

Mr. Shepherd loads his pickup truck with  $\frac{3}{4}$  ton of rock for each load except the last one.

A. How many **full** loads of rock will Mr. Shepherd take with his pickup truck, and what fraction of a load of rock will he need to take on the last load? Show or explain all your work.

$$7\frac{3}{4} = \frac{31}{4}$$

$$\frac{31}{4} \div \frac{3}{4} = \frac{31}{4} \times \frac{4}{3} = \frac{31}{3}$$

$$\frac{31}{3} = 10\frac{1}{3} \text{ in all}$$

full loads:

fraction of the last load:

The student has given two correct answers.  
The student has shown complete support.

Review/End Test

Pause

Flag

Options

Question 46  
Page 2 of 3



Mr. Shepherd is building a rock wall. He estimates he will need  $7\frac{3}{4}$  tons of rock to complete the wall. His pickup truck can carry at most  $\frac{3}{4}$  ton of rock in each load.

For a second project, Mr. Shepherd uses the same pickup truck and fills it 5 times. He organizes the rocks into piles that are  $\frac{1}{2}$  ton each.

**B.** How many  $\frac{1}{2}$ -ton piles of rock does Mr. Shepherd have when he uses the 5 full loads of rock? Show or explain all your work.

Eq1

$\frac{3}{4}$  ton = full load

$\frac{3}{4} \times \frac{5}{1} = \frac{15}{4} = 3\frac{3}{4}$  tons is 5 full pickups

Since each pile is  $\frac{1}{2}$  ton, multiply  $3\frac{3}{4} \times 2$  to get  $\frac{15}{4} \times 2 = \frac{30}{4}$  and that is  $7\frac{1}{2}$  piles.

The student has given a correct answer.  
The student has shown complete support.

123 / 1000

Review/End Test

Pause

Flag

Options

Back

Next



Question 46  
Page 3 of 3

Mr. Shepherd is building a rock wall. He estimates he will need  $7\frac{3}{4}$  tons of rock to complete the wall. His pickup truck can carry **at most**  $\frac{3}{4}$  ton of rock in each load.

For a third project, Mr. Shepherd needs  $x$  tons of rock, where  $x$  is a whole number greater than 1.

C. Explain how you know that it would take **at least**  $(x + 1)$  loads using Mr. Shepherd's pickup truck to get all the rock for this project.

?

EQ

$x$  is bigger than 1 and his truck only holds  $\frac{3}{4}$  ton which is less than 1 so he will need at least 2 loads to get enough rocks for his project.

Back

The student has given a complete explanation.

139 / 1000

Review/End Test

Pause

Flag

Options

A-N.1.1 Response Score: 3



Question 46  
Page 1 of 3

Mr. Shepherd is building a rock wall. He estimates he will need  $7\frac{3}{4}$  tons of rock to complete the wall. His pickup truck can carry **at most**  $\frac{3}{4}$  ton of rock in each load.

Mr. Shepherd loads his pickup truck with  $\frac{3}{4}$  ton of rock for each load except the last one.

**A.** How many **full** loads of rock will Mr. Shepherd take with his pickup truck, and what fraction of a load of rock will he need to take on the last load? Show or explain all your work.

EOI

$\frac{3}{4}$	$1\frac{1}{2}$	$2\frac{1}{4}$	$3$	$3\frac{3}{4}$	$4\frac{1}{2}$	$5\frac{1}{4}$	$6$	$6\frac{3}{4}$	$7\frac{1}{2}$	$7\frac{3}{4}$
1	2	3	4	5	6	7	8	9	10	

full loads:

fraction of the last load:

65 / 1000

The student has given one correct answer.  
The student has shown correct but incomplete support.

Review/End Test

Pause

Flag

Options

Next

Question 46  
Page 2 of 3



Mr. Shepherd is building a rock wall. He estimates he will need  $7\frac{3}{4}$  tons of rock to complete the wall. His pickup truck can carry **at most**  $\frac{3}{4}$  ton of rock in each load.

For a second project, Mr. Shepherd uses the same pickup truck and fills it 5 times. He organizes the rocks into piles that are  $\frac{1}{2}$  ton each.

**B.** How many  $\frac{1}{2}$ -ton piles of rock does Mr. Shepherd have when he uses the 5 full loads of rock? Show or explain all your work.

EO

$$\frac{3}{4} \quad 1\frac{1}{2} \quad 2\frac{1}{4} \quad 3 \quad 3\frac{3}{4}$$

$$1 \quad 2 \quad 3 \quad 4 \quad 5 \text{ trucks full}$$





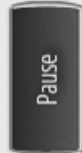
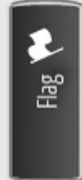
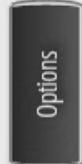

$$3\frac{3}{4} \div \frac{1}{2} = 7\frac{1}{2}$$

The student has given a correct answer.  
The student has shown complete support.

56 / 1000



Question 46  
Page 3 of 3



---

Mr. Shepherd is building a rock wall. He estimates he will need  $7\frac{3}{4}$  tons of rock to complete the wall. His pickup truck can carry **at most**  $\frac{3}{4}$  ton of rock in each load.

For a third project, Mr. Shepherd needs  $x$  tons of rock, where  $x$  is a whole number greater than 1.

**C.** Explain how you know that it would take **at least**  $(x + 1)$  loads using Mr. Shepherd's pickup truck to get all the rock for this project.

Mr. Shepherd's truck doesn't hold 1 ton, it only holds  $\frac{3}{4}$  ton so he is going to have to fill it more than 1 time to get more than 1 ton no matter what.

The student has given a complete explanation.

149 / 1000

Review/End Test

Pause

Flag

Options

Back

A-N.1.1 Response Score: 2



Question 46  
Page 1 of 3

Mr. Shepherd is building a rock wall. He estimates he will need  $7\frac{3}{4}$  tons of rock to complete the wall. His pickup truck can carry **at most**  $\frac{3}{4}$  ton of rock in each load.

Mr. Shepherd loads his pickup truck with  $\frac{3}{4}$  ton of rock for each load except the last one.

**A.** How many **full** loads of rock will Mr. Shepherd take with his pickup truck, and what fraction of a load of rock will he need to take on the last load? Show or explain all your work.

EQ

$$7\frac{3}{4} = \frac{31}{4}$$

$$\frac{31}{4} \text{ divided by } \frac{3}{4} \text{ is } 10\frac{1}{3}$$

26 / 1000

full loads:

fraction of the last load:

EQ

The student has given two correct answers.  
The student has shown complete support.

Review/End Test

Pause

Flag

Options

Next

Question 46  
Page 2 of 3



Mr. Shepherd is building a rock wall. He estimates he will need  $7\frac{3}{4}$  tons of rock to complete the wall. His pickup truck can carry **at most**  $\frac{3}{4}$  ton of rock in each load.

For a second project, Mr. Shepherd uses the same pickup truck and fills it 5 times. He organizes the rocks into piles that are  $\frac{1}{2}$  ton each.

**B.** How many  $\frac{1}{2}$ -ton piles of rock does Mr. Shepherd have when he uses the 5 full loads of rock? Show or explain all your work.

EOI

$$\frac{1}{2} \times 5 = \frac{5}{2}$$







He has  $2\frac{1}{2}$  piles of rock.

The student has given an incorrect answer.  
The student has shown incorrect support.

30 / 1000



Question 46  
Page 3 of 3



---

Mr. Shepherd is building a rock wall. He estimates he will need  $7\frac{3}{4}$  tons of rock to complete the wall. His pickup truck can carry **at most**  $\frac{3}{4}$  ton of rock in each load.

For a third project, Mr. Shepherd needs  $x$  tons of rock, where  $x$  is a whole number greater than 1.





**C.** Explain how you know that it would take **at least**  $(x + 1)$  loads using Mr. Shepherd's pickup truck to get all the rock for this project.

Eq

$x$  is bigger than 1 so it is 2  
 $(2 + 1)$

The student has given an incorrect explanation.

39 / 1000



A-N.1.1 Response Score: 1



Question 46  
Page 1 of 3

Item ID

?

Line Guide

Mr. Shepherd is building a rock wall. He estimates he will need  $7\frac{3}{4}$  tons of rock to complete the wall. His pickup truck can carry at most  $\frac{3}{4}$  ton of rock in each load.

Mr. Shepherd loads his pickup truck with  $\frac{3}{4}$  ton of rock for each load except the last one.

**A.** How many **full** loads of rock will Mr. Shepherd take with his pickup truck, and what fraction of a load of rock will he need to take on the last load? Show or explain all your work.

EO

There are 10 loads beacuse I kept adding  $\frac{3}{4} + \frac{3}{4} + \frac{3}{4}$  and kept going until I got to  $7\frac{3}{4}$  and then counted how many I had and it was 10.

EO

full loads: 10

EO

fraction of the last load:  $\frac{3}{4}$

The student has given one correct answer.  
The student has shown correct but incomplete support.

Review/End Test

Pause

Flag

Options

Next



Question 46  
Page 2 of 3



Mr. Shepherd is building a rock wall. He estimates he will need  $7\frac{3}{4}$  tons of rock to complete the wall. His pickup truck can carry **at most**  $\frac{3}{4}$  ton of rock in each load.

For a second project, Mr. Shepherd uses the same pickup truck and fills it 5 times. He organizes the rocks into piles that are  $\frac{1}{2}$  ton each.

**B.** How many  $\frac{1}{2}$ -ton piles of rock does Mr. Shepherd have when he uses the 5 full loads of rock? Show or explain all your work.

EO

$$\frac{1}{2} \times 5 = 2 \times 5 = 10$$





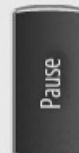
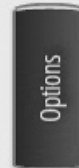

10 / 1000

The student has given an incorrect answer.  
The student has shown incorrect support.



Question 46  
Page 3 of 3





Mr. Shepherd is building a rock wall. He estimates he will need  $7\frac{3}{4}$  tons of rock to complete the wall. His pickup truck can carry **at most**  $\frac{3}{4}$  ton of rock in each load.

For a third project, Mr. Shepherd needs  $x$  tons of rock, where  $x$  is a whole number greater than 1.

**C.** Explain how you know that it would take **at least**  $(x + 1)$  loads using Mr. Shepherd's pickup truck to get all the rock for this project.

$x > 1$

The student has given an incorrect explanation.

5 / 1000

Review/End Test

Pause

Flag

Options

A-N.1.1 Response Score: 0



Question 46  
Page 1 of 3

---

Mr. Shepherd is building a rock wall. He estimates he will need  $7\frac{3}{4}$  tons of rock to complete the wall. His pickup truck can carry **at most**  $\frac{3}{4}$  ton of rock in each load.

Mr. Shepherd loads his pickup truck with  $\frac{3}{4}$  ton of rock for each load except the last one.

**A.** How many **full** loads of rock will Mr. Shepherd take with his pickup truck, and what fraction of a load of rock will he need to take on the last load? Show or explain all your work.

He needs  $7\frac{3}{4}$  tons and  $\frac{3}{4}$  ton

full loads:

fraction of the last load:

The student has given no correct answers.  
The student has shown incorrect support.





Review/End Test

Pause

Flag

Options

Question 46  
Page 2 of 3





Mr. Shepherd is building a rock wall. He estimates he will need  $7\frac{3}{4}$  tons of rock to complete the wall. His pickup truck can carry **at most**  $\frac{3}{4}$  ton of rock in each load.

For a second project, Mr. Shepherd uses the same pickup truck and fills it 5 times. He organizes the rocks into piles that are  $\frac{1}{2}$  ton each.

**B.** How many  $\frac{1}{2}$ -ton piles of rock does Mr. Shepherd have when he uses the 5 full loads of rock? Show or explain all your work.

He will fill his truck 5 times with rock piles that are  $\frac{1}{2}$  ton.



Review/End Test

Pause







Flag

Options

The student has given an incorrect answer.  
The student has shown incorrect support.

61 / 1000

Question 46  
Page 3 of 3



---

Mr. Shepherd is building a rock wall. He estimates he will need  $7\frac{3}{4}$  tons of rock to complete the wall. His pickup truck can carry **at most**  $\frac{3}{4}$  ton of rock in each load.

For a third project, Mr. Shepherd needs  $x$  tons of rock, where  $x$  is a whole number greater than 1.





**C.** Explain how you know that it would take **at least**  $(x + 1)$  loads using Mr. Shepherd's pickup truck to get all the rock for this project.

EQ

Mr. Shepherd can fill his truck one more time than he needs.

The student has given an incorrect explanation.

60 / 1000



**SECOND OPEN-ENDED QUESTION**

A-R.1.1.5

A-R.1.1.1

47. Students from four classes are in a school play.

There are 28 students in Mr. Flynn's class. The ratio of his students who are in the play to those who are **not** in the play is 2:5.

**A.** How many of Mr. Flynn's students are in the play?

Mrs. Cho has 24 students in her class. Some of her students are also in the play.

**B.** Explain why it is **not** possible for exactly 24% of the students in Mrs. Cho's class to be in the play.

**Go to the next page to finish question 47.**

47. **Continued.** Please refer to the previous page for task explanation.

The rest of the students in the play are from Mr. Logan's class and Ms. Gardner's class.

- Mr. Logan has 23 students in his class, and 7 of them are in the play.
  - There are 4 more students from Ms. Gardner's class than from Mrs. Cho's class in the play.
  - The number of students in the play from Mr. Logan's class is greater than the number from Mrs. Cho's class and fewer than the number from Ms. Gardner's class.
  - In all, 30% of the students in these three classes are in the play.
- C. Show or explain why there must be exactly 23 students in Ms. Gardner's class. As part of the explanation, determine how many students from Ms. Gardner's class are in the play.

**ITEM-SPECIFIC SCORING GUIDELINE**

**Question #47**

**Grade 6**

**Assessment Anchor this item will be reported under:**

M06.A-R.1— Understand ratio concepts and use ratio reasoning to solve problems.

**Specific Anchor Descriptor addressed by this item:**

M06.A-R.1.1—Represent and/or solve real-world and mathematical problems using rates, ratios, and/or percents.

**Scoring Guide:**

Score	In this item, the student –
4	Demonstrates a thorough understanding of ratio concepts and use ratio reasoning to solve problems by correctly solving problems and clearly explaining procedures.
3	Demonstrates a general understanding of ratio concepts and use ratio reasoning to solve problems by correctly solving problems and clearly explaining procedures with only minor errors or omissions.
2	Demonstrates a partial understanding of ratio concepts and use ratio reasoning to solve problems by correctly performing a significant portion of the required task.
1	Demonstrates minimal understanding of ratio concepts and use ratio reasoning to solve problems.
0	The response has no correct answer and insufficient evidence to demonstrate any understanding of the mathematical concepts and procedures as required by the task. Response may show only information copied from the question.
Non-Scorables	B – Blank R – Refusal K – Off task/topic F – Foreign language U – Illegible

**Top Scoring Student Response And Training Notes:**

Score	Description
4	Student earns 4 points.
3	Student earns 3.0 – 3.5 points.
2	Student earns 2.0 – 2.5 points.
1	Student earns 0.5 – 1.5 points. OR Student demonstrates minimal understanding of how to apply and extend previous understandings of numbers to the system of rational numbers.
0	Response is incorrect or contains some correct work that is irrelevant to the skill or concept being measured.



**Question #47**

**Top Scoring Response:**

Part A Answer	
What?	Why?
8 (students)	

**(1 score point)**

1 point for correct answer

Part B Answer	
What?	Why?
	<b>Sample Explanation:</b> 24% of 24 is the same as $0.24 \times 24 = 5.76$ and you can't have part of a student in the play, it has to be a whole number

**(1 score point)**

1 point for correct and complete explanation

OR ½ point for correct but incomplete explanation

Part C Answer													
What?	Why?												
9 (students)	<p><b>Sample Work:</b></p> <table border="1"> <thead> <tr> <th>Class</th> <th>Total Students</th> <th>Students in the Play</th> </tr> </thead> <tbody> <tr> <td>Mr. Logan</td> <td>23</td> <td>7</td> </tr> <tr> <td>Ms. Gardner</td> <td>?</td> <td><math>c + 4</math></td> </tr> <tr> <td>Mrs. Cho</td> <td>24</td> <td><math>c</math></td> </tr> </tbody> </table> <p> <math>c &lt; 7 &lt; c + 4 \rightarrow c = 4, 5, 6</math> and <math>c + 4 = 8, 9, 10</math>  <math>7 + 4 + 8 = 19 \rightarrow 19 \div 0.30 = 63.333... \times</math>  <math>7 + 5 + 9 = 21 \rightarrow 21 \div 0.30 = 70 \checkmark</math>  <math>7 + 6 + 10 = 23 \rightarrow 23 \div 0.30 = 76.666... \times</math>                      So, <math>c = 5</math> and <math>c + 4 = 9</math>  <math>23 + ? + 24 = 70 \rightarrow ? + 47 = 70 \rightarrow ? = 23</math> </p> <p><b>OR</b></p> <p><b>Sample Explanation:</b> I know that Mr. Logan's class has 23 students and Mrs. Cho's class has 24 students. There are 7 students from Mr. Logan's class in the play and that is more students than in Mrs. Cho's class and fewer than in Ms. Gardner's class in the play. The difference between the numbers of students in those two classes is 4. That means the possible number of students in those two classes are 4 and 8, 5 and 9, and 6 and 10. Of those possibilities, only the one with 5 and 9 can be added to 7 with the sum of 21 to be 30% of a whole number. 21 is 30% of 70. So <math>70 - 23 - 24 = 23</math>, which is the number of students in Ms. Gardner's class, and 9 of them are in the play.</p> <p><b>OR equivalent</b></p>	Class	Total Students	Students in the Play	Mr. Logan	23	7	Ms. Gardner	?	$c + 4$	Mrs. Cho	24	$c$
Class	Total Students	Students in the Play											
Mr. Logan	23	7											
Ms. Gardner	?	$c + 4$											
Mrs. Cho	24	$c$											

**(2 score points)**

1 point for correct answer

1 point for correct and complete support

OR ½ point for correct but incomplete explanation

**SECOND OPEN-ENDED QUESTION RESPONSES**

A-R.1.1.5

A-R.1.1.1 Response Score: 4

47. Students from four classes are in a school play.

There are 28 students in Mr. Flynn's class. The ratio of his students who are in the play to those who are **not** in the play is 2:5.

- A. How many of Mr. Flynn's students are in the play?

8

The student has given a correct answer.

Mrs. Cho has 24 students in her class. Some of her students are also in the play.

- B. Explain why it is **not** possible for exactly 24% of the students in Mrs. Cho's class to be in the play.

Because 24% of 24 is not a whole number it is 5.76 and you can't have part of a student.

The student has given a complete explanation.

Go to the next page to finish question 47.

47. **Continued.** Please refer to the previous page for task explanation.

The rest of the students in the play are from Mr. Logan's class and Ms. Gardner's class.

- Mr. Logan has 23 students in his class, and 7 of them are in the play.
- There are 4 more students from Ms. Gardner's class than from Mrs. Cho's class in the play.
- The number of students in the play from Mr. Logan's class is greater than the number from Mrs. Cho's class and fewer than the number from Ms. Gardner's class.
- In all, 30% of the students in these three classes are in the play.

C. Show or explain why there must be exactly 23 students in Ms. Gardner's class. As part of the explanation, determine how many students from Ms. Gardner's class are in the play.

Mrs. Cho has less than 7 in the play and Mrs. Gardner has the amount of Mrs. Cho plus 4 more. So that is 4, 5, or 6 for Mrs. Cho and  $4+4=8$  or  $5+4=9$  or  $6+4=10$  for Mrs. Gardner. Now I need to try adding these numbers to what Mr. Logan has, 7.

L	C	G	
7	4	8	= 19
7	5	9	= 21*
7	6	10	= 23

One of these numbers should be 30% of the total students in the play.  $19 \div .30 = 63.\overline{33}$   
 $21 \div .30 = 70$ .  $23 \div .30 = 76.\overline{66}$ . So if there are 70 students in all we know Mr. Logan has 23 + Mrs. Cho has 24, then Mrs. Gardner has the rest which is 23 and 9 of them are in the play.

The student has given a correct answer.  
 The student has shown complete support.

A-R.1.1.5

A-R.1.1.1 Response Score: 3

47. Students from four classes are in a school play.

There are 28 students in Mr. Flynn’s class. The ratio of his students who are in the play to those who are **not** in the play is 2:5.

A. How many of Mr. Flynn’s students are in the play?

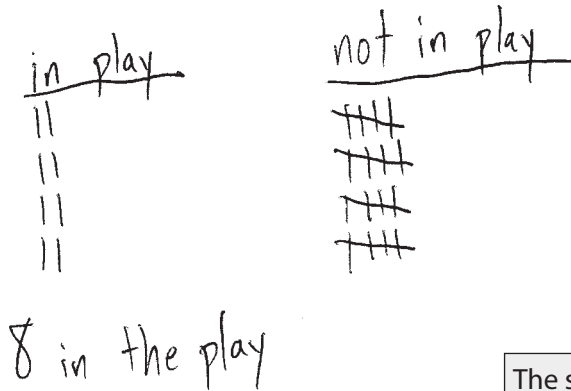

The student has given a correct answer.

Mrs. Cho has 24 students in her class. Some of her students are also in the play.

B. Explain why it is **not** possible for exactly 24% of the students in Mrs. Cho’s class to be in the play.

$$\frac{24}{100} = \frac{x}{24}$$

$$100x = 576$$

$$x = 5.76$$

But there can't be a person who isn't whole in Mrs. Cho's class

The student has given a complete explanation.

Go to the next page to finish question 47.

47. **Continued.** Please refer to the previous page for task explanation.

The rest of the students in the play are from Mr. Logan's class and Ms. Gardner's class.

- Mr. Logan has 23 students in his class, and 7 of them are in the play.
- There are 4 more students from Ms. Gardner's class than from Mrs. Cho's class in the play.
- The number of students in the play from Mr. Logan's class is greater than the number from Mrs. Cho's class and fewer than the number from Ms. Gardner's class.
- In all, 30% of the students in these three classes are in the play.

Mrs. Cho - 24 students

C. Show or explain why there must be exactly 23 students in Ms. Gardner's class. As part of the explanation, determine how many students from Ms. Gardner's class are in the play.

Facts

$$23 + 23 + 24 = 70 \text{ students all together}$$

Mr. Logan - 7 in play more than Mrs. Cho  
less than Mrs. Gardner

Mrs. Gardner - 4 more than Mrs. Cho

Mrs. Cho - less than Mr. Logan ( $< 7$ )

$$30\% \text{ of } 70 = 21$$

$$7 + ? + ? = 21$$

5   9

I think it is  
9 for Mrs. Gardner  
in the play

The student has given a correct answer.  
The student has shown correct but incomplete support.

A-R.1.1.5

A-R.1.1.1 Response Score: 2

47. Students from four classes are in a school play.

There are 28 students in Mr. Flynn's class. The ratio of his students who are in the play to those who are **not** in the play is 2:5.

A. How many of Mr. Flynn's students are in the play?

Eight

The student has given a correct answer.

Mrs. Cho has 24 students in her class. Some of her students are also in the play.

B. Explain why it is **not** possible for exactly 24% of the students in Mrs. Cho's class to be in the play.

Mrs. Cho can't have only part of a person in the play and 24% of 24 is not a whole number

The student has given a complete explanation.

Go to the next page to finish question 47.

47. **Continued.** Please refer to the previous page for task explanation.

The rest of the students in the play are from Mr. Logan's class and Ms. Gardner's class.

- Mr. Logan has 23 students in his class, and 7 of them are in the play.
  - There are 4 more students from Ms. Gardner's class than from Mrs. Cho's class in the play.
  - The number of students in the play from Mr. Logan's class is greater than the number from Mrs. Cho's class and fewer than the number from Ms. Gardner's class.
  - In all, 30% of the students in these three classes are in the play.
- C. Show or explain why there must be exactly 23 students in Ms. Gardner's class. As part of the explanation, determine how many students from Ms. Gardner's class are in the play.

Because it says Mr. Logan has 23  
and Mrs. Cho has 24 and Ms. Gardner  
has 23. I think that she has 11  
students in the play.  $7+4=11$ .

The student has given an incorrect answer.  
The student has shown incorrect support.

A-R.1.1.5

A-R.1.1.1 Response Score: 1

47. Students from four classes are in a school play.

There are 28 students in Mr. Flynn's class. The ratio of his students who are in the play to those who are **not** in the play is 2:5.

- A. How many of Mr. Flynn's students are in the play?

$$\begin{array}{r} 2 : 5 \\ \times 4 \quad 4^x \\ \hline 8 : 20 \end{array}$$

8

The student has given a correct answer.

Mrs. Cho has 24 students in her class. Some of her students are also in the play.

- B. Explain why it is **not** possible for exactly 24% of the students in Mrs. Cho's class to be in the play.

That would mean that they are all in the play not just some of them.

The student has given an incorrect explanation.

Go to the next page to finish question 47.



47. **Continued.** Please refer to the previous page for task explanation.

The rest of the students in the play are from Mr. Logan's class and Ms. Gardner's class.

- Mr. Logan has 23 students in his class, and 7 of them are in the play.
  - There are 4 more students from Ms. Gardner's class than from Mrs. Cho's class in the play.
  - The number of students in the play from Mr. Logan's class is greater than the number from Mrs. Cho's class and fewer than the number from Ms. Gardner's class.
  - In all, 30% of the students in these three classes are in the play.
- C. Show or explain why there must be exactly 23 students in Ms. Gardner's class. As part of the explanation, determine how many students from Ms. Gardner's class are in the play.

Mr. Logan has 7 in the play and that is more than Mrs. Cho and less than Mrs. Gardner so it could be 6 for Mrs. Cho and 8 for Mrs. Gardner.

$23 - 8 = 15$  so 8 or 15 students from Mrs. Gardner's class were in the play.

The student has given an incorrect answer.  
The student has shown incorrect support.

A-R.1.1.5

A-R.1.1.1 Response Score: 0

47. Students from four classes are in a school play.

There are 28 students in Mr. Flynn's class. The ratio of his students who are in the play to those who are **not** in the play is 2:5.

A. How many of Mr. Flynn's students are in the play?

2

The student has given an incorrect answer.

Mrs. Cho has 24 students in her class. Some of her students are also in the play.

B. Explain why it is **not** possible for exactly 24% of the students in Mrs. Cho's class to be in the play.

If exactly 24% of them were in the play then some would not have a very big part.

The student has given an incorrect explanation.

Go to the next page to finish question 47.

47. **Continued.** Please refer to the previous page for task explanation.

The rest of the students in the play are from Mr. Logan's class and Ms. Gardner's class.

- Mr. Logan has 23 students in his class, and 7 of them are in the play.
  - There are 4 more students from Ms. Gardner's class than from Mrs. Cho's class in the play.
  - The number of students in the play from Mr. Logan's class is greater than the number from Mrs. Cho's class and fewer than the number from Ms. Gardner's class.
  - In all, 30% of the students in these three classes are in the play.
- C. Show or explain why there must be exactly 23 students in Ms. Gardner's class. As part of the explanation, determine how many students from Ms. Gardner's class are in the play.

Logan play play  
 $23 - 7 + 4 = 20$

23 for Mrs. Gardner

The student has given an incorrect answer.  
The student has shown incorrect support.

THIRD OPEN-ENDED QUESTION

B-E.3



Question 48  
Page 1 of 2

**A.** Write an equation that describes the relationship between the number of pounds of tomatoes sold ( $x$ ) and the total price ( $y$ ), in dollars.

EQ

The farmer also sells green beans at the vegetable stand. The equation below can be used to find the total price ( $p$ ) in dollars of  $g$  pounds of green beans.

$$p = 1.75g$$

**B.** What is the total price, in dollars, of 17 pounds of green beans? Explain what the 1.75 represents in the context of the situation.

EQ

Next

**Tomatoes**

Number of Pounds Sold	Total Price (\$)
2	5.00
5	12.50
9	22.50

**A.** Write an equation that describes the relationship between the number of pounds of tomatoes sold ( $x$ ) and the total price ( $y$ ), in dollars.

EQ

The farmer also sells green beans at the vegetable stand. The equation below can be used to find the total price ( $p$ ) in dollars of  $g$  pounds of green beans.

$$p = 1.75g$$

**B.** What is the total price, in dollars, of 17 pounds of green beans? Explain what the 1.75 represents in the context of the situation.

EQ

0 / 1000

Review/End Test

Pause

Flag

Options

Next

Question 48

Page 2 of 2



A farmer sells tomatoes at a vegetable stand. Each pound of tomatoes sells for the same amount. The table below shows the total prices for different numbers of pounds of tomatoes sold.

Tomatoes

Number of Pounds Sold	Total Price (\$)
2	5.00
5	12.50
9	22.50

The farmer decides to increase the price per pound of the tomatoes. A graph is created to represent both the original equation from **part A** and a new equation based on the increased price per pound of the tomatoes.

C. Explain why the graphs representing the equations will share one point even though the prices per pound are different.

0 / 1000



**ITEM-SPECIFIC SCORING GUIDELINE**

**Question #48**

**Grade 6**

**Assessment Anchor this item will be reported under:**

M06.B-E.3—Represent and analyze quantitative relationships between dependent and independent variables.

**Specific Anchor Descriptor addressed by this item:**

M06.B-E.3.1—Use variables to represent two quantities in a real-world problem that change in relationship to one another.

**Scoring Guide:**

Score	In this item, the student –
4	Demonstrates a thorough understanding of how to represent and analyze quantitative relationships between dependent and independent variables by correctly solving problems and clearly explaining procedures.
3	Demonstrates a general understanding of how to represent and analyze quantitative relationships between dependent and independent variables by correctly solving problems and clearly explaining procedures with only minor errors or omissions.
2	Demonstrates a partial understanding of how to represent and analyze quantitative relationships between dependent and independent variables by correctly performing a significant portion of the required task.
1	Demonstrates minimal understanding of how to represent and analyze quantitative relationships between dependent and independent variables.
0	The response has no correct answer and insufficient evidence to demonstrate any understanding of the mathematical concepts and procedures as required by the task. Response may show only information copied from the question.
Non-Scorables	B – Blank R – Refusal K – Off task/topic F – Foreign language U – Illegible

**Top Scoring Student Response And Training Notes:**

Score	Description
4	Student earns 4 points.
3	Student earns 3.0 – 3.5 points.
2	Student earns 2.0 – 2.5 points.
1	Student earns 0.5 – 1.5 points. OR Student demonstrates minimal understanding of how to represent and analyze quantitative relationships between dependent and independent variables.
0	Response is incorrect or contains some correct work that is irrelevant to the skill or concept being measured.

**Question #48**

**Top Scoring Response:**

Part A Answer	
What?	Why?
$y = 2.50x$ <b>OR equivalent</b>	

**(1 score point)**

1 point for correct answer

Part B Answer	
What?	Why?
(\$) 29.75	<b>Sample Explanations:</b> The 1.75 represents the price per pound of the green beans <b>OR</b> The price of the green beans is \$1.75 per pound. <b>OR equivalent</b>

**(2 score points)**

1 point for correct answer

1 point for complete explanation

OR ½ point for correct but incomplete explanation

Part C Answer	
What?	Why?
	<b>Sample Explanation:</b> Even though the price per pound increases, both graphs have to start at (0, 0) since selling 0 pounds would have a total price of \$0.00 for either price per pound. So the graphs representing the equations will share the point (0, 0). After that point, the graphs would be different.

**(1 score point)**

1 point for complete explanation

OR ½ point for correct but incomplete explanation

THIRD OPEN-ENDED QUESTION RESPONSES

B-E.3 Response Score: 4



Question 48  
Page 1 of 2

A farmer sells tomatoes at a vegetable stand. Each pound of tomatoes sells for the same amount. The table below shows the total prices for different numbers of pounds of tomatoes sold.

Tomatoes	
Number of Pounds Sold	Total Price (\$)
2	5.00
5	12.50
9	22.50

A. Write an equation that describes the relationship between the number of pounds of tomatoes sold ( $x$ ) and the total price ( $y$ ), in dollars.

Eq

$$y = 2.5x$$

The student has given a correct answer.

The farmer also sells green beans at the vegetable stand. The equation below can be used to find the total price ( $p$ ) in dollars of  $g$  pounds of green beans.

$$p = 1.75g$$

B. What is the total price, in dollars, of 17 pounds of green beans? Explain what the 1.75 represents in the context of the situation.

Eq

$$p = 1.75 \times 17 = 29.75$$

The 1.75 is "price per pound" for green beans.

The student has given a correct answer.  
The student has given a complete explanation.

61 / 1000

Next

Options

Flag

Pause

Review/End Test



Question 48  
Page 2 of 2



A farmer sells tomatoes at a vegetable stand. Each pound of tomatoes sells for the same amount. The table below shows the total prices for different numbers of pounds of tomatoes sold.

Tomatoes	
Number of Pounds Sold	Total Price (\$)
2	5.00
5	12.50
9	22.50

The farmer decides to increase the price per pound of the tomatoes. A graph is created to represent both the original equation from **part A** and a new equation based on the increased price per pound of the tomatoes.

C. Explain why the graphs representing the equations will share one point even though the prices per pound are different.

So if the price per pound for tomatoes was to increase from \$2.50 to \$3.00, then, the cost of no pounds, or zero pounds would be  $0 \times 2.50$  which equals 0 and  $0 \times 3.00$  which also equals 0. this would be the place where the two equations would share one point at the origin (0, 0).

The student has given a complete explanation.

274 / 1000



B-E.3 Response Score: 3



Question 48  
Page 1 of 2

A farmer sells tomatoes at a vegetable stand. Each pound of tomatoes sells for the same amount. The table below shows the total prices for different numbers of pounds of tomatoes sold.

Tomatoes	
Number of Pounds Sold	Total Price (\$)
2	5.00
5	12.50
9	22.50

Options

Flag

Pause

Review/End Test

A. Write an equation that describes the relationship between the number of pounds of tomatoes sold ( $x$ ) and the total price ( $y$ ), in dollars.

Eq

$y = \frac{5.00}{2}x$

The student has given a correct answer.

The farmer also sells green beans at the vegetable stand. The equation below can be used to find the total price ( $p$ ) in dollars of  $g$  pounds of green beans.

$$p = 1.75g$$

B. What is the total price, in dollars, of 17 pounds of green beans? Explain what the 1.75 represents in the context of the situation.

Eq

$p = 29.75$

1.75 represents the price of 1 pound of green beans.

The student has given a correct answer.

The student has given a complete explanation.

62 / 1000

Question 48  
Page 2 of 2



A farmer sells tomatoes at a vegetable stand. Each pound of tomatoes sells for the same amount. The table below shows the total prices for different numbers of pounds of tomatoes sold.

Tomatoes	
Number of Pounds Sold	Total Price (\$)
2	5.00
5	12.50
9	22.50

The farmer decides to increase the price per pound of the tomatoes. A graph is created to represent both the original equation from **part A** and a new equation based on the increased price per pound of the tomatoes.

C. Explain why the graphs representing the equations will share one point even though the prices per pound are different.

Because they will both start at the same place.

The student has given an incorrect explanation.

47 / 1000

Review/End Test

Pause

Flag

Options

Back

B-E.3 Response Score: 2



Question 48  
Page 1 of 2

**Next**

**A.** A farmer sells tomatoes at a vegetable stand. Each pound of tomatoes sells for the same amount. The table below shows the total prices for different numbers of pounds of tomatoes sold.

Tomatoes	
Number of Pounds Sold	Total Price (\$)
2	5.00
5	12.50
9	22.50

**A.** Write an equation that describes the relationship between the number of pounds of tomatoes sold ( $x$ ) and the total price ( $y$ ), in dollars.

Eq

$y=2.50(x)$

The student has given a correct answer.

The farmer also sells green beans at the vegetable stand. The equation below can be used to find the total price ( $p$ ) in dollars of  $g$  pounds of green beans.

$$p = 1.75g$$

**B.** What is the total price, in dollars, of 17 pounds of green beans? Explain what the 1.75 represents in the context of the situation.

Eq

$p=1.75g=1.75(17)=29.75$   
It's what the 17 is multiplied by.

The student has given a correct answer.  
The student has given an incorrect explanation.

57 / 1000

**Review/End Test**

**Pause**

**Flag**

**Options**

**Next**

Question 48  
Page 2 of 2



A farmer sells tomatoes at a vegetable stand. Each pound of tomatoes sells for the same amount. The table below shows the total prices for different numbers of pounds of tomatoes sold.

Tomatoes	
Number of Pounds Sold	Total Price (\$)
2	5.00
5	12.50
9	22.50

The farmer decides to increase the price per pound of the tomatoes. A graph is created to represent both the original equation from **part A** and a new equation based on the increased price per pound of the tomatoes.

C. Explain why the graphs representing the equations will share one point even though the prices per pound are different.

EQ

I wrote down  $y=2.50(x)$  and then I wrote down  $y=2.5(x) + .10$   
I increased the cost of the tomatoes by .10. You can see that the  $2.5(x)$  in the first equation and the  $2.5(x)$  in the second equation are the same so they share that point.

231 / 1000

The student has given an incorrect explanation.

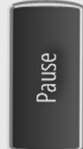
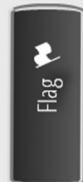
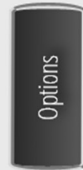

B-E.3 Response Score: 1



Question 48  
Page 1 of 2

A farmer sells tomatoes at a vegetable stand. Each pound of tomatoes sells for the same amount. The table below shows the total prices for different numbers of pounds of tomatoes sold.

Tomatoes	
Number of Pounds Sold	Total Price (\$)
2	5.00
5	12.50
9	22.50

**A.** Write an equation that describes the relationship between the number of pounds of tomatoes sold ( $x$ ) and the total price ( $y$ ), in dollars.

Eq:  $y=2.50+x$

The student has given an incorrect answer.

The farmer also sells green beans at the vegetable stand. The equation below can be used to find the total price ( $p$ ) in dollars of  $g$  pounds of green beans.

$$p = 1.75g$$

**B.** What is the total price, in dollars, of 17 pounds of green beans? Explain what the 1.75 represents in the context of the situation.

Eq: 
$$\begin{array}{r} 1.75 \\ \times 17 \\ \hline 1225 \\ +1750 \\ \hline 29.75 \end{array}$$

1.75 represents the price for the pounds

The student has given a correct answer.  
The student has given an incorrect explanation.

Review/End Test

Pause

Flag

Options

Next

Question 48  
Page 2 of 2



A farmer sells tomatoes at a vegetable stand. Each pound of tomatoes sells for the same amount. The table below shows the total prices for different numbers of pounds of tomatoes sold.

Tomatoes	
Number of Pounds Sold	Total Price (\$)
2	5.00
5	12.50
9	22.50

The farmer decides to increase the price per pound of the tomatoes. A graph is created to represent both the original equation from **part A** and a new equation based on the increased price per pound of the tomatoes.

C. Explain why the graphs representing the equations will share one point even though the prices per pound are different.

eci

Two lines share one point when the two lines intersect like an X.

65 / 1000

The student has given an incorrect explanation.

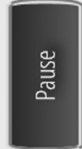
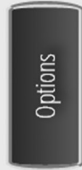



B-E.3 Response Score: 0



Question 48  
Page 1 of 2

**A.** Write an equation that describes the relationship between the number of pounds of tomatoes sold ( $x$ ) and the total price ( $y$ ), in dollars.

Eq. pounds(x)=price(y)

The student has given an incorrect answer.

The farmer also sells green beans at the vegetable stand. The equation below can be used to find the total price ( $p$ ) in dollars of  $g$  pounds of green beans.

$$p = 1.75g$$

Options

**B.** What is the total price, in dollars, of 17 pounds of green beans? Explain what the 1.75 represents in the context of the situation.

Eq. 17.00  
+ 1.75  
\$18.75  
1.75 is the price

The student has given an incorrect answer.  
The student has given an incorrect explanation.

29 / 1000

Options

Review/End Test

A farmer sells tomatoes at a vegetable stand. Each pound of tomatoes sells for the same amount. The table below shows the total prices for different numbers of pounds of tomatoes sold.

Tomatoes	
Number of Pounds Sold	Total Price (\$)
2	5.00
5	12.50
9	22.50

Options

Pause

The student has given an incorrect answer.  
The student has given an incorrect explanation.

Options

Flag

The student has given an incorrect answer.  
The student has given an incorrect explanation.

Options

Review/End Test

The student has given an incorrect answer.  
The student has given an incorrect explanation.

Options



Question 48  
Page 2 of 2



A farmer sells tomatoes at a vegetable stand. Each pound of tomatoes sells for the same amount. The table below shows the total prices for different numbers of pounds of tomatoes sold.

**Tomatoes**

Number of Pounds Sold	Total Price (\$)
2	5.00
5	12.50
9	22.50

The farmer decides to increase the price per pound of the tomatoes. A graph is created to represent both the original equation from **part A** and a new equation based on the increased price per pound of the tomatoes.

C. Explain why the graphs representing the equations will share one point even though the prices per pound are different.

eci

Prices per pound can be different. \$5.00 is not \$12.50 is not 22.50.

68 / 1000

The student has given an incorrect explanation.

Review/End Test

Pause

Flag

Options

Back

**FOURTH OPEN-ENDED QUESTION****C-G.1**

49. A parallelogram is drawn on a grid. The area of the parallelogram is 24 square units.

- A. On the grid, draw a rectangle, a triangle, and a trapezoid that each have the same area as the parallelogram. Make sure the vertices of each of the shapes are at the intersections of grid lines. Show or explain that the area of each shape is the same as the area of the parallelogram.

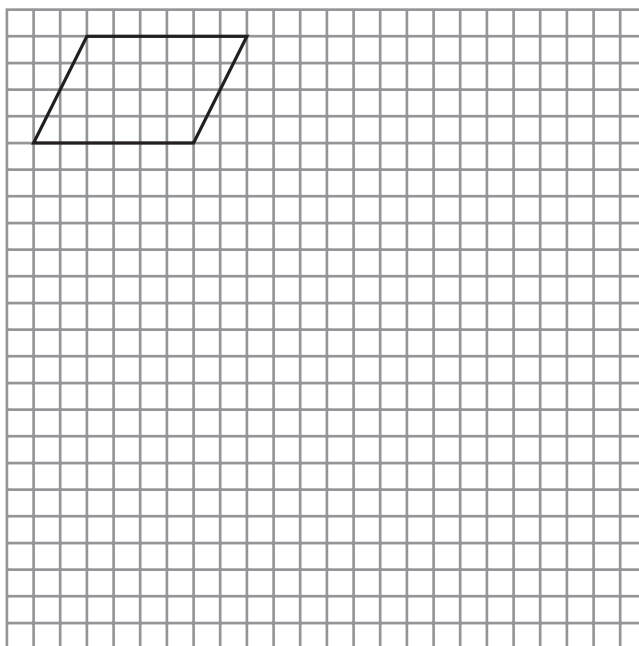

**Key**

□ = 1 square unit

**Go to the next page to finish question 49.**

49. **Continued.** Please refer to the previous page for task explanation.

**B.** Explain why a square with the same area as the parallelogram and with its vertices at the intersections of grid lines cannot be drawn.

**ITEM-SPECIFIC SCORING GUIDELINE**

**Question #49**

**Grade 6**

**Assessment Anchor this item will be reported under:**

M06.C-G.1— Solve real-world and mathematical problems involving area, surface area, and volume.

**Specific Anchor Descriptor addressed by this item:**

M06.C-G.1.1—Find area, surface area, and volume by applying formulas and using various strategies.

**Scoring Guide:**

Score	In this item, the student –
4	Demonstrates a thorough understanding of how to solve real-world and mathematical problems involving area, surface area, and volume by correctly solving problems and clearly explaining procedures.
3	Demonstrates a general understanding of how to solve real-world and mathematical problems involving area, surface area, and volume by correctly solving problems and clearly explaining procedures with only minor errors or omissions.
2	Demonstrates a partial understanding of how to solve real-world and mathematical problems involving area, surface area, and volume by correctly performing a significant portion of the required task.
1	Demonstrates minimal understanding of how to solve real-world and mathematical problems involving area, surface area, and volume.
0	The response has no correct answer and insufficient evidence to demonstrate any understanding of the mathematical concepts and procedures as required by the task. Response may show only information copied from the question.
Non-Scorables	B – Blank R – Refusal K – Off task/topic F – Foreign language U – Illegible

**Top Scoring Student Response And Training Notes:**

Score	Description
4	Student earns 4 points.
3	Student earns 3.0 – 3.5 points.
2	Student earns 2.0 – 2.5 points.
1	Student earns 0.5 – 1.5 points. OR Student demonstrates minimal understanding of how to solve real-world and mathematical problems involving area, surface area, and volume.
0	Response is incorrect or contains some correct work that is irrelevant to the skill or concept being measured.

Question #49

Top Scoring Response:

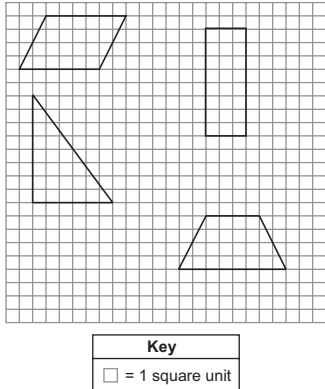
Part A Answer	
What?	Why?
<p>Answers may vary. Student must draw a triangle, a rectangle and a trapezoid, each with an area of 24 square units.</p> <p><b>Sample Response:</b></p> 	<p><b>Sample Work:</b>                      Rectangle: <math>A = 8 \cdot 3 = 24</math>                      Triangle: <math>A = \frac{1}{2}(8 \cdot 6) = 24</math>                      Trapezoid: <math>A = \frac{1}{2}(8 + 4)(4) = 24</math></p> <p><b>OR</b></p> <p><b>Sample Explanation:</b>  <math>A = 6 \cdot 4 = 24</math>                      Draw a rectangle that is 3 units by 8 units, so its area is also 24 square units.  <math>A = 8 \cdot 3 = 24</math>                      Draw a triangle with a base of 8 units and a height of 6 units, so its area is 24 square units.  <math>A = \frac{1}{2}(8 \cdot 6) = 24</math>                      Draw a trapezoid with one base of 8 units, the other base of 4 units, and a height of 4 units, so it has an area of 24 square units.  <math>A = \frac{1}{2}(8 + 4)(4) = 24</math></p> <p><b>OR equivalent</b></p>

(3 score points)

- ½ point for each correct drawing
- ½ point for each complete support

Part B Answer	
What?	Why?
	<p><b>Sample Explanation:</b>                      The parallelogram has an area of 24 square units. So the square must have an area of 24 square units. In a square all the sides are the same length. Since the vertices of the square need to be at the intersections of grid lines, the lengths of the sides of the square need to be whole numbers. Using whole numbers, only squares of 1, 4, 9, 16, 25, 36, 49, 64, 81, etc., square units are possible. There is no whole number that when multiplied by itself equals 24, so a square with whole number side lengths and an area of 24 square units is not possible.</p> <p><b>OR equivalent</b></p>

(1 score point)

- 1 point for complete explanation
- OR ½ point for correct but incomplete explanation

**FOURTH OPEN-ENDED QUESTION RESPONSES**

**C-G.1 Response Score: 4**

49. A parallelogram is drawn on a grid. The area of the parallelogram is 24 square units.

A. On the grid, draw a rectangle, a triangle, and a trapezoid that each have the same area as the parallelogram. Make sure the vertices of each of the shapes are at the intersections of grid lines. Show or explain that the area of each shape is the same as the area of the parallelogram.

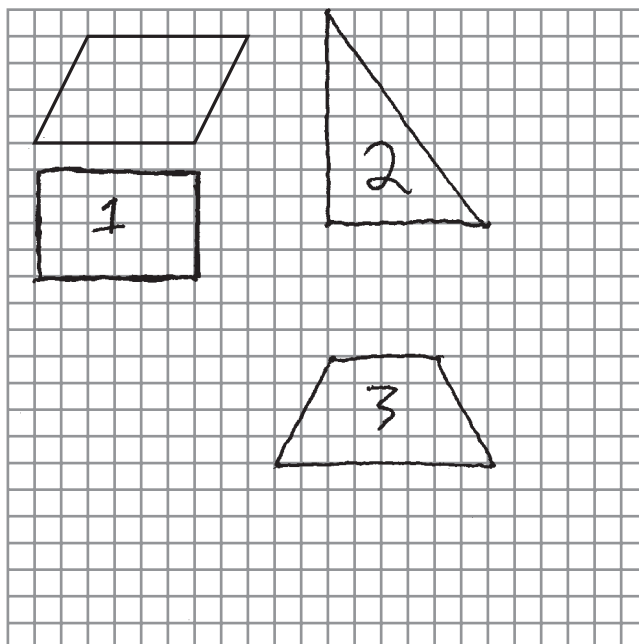

Key	
□	= 1 square unit

$$A_1 = lw = 6 \cdot 4 = 24 \text{ sq units}$$

$$A_2 = \frac{1}{2}bh = \frac{1}{2} \cdot 6 \cdot 8 = 24 \text{ sq units}$$

$$A_3 = \frac{1}{2}(b_1 + b_2)h = \frac{1}{2}(4 + 8) \cdot 4 = 24$$

The student has given three correct drawings  
The student has shown correct support for all three

**Go to the next page to finish question 49.**

49. **Continued.** Please refer to the previous page for task explanation.

- B.** Explain why a square with the same area as the parallelogram and with its vertices at the intersections of grid lines cannot be drawn.

The key says each square unit is one whole unit on a side. There are no fractions. The area of a square is side times side or  $s \times s$ . It's not possible to get  $s \times s = 24$ .  $4 \times 4$  is 16 and  $5 \times 5$  is 25. There is no whole number between 4 and 5.

The student has correct and complete explanation

C-G.1 Response Score: 3

49. A parallelogram is drawn on a grid. The area of the parallelogram is 24 square units.

A. On the grid, draw a rectangle, a triangle, and a trapezoid that each have the same area as the parallelogram. Make sure the vertices of each of the shapes are at the intersections of grid lines. Show or explain that the area of each shape is the same as the area of the parallelogram.

$6 \times 4 = 24$   
 $\frac{1}{2} \times 4 \times 12 = 24$   
 $\frac{1}{2} \times 3 \times (6+10) =$   
 $\frac{1}{2} \times 3 \times 16 =$   
 $3 \times 8 = 24$

**Key**  
 □ = 1 square unit

The student has given three correct drawings  
 The student has shown correct support for all three

Go to the next page to finish question 49.



49. **Continued.** Please refer to the previous page for task explanation.

- B.** Explain why a square with the same area as the parallelogram and with its vertices at the intersections of grid lines cannot be drawn.

*I know that there are no same numbers when multiplied together that equal 24.*

The student has correct but incomplete explanation

C-G.1 Response Score: 2

49. A parallelogram is drawn on a grid. The area of the parallelogram is 24 square units.

A. On the grid, draw a rectangle, a triangle, and a trapezoid that each have the same area as the parallelogram. Make sure the vertices of each of the shapes are at the intersections of grid lines. Show or explain that the area of each shape is the same as the area of the parallelogram.

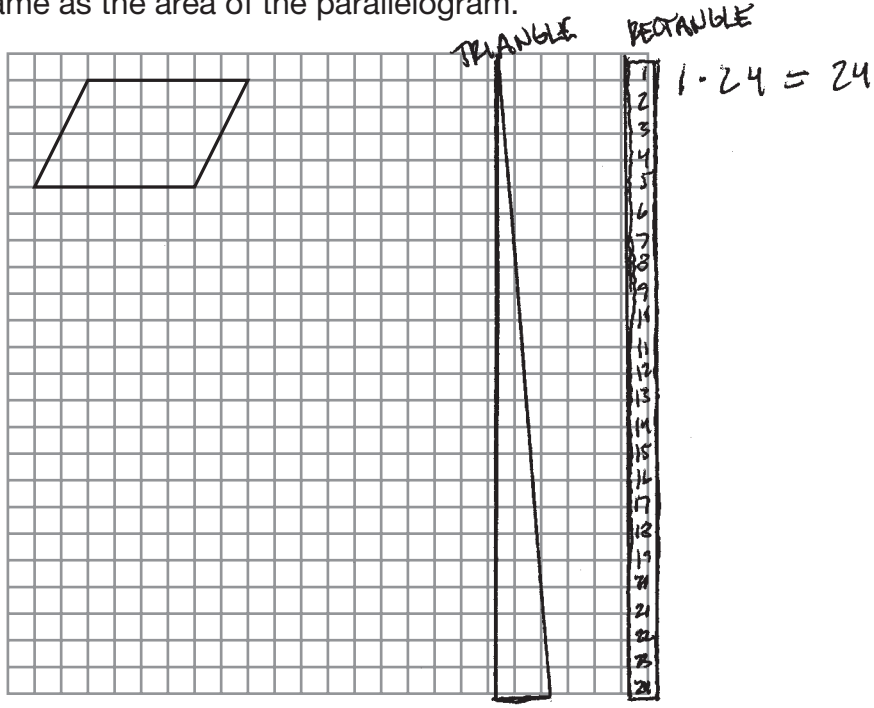

**Key**  
 □ = 1 square unit

$$A = \frac{1}{2} h (b_1 + b_2)$$

$$2 \cdot 24 = 48$$

$$48 \div 2 = 24$$

The student has given two correct drawings  
 The student has shown correct support for the two of them

Go to the next page to finish question 49.

49. **Continued.** Please refer to the previous page for task explanation.

- B.** Explain why a square with the same area as the parallelogram and with its vertices at the intersections of grid lines cannot be drawn.

A SQUARE IS A PARALLELOGRAM WHEN ALL THE SIDES ARE EQUAL  
AND ALL THE ANGLES ARE RIGHT ANGLES.

The student has incorrect explanation

C-G.1 Response Score: 1

49. A parallelogram is drawn on a grid. The area of the parallelogram is 24 square units.

- A. On the grid, draw a rectangle, a triangle, and a trapezoid that each have the same area as the parallelogram. Make sure the vertices of each of the shapes are at the intersections of grid lines. Show or explain that the area of each shape is the same as the area of the parallelogram.

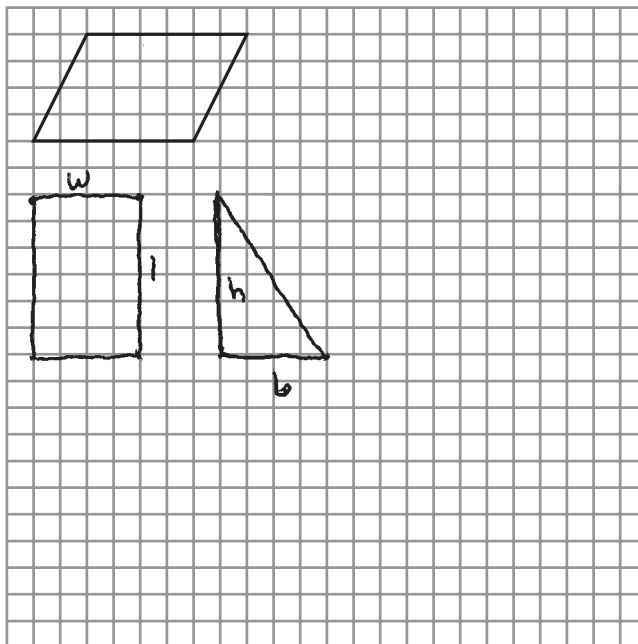

$A = lw$   
 $A = 6 \times 4$   
 $A = 24$

Key	
	= 1 square unit

$A = bh = 6 \cdot 4 = 24$   
 $A = \frac{1}{2} h (b_1 + b_2)$

The student has given one correct drawing  
 The student has shown correct support for the one

Go to the next page to finish question 49.

49. **Continued.** Please refer to the previous page for task explanation.

- B.** Explain why a square with the same area as the parallelogram and with its vertices at the intersections of grid lines cannot be drawn.

Grid lines cannot be drawn because a square has right angles and a parallelogram does not have right angles.

The student has incorrect explanation

C-G.1 Response Score: 0

49. A parallelogram is drawn on a grid. The area of the parallelogram is 24 square units.

A. On the grid, draw a rectangle, a triangle, and a trapezoid that each have the same area as the parallelogram. Make sure the vertices of each of the shapes are at the intersections of grid lines. Show or explain that the area of each shape is the same as the area of the parallelogram.

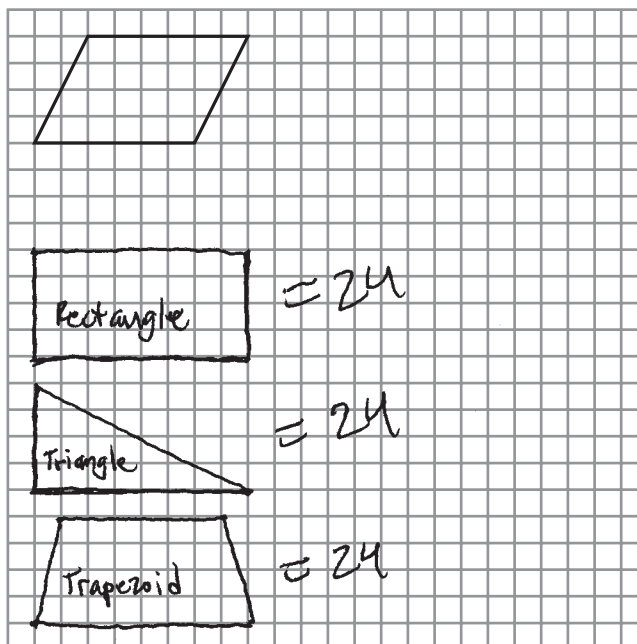

Key	
	= 1 square unit

The student has given three incorrect drawings  
The student has shown no correct support

Go to the next page to finish question 49.

49. **Continued.** Please refer to the previous page for task explanation.

- B.** Explain why a square with the same area as the parallelogram and with its vertices at the intersections of grid lines cannot be drawn.

A square with the same area as the parallelogram and with its vertices at the intersections of grid lines cannot be drawn because grid lines can never be parallel. They can only be perpendicular. The sides of squares are always perpendicular. The sides of parallelograms are always parallel.

The student has incorrect explanation

**FIFTH OPEN-ENDED QUESTION****D-S.1.1**

50. The data set below shows the number of photographs taken by each of 10 students on a field trip.

45 60 58 60 45 65 54 45 39 60

- A. Create a box-and-whisker plot to represent the data set using the line below.

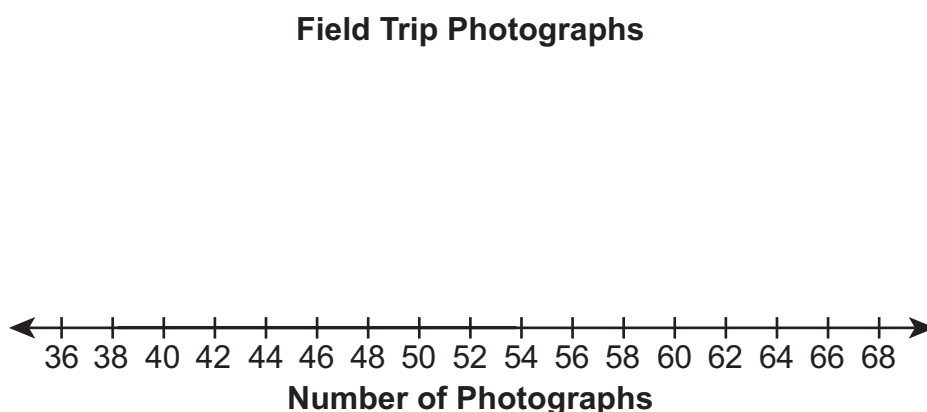

- B. Without calculating the actual **mean** of the 10 data points, explain how the box-and-whisker plot could be used to conclude that the **mean** of the 10 data points is less than the **median** of the 10 data points.

**Go to the next page to finish question 50.**



50. **Continued.** Please refer to the previous page for task explanation.

The two teachers on the field trip also took photographs. When the two additional numbers of photographs are included in the data set, the maximum value increases by 2. The minimum and quartile values do not change.

- C.** Determine a possible number of photographs that each teacher took. Show or explain all your work.

**ITEM-SPECIFIC SCORING GUIDELINE**

**Question #50**

**Grade 6**

**Assessment Anchor this item will be reported under:**

M06.D-S.1—Demonstrate understanding of statistical variability by summarizing and describing distributions.

**Specific Anchor Descriptor addressed by this item:**

M06.D-S.1.1—Display, analyze, and summarize numerical data sets in relation to their context.

**Scoring Guide:**

Score	In this item, the student –
4	Demonstrates a thorough understanding of statistical variability by summarizing and describing distributions by correctly solving problems and clearly explaining procedures.
3	Demonstrates a general understanding of statistical variability by summarizing and describing distributions by correctly solving problems and clearly explaining procedures with only minor errors or omissions.
2	Demonstrates a partial understanding of statistical variability by summarizing and describing distributions by correctly performing a significant portion of the required task.
1	Demonstrates minimal understanding of statistical variability by summarizing and describing distributions.
0	The response has no correct answer and insufficient evidence to demonstrate any understanding of the mathematical concepts and procedures as required by the task. Response may show only information copied from the question.
Non-Scorables	B – Blank R – Refusal K – Off task/topic F – Foreign language U – Illegible

**Top Scoring Student Response And Training Notes:**

Score	Description
4	Student earns 4 points.
3	Student earns 3.0 – 3.5 points.
2	Student earns 2.0 – 2.5 points.
1	Student earns 0.5 – 1.5 points. OR Student demonstrates minimal understanding of statistical variability by summarizing and describing distributions.
0	Response is incorrect or contains some correct work that is irrelevant to the skill or concept being measured.

Question #50

Top Scoring Response:

Part A Answer	
What?	Why?

(1 score point)

1 point for correct box-and-whisker plot

Part B Answer	
What?	Why?
	<p><b>Sample Explanation:</b> The box and whisker plot shows that the median is skewed somewhat to the right of center of the data distribution, which means that the half of the data set below the median is more spread out than the half above the median. When this happens, the mean of the data set is pulled to the left of the median, making it less than the median.</p> <p><b>OR equivalent</b></p>

(1 score point)

1 point for complete explanation  
OR ½ point for correct but incomplete explanation

Part C Answer	
What?	Why?
<p>Answers may vary. Students must have two numbers: 67 and any number of photographs from 39 to 54.</p> <p><b>Sample Response:</b> 67 (photographs) 48 (photographs)</p>	<p><b>Sample Explanation:</b> Since the maximum value in the data set is 65 and that value increases by 2, one of the teachers took 67 photographs. If I want to leave everything else the same, I can pick Q1 and nothing else will change.</p> <p><b>OR</b> &lt;The student includes a data set with quartiles to show nothing else changed.&gt;</p> <p><b>OR equivalent</b></p>

(2 score points)

½ point for each correct answer  
1 point for complete explanation  
OR ½ point for correct but incomplete explanation

## FIFTH OPEN-ENDED QUESTION RESPONSES

## D-S.1.1 Response Score: 4

50. The data set below shows the number of photographs taken by each of 10 students on a field trip.

45 60 58 60 45 65 54 45 39 60

- A. Create a box-and-whisker plot to represent the data set using the line below.

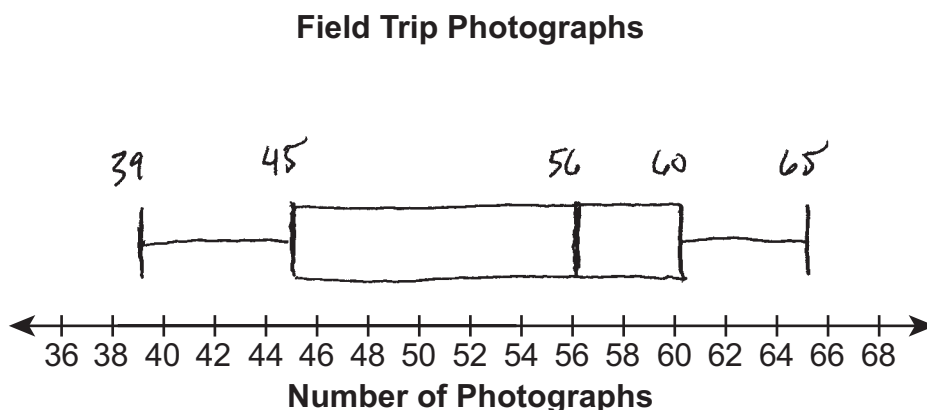

The student has given a correct box and whisker plot

- B. Without calculating the actual **mean** of the 10 data points, explain how the box-and-whisker plot could be used to conclude that the **mean** of the 10 data points is less than the **median** of the 10 data points.

*The median is skewed to the right of center. (It's not around 52, but at 56.) This means the data below the median is more spread out than the data above the median. This would pull the mean to the left of the median.*

The student has given a correct explanation

Go to the next page to finish question 50.

50. **Continued.** Please refer to the previous page for task explanation.

The two teachers on the field trip also took photographs. When the two additional numbers of photographs are included in the data set, the maximum value increases by 2. The minimum and quartile values do not change.

- C. Determine a possible number of photographs that each teacher took. Show or explain all your work.

67 and 45

$65 + 2 = 67$  which is my new maximum  
 39 45 45 45 45 54 58 60 60 60 65 67 is my new set  
 of data with another 45 included. None of this  
 changes the minimum or quartile values.

The minimum is still 39 and the 1<sup>st</sup> quartile  
 is the average of 45 and 45 which is still 45.  
 The median is still the average of 54 and 58  
 which is 56. The 3<sup>rd</sup> quartile is the average of  
 60 and 60 which is still 60.

The student has given two correct answers  
 The student has shown complete support

D-S.1.1 Response Score: 3

50. The data set below shows the number of photographs taken by each of 10 students on a field trip.

45 60 58 60 45 65 54 45 39 60

A. Create a box-and-whisker plot to represent the data set using the line below.

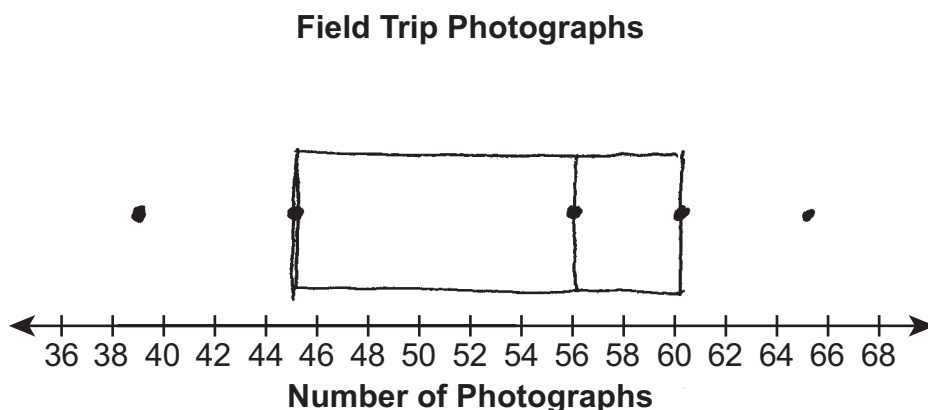

The student has given a correct box and whisker plot

B. Without calculating the actual **mean** of the 10 data points, explain how the box-and-whisker plot could be used to conclude that the **mean** of the 10 data points is less than the **median** of the 10 data points.

THE MEDIAN IS FARTHER TO THE RIGHT OF THE MIDDLE. IT'S NOT CENTERED IN THE RANGE. THERE'S MORE DATA SPREAD OUT FURTHER TO THE LEFT OF THE MEDIAN WHICH MEANS THAT THERE WILL BE LOWER NUMBERS TO ADD UP TO MAKE THE TOTAL THAT IS DIVIDED BY 10 TO GET A MEAN THIS IS GOING TO BE LOWER, THUS, LESS THAN THE MEDIAN

The student has given a correct explanation

Go to the next page to finish question 50.

50. **Continued.** Please refer to the previous page for task explanation.

The two teachers on the field trip also took photographs. When the two additional numbers of photographs are included in the data set, the maximum value increases by 2. The minimum and quartile values do not change.

- C. Determine a possible number of photographs that each teacher took. Show or explain all your work.

67, 41

THE NEW MAXIMUM COMES FROM ADDING 2 TO THE OLD MAXIMUM OF 65. I PICKED 41 BECAUSE ADDING 2 MEANS NOTHING WILL CHANGE.

The student has given two correct answers  
The student has shown no correct support

## D-S.1.1 Response Score: 2

50. The data set below shows the number of photographs taken by each of 10 students on a field trip.

45 60 58 60 45 65 54 45 39 60

- A. Create a box-and-whisker plot to represent the data set using the line below.

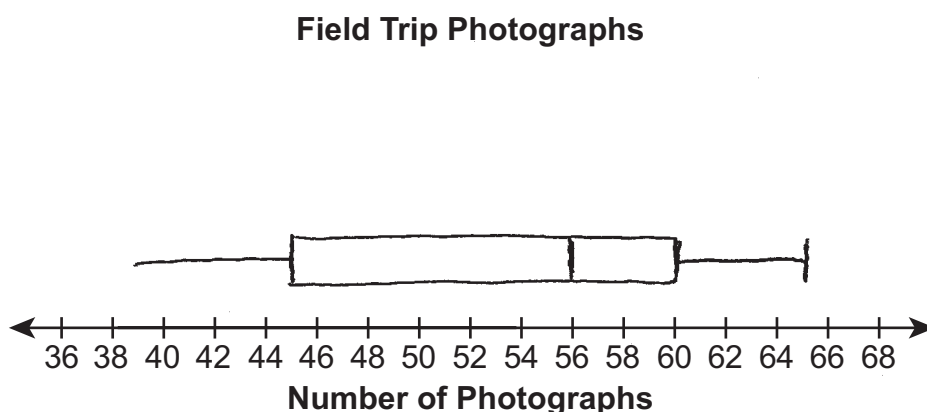

The student has given a correct box and whisker plot

- B. Without calculating the actual **mean** of the 10 data points, explain how the box-and-whisker plot could be used to conclude that the **mean** of the 10 data points is less than the **median** of the 10 data points.

*I saw that the median wasn't in the middle of my box plot. And, it wasn't in the middle of my IQR. This is why the mean is less than the median.*

The student has given an incorrect explanation

Go to the next page to finish question 50.



50. **Continued.** Please refer to the previous page for task explanation.

The two teachers on the field trip also took photographs. When the two additional numbers of photographs are included in the data set, the maximum value increases by 2. The minimum and quartile values do not change.

- C. Determine a possible number of photographs that each teacher took. Show or explain all your work.

67 and 50

I tried both numbers and they worked.

The student has given two correct answers  
The student has shown no correct support

D-S.1.1 Response Score: 1

50. The data set below shows the number of photographs taken by each of 10 students on a field trip.

45 60 58 60 45 65 54 45 39 60

A. Create a box-and-whisker plot to represent the data set using the line below.

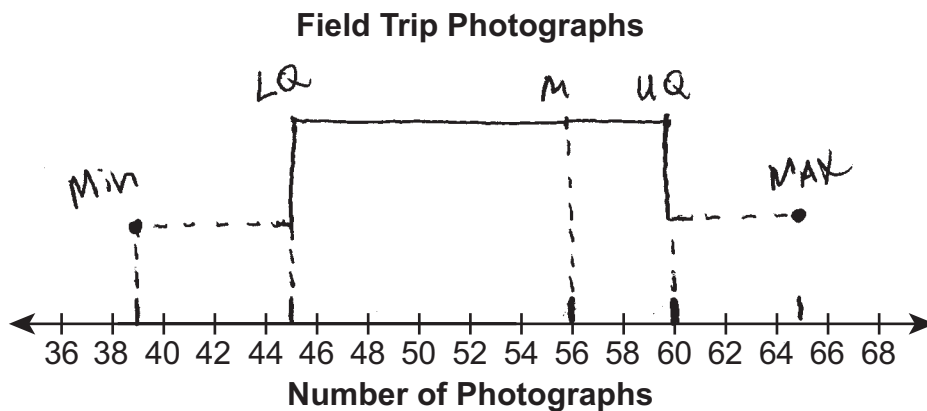

The student has given a correct box and whisker plot

B. Without calculating the actual **mean** of the 10 data points, explain how the box-and-whisker plot could be used to conclude that the **mean** of the 10 data points is less than the **median** of the 10 data points.

*I know the mean is the average and the median isn't the average and means are always in the middle and the middle is 52 which is not 56.*

The student has given an incorrect explanation

Go to the next page to finish question 50.

50. **Continued.** Please refer to the previous page for task explanation.

The two teachers on the field trip also took photographs. When the two additional numbers of photographs are included in the data set, the maximum value increases by 2. The minimum and quartile values do not change.

- C. Determine a possible number of photographs that each teacher took. Show or explain all your work.

$$65 + 2 = 67$$

The student has given one correct answer  
The student has shown no support

D-S.1.1 Response Score: 0

50. The data set below shows the number of photographs taken by each of 10 students on a field trip.

45 60 58 60 45 65 54 45 39 60

A. Create a box-and-whisker plot to represent the data set using the line below.

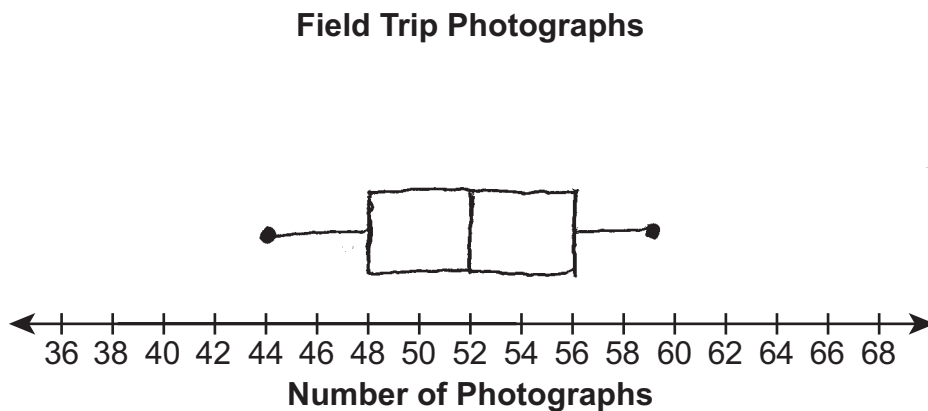

The student has given an incorrect box and whisker plot

B. Without calculating the actual **mean** of the 10 data points, explain how the box-and-whisker plot could be used to conclude that the **mean** of the 10 data points is less than the **median** of the 10 data points.

The median is 52. I rounded the mean and got 53. 53 is not less than 52.

The student has given an incorrect explanation

Go to the next page to finish question 50.

50. **Continued.** Please refer to the previous page for task explanation.

The two teachers on the field trip also took photographs. When the two additional numbers of photographs are included in the data set, the maximum value increases by 2. The minimum and quartile values do not change.

- C. Determine a possible number of photographs that each teacher took. Show or explain all your work.

I added 2 to 60 and got 62. I added 2 plus 62 and I got 64.

The student has given two incorrect answers  
The student has shown no correct support

# **PSSA Grade 6 Mathematics Item and Scoring Sampler**

**Copyright © 2015 by the Pennsylvania Department of Education. The materials contained in this publication may be duplicated by Pennsylvania educators for local classroom use. This permission does not extend to the duplication of materials for commercial use.**