

State ID	Employee Name	Areas of Certification Type of Certificate	Grades Teaching or Serving
5168579	Allen, Betty A	Instructional 2 Elementary K-6 (2810);Instructional 2 Early Childhood N-3 (2840)	Assistant Principal - High School
6408509	Bryan, Carol L	Instructional 2 Elementary K-6 (2810)	Teacher - 3rd Grade Social Studies
1637383	Cross, Amber Faith	Instructional 2 Elementary K-6 (2810);Instructional 2 Family-Consumer Sci PK-12 (5600);Instructional 2 Reading Specialist PK-12 (7650);Instructional 2 Ment and/or Phys Handicapped K-12 (9235)	Remedial Specialist - Math - 3rd Grade; Remedial Specialist - Math - 4th Grade; Remedial Specialist - Math - 5th Grade
2804139	Curry, Denise Michele	Instructional 2 Mathematics 7-12 (6800);Instructional 2 Chemistry 7-12 (8420)	Instructional Coach - General Education - Elementa
3105632	Howe, Erin M	Instructional 2 Bus-Computer-Info Tech PK-12 (1603);Instructional 2 English 7-12 (3230);Instructional 2 Mathematics 7-12 (6800);Instructional 2 Biology 7-12 (8405);Instructional 2 Social Studies 7-12 (8875);Instructional 2 Special Education PK-12 (9225)	Remedial Specialist - Math - 6th Grade; Remedial Specialist - Math - 7th Grade
3132359	Puskar, Kathryn P	Endorsement 1 Instructional Coach PK-12 (1182);Instructional 2 Mid-Level Mathematics 6-9 (2860)	Teacher - 3rd Grade Math
5365472	Scheib, Alyson Jaye	Instructional 1 Grades 4-8 (All subjects 4-6 ELA & Reading (3100);Instructional 1 Special Education PK-8 (9226);Instructional 1 Special Education Expansion 7-12 (9229)	Operations Coordinator - Middle School
2427256	Cukauskas, Michelle Elizabeth	Instructional 2 Social Studies 7-12 (8875)	Assistant Director - Special Education - K-8
2169062	Edmundson, Megan Amanda	Instructional 1 Grades PK-4 (2825)	Teacher - Literary Analysis and Composition I
6747158	Feldhaus, Daniel	Instructional 1 Elementary K-6 (2810)	Director - State Testing & Data
8901681	Purdy, Marcy L	Private School - Teacher English: Sec. Ed. 9-12 (13230);Instructional 1 Communications 7-12 (3200);Instructional 1 English 7-12 (3230)	Teacher - Algebra II; Teacher - Honors Algebra II
9630187	Dupes, Linda D	Instructional 2 Spanish PK-12 (4490)	Teacher - 6th Grade English Language Arts
9471057	McEwen, Elizabeth Mary	Administrative 2 Principal PK-12 (1115);Instructional 2 Elementary K-6 (2810);Instructional 2 Mid-Level English 6-9 (2850);Instructional 2 Reading Specialist PK-12 (7650)	Instructional Coach - General Education - Middle S
3078293	Miller, Jeffrey Paul	Instructional 2 English 7-12 (3230)	Principal - High School
2383109	Smith, Tonya L	Educational Specialist 2 Secondary School Counselor 7-12 (1837)	Instructional Coach - High School - English
1419058	Buffington, Eric G	Instructional 2 Elementary K-6 (2810);Instructional 2 Early Childhood N-3 (2840);Program Specialist English as a Second Language (ESL) PK-12 (4499);Instructional 2 Reading Specialist PK-12 (7650);Instructional 2 Special Education PK-12 (9225)	Assistant Principal - Middle School
5843602	McCrea, Julie Ann	Instructional 2 English 7-12 (3230)	Instructional Coach - High School - Science
3013026	Platt, Keith A	Administrative 1 Principal PK-12 (1115);Instructional 2 Mathematics 7-12 (6800)	Teacher - Physical Education
9863512	Silberman, Heather S	Administrative 1 Principal PK-12 (1115);Instructional 2 Elementary K-6 (2810)	Teacher - Learning Support - HS
9895439	Whippo, Janet Demay	Instructional 2 Elementary K-6 (2810);Instructional 2 Special Education PK-12 (9225)	Remedial Specialist - Reading - 3rd Grade; Remedial Specialist - Reading - 4th Grade; Remedial Specialist - Reading - 5th Grade

State ID	Employee Name	Areas of Certification Type of Certificate	Grades Teaching or Serving
7372496	McCauley, Tamara J	Endorsement Online Instruction Program PK-12 (1184);Instructional 2 Elementary K-6 (2810);Instructional 2 Mid-Level Mathematics 6-9 (2860);Instructional 2 Mid-Level Science 6-9 (2880);Instructional 2 Mathematics 7-12 (6800);Instructional 2 Biology 7-12 (8405);Instructional 2 Special Education PK-12 (9225)	Teacher - 5th Grade Social Studies
5976482	Eberly, Jessica Nicole	Instructional 1 Health & Physical Educ PK-12 (4805);Instructional 1 Special Education PK-8 (9226)	Remedial Specialist - Math - 3rd Grade
2579716	Spratt, Leslie D	Educational Specialist 1 Inst Technology Specialist PK-12 (1825);Instructional 2 Biology 7-12 (8405)	Teacher - Emotional Support - K-8
2586973	Johnston, Jennifer A	Instructional 1 Elementary K-6 (2810);Instructional 1 Family-Consumer Sci PK-12 (5600);Instructional 1 Reading Specialist PK-12 (7650)	Teacher - 3rd Grade Science
2083212	Quisito, Tara Ann	Instructional 2 English 7-12 (3230);Instructional 2 Special Education PK-12 (9225)	Guidance Counselor - High School
9397186	Soda, Lory A	Instructional 1 Grades 4-8 (All subjects 4-6 Math 7-8) (3100);Instructional 1 Grades 4-8 (All subjects 4-6, S Stud 7-8) (3100SS);Instructional 1 Social Studies 7-12 (8875)	Teacher - Smart Futures
5167965	Shebeck, Regan Lynne	Instructional 2 Grades PK-4 (2825);Instructional 2 Special Education PK-8 (9226)	Assistant Principal - High School
5893439	Hoffman Long, Melissa R	Instructional 2 Grades PK-4 (2825);Instructional 2 Reading Specialist PK-12 (7650)	Teacher - Earth Science; Teacher - Honors Earth Science
5702327	Bayly, Angela Michelle	Instructional 2 General Science 7-12 (8450)	Instructional Coach - General Education - Middle S
3189451	Tilsner, Michelle	Instructional 2 Art PK-12 (1405);Instructional 2 English 7-12 (3230);Supervisory Supvr Special Education PK-12 (9215);Instructional 2 Special Education PK-12 (9225)	Remedial Specialist - Reading - 6th Grade; Remedial Specialist - Reading - 7th Grade
5732496	Buss, Jennifer Ann	Instructional 2 Social Studies 7-12 (8875)	Teacher - Learning Support - K-8
6131985	Feely, Scott L	Instructional 1 Art PK-12 (1405);Instructional 1 English 7-12 (3230)	Family Coach
4891748	Floyd, Michael S	Instructional 2 Elementary K-6 (2810);Instructional 2 Special Education PK-12 (9225)	Education Technology Specialist
6326152	Grant, Jamie Marie	Instructional 2 Elementary K-6 (2810);Instructional 2 Mid-Level Mathematics 6-9 (2860);Instructional 2 Mid-Level Science 6-9 (2880)	Instructional Coach - General Education - Elementa
9682934	Johnson, Maryann	Instructional 2 Social Studies 7-12 (8875)	Assistant Director - Special Education - K-8
8304964	Karp, Barbara Myers	Educational Specialist 2 Home and School Visitor PK-12 (1850);Educational Specialist 2 School Social Worker PK-12 (1851)	Teacher - Honors Modern World Studies; Teacher - Modern World Studies
8152565	Maines, Beth Ann	Educational Specialist 1 Secondary School Counselor 7-12 (1837);Instructional 2 Mathematics 7-12 (6800);Instructional 2 Physics 7-12 (8470)	Teacher - 5th Grade Science
5038104	Buckwalter, Jodeen E	Instructional 1 Elementary K-6 (2810);Instructional 1 Special Education PK-8 (9226)	Teacher - Learning Support - HS

State ID	Employee Name	Areas of Certification Type of Certificate	Grades Teaching or Serving
1504512	Shaffer, Lauren Elizabeth	Instructional 2 Elementary K-6 (2810);Instructional 2 Special Education PK-12 (9225)	Curriculum Coordinator
4517079	Spess, Chantel A	Instructional 1 Grades PK-4 (2825)	Teacher - World History
8239726	Whitebread, Autumn Lee	Instructional 2 Early Childhood N-3 (2840);Instructional 2 Special Education PK-12 (9225)	Teacher - 4th Grade Science
9871308	Mirth, Richard Michael	Educational Specialist 1 Inst Technology Specialist PK-12 (1825);Instructional 2 English 7-12 (3230);Instructional 2 Environmental Educ PK-12 (4820);Instructional 2 Technology Education PK-12 (6075);Instructional 2 Biology 7-12 (8405);Instructional 2 General Science 7-12 (8450)	Guidance Counselor - High School
2946235	Cadwallader, Amy Beth	Instructional 2 English 7-12 (3230);Instructional 2 Special Education PK-12 (9225)	Teacher - 8th Grade Math
6953949	Richardson, Colleen Shannon	Instructional 2 Elementary K-6 (2810);Instructional 2 Mathematics 7-12 (6800)	MTSS Coordinator - Middle School
4294964	Kunitsky, Diane Marie	Instructional 1 Elementary K-6 (2810);Instructional 1 Ment and/or Phys Handicapped K-12 (9235)	Teacher - Chemistry
3127261	Rockower, Mindy Sharon	Educational Specialist 1 Elementary School Counselor K-6 (1836);Educational Specialist 1 Secondary School Counselor 7-12 (1837);Instructional 1 Elementary K-6 (2810);Program Specialist English as a Second Language (ESL) PK-12 (4499)	Guidance Counselor - High School
4187263	Pytko, Jonathan Clayton	Administrative 2 Principal PK-12 (1115);Instructional 2 Elementary K-6 (2810);Instructional 2 Reading Specialist PK-12 (7650)	Teacher - AP U.S. Government and Politics; Teacher - U.S. Government and Politics; Teacher - Modern World Studies
6798439	Nichols, Christina Marie	Instructional 2 Mid-Level Mathematics 6-9 (2860);Instructional 2 Music PK-12 (7205)	Teacher - Earth Science
8727359	Camarda, Kate Virginia	Instructional 1 Grades PK-4 (2825)	ESL Coordinator
8961729	Fisher Clark, Jennifer Jo	Instructional 2 General Science 7-12 (8450)	Director - Special Education - K-8
3109573	Pagliei, Lynn Marie	Instructional 2 Bus-Computer-Info Tech PK-12 (1603);Private School - Teacher Mathematics: Sec. Ed. 9-12 (16800);Instructional 2 Mathematics 7-12 (6800)	Teacher - Learning Support - HS
7390124	Mulvey, Joanne C	Instructional 2 Special Education PK-12 (9225)	Teacher - Pre-Calculus/Trigonometry
6941361	Basso, Maura J	Instructional 1 Grades PK-4 (2825);Instructional 1 Grades 4-8 (All subjects 4-6 ELA & Reading (3100);Instructional 1 Special Education PK-8 (9226)	Teacher - Learning Support - K-8
1963475	Bird, Brandon M	Instructional 2 Health & Physical Educ PK-12 (4805)	Teacher - 7th Grade Science
8407809	Harvey, Barbara N	Instructional 2 Mathematics 7-12 (6800);Instructional 2 Special Education PK-12 (9225)	Teacher - 7th Grade Math
1087343	Hamburger, Karen Marie	Instructional 2 Elementary K-6 (2810)	Teacher - 7th Grade Math
3930943	Marcinkiewicz, Ilyse Beth	Instructional 1 Grades PK-4 (2825)	Teacher - Pre-Algebra
1930918	Bowie, Nicole E	Instructional 1 Elementary K-6 (2810);Instructional 1 Mid-Level Mathematics 6-9 (2860)	Teacher - Nutrition and Wellness

State ID	Employee Name	Areas of Certification Type of Certificate	Grades Teaching or Serving
9536245	Kerner, Danielle L	Instructional 2 Bus-Computer-Info Tech PK-12 (1603);Instructional 2 Elementary K-6 (2810);Instructional 2 Mid-Level English 6-9 (2850);Instructional 2 Mid-Level Citiz. Ed 6-9 (2870);Instructional 2 Mid-Level Science 6-9 (2880);Instructional 2 Family-Consumer Sci PK-12 (5600);Instructional 2 Technology Education PK-12 (6075)	Teacher - AP English Language and Composition; Teacher - British and World Literature
5340726	McCracken, Kevin S	Instructional 2 Elementary K-6 (2810)	Teacher - Foundations of Music; Teacher - Music Appreciation
3464959	Bilby, Ron J	Instructional 1 Elementary K-6 (2810)	Teacher - Pre-Algebra
2784501	Patterson, Whitney Lynne	Instructional 2 Elementary K-6 (2810);Instructional 2 Mathematics 7-12 (6800)	Guidance Counselor - Middle School
9175304	Largent, Beth A	Instructional 1 Grades PK-4 (2825)	Remedial Specialist - Reading - 7th Grade; Remedial Specialist - Reading - 8th Grade
9564086	Thomas, John C	Endorsement Autism PK-12 (1180);Instructional 1 Grades PK-4 (2825);Instructional 1 Special Education PK-8 (9226)	Professional Learning Coordinator - Middle School
4162507	Scherrbaum, Jaclyn Joyce	Instructional 2 Accounting 7-12 (1610);Instructional 2 Marketing 7-12 (1640);Instructional 2 Office Technologies 7-12 (1658)	Teacher - World History; Teacher - AP Psychology; Teacher - Psychology
8793961	Calton, April Lynne	Instructional 1 Elementary K-6 (2810);Instructional 1 Grades PK-4 (2825)	Teacher - Introduction to Health Sciences; Teacher - Forensic Science
7871924	Hunkele, Terri Lee	Instructional 2 Biology 7-12 (8405);Instructional 2 Chemistry 7-12 (8420)	Teacher - Learning Support - HS
3813891	Donley, Jason M	Instructional 2 Spanish PK-12 (4490)	Teacher - Skills for Health; Teacher - Physical Education
4363026	McCormick, Heather M	Instructional 2 Special Education PK-12 (9225)	Assistant Principal - High School
7489562	Doebereiner, Julie Elizabeth	Instructional 2 Elementary K-6 (2810);Instructional 2 Special Education PK-12 (9225)	Teacher - Learning Support - K-8
4760385	Harbaugh, Amanda Blair	Instructional 2 Elementary K-6 (2810);Instructional 2 Special Education PK-12 (9225)	Curriculum Coordinator
6141696	Long, Crystal Renee	Instructional 1 Elementary K-6 (2810)	Curriculum Coordinator
1038684	Hopkins, Ellen P	Instructional HOUSSE Designation English 7-12 (3230);Instructional HOUSSE Designation Mathematics 7-12 (6800);Instructional HOUSSE Designation General Science 7-12 (8450);Instructional HOUSSE Designation Social Studies 7-12 (8875);Instructional 2 Ment and/or Phys Handicapped K-12 (9235)	Teacher - 4th Grade Social Studies
5765745	Lavacca, Deborah Ann	Administrative 1 Principal PK-12 (1115);Instructional 2 Elementary K-6 (2810);Instructional 2 Mid-Level Mathematics 6-9 (2860);Instructional 2 Mid-Level Science 6-9 (2880);Instructional 2 English 7-12 (3230)	Teacher - 2nd Grade
5981523	Bedor, Gabrielle Ann	Instructional Elementary K-6 (2810)	Teacher - 7th Grade English Language Arts; Teacher - 7th Grade Science
5430368	Hilson, Erin R	Instructional 2 Elementary K-6 (2810);Instructional 2 Mid-Level English 6-9 (2850);Instructional 2 Reading Specialist PK-12 (7650)	Assistant Principal - High School

State ID	Employee Name	Areas of Certification Type of Certificate	Grades Teaching or Serving
3902328	Lanzilotta, Kristen Fay	Instructional HOUSSE Designation Elementary K-6 (2810);Instructional 2 Special Education PK-12 (9225);Instructional 2 Speech & Language Impaired PK-12 (9265)	Teacher - 5th Grade English Language Arts
5606915	Lucier, Heidi A	Supervisory Supvr Special Education PK-12 (9215);Instructional 2 Special Education PK-12 (9225)	Teacher - 7th Grade Science
2089109	McNulty, Michael S	Instructional 1 Special Education PK-12 (9225)	Teacher - Algebra I
6893542	Pratt, Robert James	Instructional 2 Mathematics 7-12 (6800)	Teacher - 6th Grade Science
9217323	Shields, Thomas Richard	Instructional 2 Bus-Computer-Info Tech PK-12 (1603);Instructional 2 English 7-12 (3230);Instructional 2 Library Science PK-12 (6420);Instructional 2 Social Studies 7-12 (8875)	Teacher - Latin; Teacher - Archaeology
9747167	Thomas, Jennine Michelle	Instructional 2 Elementary K-6 (2810);Instructional 2 Mid-Level Mathematics 6-9 (2860);Instructional 2 English 7-12 (3230);Program Specialist English as a Second Language (ESL) PK-12 (4499)	Teacher - U.S. History
5830501	Whitmoyer, Jessica Lynn	Instructional 1 Elementary K-6 (2810)	Teacher - U.S. History
8068396	Super, Laurie Gail	Instructional 2 Elementary K-6 (2810);Instructional 2 Special Education PK-8 (9226)	Instructional Coach - Special Education - K-8
1051025	DiStefano, Katherine Carole	Instructional 2 Special Education PK-12 (9225)	Professional Learning Coordinator - High School
6109496	Williams, Marie	Instructional 2 Elementary K-6 (2810);Instructional 2 Special Education PK-12 (9225)	Operations Coordinator - High School
9625157	Keck, Marianne Christine	Instructional 2 Elementary K-6 (2810);Instructional 2 Special Education PK-12 (9225)	Teacher - Honors Physics; Teacher - Physics
5652501	McQuillan, Michael T	Instructional 2 Elementary K-6 (2810);Instructional 2 Mid-Level English 6-9 (2850);Instructional 2 Mid-Level Mathematics 6-9 (2860);Instructional 2 Mid-Level Science 6-9 (2880)	Teacher - Honors World History
9801486	Stiles, Heather	Instructional 1 Elementary K-6 (2810)	Teacher - Biology
8157431	Thayer, Barbara Jean	Instructional 1 Social Studies 7-12 (8875)	Teacher - Creative Writing; Teacher - English Foundations II; Teacher - SAT Prep English
5631375	Reiber, Kiersten Leann	Instructional 1 Spanish PK-12 (4490)	Teacher - 3rd Grade English Language Arts
5650892	Stevens, Beth Ann	Instructional 1 Grades PK-4 (2825);Instructional 1 Special Education PK-8 (9226)	Remedial Specialist - Math - 4th Grade
7353271	Bianconi, Heather Ann	Instructional 1 Grades PK-4 (2825);Instructional 1 Special Education PK-8 (9226)	Assistant Principal - Middle School
9671831	Finlayson, Rosalyn	Instructional 2 Elementary K-6 (2810)	Teacher - Gothic Literature; Teacher - Journalism
6863973	Snyder, Kelly Leigh	Instructional 2 Early Childhood N-3 (2840)	Teacher - 6th Grade English Language Arts
8940986	Karosas, Lisa Marie	Instructional 2 Social Studies 7-12 (8875)	Teacher - Chemistry
3850185	McCarthy, James V	Instructional 2 Reading Specialist PK-12 (7650);Instructional 2 Social Studies 7-12 (8875)	Teacher - Physical Education

State ID	Employee Name	Areas of Certification Type of Certificate	Grades Teaching or Serving
3765736	Jusko, Melissa Maria	Instructional 2 Elementary K-6 (2810);Instructional 2 English 7-12 (3230);Instructional 2 Special Education PK-12 (9225)	Instructional Coach - High School - Electives
7316426	McGlynn, James G	Instructional 1 Elementary K-6 (2810)	Teacher - Integrated Math; Teacher - Practical Math
3576797	Fiscus, Kimberly Ann	Instructional HOUSSE Designation Elementary K-6 (2810);Instructional 2 Elementary K-6 (2810);Instructional 2 Ment and/or Phys Handicapped K-12 (9235)	Instructional Coach - Special Education - HS
2375103	Smith, Patricia Marie	Instructional 2 Elementary K-6 (2810);Instructional 2 Reading Specialist PK-12 (7650);Instructional 2 Special Education PK-12 (9225)	Teacher - Algebra II
2692105	Slacktish, Erinn Keelie	Instructional 2 Elementary K-6 (2810);Instructional 2 Mid-Level English 6-9 (2850);Instructional 2 Mid-Level Mathematics 6-9 (2860);Instructional 2 Mid-Level Science 6-9 (2880);Instructional 2 Special Education PK-12 (9225)	Director - Special Education HS
7510523	Mulhollan, Beth Ann	Instructional 2 Elementary K-6 (2810);Instructional 2 Special Education PK-12 (9225)	Teacher - Kindergarten
2394931	Angelo, Shannon Lynn	Instructional 1 Elementary K-6 (2810)	Remedial Specialist - Math - 3rd Grade; Remedial Specialist - Math - 4th Grade; Remedial Specialist - Math - 5th Grade
6581921	Oberholtzer, Stephanie L	Instructional 1 Grades PK-4 (2825)	Teacher - 6th Grade Math
8471928	Kunkel, William D	Instructional 2 Elementary K-6 (2810);Instructional 2 Special Education PK-12 (9225)	Family Coach
7572705	Shaltes, Alison Mislanovich	Instructional 1 Elementary K-6 (2810);Instructional 1 Mid-Level Mathematics 6-9 (2860)	Remedial Specialist - Reading - 6th Grade; Remedial Specialist - Reading - 7th Grade
6128738	Nugent, Emily Elizabeth	Instructional 2 Mid-Level Science 6-9 (2880);Instructional 2 Environmental Educ PK-12 (4820);Instructional 2 Biology 7-12 (8405);Instructional 2 General Science 7-12 (8450)	Teacher - Physical Science
3172707	Paolino, Kimberly A	Instructional 2 Bus-Computer-Info Tech PK-12 (1603);Instructional 2 Mid-Level Mathematics 6-9 (2860);Instructional 2 Biology 7-12 (8405);Instructional 2 General Science 7-12 (8450)	Teacher - Emotional Support - K-8
8529764	Petruzzelli, Dena Marie	Instructional 2 General Science 7-12 (8450)	Teacher - Literary Analysis and Composition I
4740526	Rex, Shelley R	Instructional 2 Elementary K-6 (2810);Instructional 2 Early Childhood N-3 (2840)	Family Coach
7238027	Stabilito, Catherine M	Instructional 2 Elementary K-6 (2810)	Family Coach Lead
7576194	Stump, Shelley A	Private School - Asst or Teacher Nursery/Kindergarten N-K (12833);Instructional 2 Elementary K-6 (2810);Supervisory Supvr Special Education PK-12 (9215);Instructional 2 Ment and/or Phys Handicapped K-12 (9235)	Data Analyst - Special Education

State ID	Employee Name	Areas of Certification Type of Certificate	Grades Teaching or Serving
9515616	Thomas, Christine Wiles	Endorsement Instructional Coach PK-12 (1182);Private School - Asst or Teacher Nursery/Kindergarten N-K (12833);Instructional 1 Elementary K-6 (2810);Instructional 1 Early Childhood N-3 (2840)	Teacher - Transition
5051796	Vasil, Jay J	Instructional 1 Grades PK-4 (2825)	Teacher - Physical Education
6597585	Widdop, Christen Barbara	Instructional 2 Elementary K-6 (2810);Instructional 2 Special Education PK-12 (9225)	Teacher - Learning Support - K-8
4652602	Witman, Morgan Rae	Instructional 1 Elementary K-6 (2810);Instructional 1 Mid-Level Mathematics 6-9 (2860)	Transition Coordinator
9423031	Bruenn, Matthew J	Instructional 1 Elementary K-6 (2810)	Teacher - Earth Science
4983716	Noss, Kelly Anne	Instructional 2 Mid-Level Mathematics 6-9 (2860);Instructional 2 Music PK-12 (7205)	Guidance Counselor - High School
5748249	Gaylord, Callie A	Instructional 1 Reading Specialist PK-12 (7650);Instructional 1 Special Education PK-8 (9226)	Teacher - American Literature; Teacher - Honors American Literature
1907396	Mallon, Regina Marie	Instructional 2 Elementary K-6 (2810);Instructional 2 Ment and/or Phys Handicapped K-12 (9235)	Teacher - Learning Support - K-8
1981528	Nelson, Eileen C	Instructional 1 Grades 4-8 (All subjects 4-6 Math 7-8) (3100)	Guidance Counselor - Elementary School
9302346	Postler, Suzanne	Instructional 1 Grades 4-8 (All subjects 4-6 ELA & Reading (3100);Instructional 1 English 7-12 (3230)	Teacher - 6th Grade Math
8459568	Bonniger, Samantha AnnMyers	Instructional 2 Mid-Level Mathematics 6-9 (2860);Instructional 2 Mid-Level Science 6-9 (2880);Instructional 2 Safety Ed/Driver Ed 7-12 (5215);Instructional 2 Citizenship 7-12 (8825);Instructional 2 Social Studies 7-12 (8875)	Teacher - Transition
5832314	Macuga, Erica Lynn	Instructional 2 Elementary K-6 (2810);Instructional 2 Ment and/or Phys Handicapped K-12 (9235)	Teacher - English Foundations II
2896206	Carver, Jeremy M	Instructional 1 Elementary K-6 (2810);Instructional 1 Early Childhood N-3 (2840);Instructional 1 Special Education PK-12 (9225)	Teacher - Developmental Algebra
5862824	Cramer, Shila Ellyn	Private School - Asst or Teacher Nursery/Kindergarten N-K (12833);Instructional 2 Art PK-12 (1405);Instructional 2 Elementary K-6 (2810);Instructional 2 Early Childhood N-3 (2840)	Teacher - Environmental Science; Teacher - Astronomy
3584764	Jensen, Richard S	Private School - Asst or Teacher Nursery/Kindergarten N-K (12833);Instructional 2 Elementary K-6 (2810);Instructional 2 Reading Specialist PK-12 (7650);Instructional 2 Special Education PK-8 (9226)	Chief Executive Officer
5398423	Nugent, Stephen R	Instructional 2 Elementary K-6 (2810);Instructional 2 Special Education PK-12 (9225)	Professional Learning Coordinator - High School
7047017	Reis, Derick J	Instructional 2 English 7-12 (3230)	Teacher - 5th Grade Social Studies
5452091	Whited, Barron Gene	Instructional 2 Art PK-12 (1405)	Guidance Counselor - High School

State ID	Employee Name	Areas of Certification Type of Certificate	Grades Teaching or Serving
2439473	Barrett, Amy L	Private School - Teacher Elementary Education K-8 (12810);Private School - Asst or Teacher Nursery/Kindergarten N-K (12833);Instructional 2 Elementary K-6 (2810);Instructional 2 Early Childhood N-3 (2840);Instructional 2 Special Education PK-12 (9225)	Teacher - 8th Grade Math
6574183	Davish, Noreen R	Instructional 2 Grades PK-4 (2825);Instructional 2 Grades 4-8 (All subjects 4-6 ELA & Reading (3100);Instructional 2 Reading Specialist PK-12 (7650)	Teacher - Middle School Music
5276125	Waters, Nancy Miriam	Instructional 2 Mid-Level Mathematics 6-9 (2860);Instructional 2 Mid-Level Science 6-9 (2880);Instructional 2 Earth and Space Science 7-12 (8440);Instructional 2 General Science 7-12 (8450)	Teacher - Business Explorations; Teacher - Personal Finance; Teacher - Marketing I
6375062	Tkach, Amber L	Clearance FBI Clearance	Teacher - British and World Literature; Teacher - Honors British and World Literature
1524186	Adams, Rebecca Rose	Instructional 2 Ment and/or Phys Handicapped K-12 (9235)	Instructional Coach - High School - Math
6456018	Zakielarz, Pamela Ashley	Instructional 2 Accounting 7-12 (1610);Instructional 2 Data Processing 7-12 (1625);Instructional 2 Marketing 7-12 (1640);Instructional 2 Office Technologies 7-12 (1658)	Guidance Counselor - High School
8308973	Brohi, Heba H	Private School - Teacher Elementary Education K-8 (12810);Private School - Teacher Soc and Emotionally Dist K-12 (19260);Instructional 2 Elementary K-6 (2810);Instructional 2 Early Childhood N-3 (2840);Instructional HOUSSSE Designation English 7-12 (3230);Instructional HOUSSSE Designation Social Studies 7-12 (8875);Instructional 2 Special Education PK-12 (9225)	Teacher - Algebra I; Teacher - Honors Algebra I
2451951	Kramer, Marc A	Instructional 2 Elementary K-6 (2810);Instructional 2 English 7-12 (3230)	Teacher - Physical Education
6471651	Nickerson Little, Christy Elizabeth	Instructional 2 Elementary K-6 (2810);Instructional 2 Early Childhood N-3 (2840)	Remedial Specialist - Reading - 3rd Grade
6934056	Gussow, Steven M	Instructional 2 English 7-12 (3230)	Teacher - Consumer Math
6402734	Savitz, Lisa K	Instructional 1 Elementary K-6 (2810)	Teacher - Learning Support - HS
7854979	Clark, Susan S	Instructional 2 Elementary K-6 (2810)	Teacher - U.S. and Global Economics; Teacher - Contemporary World Issues
1978748	Walters, Melanie A	Instructional 2 Elementary K-6 (2810);Instructional 2 Special Education PK-12 (9225)	Teacher - Biology
3547971	Humanick, Kymberly Diana	Educational Specialist 1 School Psychologist PK-12 (1875);Instructional 1 Social Studies 7-12 (8875)	Teacher - Learning Support - K-8; Teacher - Life Skills - K-8
8219472	Weikert, Sarah E	Instructional 1 Elementary K-6 (2810);Instructional 1 Special Education PK-12 (9225)	Teacher - 3D Modeling; Teacher - Digital Arts; Teacher - Adobe Illustrator
1764107	Pfeiffer, Eric James	Instructional 2 Elementary K-6 (2810)	Teacher - Earth Science
3562787	Sattler, Emily R	Instructional 2 Elementary K-6 (2810);Instructional 2 Mid-Level Mathematics 6-9 (2860);Instructional 2 Special Education PK-12 (9225)	Teacher - 7th Grade History
1835849	Eckels, Olivia Claire	Instructional 1 English 7-12 (3230)	Teacher - Learning Support - K-8



State ID	Employee Name	Areas of Certification Type of Certificate	Grades Teaching or Serving
4906579	Purdy Hunsberger, Linda	Instructional 2 Elementary K-6 (2810);Instructional 2 Early Childhood N-3 (2840);Instructional 2 Mid-Level Mathematics 6-9 (2860);Instructional 2 Reading Specialist PK-12 (7650)	Teacher - Skills for Health
9252603	Shuttleworth, Stephen A	Instructional 2 English 7-12 (3230);Instructional 2 Reading Specialist PK-12 (7650)	Teacher - World History
8617958	Thomas, Robert John	Instructional 1 Elementary K-6 (2810)	Teacher - Foundations of Art; Teacher - Image Design and Editing
9083653	Williams, Rhonda Shellenberger	Instructional 2 Grades PK-4 (2825);Instructional 2 Special Education PK-8 (9226)	Teacher - Fashion and Interior Design; Teacher - Culinary Arts
1783096	Shaffer, Janelle R	Educational Specialist 1 Elementary School Counselor K-6 (1836);Educational Specialist 1 Secondary School Counselor 7-12 (1837);Instructional 2 Elementary K-6 (2810);Instructional 2 Special Education PK-12 (9225)	Teacher - Life Skills - HS
9571606	Force, Alison Marie	Instructional 1 Mid-Level Mathematics 6-9 (2860);Instructional 1 Mid-Level Science 6-9 (2880);Instructional 1 Mathematics 7-12 (6800);Instructional 1 Biology 7-12 (8405);Instructional 1 General Science 7-12 (8450)	Teacher - U.S. History
9583478	Galonski, Robert B	Instructional 2 Social Studies 7-12 (8875);Instructional 2 Special Education PK-12 (9225)	Teacher - Earth Science; Teacher - Physical Science
2809767	Griffith, Dean A	Instructional 1 Elementary K-6 (2810)	Teacher - 8th Grade History
5420463	Iampietro, Jared A	Instructional 1 Social Studies 7-12 (8875)	Teacher - 7th Grade Science
5026504	Stapf, Laura L	Instructional 1 Citizenship 7-12 (8825)	Teacher - Learning Support - HS
4703501	Burns, Ashley Elizabeth	Instructional 2 Elementary K-6 (2810);Instructional 2 Special Education PK-12 (9225)	Teacher - 7th Grade English Language Arts
8023861	Pittman, Sarah B	Instructional 2 Elementary K-6 (2810);Instructional 2 English 7-12 (3230)	Teacher - Emotional Support - K-8
6798712	Read, Allison Berkowitz	Endorsement Online Instruction Program PK-12 (1184);Instructional 2 Communications 7-12 (3200);Instructional 2 English 7-12 (3230);Program Specialist English as a Second Language (ESL) PK-12 (4499);Instructional 2 Reading Specialist PK-12 (7650)	Teacher - Smart Futures
5349829	Lubich, Luke A	Instructional 2 Grades PK-4 (2825);Instructional 2 Special Education PK-8 (9226)	Teacher - Middle School Health and Physical Educat
6978125	Flinchum, Christina Leah	Endorsement Instructional Coach PK-12 (1182);Instructional 2 Special Education 7-12 (9227)	Teacher - World History; Teacher - Sociology
4103425	Rinaldi, Andrew J	Supervisory Supvr Special Education PK-12 (9215);Instructional 2 Ment and/or Phys Handicapped K-12 (9235)	Teacher - Foundations of Music
9481531	Learn, Ryan P	Instructional 2 Elementary K-6 (2810);Instructional 2 Special Education PK-12 (9225)	Guidance Counselor - High School
5897815	Froehlich, Brittany P	Instructional 2 Elementary K-6 (2810);Instructional 2 Reading Specialist PK-12 (7650)	Teacher - Learning Support - K-8

State ID	Employee Name	Areas of Certification Type of Certificate	Grades Teaching or Serving
1738672	Scheirer, Michael J	Instructional 2 Grades PK-4 (2825);Instructional 2 Reading Specialist PK-12 (7650);Instructional 2 Special Education PK-8 (9226);Instructional 1 Special Education Expansion 7-12 (9229)	Instructional Coach - High School - Social Studies
7083191	Smith, Joseph Bart	Instructional 2 Social Studies 7-12 (8875)	Teacher - Biology
7358162	Walsh, Mary Elise	Instructional 1 Elementary K-6 (2810);Instructional 1 Special Education PK-12 (9225)	Teacher - Literary Analysis and Composition I
6813572	Altman, Dorry Ann	Administrative 1 Secondary Principal 7-12 (1105);Instructional 2 Mid-Level Mathematics 6-9 (2860);Supervisory 1 Supvr Science 7-12 (8415);Instructional 2 General Science 7-12 (8450)	Teacher - 7th Grade English Language Arts
4686739	Gibbons, Ahrin Yvette	Instructional 1 Mathematics 7-12 (6800);Instructional 1 General Science 7-12 (8450);Instructional 1 Physics 7-12 (8470)	Teacher - 8th Grade Science
6410953	Olsavsky, Michelle Lenore	Supervisory Supvr Curriculum & Inst PK-12 (2915);Instructional 2 Social Studies 7-12 (8875)	Instructional Coach - Special Education - HS
1741679	Shea, Amy M	Instructional 1 Grades PK-4 (2825);Instructional 1 Special Education PK-8 (9226)	Guidance Counselor - High School
8451679	Oakes, Casey Louise	Instructional 2 Early Childhood N-3 (2840);Instructional 2 Special Education PK-12 (9225)	Teacher - 6th Grade Math
8784304	Krol, Nicole S	Instructional 2 Elementary K-6 (2810);Instructional 2 Special Education PK-12 (9225)	Teacher - Life Skills - HS
2349318	Devine Owen, Erin L	Letter of Equivalency 1 Master's Equivalency - (1185);Instructional 2 Grades PK-4 (2825);Instructional 2 Grades 4-8 (All subjects 4-6 ELA & Reading (3100);Instructional 2 Grades 4-8 (All subjects 4-6 Science 7-8) (3100)	Supervisor of Student Health Services
8947683	Abul Ela, Christina C	Administrative 1 Principal PK-12 (1115);Instructional 2 Mid-Level Mathematics 6-9 (2860);Instructional 2 Communications 7-12 (3200);Instructional 2 English 7-12 (3230);Instructional 2 Special Education PK-12 (9225)	Teacher - AP Chemistry; Teacher - Honors Chemistry
9413189	Acland, Kathrine Rita	Instructional 2 Elementary K-6 (2810);Instructional 2 Mid-Level English 6-9 (2850);Instructional 2 Special Education PK-12 (9225)	Teacher - Consumer Math
7327629	Alderson, Jordan M	Endorsement Autism PK-12 (1180);Instructional 2 Elementary K-6 (2810);Program Specialist English as a Second Language (ESL) PK-12 (4499);Instructional 2 Special Education PK-8 (9226)	Teacher - Honors Literary Analysis & Composition 2; Teacher - Literary Analysis and Composition II
3695945	Baker, Andrea Marie	Instructional 2 Elementary K-6 (2810);Instructional 2 Special Education PK-12 (9225)	Family Coach
8071286	Barger, Tammy M	Instructional 2 Elementary K-6 (2810)	Teacher - 7th Grade Science
5358072	Boyer, Cathy Marie	Instructional 1 Elementary K-6 (2810)	Teacher - Developmental Algebra
1302864	Boyer, Jessica Leigh	Endorsement Instructional Coach PK-12 (1182);Instructional 2 Elementary K-6 (2810);Instructional 2 English 7-12 (3230);Instructional 2 Reading Specialist PK-12 (7650)	Teacher - 2nd Grade; Teacher - 3rd Grade Math; Teacher - 4th Grade Math; Teacher - 5th Grade Math

State ID	Employee Name	Areas of Certification Type of Certificate	Grades Teaching or Serving
1524281	Camaioni, Nicole	Private School - Teacher Biology: Sec. Ed. 9-12 (18405);Instructional 2 Biology 7-12 (8405);Instructional 2 General Science 7-12 (8450)	Teacher - AP Macroeconomics; Teacher - AP Microeconomics; Teacher - Modern World Studies
8343935	Logan, Laura Jean	Instructional 2 Grades PK-4 (2825);Instructional 2 Grades 5-6 (2826);Instructional 2 Special Education PK-8 (9226)	Teacher - 2nd Grade
5045706	Congdon, Rebekah Lynne	Private School - Asst or Teacher Nursery/Kindergarten N-K (12833);Instructional 2 Elementary K-6 (2810);Instructional 2 Special Education PK-12 (9225)	Teacher - Learning Support - HS
7931508	Cragle, Caleb James	Private School - Teacher Soc and Emotionally Dist K-12 (19260);Instructional 2 Special Education PK-12 (9225)	Data Analyst
4096064	Dietrich, Jenna Lee	Instructional 2 English 7-12 (3230)	Teacher - Learning Support - K-8
5301637	George, Michelle Beatrice	Instructional 2 Elementary K-6 (2810)	Family Coach Lead
4529215	Girard, Karen Danielle	Instructional 1 Elementary K-6 (2810)	Teacher - 2nd Grade; Teacher - 3rd Grade Science; Teacher - 4th Grade Science; Teacher - 5th Grade Science
1020343	Goughnour, Lauren Marie	Instructional 1 General Science 7-12 (8450)	Teacher - Algebra I
1563801	Guyer, Melissa Miller	Educational Specialist 2 School Psychologist PK-12 (1875);Instructional 1 Elementary K-6 (2810)	Teacher - Substitute - Special Education - HS
1813936	Hagelgans, Matthew J	Administrative 1 Principal PK-12 (1115);Supervisory 1 Supvr Curriculum & Inst PK-12 (2915);Instructional 2 Communications 7-12 (3200);Instructional 2 English 7-12 (3230)	Teacher - 7th Grade History
7142391	Hathaway, Melanie Lynn	Instructional 2 Elementary K-6 (2810);Instructional 2 Ment and/or Phys Handicapped K-12 (9235)	Teacher - 6th Grade English Language Arts
1089065	Heard, Pamela Ann	Instructional 1 English 7-12 (3230);Instructional 1 Social Studies 7-12 (8875)	Teacher - Drivers Safety
1463905	Hill, Jessica Ann	Instructional 2 Mathematics 7-12 (6800)	Teacher - 6th Grade Science
4386179	McCarthy, Valerie Lynn	Instructional 1 Grades PK-4 (2825);Instructional 1 Special Education PK-8 (9226);Instructional 1 Special Education Expansion 7-12 (9229)	Teacher - 6th Grade History
9127352	Keefe, Allison A	Endorsement Instructional Coach PK-12 (1182);Instructional 2 Elementary K-6 (2810)	Teacher - 7th Grade English Language Arts
7041968	Kelso, Sharon A	Educational Specialist 1 Elem. & Secondary School Counselor PK-12 (1839)	Teacher - Honors Literary Analysis & Composition 2; Teacher - Literary Analysis and Composition II
3965932	Kreseski, Kimberly Ann	Instructional 2 General Science 7-12 (8450);Instructional 2 Social Studies 7-12 (8875)	Remedial Specialist - Reading - 6th Grade; Remedial Specialist - Reading - 7th Grade
1826952	Kroner, Lewis F	Instructional 1 Art PK-12 (1405)	Teacher - Foundations of Music
9014616	Klein, Suzanne Elizabeth	Instructional 1 Grades PK-4 (2825);Instructional 1 Family-Consumer Sci PK-12 (5600);Instructional 1 Special Education PK-8 (9226);Instructional 1 Special Education 7-12 (9227)	Guidance Counselor - Elementary School
2156432	Webb, Alexandra L	Instructional 2 Mathematics 7-12 (6800)	Teacher - 7th Grade Math

State ID	Employee Name	Areas of Certification Type of Certificate	Grades Teaching or Serving
9635647	Lee, Erica Marie	Instructional 2 Bus-Computer-Info Tech PK-12 (1603);Instructional 2 Social Studies 7-12 (8875)	Guidance Counselor - High School
6850415	Lepsch, Anna E	Instructional 1 Social Studies 7-12 (8875)	Instructional Coach - Special Education - K-8
1960576	Lesczynski, Trisa Ann	Endorsement Instructional Coach PK-12 (1182);Instructional 2 Elementary K-6 (2810);Instructional 2 Special Education PK-12 (9225)	Teacher - Early Childhood Education; Teacher - Hospitality and Tourism
9457194	Mack, Cathryn L	Instructional 2 Elementary K-6 (2810);Instructional 2 Mid-Level Mathematics 6-9 (2860)	Teacher - Life Skills - K-8; Teacher - Multi-Disabilities - K-8
7621747	Maio, Pamela	Instructional 1 Elementary K-6 (2810);Instructional 1 Grades PK-4 (2825);Instructional 1 Special Education PK-8 (9226)	Teacher - American Literature
5936782	Laubach, Elena	Instructional 2 Elementary K-6 (2810);Instructional 2 Mid-Level English 6-9 (2850)	Guidance Counselor - High School
7151362	McKeown, Janelle Lee	Instructional 1 Biology 7-12 (8405)	Teacher - Honors Literary Analysis & Composition I; Teacher - Literary Analysis and Composition I
8037085	McLaughlin, Kimberly Renee	Instructional 1 Grades PK-4 (2825);Instructional 1 Special Education PK-8 (9226)	Enrollment Specialist
4136507	McAndrew, Kate Louise	Administrative 1 Principal PK-12 (1115);Instructional 2 English 7-12 (3230)	Teacher - Earth Science
7875193	Jafarian, Mia N	Instructional 2 Elementary K-6 (2810);Instructional 2 Special Education PK-8 (9226)	Guidance Counselor - High School
5474958	O Neill, Carolyn J	Instructional 2 Elementary K-6 (2810);Instructional 2 Mid-Level Mathematics 6-9 (2860);Instructional 2 Reading Specialist PK-12 (7650)	Remedial Specialist - Reading - 1st Grade; Remedial Specialist - Reading - 2nd Grade; Remedial Specialist - Reading - Kindergarten
4021413	Parkes-Mattox, Gemma M	Instructional 2 Elementary K-6 (2810);Instructional 2 Mid-Level English 6-9 (2850);Instructional 2 Mid-Level Mathematics 6-9 (2860);Program Specialist English as a Second Language (ESL) PK-12 (4499)	Teacher - Autistic Support - HS
1207939	Rau, Sarah Elizabeth	Instructional 2 Elementary K-6 (2810)	Teacher - Biology
6297524	Schall, Danielle Marie	Educational Specialist 1 Inst Technology Specialist PK-12 (1825);Instructional 2 Elementary K-6 (2810);Instructional 2 Early Childhood N-3 (2840);Instructional 2 Family-Consumer Sci PK-12 (5600);Instructional 2 Special Education PK-8 (9226)	Assistant Director - Special Education - HS
6546756	Schmidt, Ashley Brooke	Administrative Principal PK-12 (1115);Instructional 2 Art PK-12 (1405)	Teacher - Learning Support - K-8
9038206	Schwartz, Olivia Marie	Letter of Equivalency Master's Equivalency - (1185);Instructional 2 Health & Physical Educ PK-12 (4805);Instructional 2 Safety Ed/Driver Ed 7-12 (5215)	Teacher - Kindergarten
2496286	Schweizer, Cara Marie	Instructional 2 Mathematics 7-12 (6800)	Teacher - Earth Science; Teacher - Honors Earth Science
2391473	Shivetts, Stephanie Lynn	Instructional 1 Grades PK-4 (2825);Instructional 1 Special Education PK-8 (9226)	Guidance Counselor - Elementary School
4757876	Kowalok, Krista Marie	Instructional 1 Spanish PK-12 (4490)	Teacher - 4th Grade Science
3835272	Smith, Ashley R	Instructional 2 Social Studies 7-12 (8875)	Teacher - 6th Grade Science

State ID	Employee Name	Areas of Certification Type of Certificate	Grades Teaching or Serving
3971083	Sonlin, Allison Mott	Administrative 1 Principal PK-12 (1115);Instructional 2 English 7-12 (3230);Instructional 2 Special Education PK-12 (9225)	Teacher - American Literature
4316015	Strong, Kimberly	Instructional 2 Elementary K-6 (2810);Instructional 2 Early Childhood N-3 (2840);Instructional 2 Reading Specialist PK-12 (7650)	Teacher - 5th Grade Math
2873471	Nicholas, Fallon Nicole	Instructional 2 English 7-12 (3230);Instructional 2 Social Studies 7-12 (8875);Instructional 2 Special Education PK-12 (9225)	Guidance Counselor - Middle School
1248284	Wesley, Mindy C	Administrative 1 Principal PK-12 (1115);Instructional 1 Reading Specialist PK-12 (7650);Instructional 1 Special Education PK-12 (9225)	Enrollment Specialist
5847123	Wright, Kathleen Ann	Instructional 1 Library Science PK-12 (6420)	Instructional Coach - General Education - Elementa
2916741	Zeisloft, Roxanne Bogo	Instructional 2 Environmental Educ PK-12 (4820);Instructional 2 Biology 7-12 (8405)	Guidance Counselor - High School
7867191	Andrews, Lori Ann	Instructional 1 Grades PK-4 (2825);Instructional 1 Grades 4-8 (All subjects 4-6 ELA & Reading (3100);Instructional 1 Special Education PK-8 (9226)	Teacher - Accounting; Teacher - AP Calculus AB; Teacher - Calculus
8767092	Gruber, Jenna Bertele	Instructional 2 Elementary K-6 (2810);Instructional 2 Special Education PK-12 (9225)	Teacher - Middle School Art
6059381	Boisvert, Jill	Instructional 2 Reading Specialist PK-12 (7650);Instructional 2 Special Education PK-12 (9225)	Teacher - Geometry
6282358	Creaven, Melissa	Instructional 2 Elementary K-6 (2810);Instructional 2 Reading Specialist PK-12 (7650)	Teacher - 3rd Grade Science
6716134	Dillon, Anne	Administrative 2 Principal PK-12 (1115);Instructional 2 Elementary K-6 (2810);Supervisory Supvr Curriculum & Inst PK-12 (2915)	Teacher - 8th Grade English Language Arts
8536742	McNulty, Corey Thomas	Instructional 2 Elementary K-6 (2810);Program Specialist English as a Second Language (ESL) PK-12 (4499)	Teacher - 7th Grade History
7014575	Sarber, Kenneth Ogden	Instructional 1 Grades PK-4 (2825)	Teacher - 8th Grade Math
8984271	Barrios, Jennifer A	Instructional 2 Elementary K-6 (2810);Instructional 2 Mid-Level English 6-9 (2850);Instructional 2 Mid-Level Citiz. Ed 6-9 (2870)	School Social Worker
8302961	Broniszewski, Diane	Instructional 2 Elementary K-6 (2810);Instructional 2 Mid-Level English 6-9 (2850);Instructional 2 Mid-Level Mathematics 6-9 (2860)	Teacher - French
7462653	Lipiec, Susan E	Instructional 2 Elementary K-6 (2810)	Teacher - Learning Support - K-8
8925806	Feeney Hoffmaster, Shannon Margaret	Instructional 2 Elementary K-6 (2810);Instructional 2 Mid-Level Mathematics 6-9 (2860);Instructional 2 Special Education PK-12 (9225)	Teacher - Learning Support - HS
7984937	Alcott, Elyse M	Instructional 2 Elementary K-6 (2810);Program Specialist English as a Second Language (ESL) PK-12 (4499);Instructional 2 Special Education PK-12 (9225)	Teacher - 2nd Grade
1786193	Natale, Valerie L	Instructional 2 Elementary K-6 (2810);Instructional 2 Special Education PK-12 (9225)	Assistant Director - Special Education - HS
1391528	Pelissier, Michelle	Instructional 1 Elementary K-6 (2810)	Teacher - Learning Support - K-8; Teacher - Life Skills - K-8
4810264	Riggs, John	Instructional 2 Biology 7-12 (8405)	Teacher - British and World Literature

State ID	Employee Name	Areas of Certification Type of Certificate	Grades Teaching or Serving
1534506	Stanforth, Melanie	Letter of Equivalency Master's Equivalency - (1185);Instructional 2 Elementary K-6 (2810);Instructional 2 Ment and/or Phys Handicapped K-12 (9235)	Speech Pathologist
6501895	Pease, Kelly Ann	Administrative Principal PK-12 (1115);Instructional 2 French PK-12 (4410)	Teacher - Literary Analysis and Composition I
2596726	Lynn, Sharon	Instructional 2 Elementary K-6 (2810);Instructional 2 Ment and/or Phys Handicapped K-12 (9235)	Teacher - Drivers Safety
2382481	Walker, Tara M	Instructional 1 Elementary K-6 (2810)	Teacher - Learning Support - HS
8905083	Pastin, Laurie Lynn	Educational Specialist 2 Secondary School Counselor 7-12 (1837)	Teacher - 7th Grade Math
5902961	Zanetti, Holli Ann	Administrative 2 Principal PK-12 (1115);Instructional 2 Social Studies 7-12 (8875)	Remedial Specialist - Reading - 1st Grade; Remedial Specialist - Reading - 2nd Grade; Remedial Specialist - Reading - Kindergarten
1736945	Marshall, Casey Marie	Instructional 2 Elementary K-6 (2810);Instructional 2 Spanish PK-12 (4490)	Teacher - 4th Grade Math
4590197	Barnhart, Jessica Maria	Administrative 1 Principal PK-12 (1115);Instructional 2 Elementary K-6 (2810);Supervisory Supvr Special Education PK-12 (9215);Instructional 2 Special Education PK-12 (9225)	Teacher - Learning Support - K-8
1305876	Tainter, Erin F	Instructional 2 Elementary K-6 (2810);Instructional 2 Early Childhood N-3 (2840);Instructional 2 Mid-Level English 6-9 (2850);Instructional 2 Mid-Level Mathematics 6-9 (2860)	Teacher - 7th Grade Science
8349429	Sinan, Megan C	Instructional 2 Elementary K-6 (2810);Instructional 2 English 7-12 (3230);Instructional 2 Special Education PK-12 (9225)	Teacher - Culinary Arts
4609487	Geiman, Amanda Mae	Instructional 2 Elementary K-6 (2810);Instructional 2 English 7-12 (3230);Instructional 2 Special Education PK-12 (9225)	Teacher - 2nd Grade
6052425	McCullough, Kelly S	Instructional 1 Art PK-12 (1405)	Teacher - 7th Grade History; Teacher - Earth Science
5493409	Monterroso, Jacqueline Jay	Instructional 1 Early Childhood N-3 (2840);Instructional 1 Special Education PK-8 (9226);Instructional 1 Special Education Expansion 7-12 (9229)	Teacher - 7th Grade History
6364271	Cox, Brianne	Instructional 2 Elementary K-6 (2810)	Teacher - Algebra I
6512461	Bartuska, Rebecca Sowa	Instructional 2 Mid-Level Science 6-9 (2880);Instructional 2 Chemistry 7-12 (8420)	Teacher - 8th Grade Science
6739749	Cashman, Sandy	Instructional 2 Grades PK-4 (2825);Instructional 2 Special Education PK-8 (9226);Instructional 1 Special Education 7-12 (9227)	Family Coach
2079054	Hetrick, Angela Mae	Instructional 2 Elementary K-6 (2810)	Teacher - Sociology
6017637	Deloe, Anita J	Instructional 2 Biology 7-12 (8405);Instructional 2 Chemistry 7-12 (8420);Instructional 2 Physics 7-12 (8470)	Teacher - Criminology; Teacher - Anthropology; Teacher - Law and Order
8209824	Harlan, Maria	Instructional 1 English 7-12 (3230)	Teacher - Life Skills - K-8
4157347	Sheffo, Arlene	Instructional 2 English 7-12 (3230)	Teacher - 7th Grade Math
6208696	Hill, Ocie	Instructional 2 Elementary K-6 (2810);Instructional 2 Special Education PK-12 (9225)	Teacher - Geography and World Cultures; Teacher - AP U.S. History; Teacher - World History

State ID	Employee Name	Areas of Certification Type of Certificate	Grades Teaching or Serving
6185328	Mahon, Jill	Instructional 2 Biology 7-12 (8405);Instructional 2 Special Education PK-12 (9225)	Teacher - 4th Grade English Language Arts
5782691	Miller, Samantha	Administrative 1 Principal PK-12 (1115);Private School - Teacher French K-12 (14410);Supervisory Supvr Curriculum & Inst PK-12 (2915);Instructional 2 English 7-12 (3230);Instructional 2 French PK-12 (4410)	Teacher - British and World Literature
8186069	Nicholas, Jesse	Educational Specialist 1 Secondary School Counselor 7-12 (1837);Instructional 2 Mid-Level Mathematics 6-9 (2860);Instructional 2 Special Education PK-12 (9225)	Teacher - AP World History; Teacher - World History
6041706	Reimers, Nancy	Instructional 2 Ment and/or Phys Handicapped K-12 (9235)	Teacher - Learning Support - HS
2856539	Mruskovic, Brenna Colleen	Instructional 2 Elementary K-6 (2810);Instructional 2 Early Childhood N-3 (2840)	Teacher - 8th Grade History
5458473	Shonberg, Cynthia Lee	Instructional 2 Elementary K-6 (2810);Instructional 2 Special Education PK-12 (9225)	Teacher - Medical Terminology; Teacher - AP Environmental Science; Teacher - Anatomy & Physiology
1917905	Wilson, Lauren	Instructional 2 English 7-12 (3230)	Literacy Coordinator
9870941	Berkey, Daniel W	Instructional 1 English 7-12 (3230)	Teacher - Algebra I
3102191	Worrell, Kimberly A	Instructional 1 Special Education PK-12 (9225)	Teacher - Continuing Algebra
6139372	Jackson, Veronica A	Instructional 2 Elementary K-6 (2810);Instructional 2 Special Education PK-12 (9225)	Teacher - Learning Support - HS
8090325	Ciarlone, Shannon	Instructional 2 Mid-Level Mathematics 6-9 (2860);Instructional 2 Mid-Level Science 6-9 (2880);Instructional 2 Environmental Educ PK-12 (4820);Instructional 2 Biology 7-12 (8405);Instructional 2 General Science 7-12 (8450);Instructional 2 Physics 7-12 (8470)	Teacher - 1st Grade
8328516	Ambrose, Danielle	Educational Specialist 1 Inst Technology Specialist PK-12 (1825);Instructional 1 English 7-12 (3230);Instructional 1 Social Studies 7-12 (8875)	Guidance Counselor - High School
1846798	Johnson-Nied, Caitlin	Educational Specialist 2 Elementary School Counselor K-6 (1836);Educational Specialist 2 Secondary School Counselor 7-12 (1837)	Teacher - 4th Grade Science
8713091	Kieffer, Brittany E	Instructional 2 Elementary K-6 (2810)	Enrollment Specialist
8258565	Kennedy, Sabrina C	Letter of Equivalency Master's Equivalency - (1185);Instructional 2 Elementary K-6 (2810);Instructional 2 Ment and/or Phys Handicapped K-12 (9235)	Teacher - Emotional Support - HS
4706023	Coyne, Heather Marie	Administrative Principal PK-12 (1115);Instructional 2 Elementary K-6 (2810)	Teacher - Physical Science
7276961	Rosenberger, Shauna	Instructional 2 Health & Physical Educ PK-12 (4805);Instructional 2 Safety Ed/Driver Ed 7-12 (5215)	Teacher - 6th Grade History
5140418	Christmas, Stacy D	Administrative 1 Principal PK-12 (1115);Instructional 2 Grades PK-4 (2825)	Teacher - 6th Grade Math; Remedial Specialist - Math - 6th Grade
7372015	Martin, Jennifer B	Instructional 2 Mid-Level Mathematics 6-9 (2860);Instructional 2 Mid-Level Science 6-9 (2880);Instructional 2 Music PK-12 (7205)	Teacher - Spanish

State ID	Employee Name	Areas of Certification Type of Certificate	Grades Teaching or Serving
3408636	Harris, Tracy E	Instructional 2 Mid-Level English 6-9 (2850);Instructional 2 Ment and/or Phys Handicapped K-12 (9235)	Remedial Specialist - Reading - 6th Grade; Remedial Specialist - Reading - 8th Grade
8578416	Evangelista, Gina A	Instructional 2 Elementary K-6 (2810);Instructional 2 Mid-Level English 6-9 (2850);Instructional 2 Mid-Level Mathematics 6-9 (2860);Instructional 2 Mid-Level Citiz. Ed 6-9 (2870);Program Specialist English as a Second Language (ESL) PK-12 (4499)	Remedial Specialist - Reading - High School
7820563	Taylor, Laura Ellen	Instructional 1 Mathematics 7-12 (6800)	Teacher - 6th Grade Science
5964816	Houseknecht, Dayna S	Instructional 2 Chemistry 7-12 (8420)	Teacher - 8th Grade English Language Arts
7601878	MacLacklin, Tovah I	Educational Specialist 1 Elem. & Secondary School Counselor PK-12 (1839);Instructional 1 Social Studies 7-12 (8875)	Teacher - Literary Analysis and Composition I
7145246	Anderson, Aisha N	Instructional 1 Elementary K-6 (2810);Instructional 1 Special Education PK-12 (9225)	Teacher - American Literature; Teacher - AP English Literature and Composition
3526216	Tybl, Mary Susan	Instructional 2 Elementary K-6 (2810);Instructional 2 Special Education PK-8 (9226)	Teacher - Geometry; Teacher - Honors Geometry
5674767	Radico, Lauren N	Instructional 2 Elementary K-6 (2810)	Teacher - Learning Support - HS
4101806	Morgan, Taryn D	Instructional 2 Social Studies 7-12 (8875);Instructional 2 Special Education 7-12 (9227)	Teacher - Introduction to Agriscience; Teacher - Veterinary Science; Teacher - Green Design and Technology
9453767	Donnelly, Maureen J	Instructional 2 Elementary K-6 (2810);Instructional 2 Reading Specialist PK-12 (7650)	Teacher - Developmental Algebra
8359342	Stump, Melissa C	Instructional 2 Bus-Computer-Info Tech PK-12 (1603);Instructional 2 Elementary K-6 (2810);Instructional 2 Mid-Level Mathematics 6-9 (2860)	Teacher - Emotional Support - HS
5172808	Lombardo, Jaime L	Educational Specialist 2 Secondary School Counselor 7-12 (1837)	Teacher - American Literature
7681605	Clagett, David C	Instructional 2 Elementary K-6 (2810);Instructional 2 English 7-12 (3230)	Teacher - U.S. History
3045108	Smyntek, Michael A	Instructional 2 Elementary K-6 (2810)	Teacher - 8th Grade History
8908467	Barney, Christine J	Educational Specialist 2 Secondary School Counselor 7-12 (1837);Educational Specialist 2 Elem. & Secondary School Counselor PK-12 (1839)	Teacher - World History
9463507	Tumas, John P	Educational Specialist 2 Secondary School Counselor 7-12 (1837)	Teacher - Honors U.S. History
9759372	Dannaker, Doris	Instructional 1 Bus-Computer-Info Tech PK-12 (1603);Instructional 1 Family-Consumer Sci PK-12 (5600)	Remedial Specialist - Math - 7th Grade; Remedial Specialist - Math - 8th Grade
5204709	Weisz, Christopher Joseph	Instructional 2 Bus-Computer-Info Tech PK-12 (1603);Instructional 2 Marketing (Distributive) Ed PK-12 (1666);Instructional 2 Mathematics 7-12 (6800);Instructional 2 Special Education PK-12 (9225)	Teacher - U.S. History
8269473	Stalebrink, Meghan D	Instructional 1 English 7-12 (3230);Instructional 1 Mathematics 7-12 (6800)	Teacher - Honors Literary Analysis & Composition I; Teacher - Literary Analysis and Composition I



State ID	Employee Name	Areas of Certification Type of Certificate	Grades Teaching or Serving
8725829	Zollman, Jennifer L	Endorsement 1 Instructional Coach PK-12 (1182);Instructional 2 Elementary K-6 (2810);Instructional 2 Mid-Level English 6-9 (2850);Instructional 2 Mid-Level Citiz. Ed 6-9 (2870);Instructional 2 Mid-Level Science 6-9 (2880);Instructional 2 Social Studies 7-12 (8875);Instructional 2 Special Education PK-12 (9225)	Teacher - Learning Support - HS
4819124	McIvor, Ashley N	Instructional 2 Elementary K-6 (2810);Instructional 2 Family-Consumer Sci PK-12 (5600)	Certified School Nurse
7359613	Hartman, Robin E	Instructional 2 Elementary K-6 (2810);Instructional 2 Reading Specialist PK-12 (7650)	Professional Learning Coordinator - Elementary
5978469	Berry, Sharon M	Instructional 1 Elementary K-6 (2810);Instructional 1 Special Education PK-12 (9225)	Teacher - Algebra II
6946217	Saad, Tammy L	Administrative 1 Principal PK-12 (1115);Instructional 2 Elementary K-6 (2810);Instructional 2 Special Education PK-12 (9225)	Teacher - 1st Grade
8947597	Kenzakowski, Rebecca A	Instructional 2 Elementary K-6 (2810);Instructional 2 English 7-12 (3230);Instructional 2 Social Studies 7-12 (8875)	Teacher - Biology
3031084	Galonski, Morgan M	Instructional 1 Grades PK-4 (2825)	Remedial Specialist - Reading - High School
7290536	Shaffer, Jamie D	Instructional 1 English 7-12 (3230)	Teacher - 3rd Grade English Language Arts
9427584	Mueller, Antoinette L	Instructional 2 Mathematics 7-12 (6800)	Remedial Specialist - Reading - High School
2707503	Laudenslager, Leslie J	Instructional 1 Grades PK-4 (2825);Instructional 1 Special Education PK-8 (9226)	Teacher - 8th Grade English Language Arts
5473073	McGinty, Jennifer Nicole	Instructional 1 Grades PK-4 (2825);Instructional 1 Special Education PK-8 (9226)	Enrollment Specialist
2784396	Velto, Rachel Andrea	Instructional 2 Special Education PK-12 (9225)	Teacher - Spanish
4237836	Love, Roberta M	Instructional 2 Elementary K-6 (2810);Instructional 2 Mid-Level English 6-9 (2850)	Teacher - 6th Grade History
6105673	O Reilly, Jaclyn E	Instructional 2 Health & Physical Educ PK-12 (4805)	MTSS Coordinator - High School
6532305	Kiger, Darian N	Instructional 1 English 7-12 (3230);Supervisory Supvr Special Education PK-12 (9215);Instructional 1 Special Education PK-12 (9225)	Teacher - Literary Analysis and Composition I
7020427	Shehan, Amy M	Instructional 1 Elementary K-6 (2810);Instructional 1 English 7-12 (3230)	Guidance Counselor - Middle School
9589157	Giordano, Kathryn	Instructional 2 Mid-Level Science 6-9 (2880);Instructional 2 Biology 7-12 (8405)	School Psychologist
1787689	Young, Karenann S	Instructional 2 Elementary K-6 (2810)	Chief Operations Officer
7461641	Hornbake, Jansen L	Instructional 2 Family-Consumer Sci PK-12 (5600);Instructional 2 Social Studies 7-12 (8875)	Principal - Elementary School
2169428	Kozar, Bridget M	Instructional 2 Bus-Computer-Info Tech PK-12 (1603)	Principal - Middle School
9764135	Donovan, James M	Instructional 2 Bus-Computer-Info Tech PK-12 (1603);Instructional 2 Safety Ed/Driver Ed 7-12 (5215);Instructional 2 Mathematics 7-12 (6800);Instructional 2 Special Education PK-12 (9225)	Director - Finance
4580689	Montgomery, James W	Instructional 2 Ment and/or Phys Handicapped K-12 (9235)	Assistant Principal - Elementary School

State ID	Employee Name	Areas of Certification Type of Certificate	Grades Teaching or Serving
6873915	Svonavec, Lauren J	Instructional 1 Elementary K-6 (2810);Instructional 1 Early Childhood N-3 (2840);Instructional 1 Mid-Level English 6-9 (2850)	Teacher - Learning Support - K-8
7147327	Abel, Keri A	Instructional 2 English 7-12 (3230)	Teacher - 6th Grade Science
8981801	Capitano, Jesse C	Instructional 2 Elementary K-6 (2810)	Instructional Coach - Special Education - HS
4018743	Dumas, Jennifer A	Instructional 1 Elementary K-6 (2810)	Teacher - Computer Science; Teacher - Computer Literacy
9089175	Lelko, Susan R	Instructional 2 Elementary K-6 (2810);Instructional 2 Mid-Level Citiz. Ed 6-9 (2870);Instructional 2 Reading Specialist PK-12 (7650);Instructional 2 Special Education PK-12 (9225)	Teacher - Learning Support - HS
8105219	Fiscus, Grace A	Instructional 2 Elementary K-6 (2810);Instructional 2 Mid-Level Mathematics 6-9 (2860)	Teacher - Kindergarten
5325374	Pacolay, Dana R	Instructional 1 Grades PK-4 (2825)	Teacher - Learning Support - HS
2918687	Manko, Laura C	Educational Specialist 2 Secondary School Counselor 7-12 (1837);Supervisory Supvr Pupil Personnel Serv PK-12 (2930)	Guidance Counselor - High School
9674013	Skelly, Cortney Marie	Instructional 1 Elementary K-6 (2810);Instructional 1 Special Education PK-8 (9226)	Teacher - Learning Support - K-8
1658035	Staley, Ashly D	Instructional 1 Elementary K-6 (2810);Instructional 1 Special Education PK-12 (9225)	Teacher - American Literature
2749242	Hale-Patterson, Melissa P	Instructional 1 Mathematics 7-12 (6800)	Instructional Coach - Special Education - K-8
7465013	Nicol, Ericka Samuels	Instructional 2 Social Studies 7-12 (8875)	Teacher - AP Biology; Teacher - Earth Science
5415083	Thompson, Jennifer M	Instructional 2 Elementary K-6 (2810)	Teacher - 2nd Grade; Teacher - 3rd Grade Social Studies; Teacher - 4th Grade Social Studies; Teacher - 5th Grade Social Studies
1850535	Witmer, Lauren G	Instructional 2 Mathematics 7-12 (6800)	Teacher - 5th Grade English Language Arts
5436107	Klara, Michelle A	Endorsement Online Instruction Program PK-12 (1184);Instructional 1 Social Studies 7-12 (8875);Instructional 1 Special Education 7-12 (9227)	Teacher - 6th Grade English Language Arts; Teacher - 8th Grade Science
6326159	Moritz, Kristel D	Instructional 1 Elementary K-6 (2810);Instructional 1 Reading Specialist PK-12 (7650)	Certified School Nurse
2429204	Patrick, Agatha A	Instructional 1 Elementary K-6 (2810)	Teacher - Literary Analysis and Composition I
7012802	Seraut Schlager, Lauren Jannine	Instructional 1 Grades PK-4 (2825);Instructional 1 Special Education PK-8 (9226)	Teacher - Middle School Health and Physical Educat
9891649	Reamer, Brittany Nicole	Instructional 2 Earth and Space Science 7-12 (8440);Instructional 2 General Science 7-12 (8450)	Teacher - Emotional Support - K-8
5869452	Langer, Shannon E	Educational Specialist 2 School Nurse PK-12 (1890)	Teacher - 4th Grade English Language Arts
2153019	Ryan, Elizabeth B	Instructional 2 Elementary K-6 (2810)	Teacher - Geometry
4049892	Horton, Danielle R	Instructional 1 Elementary K-6 (2810);Instructional 1 Early Childhood N-3 (2840)	Teacher - Computer Literacy; Teacher - Game Design

State ID	Employee Name	Areas of Certification Type of Certificate	Grades Teaching or Serving
9387058	Hartlep, Tara R	Instructional 2 Elementary K-6 (2810);Instructional 2 Family-Consumer Sci PK-12 (5600)	Teacher - 6th Grade English Language Arts
8347132	Baranoski, Anna M	Instructional 1 Elementary K-6 (2810)	Teacher - Learning Support - K-8
2141631	Brown, Sarah C	Administrative 2 Principal PK-12 (1115);Instructional 2 Mid-Level English 6-9 (2850);Supervisory Supvr Curriculum & Inst PK-12 (2915);Instructional 2 Ment and/or Phys Handicapped K-12 (9235)	Teacher - Physical Science
9456021	Jackson, Erin L	Instructional 2 Music PK-12 (7205)	Teacher - French
2705827	Lucia, Jennifer A	Instructional 1 Biology 7-12 (8405);Instructional 1 Earth and Space Science 7-12 (8440)	Assistant Director - Special Education - K-8
9069282	Lynn, Meghan C	Instructional 1 Grades PK-4 (2825);Instructional 1 Grades 5-6 (2826)	Teacher - Computer Literacy
5359412	Marquis, Weston J	Instructional 2 Elementary K-6 (2810);Instructional 2 Early Childhood N-3 (2840);Instructional 2 Reading Specialist PK-12 (7650)	Teacher - U.S. History
6786742	Moyer, Jill A	Instructional 1 Earth and Space Science 7-12 (8440);Instructional 1 Social Studies 7-12 (8875)	Teacher - Learning Support - HS
6950107	Ryen, Brianne B	Endorsement Instructional Coach PK-12 (1182);Instructional 2 Elementary K-6 (2810);Instructional 2 Mid-Level English 6-9 (2850);Instructional 2 English 7-12 (3230);Instructional 2 Reading Specialist PK-12 (7650);Instructional 2 Special Education PK-12 (9225)	Instructional Coach - General Education - Middle S
8726136	Buck, Jill	Instructional HOUSSE Designation General Science 7-12 (8450)	Teacher - 3rd Grade Math
3865179	Baird, Ryan D	Instructional 2 Elementary K-6 (2810);Instructional 2 Mid-Level Mathematics 6-9 (2860);Instructional 2 Special Education PK-12 (9225)	Family Coach
6121506	Center, Tina	Administrative 1 Principal PK-12 (1115);Supervisory Supvr Curriculum & Inst PK-12 (2915);Instructional 2 Communications 7-12 (3200);Instructional 2 English 7-12 (3230)	Teacher - Spanish
9214593	Staab, Michelle L	Instructional 2 Art PK-12 (1405)	Teacher - 2nd Grade
3183984	Lewis, Jennifer Rebecca	Educational Specialist 2 School Nurse PK-12 (1890)	Remedial Specialist - Reading - 1st Grade; Remedial Specialist - Reading - 2nd Grade; Remedial Specialist - Reading - Kindergarten
9454898	Folmar, Paul R	Instructional 2 English 7-12 (3230)	Teacher - Geometry
1464047	Ruffner, Zoleanne S	Instructional 2 Elementary K-6 (2810);Instructional 2 Reading Specialist PK-12 (7650);Instructional 2 Special Education PK-12 (9225)	Teacher - 8th Grade History
1810325	Perri, Renee C	Instructional 1 Mathematics 7-12 (6800)	Teacher - Life Skills - HS
3056185	Moyer, Amanda J	Instructional 2 Social Studies 7-12 (8875)	Teacher - Learning Support - HS
5837679	Denham, Angela M	Instructional 2 Mathematics 7-12 (6800)	Teacher - Transition
3521429	Martinez, Barbara Ann	Instructional 1 Mathematics 7-12 (6800)	Teacher - 6th Grade History
5735753	Vietmeier, Stacy L	Instructional 2 Social Studies 7-12 (8875)	Teacher - Life Skills - K-8

State ID	Employee Name	Areas of Certification Type of Certificate	Grades Teaching or Serving
8537103	Brown, Kathleen A	Instructional 2 Elementary K-6 (2810);Program Specialist English as a Second Language (ESL) PK-12 (4499);Instructional 2 Ment and/or Phys Handicapped K-12 (9235)	Teacher - Accounting; Teacher - Marketing I; Teacher - Intro to Entrepreneurship I
8757232	McGeehan, Rebecca A	Instructional 2 English 7-12 (3230);Instructional 2 Social Studies 7-12 (8875)	Teacher - Substitute - Special Education - HS
6859102	Ferrier, Cassandra L	Instructional 1 Grades PK-4 (2825)	Teacher - 8th Grade English Language Arts
1678431	Gasol, Melissa	Instructional 2 English 7-12 (3230);Instructional 2 Social Studies 7-12 (8875)	Teacher - Emotional Support - HS
1830841	Armstrong, Amanda K	Educational Specialist 2 Secondary School Counselor 7-12 (1837);Instructional 2 Mathematics 7-12 (6800)	Teacher - Learning Support - HS
9328097	Deemer, Judith	Instructional 2 Elementary K-6 (2810);Instructional 2 Mid-Level Mathematics 6-9 (2860);Instructional 2 Mid-Level Citiz. Ed 6-9 (2870)	Teacher - Autistic Support - HS
1529129	Majzlik, Angela	Administrative 2 Principal PK-12 (1115);Instructional 2 Social Studies 7-12 (8875)	Teacher - 2nd Grade
9157434	Mastropietro, Melissa	Instructional 2 Grades PK-4 (2825);Instructional 2 Special Education PK-8 (9226)	Teacher - 1st Grade
5735207	Panchura, Chelsey	Instructional 1 Grades PK-4 (2825);Instructional 1 Special Education PK-8 (9226)	Teacher - Life Skills - HS
2562529	Watts, Brigitt	Instructional 1 Elementary K-6 (2810);Instructional 1 Mid-Level Mathematics 6-9 (2860);Instructional 1 Grades 4-8 (All subjects 4-6 ELA & Reading (3100);Instructional 1 Grades 4-8 (All subjects 4-6 Science 7-8) (3100);Instructional 1 Grades 4-8 (All subjects 4-6, S Stud 7-8) (3100SS)	Teacher - Foundations of Art; Teacher - 3D Animation
2354696	White, Andrew	Instructional 2 Elementary K-6 (2810);Instructional 2 Mid-Level English 6-9 (2850);Instructional 2 Mid-Level Citiz. Ed 6-9 (2870)	Teacher - 6th Grade Science
6309037	Stenson, Lauren	Instructional 2 Agriculture PK-12 (1200)	Guidance Counselor - Middle School
5397505	O'Donnell, Dana	Educational Specialist 1 School Nurse PK-12 (1890)	Teacher - Autistic Support - K-8
4721493	Costanzo, Kristal	Instructional 1 Biology 7-12 (8405)	Teacher - Learning Support - K-8
2480142	Farster, Ashley Lynne	Instructional 1 Reading Specialist PK-12 (7650);Instructional 1 Special Education PK-8 (9226);Instructional 1 Special Education 7-12 (9227)	Teacher - Learning Support - K-8
3690615	Erdmann, Melissa	Instructional 2 Mathematics 7-12 (6800)	Remedial Specialist - Reading - 3rd Grade; Remedial Specialist - Reading - 4th Grade; Remedial Specialist - Reading - 5th Grade
1536781	Kreutzer, Candace	Instructional 2 English 7-12 (3230)	MTSS Coordinator - Elementary School
5475409	Hawk, Kristie	Instructional 2 Ment and/or Phys Handicapped K-12 (9235)	Assistant Principal - Elementary School
3612063	Brisbane, Amber	Instructional 1 Grades PK-4 (2825);Instructional 1 Spanish PK-12 (4490)	Teacher - Transition
6797603	Sweeney, Allison	Instructional 2 Elementary K-6 (2810);Instructional 2 English 7-12 (3230);Instructional 2 Ment and/or Phys Handicapped K-12 (9235)	Teacher - Learning Support - HS
4957692	Sams, Rachel	Instructional 1 Elementary K-6 (2810);Instructional 1 Ment and/or Phys Handicapped K-12 (9235)	Remedial Specialist - Math - 3rd Grade; Remedial Specialist - Math - 4th Grade; Remedial Specialist - Math - 5th Grade

State ID	Employee Name	Areas of Certification Type of Certificate	Grades Teaching or Serving
8028262	Brand, Catherine	Instructional 1 Social Studies 7-12 (8875)	Teacher - 7th Grade Math
2569601	Dodge, Heidi Marie	Instructional 2 Elementary K-6 (2810)	Teacher - Life Skills - K-8; Teacher - Multi-Disabilities - K-8
5341385	Shannon, Keri Beth	Instructional 2 Mathematics 7-12 (6800);Instructional 2 Physics 7-12 (8470)	Teacher - Learning Support - HS
6760832	Baker, Christian	Administrative 2 Principal PK-12 (1115);Instructional 2 Mathematics 7-12 (6800)	Teacher - Learning Support - K-8
2602809	Brennan, Jean Marie	Instructional 2 Elementary K-6 (2810);Supervisory Supvr Special Education PK-12 (9215);Instructional 2 Special Education PK-12 (9225)	Teacher - 5th Grade Math
8761485	Frederick, Holly Anne	Educational Specialist 2 Elementary School Counselor K-6 (1836);Educational Specialist 2 Secondary School Counselor 7-12 (1837)	Teacher - 6th Grade Computer Literacy
1659046	Menzler, Sarah Elizabeth	Instructional 2 English 7-12 (3230);Instructional 2 Citizenship 7-12 (8825);Instructional 2 Social Studies 7-12 (8875)	Teacher - U.S. History
8491596	Brestensky, Lisa	Instructional 2 Elementary K-6 (2810);Instructional 2 Mid-Level Mathematics 6-9 (2860);Instructional 2 Mid-Level Science 6-9 (2880);Instructional 2 Earth and Space Science 7-12 (8440)	Teacher - Learning Support - HS
8191468	Gallis, Kimberly Ann	Instructional 2 Grades PK-4 (2825);Instructional 2 Mid-Level Mathematics 6-9 (2860);Instructional 2 Reading Specialist PK-12 (7650)	Teacher - 4th Grade Math
5430595	Smith, Laurie B	Instructional 2 Biology 7-12 (8405);Instructional 2 General Science 7-12 (8450)	Chief Human Resources Officer
2742075	Vuong Schmick, Thy Minh	Instructional 1 Grades PK-4 (2825)	Teacher - 8th Grade Science
5973673	Barber, Constance	Educational Specialist 2 Elementary School Counselor K-6 (1836);Educational Specialist 2 Secondary School Counselor 7-12 (1837)	Teacher - 2nd Grade; Teacher - 3rd Grade English Language Arts; Teacher - 4th Grade English Language Arts; Teacher - 5th Grade English Language Arts
3672897	Cuviello, Grace	Instructional 2 Earth and Space Science 7-12 (8440);Instructional 2 General Science 7-12 (8450)	Teacher - 1st Grade; Teacher - Substitute - General Education - Element
6989082	Cantwell, Brittney Taylor	Instructional 2 Social Studies 7-12 (8875)	Teacher - Learning Support - K-8
6586245	Hill, Lisa M	Instructional 2 Elementary K-6 (2810);Instructional 2 Special Education PK-12 (9225)	Remedial Specialist - Reading - 1st Grade; Remedial Specialist - Reading - 2nd Grade; Remedial Specialist - Reading - Kindergarten
3606539	Hartman, Cathrine S	Instructional 1 Elementary K-6 (2810);Instructional 1 Special Education PK-12 (9225)	Teacher - Learning Support - K-8
2865256	Staley, Amber	Instructional 2 Elementary K-6 (2810);Instructional 1 Reading Specialist PK-12 (7650);Instructional 2 Special Education PK-12 (9225)	Teacher - Life Skills - HS
5303639	Richards-Walter, Marisa Grace	Instructional 2 Elementary K-6 (2810);Instructional 2 Reading Specialist PK-12 (7650)	Teacher - 8th Grade Math
6327305	Bargerstock, Whitney E	Instructional 2 Elementary K-6 (2810)	Instructional Coach - Special Education - HS
5179051	Wilson, Misty L	Instructional 2 Grades PK-4 (2825);Instructional 2 Special Education PK-8 (9226)	Family Coach

State ID	Employee Name	Areas of Certification Type of Certificate	Grades Teaching or Serving
8048158	Garczynski, Molly E	Endorsement 1 Instructional Coach PK-12 (1182);Instructional 2 Elementary K-6 (2810);Instructional 2 Early Childhood N-3 (2840);Instructional 2 English 7-12 (3230);Instructional 2 Special Education PK-12 (9225)	Enrollment Specialist; Teacher - Learning Support - K-8
5403689	Emrick, Carissa Robyn	Instructional 2 French PK-12 (4410);Instructional 2 Mathematics 7-12 (6800)	Teacher - Learning Support - HS
4621512	Allcorn, Brynne Nadine	Instructional 2 Health PK-12 (4810);Instructional 2 Reading Specialist PK-12 (7650);Instructional 2 Biology 7-12 (8405);Instructional 2 Special Education PK-12 (9225)	Teacher - Spanish
6247232	Renner, Katherine	Instructional 2 Elementary K-6 (2810);Instructional 2 Mid-Level Mathematics 6-9 (2860);Instructional 2 Special Education PK-12 (9225)	Family Coach
3621041	McGlothlin, Shelly L	Educational Specialist 2 Secondary School Counselor 7-12 (1837);Instructional 1 Elementary K-6 (2810)	Teacher - Literary Analysis and Composition I
8190103	Ramsey, Cathryn A	Instructional 1 English 7-12 (3230);Instructional 1 Special Education 7-12 (9227)	Teacher - Learning Support - K-8
9045025	Linderman, Jessica L	Instructional 2 English 7-12 (3230);Instructional 2 Special Education PK-12 (9225)	Teacher - Emotional Support - K-8
1961894	Whitten, Anne Starr	Instructional 1 Grades PK-4 (2825);Instructional 1 English 7-12 (3230)	Teacher - Literary Analysis and Composition I
1652126	Salimbene, Ashley Marie	Letter of Equivalency Master's Equivalency - (1185);Instructional 2 Elementary K-6 (2810);Instructional 2 Grades 4-8 (All subjects 4-6 Math 7-8) (3100)	Teacher - Learning Support - K-8
8539581	Butler, Anne M	Instructional 2 Elementary K-6 (2810);Instructional 2 English 7-12 (3230);Program Specialist English as a Second Language (ESL) PK-12 (4499);Instructional 2 Family-Consumer Sci PK-12 (5600);Instructional 2 Special Education PK-12 (9225)	Chief Academic Officer
3809193	O Donnell, Katie E	Educational Specialist 2 Secondary School Counselor 7-12 (1837)	Teacher - Learning Support - HS
2918713	Scears, Breanne M	Instructional 1 English 7-12 (3230)	Teacher - Autistic Support - HS
5906173	Porreca, Jessica A	Instructional 1 Elementary K-6 (2810)	Family Coach
5839145	Furka, David J	Instructional 2 Elementary K-6 (2810);Instructional 2 Early Childhood N-3 (2840);Instructional 2 Special Education PK-12 (9225)	Teacher - Autistic Support - K-8
3523082	Freyvogel Bruss, Colleen L	Instructional 2 English 7-12 (3230);Instructional 2 Library Science PK-12 (6420);Instructional 2 Reading Specialist PK-12 (7650)	Assistant Director - Special Education - HS
1673067	Ganter, Crysta M	Instructional 2 Elementary K-6 (2810);Instructional 2 Mid-Level Science 6-9 (2880);Instructional 2 Earth and Space Science 7-12 (8440)	Teacher - Kindergarten
9616535	Pontious, Brianna	Instructional 2 Elementary K-6 (2810);Instructional 2 Special Education PK-12 (9225)	Teacher - Autistic Support - K-8
4834051	Jimenez Brodie, Elinore	Instructional 2 Health & Physical Educ PK-12 (4805)	Teacher - Spanish
3274058	Huff, Ashley N	Instructional 1 Grades PK-4 (2825);Instructional 1 Special Education PK-8 (9226)	Teacher - Kindergarten
7276923	Morris, Elizabeth	Instructional 1 Elementary K-6 (2810)	Teacher - Substitute - General Education - HS
1431604	Beeken, Jennifer A	Instructional 1 Elementary K-6 (2810)	Teacher - Life Skills - HS

State ID	Employee Name	Areas of Certification Type of Certificate	Grades Teaching or Serving
2010834	Kammermeier, Amanda	Instructional 1 Elementary K-6 (2810)	Teacher - Learning Support - HS
9379892	Lapsker, Kristina	Educational Specialist 2 School Psychologist PK-12 (1875)	Teacher - Learning Support - K-8
1051274	DePietro, Jennifer	Educational Specialist 1 Secondary School Counselor 7-12 (1837)	Teacher - Transition
1205208	Severino, Jill	Instructional 2 Mathematics 7-12 (6800)	Teacher - Learning Support - K-8
3715812	Welsh, Kristy	Instructional 2 Elementary K-6 (2810)	Teacher - Life Skills - HS
3791683	Rodriguez, Gina	Instructional 2 Social Studies 7-12 (8875)	Teacher - Learning Support - K-8
6136347	Young, Sasha	Instructional 2 Elementary K-6 (2810);Instructional 2 Early Childhood N-3 (2840);Instructional 2 Reading Specialist PK-12 (7650)	Teacher - Learning Support - HS
2941592	Ambuka, Tracey	Instructional 1 Elementary K-6 (2810);Instructional 1 Reading Specialist PK-12 (7650);Instructional 1 Special Education PK-12 (9225)	Teacher - Learning Support - HS
8593738	Moreno, Catherine	Instructional 2 Elementary K-6 (2810);Instructional 2 Mid-Level Science 6-9 (2880)	Teacher - 5th Grade Science
3853409	Leonard, Katie	Instructional 2 Elementary K-6 (2810)	Teacher - Algebra II
1827494	Imbarlina, Cindy	Administrative 1 Principal PK-12 (1115);Instructional 2 Elementary K-6 (2810);Instructional 2 Early Childhood N-3 (2840);Instructional 2 Special Education PK-12 (9225)	Family Coach
9503858	McCreary, Adrienne	Instructional 2 Biology 7-12 (8405)	Remedial Specialist - Reading - 3rd Grade; Remedial Specialist - Reading - 4th Grade; Remedial Specialist - Reading - 5th Grade
7521308	Salony, Lisa	Instructional 2 Elementary K-6 (2810);Instructional 2 Technology Education PK-12 (6075);Instructional 2 Special Education PK-8 (9226);Instructional 2 Special Education Expansion 7-12 (9229)	Teacher - 5th Grade English Language Arts
7090607	Haney-Filippone, Heather Jo	Instructional 2 Elementary K-6 (2810);Instructional 2 English 7-12 (3230);Instructional 2 Family-Consumer Sci PK-12 (5600)	Teacher - Learning Support - K-8
2786425	Wise, Ashley R	Instructional 1 Grades PK-4 (2825);Instructional 1 Special Education PK-8 (9226)	Teacher - 2nd Grade
3602713	Breyak, Laurel	Instructional 2 Elementary K-6 (2810);Instructional 2 Mid-Level Mathematics 6-9 (2860);Instructional 2 Special Education PK-8 (9226)	Teacher - 5th Grade Social Studies
7032767	Egan, Colleen Denise	Instructional 2 Elementary K-6 (2810);Instructional 2 Early Childhood N-3 (2840);Instructional 2 English 7-12 (3230)	Family Coach
9298295	Alcorn, Ashley Elizabeth-Nicol	Instructional 2 Elementary K-6 (2810);Instructional 2 English 7-12 (3230);Instructional 2 Reading Specialist PK-12 (7650);Instructional 2 Ment and/or Phys Handicapped K-12 (9235)	Teacher - 3rd Grade Math
4102713	Cobert, Heather Leann	Instructional 1 Elementary K-6 (2810)	Teacher - Life Skills - HS
6463102	Kerns, Lauren Diehl	Instructional 1 Reading Specialist PK-12 (7650)	Teacher - Emotional Support - HS
6179747	Cooper, Barbara J	Instructional 1 Bus-Computer-Info Tech PK-12 (1603)	Teacher - Learning Support - HS
6989536	Webb, Ryan Michael	Instructional 1 Elementary K-6 (2810);Instructional 1 Mid-Level Mathematics 6-9 (2860)	Teacher - Physical Education

State ID	Employee Name	Areas of Certification Type of Certificate	Grades Teaching or Serving
7165636	Huffman, Jena Mae	Instructional 1 Grades 4-8 (All subjects 4-6 Science 7-8) (3100);Instructional 1 Family-Consumer Sci PK-12 (5600);Instructional 1 Biology 7-12 (8405)	Teacher - Autistic Support - HS
5176786	Hollenbach, Nicolette Marie	Instructional 1 Grades PK-4 (2825);Instructional 1 Special Education PK-8 (9226)	Teacher - Life Skills - HS
8174539	Pricer, Danielle Elizabeth	Instructional 2 Music PK-12 (7205)	School Psychologist
7576873	Connelly, Jennifer Marie	Instructional 1 Elementary K-6 (2810)	Remedial Specialist - Reading - 1st Grade; Remedial Specialist - Reading - 2nd Grade; Remedial Specialist - Reading - Kindergarten
9614984	Emminger, Lauren Louise	Instructional 1 Health & Physical Educ PK-12 (4805)	Teacher - Emotional Support - HS
3031572	Binder, Tawny Norma	Instructional 1 Bus-Computer-Info Tech PK-12 (1603);Instructional 1 Elementary K-6 (2810)	Teacher - 2nd Grade
1097861	Love, Melissa Anne	Educational Specialist 2 Elementary School Counselor K-6 (1836);Educational Specialist 2 Secondary School Counselor 7-12 (1837)	Teacher - Learning Support - HS
6193169	Lyman, Stephanie M	Instructional 1 Grades PK-4 (2825);Instructional 1 Special Education PK-8 (9226)	Family Coach
3816487	Marsiliano, Judy	Instructional 1 Grades PK-4 (2825)	Teacher - Geometry
3460531	Berstecher, Kelly Ann	Instructional 2 Elementary K-6 (2810)	Teacher - Autistic Support - K-8
5689261	Flores, Kayla Lynn	Endorsement Online Instruction Program PK-12 (1184);Instructional 2 Mathematics 7-12 (6800)	Enrollment Specialist
6278342	England, Emilee Grace	Instructional 1 Biology 7-12 (8405)	Orientation Advisor; Orientation Advisor Substitute; Teacher - Substitute - General Education - HS
6237909	Adams, Serena Renee	Instructional 2 Elementary K-6 (2810);Instructional 2 Early Childhood N-3 (2840)	Teacher - Emotional Support - HS
1291348	Schar, Jill C	Instructional 2 Social Studies 7-12 (8875);Instructional 2 Special Education 7-12 (9227)	Teacher - 4th Grade Social Studies
4603802	Raught, Amy J	Instructional 1 Elementary K-6 (2810)	Teacher - Emotional Support - HS; Teacher - Learning Support - HS
1983458	McCready, Melissa Sue	Instructional 2 Elementary K-6 (2810);Instructional 2 Early Childhood N-3 (2840);Instructional 2 Family-Consumer Sci PK-12 (5600);Instructional 2 Reading Specialist PK-12 (7650)	Teacher - 5th Grade Science
7028645	Shoop, Elizabeth Ann	Instructional 2 Elementary K-6 (2810)	Teacher - 6th Grade History
1585189	Draeger, Theresa M	Instructional 1 Elementary K-6 (2810);Instructional 1 Mid-Level English 6-9 (2850);Instructional 1 Mid-Level Mathematics 6-9 (2860)	Teacher - Learning Support - HS
3813852	McMullen, Daniel Christopher	Educational Specialist 1 Inst Technology Specialist PK-12 (1825);Instructional 2 Elementary K-6 (2810);Instructional 2 Mid-Level English 6-9 (2850);Instructional 2 Mid-Level Mathematics 6-9 (2860);Instructional 2 Mid-Level Citiz. Ed 6-9 (2870);Instructional 2 Mid-Level Science 6-9 (2880);Instructional 2 Reading Specialist PK-12 (7650)	Teacher - Continuing Algebra; Teacher - Geometry



State ID	Employee Name	Areas of Certification Type of Certificate	Grades Teaching or Serving
2832436	Bost, Carissa Marie	Instructional 2 Biology 7-12 (8405);Instructional 2 Chemistry 7-12 (8420);Instructional 2 Special Education PK-12 (9225)	Family Coach
9169278	Brownlie, Victoria Eugenia	Instructional 2 Elementary K-6 (2810);Instructional 2 Mid-Level English 6-9 (2850);Instructional 2 Reading Specialist PK-12 (7650);Instructional 2 Special Education PK-12 (9225)	Teacher - Spanish
1576568	Rizzo, Felicia L	Instructional 2 Elementary K-6 (2810);Supervisory Supvr Special Education PK-12 (9215);Instructional 2 Special Education PK-12 (9225)	Teacher - 3rd Grade Social Studies
5086528	Compton, Nancy Lee	Instructional 1 Elementary K-6 (2810)	School Social Worker
7934971	Large, Allison Lee	Instructional 1 General Science 7-12 (8450)	Teacher - Learning Support - HS
2746171	Cadieus, Jennifer	Instructional 2 Social Studies 7-12 (8875)	Teacher - Life Skills - HS
5835909	Stevens, Brett Elizabeth	Instructional 2 Elementary K-6 (2810);Instructional 2 Special Education PK-12 (9225)	Teacher - Life Skills - HS
5207967	Reese, Jessica Sara	Endorsement Gifted PK-12 (1189);Instructional 2 Elementary K-6 (2810);Instructional 2 Reading Specialist PK-12 (7650);Instructional 2 Special Education PK-12 (9225)	Teacher - Learning Support - K-8
5494746	Mikkelsen, Melissa Marie	Private School - Asst or Teacher Nursery/Kindergarten N-K (12833);Instructional 2 Elementary K-6 (2810)	Teacher - Kindergarten
1630868	Pelipesky, Michele Anne	Instructional 2 Environmental Educ PK-12 (4820);Instructional 2 Earth and Space Science 7-12 (8440);Instructional 2 General Science 7-12 (8450)	Family Coach
6974651	Arcuri, Camille Lynn	Private School - Teacher Mentally Retarded K-12 (19220);Private School - Teacher Soc and Emotionally Dist K-12 (19260);Instructional 2 Elementary K-6 (2810);Instructional 2 Special Education PK-12 (9225)	Teacher - 1st Grade
1716534	Robosky, Jalina A	Instructional 1 Health & Physical Educ PK-12 (4805);Instructional 1 Health PK-12 (4810)	Teacher - Kindergarten
7467268	McCracken, Melissa Kathryn	Instructional 2 Elementary K-6 (2810);Program Specialist English as a Second Language (ESL) PK-12 (4499);Instructional 2 Social Studies 7-12 (8875);Instructional 2 Ment and/or Phys Handicapped K-12 (9235)	Teacher - Learning Support - HS
6045927	Tomik, Amanda	Instructional 2 Elementary K-6 (2810)	Teacher - 4th Grade Math
5371396	Hoffman, Kaelyn McKenzie	Instructional 2 Elementary K-6 (2810);Instructional 2 Special Education PK-12 (9225)	Teacher - Learning Support - K-8
9075298	Chaffin, Casey	Instructional 2 Social Studies 7-12 (8875)	Teacher - Learning Support - K-8
7598317	Kaufman, Gillian Spencer	Instructional 2 Elementary K-6 (2810);Instructional HOUSSE Designation Mid-Level English 6-9 (2850);Instructional HOUSSE Designation Mid-Level Mathematics 6-9 (2860);Instructional 2 English 7-12 (3230);Instructional 2 Special Education PK-12 (9225)	Teacher - Autistic Support - K-8
4791514	Jacob, Linda Michelle	Educational Specialist 2 Secondary School Counselor 7-12 (1837)	Teacher - 2nd Grade
4156178	Kara, Rebecca J	Administrative 2 Principal PK-12 (1115);Instructional 2 Biology 7-12 (8405);Instructional 2 General Science 7-12 (8450)	Teacher - 3rd Grade English Language Arts

State ID	Employee Name	Areas of Certification Type of Certificate	Grades Teaching or Serving
2986176	Kozak, Tamara Ann	Instructional 2 Elementary K-6 (2810);Instructional 2 Mid-Level Mathematics 6-9 (2860);Instructional 2 Reading Specialist PK-12 (7650)	Teacher - Emotional Support - HS
7694718	Henriquez, Ibis Raquel	Educational Specialist 1 Elem. & Secondary School Counselor PK-12 (1839)	Family Coach
2613297	Weeks, Rachel Nicole	Instructional 2 Biology 7-12 (8405)	Teacher - Substitute - Special Education - K-8; Teacher - Learning Support - K-8
4904954	Franklin, Melissa Lynn	Instructional 2 Latin PK-12 (4030);Instructional 2 Social Studies 7-12 (8875)	Teacher - Learning Support - K-8
6943929	Baxter, Jenna Laken	Instructional 1 Elementary K-6 (2810)	Teacher - 3rd Grade Science
2959607	Morantz, Christina Marie	Educational Specialist 2 Elementary School Counselor K-6 (1836);Educational Specialist 2 Secondary School Counselor 7-12 (1837)	Teacher - 8th Grade Science
8692373	DoVidio, Domenica Rose	Instructional 2 Biology 7-12 (8405);Instructional 2 Chemistry 7-12 (8420)	Teacher - 1st Grade
6514235	McHugh, Kristin Lee	Instructional 2 Mid-Level Mathematics 6-9 (2860);Instructional 2 Social Studies 7-12 (8875)	Teacher - Fine Art; Teacher - Foundations of Art
2102439	Goff, Jaelynn Beeler	Instructional 2 English 7-12 (3230);Instructional 2 Ment and/or Phys Handicapped K-12 (9235)	Teacher - 7th Grade History
9384068	Conway, Meredith Dance	Instructional 2 Art PK-12 (1405)	Teacher - Kindergarten
3046982	Pascucci, Jeanne Marie	Instructional 1 English 7-12 (3230);Instructional 1 Family-Consumer Sci PK-12 (5600);Instructional 1 Mathematics 7-12 (6800)	Teacher - 8th Grade English Language Arts
2147268	Killam, Caroline Maria	Instructional HOUSSE Designation English 7-12 (3230);Instructional HOUSSE Designation Mathematics 7-12 (6800);Instructional HOUSSE Designation Social Studies 7-12 (8875);Supervisory Supvr Special Education PK-12 (9215);Instructional 2 Special Education PK-12 (9225)	Teacher - 7th Grade English Language Arts
3536269	Fine, Brianna Lynn	Instructional 2 Elementary K-6 (2810)	Teacher - 5th Grade Math
6341707	Cooper, Laura J	Instructional 2 Mid-Level Science 6-9 (2880);Instructional 2 Biology 7-12 (8405);Instructional 2 General Science 7-12 (8450)	Teacher - 3rd Grade Science
7959715	Gallagher, Heather Ann	Instructional 2 Mathematics 7-12 (6800)	Teacher - Learning Support - HS
6316362	Donahue, Lindsey Marie	Instructional 2 Social Studies 7-12 (8875)	Teacher - 3rd Grade English Language Arts
7279386	Atwood, Marlee Anna	Instructional 2 Health & Physical Educ PK-12 (4805)	Teacher - Autistic Support - K-8; Teacher - Learning Support - K-8
5967248	Morrow, Angelina Marie	Instructional 2 Communications 7-12 (3200);Instructional 2 English 7-12 (3230)	Teacher - Substitute - General Education - Element; Teacher - 1st Grade
5802785	Pust, Ronda Jean	Instructional 2 Social Studies 7-12 (8875)	Teacher - 1st Grade
8795053	Briley, Christie Leighann	Instructional 2 Elementary K-6 (2810);Instructional 2 Reading Specialist PK-12 (7650);Instructional 2 Special Education PK-12 (9225)	Teacher - 4th Grade Social Studies
9562753	DeFelice, Amanda Elaine	Educational Specialist 1 Elem. & Secondary School Counselor PK-12 (1839);Instructional 2 Ment and/or Phys Handicapped K-12 (9235)	Teacher - 6th Grade English Language Arts
3606263	Galloway, Kayla Anne	Instructional 2 Elementary K-6 (2810)	Teacher - 2nd Grade
8241017	Fegely, Joy Elaine	Instructional 2 Library Science PK-12 (6420);Instructional 2 Social Studies 7-12 (8875)	Teacher - Substitute - Special Education - HS

State ID	Employee Name	Areas of Certification Type of Certificate	Grades Teaching or Serving
1270659	Moran, Mary Katherine	Instructional 2 English 7-12 (3230)	Teacher - Substitute - General Education - Element
8439368	Bronson, Angelica Lauren	Instructional 2 Elementary K-6 (2810);Instructional 2 Special Education PK-12 (9225)	Teacher - Kindergarten
8263036	Scrip, Erin Marie	Instructional 1 Speech & Language Impaired PK-12 (9265)	Teacher - Life Skills - HS
5696493	Castillon McCarty, Arturo	Instructional 2 Elementary K-6 (2810);Instructional 2 Special Education PK-12 (9225)	Teacher - Substitute - General Education - HS; Teacher - Substitute - General Education - Middle
6167926	Ellis, Bridget Marie	Endorsement Gifted PK-12 (1189);Instructional 2 English 7-12 (3230)	Teacher - Learning Support - K-8
1653853	Bash, Theresa Ann	Instructional 1 Elementary K-6 (2810)	Teacher - Learning Support - K-8
7846349	Kubica, Regina Anne	Instructional 2 Elementary K-6 (2810)	Teacher - Learning Support - HS
9097202	Walters, Carrie Irene	Instructional 2 Art PK-12 (1405);Instructional 2 English 7-12 (3230);Instructional 2 Special Education PK-12 (9225)	Teacher - Substitute - General Education - Element
4956174	Leinweber, Brielle Carol	Instructional 2 Elementary K-6 (2810);Instructional 2 Mid-Level English 6-9 (2850);Instructional 2 Mid-Level Mathematics 6-9 (2860);Instructional 2 Mid-Level Citiz. Ed 6-9 (2870);Instructional 2 Mid-Level Science 6-9 (2880);Instructional 2 Health & Physical Educ PK-12 (4805);Instructional 2 Special Education PK-12 (9225)	Teacher - Substitute - General Education - Element
6028562	Byers, Colien Joanne	Instructional 2 Health & Physical Educ PK-12 (4805)	Teacher - Learning Support - HS
9431073	Marcello, Stefanie Marlene	Instructional 2 Elementary K-6 (2810);Instructional 2 Special Education PK-12 (9225)	Teacher - Learning Support - K-8
7192646	Flatley, Jennifer Marie	Instructional 1 Mathematics 7-12 (6800)	Teacher - Learning Support - HS
9482165	Hewitt, Denna Marcell	Instructional 1 Elementary K-6 (2810)	Teacher - Substitute - Special Education - K-8
8125834	Sarber, Carl William	Instructional 2 Elementary K-6 (2810);Instructional 2 Early Childhood N-3 (2840);Instructional 2 English 7-12 (3230);Instructional 2 Reading Specialist PK-12 (7650)	Teacher - 2nd Grade
7018432	Boyle, Jarin Tomas	Instructional 1 Grades PK-4 (2825);Instructional 1 Special Education PK-8 (9226)	Teacher - 4th Grade Social Studies
2614786	Connor, Erin Rose	Instructional 2 Elementary K-6 (2810);Instructional 2 Mid-Level English 6-9 (2850);Instructional 2 Mid-Level Mathematics 6-9 (2860);Instructional 2 Special Education PK-12 (9225)	Teacher - Learning Support - K-8
1953249	Ulewicz, Janet Marie	Instructional 2 Social Studies 7-12 (8875)	Teacher - Learning Support - K-8
4651015	Rosenbaum, Aliyah Marie	Instructional 1 Art PK-12 (1405)	Teacher - 1st Grade
4914824	Widlund, Shari Rachel	Private School - Asst or Teacher Nursery/Kindergarten N-K (12833);Instructional 2 Elementary K-6 (2810)	Teacher - Autistic Support - HS
1704203	Taggart, Andrea	Instructional 2 English 7-12 (3230);Instructional 2 Reading Specialist PK-12 (7650);Instructional 2 Social Studies 7-12 (8875)	Remedial Specialist - Reading - 1st Grade; Remedial Specialist - Reading - 2nd Grade; Remedial Specialist - Reading - Kindergarten
9813569	Carmichael, Rachel Marie	Instructional 1 Grades PK-4 (2825);Instructional 1 Grades 5-6 (2826)	Teacher - Learning Support - K-8
5415087	Amodeo, Kattreena Julia	Instructional 1 Earth and Space Science 7-12 (8440)	Teacher - Learning Support - K-8

State ID	Employee Name	Areas of Certification Type of Certificate	Grades Teaching or Serving
9076017	Riggle, Carmen Paige	Instructional 2 Elementary K-6 (2810);Instructional 2 Special Education PK-8 (9226)	Teacher - Learning Support - K-8
3059573	Yeager, Paola P	Administrative 1 Principal PK-12 (1115);Administrative Vocational Admin Dir. 7-12 (2300);Instructional 2 Mid-Level English 6-9 (2850);Instructional 2 Mid-Level Citiz. Ed 6-9 (2870);Instructional 2 Health & Physical Educ PK-12 (4805);Instructional 2 Safety Ed/Driver Ed 7-12 (5215);Instructional 2 Family-Consumer Sci PK-12 (5600)	Family Coach
4392169	Lavelle, Patrick Michael	Instructional 2 English 7-12 (3230);Instructional 2 Spanish PK-12 (4490)	Teacher - Substitute - Special Education - HS; Teacher - Emotional Support - HS
3543801	Giovanisci, Katy Veronica	Private School - Asst or Teacher Nursery/Kindergarten N-K (12833);Instructional 2 Elementary K-6 (2810)	Director - Curriculum, Instruction, & Assessment
2362143	McCleary, Sarah Lorraine	Instructional 2 Elementary K-6 (2810);Instructional HOUSSE Designation English 7-12 (3230);Instructional HOUSSE Designation General Science 7-12 (8450);Instructional HOUSSE Designation Social Studies 7-12 (8875);Instructional 2 Special Education PK-12 (9225)	Teacher - Substitute - General Education - Element
8262939	Harkins, Paul K	Instructional 2 Elementary K-6 (2810);Instructional 2 Mid-Level Mathematics 6-9 (2860);Instructional 2 Mid-Level Science 6-9 (2880)	Assistant Principal - High School
1657956	Walczak, Brittney Ann	Instructional 2 Mid-Level Science 6-9 (2880);Instructional 2 Chemistry 7-12 (8420)	Teacher - Learning Support - K-8
6232586	Riexinger, Anna Elizabeth	Instructional 1 Social Studies 7-12 (8875);Instructional 1 Special Education 7-12 (9227)	Teacher - Biology
4149081	Markle, Jennifer Louise	Instructional 1 Grades PK-4 (2825);Instructional 1 Special Education PK-8 (9226)	Teacher - Substitute - Special Education - HS; Teacher - Life Skills - HS
1324972	Scott, Heather Lee	Instructional 1 Special Education PK-12 (9225)	Teacher - Substitute - General Education - Middle
6284705	Dearwester, Mia Alexandra	Letter of Equivalency Master's Equivalency - (1185);Instructional 2 Elementary K-6 (2810);Instructional 2 Mid-Level English 6-9 (2850);Instructional 2 Mid-Level Mathematics 6-9 (2860);Program Specialist English as a Second Language (ESL) PK-12 (4499)	Teacher - Autistic Support - K-8
4171219	Canonge, Andrea Lauren	Instructional 1 Elementary K-6 (2810)	Teacher - 5th Grade Math
1023958	Butera, Maryann	Instructional 2 Mid-Level Science 6-9 (2880);Instructional 2 Reading Specialist PK-12 (7650);Instructional 2 Biology 7-12 (8405)	Teacher - Life Skills - HS
8072495	Deemer, Melissa Rebecca	Instructional 2 Bus-Computer-Info Tech PK-12 (1603);Instructional 2 Marketing 7-12 (1640);Instructional 2 Office Technologies 7-12 (1658);Program Specialist English as a Second Language (ESL) PK-12 (4499)	Teacher - 8th Grade Math
4867954	Davis, Megan Lynn	Instructional 2 Art PK-12 (1405);Instructional 2 Bus-Computer-Info Tech PK-12 (1603)	Teacher - Substitute - General Education - Element
1872304	McCabe, Megan Elizabeth	Instructional 2 Elementary K-6 (2810)	Certified School Nurse
1219598	Shaffer, Bethann	Instructional 1 Health & Physical Educ PK-12 (4805)	Teacher - Substitute - Special Education - K-8

State ID	Employee Name	Areas of Certification Type of Certificate	Grades Teaching or Serving
8037641	Mannarino, Stephanie Lynn	Instructional 1 Grades PK-4 (2825);Instructional 1 Special Education PK-8 (9226)	Teacher - Learning Support - K-8
9563287	Beschizza, Heather Grace	Instructional 2 Art PK-12 (1405)	Teacher - 5th Grade English Language Arts
8125042	Long, Naafeisha Tameka	Instructional 2 Social Studies 7-12 (8875)	Teacher - Substitute - Special Education - HS
8762691	Lorcheim, Kristine Frances	Instructional 2 Elementary K-6 (2810);Instructional 2 Mid-Level Mathematics 6-9 (2860);Instructional 2 Mid-Level Science 6-9 (2880);Instructional 2 Special Education PK-12 (9225)	Teacher - Learning Support - K-8
9361723	Mecchia, Jaime Diana	Educational Specialist 1 Elem. & Secondary School Counselor PK-12 (1839);Instructional 1 Special Education PK-12 (9225)	Teacher - Life Skills - HS
4540246	Gruszewski, Amanda Marie	Instructional 1 Grades 4-8 (All subjects 4-6, S Stud 7-8) (3100SS)	Teacher - Autistic Support - K-8
6460725	Morris, Allyson Elizabeth	Instructional 2 Elementary K-6 (2810);Instructional 2 Reading Specialist PK-12 (7650)	Teacher - Substitute - Special Education - HS; Teacher - Learning Support - HS
8646283	Short, Jonna Rose	Instructional 1 Elementary K-6 (2810)	Teacher - 1st Grade
3097454	Rakowski, Pamela Denise	Administrative 1 Principal PK-12 (1115);Instructional 2 Elementary K-6 (2810);Instructional 2 Mid-Level Science 6-9 (2880);Instructional 2 Reading Specialist PK-12 (7650)	Teacher - Substitute - General Education - Element
1493634	Emsurak, Janeen M	Educational Specialist 2 Elementary School Counselor K-6 (1836);Educational Specialist 2 Secondary School Counselor 7-12 (1837)	Teacher - Substitute - Special Education - HS
7439432	Luciano, Elizabeth Kathryn	Instructional 1 Elementary K-6 (2810);Instructional 1 Reading Specialist PK-12 (7650)	Teacher - Substitute - General Education - Middle; Teacher - 5th Grade Math
5841612	Dimov-Gottshall, Emily Marie	Educational Specialist 1 Inst Technology Specialist PK-12 (1825);Instructional 2 Social Studies 7-12 (8875)	Teacher - Substitute - General Education - Element
7191053	Yadsko, Alexzandria EmilyAnn	Instructional 2 Mid-Level English 6-9 (2850);Instructional 2 Mid-Level Citiz. Ed 6-9 (2870)	Teacher - Substitute - General Education - Element
7465124	Joseph, Margret Rene	Instructional 2 Elementary K-6 (2810);Instructional 2 Special Education PK-12 (9225)	Teacher - Substitute - General Education - Element
3865127	Mangano, Melissa Marie	Instructional 2 Elementary K-6 (2810);Instructional HOUSSE Designation Mid-Level English 6-9 (2850);Instructional 2 Mid-Level English 6-9 (2850);Instructional HOUSSE Designation English 7-12 (3230);Instructional 2 Special Education PK-12 (9225)	Teacher - 4th Grade English Language Arts
2598387	Hardy, Emily Elizabeth	Instructional 2 Elementary K-6 (2810)	Teacher - Learning Support - K-8
4320476	Spindler, Amber L	Administrative 1 Principal PK-12 (1115);Instructional 2 Mathematics 7-12 (6800)	Teacher - Learning Support - K-8
6208603	Ferenchick, Tyler Alexander	Administrative 1 Principal PK-12 (1115);Instructional 2 Elementary K-6 (2810);Instructional 2 Early Childhood N-3 (2840);Instructional 2 Mid-Level English 6-9 (2850);Instructional 2 English 7-12 (3230);Instructional 2 Family-Consumer Sci PK-12 (5600);Instructional 2 Social Studies 7-12 (8875)	Teacher - Substitute - General Education - Middle
4108214	Trott, Alyssa Marie	Instructional 1 Mathematics 7-12 (6800)	Teacher - Learning Support - HS

State ID	Employee Name	Areas of Certification Type of Certificate	Grades Teaching or Serving
7269024	Boisvert, Melody Rae	Administrative 1 Principal PK-12 (1115);Endorsement Instructional Coach PK-12 (1182);Instructional 2 Elementary K-6 (2810);Instructional 2 Mid-Level Mathematics 6-9 (2860);Instructional 2 Reading Specialist PK-12 (7650)	Teacher - 3rd Grade English Language Arts
5385905	Elmquist, Dana Lynn	Administrative 1 Principal PK-12 (1115);Instructional 2 Elementary K-6 (2810);Instructional 2 Mid-Level English 6-9 (2850);Instructional 2 English 7-12 (3230)	School Psychologist
2806325	Gannon, Devin Richard	Instructional 1 English 7-12 (3230)	Teacher - Life Skills - HS
8167832	Hennig, Ashley Nicole	Instructional 2 Elementary K-6 (2810)	Teacher - Geometry
6383075	Moore, Kristen Lynn	Instructional 2 English 7-12 (3230);Supervisory Supvr Special Education PK-12 (9215);Instructional 2 Special Education PK-12 (9225)	Teacher - Learning Support - K-8
9108013	Hardisky, Jennifer Rebecca	Instructional 2 Elementary K-6 (2810);Instructional 2 Early Childhood N-3 (2840)	Teacher - Substitute - General Education - HS
8945741	Horst, Nicole Elizabeth	Instructional 2 Mathematics 7-12 (6800)	ELL Specialist
9246035	Kwiecinski, Dana Susan	Endorsement Instructional Coach PK-12 (1182);Private School - Asst or Teacher Nursery/Kindergarten N-K (12833);Instructional 2 Elementary K-6 (2810);Instructional 2 Early Childhood N-3 (2840)	Teacher - Learning Support - HS
7315086	Heppenstall, Amber Paige	Instructional 1 Grades PK-4 (2825)	Teacher - Learning Support - K-8
6732795	Titus, Lorna Francesca	Instructional 1 Reading Specialist PK-12 (7650)	Teacher - Learning Support - HS; Teacher - Life Skills - HS
1861738	Chiado, Nicole Lynn	Non-Certified Educator Designation Non-Certified Educator PK-12 (20000)	Teacher - Learning Support - K-8
1601727	Thomas, Amber Marie	Instructional 2 Elementary K-6 (2810);Instructional 2 Special Education PK-12 (9225)	Teacher - Life Skills - HS
5620596	Forrest, Emily Christine	Educational Specialist 2 Secondary School Counselor 7-12 (1837)	Teacher - Learning Support - K-8
6168378	Brown, Brittany Marie	Instructional 2 Elementary K-6 (2810);Instructional 2 Reading Specialist PK-12 (7650)	Teacher - Substitute - Special Education - K-8
4210894	Rodzwic, Tara Lynn	Educational Specialist 2 Elementary School Counselor K-6 (1836);Educational Specialist 2 Secondary School Counselor 7-12 (1837)	Teacher - Learning Support - K-8
3478745	LeGendre, Annette Marie	Instructional Elementary K-6 (2810);Instructional HOUSSSE Designation English 7-12 (3230);Instructional Ment and/or Phys Handicapped K-12 (9235)	Teacher - 8th Grade Math
1837828	Kirby, Mary Jean	Instructional 2 Elementary K-6 (2810);Instructional 2 Special Education PK-12 (9225)	Teacher - Life Skills - HS

State ID	Employee Name	Certificate Type	Level Code	Certificate Description	
3895818	Aaronson, Michelina M	Instructional	2	Elementary K-6 (2810)	Instructional 2 Elementary K-6 (2810)
3895818	Aaronson, Michelina M	Instructional	2	Early Childhood N-3 (2840)	Instructional 2 Early Childhood N-3 (2840)
7147327	Abel, Keri A	Instructional	2	Elementary K-6 (2810)	Instructional 2 Elementary K-6 (2810)
7517906	Aber, Laura M	Instructional	2	Elementary K-6 (2810)	Instructional 2 Elementary K-6 (2810)
7517906	Aber, Laura M	Instructional	2	Family-Consumer Sci PK-12 (5600)	Instructional 2 Family-Consumer Sci PK-12 (5600)
7517906	Aber, Laura M	Instructional	2	Reading Specialist PK-12 (7650)	Instructional 2 Reading Specialist PK-12 (7650)
7517906	Aber, Laura M	Instructional	2	Ment and/or Phys Handicapped K-12 (9235)	Instructional 2 Ment and/or Phys Handicapped K-12 (9235)
8947683	Abul Ela, Christina C	Instructional	2	Mathematics 7-12 (6800)	Instructional 2 Mathematics 7-12 (6800)
8947683	Abul Ela, Christina C	Instructional	2	Chemistry 7-12 (8420)	Instructional 2 Chemistry 7-12 (8420)
9413189	Acland, Kathrine Rita	Instructional	2	Bus-Computer-Info Tech PK-12 (1603)	Instructional 2 Bus-Computer-Info Tech PK-12 (1603)
9413189	Acland, Kathrine Rita	Instructional	2	English 7-12 (3230)	Instructional 2 English 7-12 (3230)
9413189	Acland, Kathrine Rita	Instructional	2	Mathematics 7-12 (6800)	Instructional 2 Mathematics 7-12 (6800)
9413189	Acland, Kathrine Rita	Instructional	2	Biology 7-12 (8405)	Instructional 2 Biology 7-12 (8405)
9413189	Acland, Kathrine Rita	Instructional	2	Social Studies 7-12 (8875)	Instructional 2 Social Studies 7-12 (8875)
9413189	Acland, Kathrine Rita	Instructional	2	Special Education PK-12 (9225)	Instructional 2 Special Education PK-12 (9225)
1524186	Adams, Rebecca Rose	Endorsement	1	Instructional Coach PK-12 (1182)	Endorsement 1 Instructional Coach PK-12 (1182)
1524186	Adams, Rebecca Rose	Instructional	2	Mid-Level Mathematics 6-9 (2860)	Instructional 2 Mid-Level Mathematics 6-9 (2860)
6237909	Adams, Serena Renee	Instructional	1	Grades 4-8 (All subjects 4-6 ELA & Reading (3100)	Instructional 1 Grades 4-8 (All subjects 4-6 ELA & Reading (3100)
6237909	Adams, Serena Renee	Instructional	1	Special Education PK-8 (9226)	Instructional 1 Special Education PK-8 (9226)
6237909	Adams, Serena Renee	Instructional	1	Special Education Expansion 7-12 (9229)	Instructional 1 Special Education Expansion 7-12 (9229)
9170369	Adrienne, Jennifer Kathleen	Instructional	2	Social Studies 7-12 (8875)	Instructional 2 Social Studies 7-12 (8875)
9298295	Alcorn, Ashley Elizabeth-Nicol	Instructional	1	Grades PK-4 (2825)	Instructional 1 Grades PK-4 (2825)
7984937	Alcott, Elyse M	Instructional	1	Elementary K-6 (2810)	Instructional 1 Elementary K-6 (2810)
7327629	Alderson, Jordan M	Private School - Teacher		English: Sec. Ed. 9-12 (13230)	Private School - Teacher English: Sec. Ed. 9-12 (13230)
7327629	Alderson, Jordan M	Instructional	1	Communications 7-12 (3200)	Instructional 1 Communications 7-12 (3200)
7327629	Alderson, Jordan M	Instructional	1	English 7-12 (3230)	Instructional 1 English 7-12 (3230)
4621512	Allcorn, Brynne Nadine	Instructional	2	Spanish PK-12 (4490)	Instructional 2 Spanish PK-12 (4490)
5168579	Allen, Betty A	Administrative	2	Principal PK-12 (1115)	Administrative 2 Principal PK-12 (1115)
5168579	Allen, Betty A	Instructional	2	Elementary K-6 (2810)	Instructional 2 Elementary K-6 (2810)
5168579	Allen, Betty A	Instructional	2	Mid-Level English 6-9 (2850)	Instructional 2 Mid-Level English 6-9 (2850)
5168579	Allen, Betty A	Instructional	2	Reading Specialist PK-12 (7650)	Instructional 2 Reading Specialist PK-12 (7650)
6813572	Altman, Dorry Ann	Instructional	2	English 7-12 (3230)	Instructional 2 English 7-12 (3230)
8328516	Ambrose, Danielle	Educational Specialist	2	Secondary School Counselor 7-12 (1837)	Educational Specialist 2 Secondary School Counselor 7-12 (1837)
2941592	Ambuka, Tracey	Instructional	2	Mid-Level Mathematics 6-9 (2860)	Instructional 2 Mid-Level Mathematics 6-9 (2860)
2941592	Ambuka, Tracey	Instructional	2	Family-Consumer Sci PK-12 (5600)	Instructional 2 Family-Consumer Sci PK-12 (5600)
2941592	Ambuka, Tracey	Instructional	HOUSSE	Mathematics 7-12 (6800)	Instructional HOUSSE Designation Mathematics 7-12 (6800)
2941592	Ambuka, Tracey	Instructional	2	Ment and/or Phys Handicapped K-12 (9235)	Instructional 2 Ment and/or Phys Handicapped K-12 (9235)
5415087	Amodeo, Kattreena Julia	Instructional	2	Elementary K-6 (2810)	Instructional 2 Elementary K-6 (2810)
5415087	Amodeo, Kattreena Julia	Instructional	2	Early Childhood N-3 (2840)	Instructional 2 Early Childhood N-3 (2840)
5415087	Amodeo, Kattreena Julia	Program Specialist		English as a Second Language (ESL) PK-12 (4499)	Program Specialist English as a Second Language (ESL) PK-12 (4499)
5415087	Amodeo, Kattreena Julia	Instructional	2	Reading Specialist PK-12 (7650)	Instructional 2 Reading Specialist PK-12 (7650)
5415087	Amodeo, Kattreena Julia	Instructional	2	Special Education PK-12 (9225)	Instructional 2 Special Education PK-12 (9225)
7145246	Anderson, Aisha N	Instructional	2	English 7-12 (3230)	Instructional 2 English 7-12 (3230)
7867191	Andrews, Lori Ann	Administrative	1	Principal PK-12 (1115)	Administrative 1 Principal PK-12 (1115)
7867191	Andrews, Lori Ann	Instructional	2	Mathematics 7-12 (6800)	Instructional 2 Mathematics 7-12 (6800)
2394931	Angelo, Shannon Lynn	Administrative	1	Principal PK-12 (1115)	Administrative 1 Principal PK-12 (1115)

State ID	Employee Name	Certificate Type	Level Code	Certificate Description	
2394931	Angelo, Shannon Lynn	Instructional	2	Elementary K-6 (2810)	Instructional 2 Elementary K-6 (2810)
6974651	Arcuri, Camille Lynn	Instructional	2	Elementary K-6 (2810)	Instructional 2 Elementary K-6 (2810)
6974651	Arcuri, Camille Lynn	Instructional	2	Special Education PK-12 (9225)	Instructional 2 Special Education PK-12 (9225)
1830841	Armstrong, Amanda K	Endorsement		Online Instruction Program PK-12 (1184)	Endorsement Online Instruction Program PK-12 (1184)
1830841	Armstrong, Amanda K	Instructional	2	Elementary K-6 (2810)	Instructional 2 Elementary K-6 (2810)
1830841	Armstrong, Amanda K	Instructional	2	Mid-Level Mathematics 6-9 (2860)	Instructional 2 Mid-Level Mathematics 6-9 (2860)
1830841	Armstrong, Amanda K	Instructional	2	Mid-Level Science 6-9 (2880)	Instructional 2 Mid-Level Science 6-9 (2880)
1830841	Armstrong, Amanda K	Instructional	2	Mathematics 7-12 (6800)	Instructional 2 Mathematics 7-12 (6800)
1830841	Armstrong, Amanda K	Instructional	2	Biology 7-12 (8405)	Instructional 2 Biology 7-12 (8405)
1830841	Armstrong, Amanda K	Instructional	2	Special Education PK-12 (9225)	Instructional 2 Special Education PK-12 (9225)
7279386	Atwood, Marlee Anna	Instructional	1	Health & Physical Educ PK-12 (4805)	Instructional 1 Health & Physical Educ PK-12 (4805)
7279386	Atwood, Marlee Anna	Instructional	1	Special Education PK-8 (9226)	Instructional 1 Special Education PK-8 (9226)
3865179	Baird, Ryan D	Educational Specialist	1	Inst Technology Specialist PK-12 (1825)	Educational Specialist 1 Inst Technology Specialist PK-12 (1825)
3865179	Baird, Ryan D	Instructional	2	Biology 7-12 (8405)	Instructional 2 Biology 7-12 (8405)
3695945	Baker, Andrea Marie	Instructional	1	Elementary K-6 (2810)	Instructional 1 Elementary K-6 (2810)
3695945	Baker, Andrea Marie	Instructional	1	Family-Consumer Sci PK-12 (5600)	Instructional 1 Family-Consumer Sci PK-12 (5600)
3695945	Baker, Andrea Marie	Instructional	1	Reading Specialist PK-12 (7650)	Instructional 1 Reading Specialist PK-12 (7650)
6760832	Baker, Christian	Instructional	2	English 7-12 (3230)	Instructional 2 English 7-12 (3230)
6760832	Baker, Christian	Instructional	2	Special Education PK-12 (9225)	Instructional 2 Special Education PK-12 (9225)
8750701	Balliet, Taylor Aisha	Instructional	1	Grades 4-8 (All subjects 4-6 Math 7-8) (3100)	Instructional 1 Grades 4-8 (All subjects 4-6 Math 7-8) (3100)
8750701	Balliet, Taylor Aisha	Instructional	1	Grades 4-8 (All subjects 4-6, S Stud 7-8) (3100SS)	Instructional 1 Grades 4-8 (All subjects 4-6, S Stud 7-8) (3100SS)
8750701	Balliet, Taylor Aisha	Instructional	1	Social Studies 7-12 (8875)	Instructional 1 Social Studies 7-12 (8875)
8347132	Baranoski, Anna M	Instructional	2	Grades PK-4 (2825)	Instructional 2 Grades PK-4 (2825)
8347132	Baranoski, Anna M	Instructional	2	Special Education PK-8 (9226)	Instructional 2 Special Education PK-8 (9226)
5973673	Barber, Constance	Instructional	2	Grades PK-4 (2825)	Instructional 2 Grades PK-4 (2825)
5973673	Barber, Constance	Instructional	2	Reading Specialist PK-12 (7650)	Instructional 2 Reading Specialist PK-12 (7650)
8071286	Barger, Tammy M	Instructional	2	General Science 7-12 (8450)	Instructional 2 General Science 7-12 (8450)
6327305	Bargerstock, Whitney E	Instructional	2	Art PK-12 (1405)	Instructional 2 Art PK-12 (1405)
6327305	Bargerstock, Whitney E	Instructional	2	English 7-12 (3230)	Instructional 2 English 7-12 (3230)
6327305	Bargerstock, Whitney E	Supervisory		Supvr Special Education PK-12 (9215)	Supervisory Supvr Special Education PK-12 (9215)
6327305	Bargerstock, Whitney E	Instructional	2	Special Education PK-12 (9225)	Instructional 2 Special Education PK-12 (9225)
8908467	Barney, Christine J	Instructional	2	Social Studies 7-12 (8875)	Instructional 2 Social Studies 7-12 (8875)
7903076	Barney, Dana Jane	Instructional	1	Art PK-12 (1405)	Instructional 1 Art PK-12 (1405)
7903076	Barney, Dana Jane	Instructional	1	English 7-12 (3230)	Instructional 1 English 7-12 (3230)
4590197	Barnhart, Jessica Maria	Instructional	2	Elementary K-6 (2810)	Instructional 2 Elementary K-6 (2810)
4590197	Barnhart, Jessica Maria	Instructional	2	Special Education PK-12 (9225)	Instructional 2 Special Education PK-12 (9225)
2439473	Barrett, Amy L	Instructional	2	Elementary K-6 (2810)	Instructional 2 Elementary K-6 (2810)
2439473	Barrett, Amy L	Instructional	2	Mid-Level Mathematics 6-9 (2860)	Instructional 2 Mid-Level Mathematics 6-9 (2860)
2439473	Barrett, Amy L	Instructional	2	Mid-Level Science 6-9 (2880)	Instructional 2 Mid-Level Science 6-9 (2880)
5029476	Barrett, Kristin D	Instructional	2	Social Studies 7-12 (8875)	Instructional 2 Social Studies 7-12 (8875)
8984271	Barrios, Jennifer A	Educational Specialist	2	Home and School Visitor PK-12 (1850)	Educational Specialist 2 Home and School Visitor PK-12 (1850)
8984271	Barrios, Jennifer A	Educational Specialist	2	School Social Worker PK-12 (1851)	Educational Specialist 2 School Social Worker PK-12 (1851)
6512461	Bartuska, Rebecca Sowa	Educational Specialist	1	Secondary School Counselor 7-12 (1837)	Educational Specialist 1 Secondary School Counselor 7-12 (1837)
6512461	Bartuska, Rebecca Sowa	Instructional	2	Mathematics 7-12 (6800)	Instructional 2 Mathematics 7-12 (6800)
6512461	Bartuska, Rebecca Sowa	Instructional	2	Physics 7-12 (8470)	Instructional 2 Physics 7-12 (8470)
1653853	Bash, Theresa Ann	Instructional	1	Elementary K-6 (2810)	Instructional 1 Elementary K-6 (2810)



State ID	Employee Name	Certificate Type	Level Code	Certificate Description	
1653853	Bash, Theresa Ann	Instructional	1	Special Education PK-8 (9226)	Instructional 1 Special Education PK-8 (9226)
6941361	Basso, Maura J	Instructional	2	Elementary K-6 (2810)	Instructional 2 Elementary K-6 (2810)
6941361	Basso, Maura J	Instructional	2	Special Education PK-12 (9225)	Instructional 2 Special Education PK-12 (9225)
6943929	Baxter, Jenna Laken	Instructional	1	Grades PK-4 (2825)	Instructional 1 Grades PK-4 (2825)
5702327	Bayly, Angela Michelle	Endorsement		Instructional Coach PK-12 (1182)	Endorsement Instructional Coach PK-12 (1182)
5702327	Bayly, Angela Michelle	Instructional	2	Communications 7-12 (3200)	Instructional 2 Communications 7-12 (3200)
5702327	Bayly, Angela Michelle	Instructional	2	English 7-12 (3230)	Instructional 2 English 7-12 (3230)
7318716	Beadle, Karla Marie	Instructional	2	Early Childhood N-3 (2840)	Instructional 2 Early Childhood N-3 (2840)
7318716	Beadle, Karla Marie	Instructional	2	Special Education PK-12 (9225)	Instructional 2 Special Education PK-12 (9225)
5981523	Bedor, Gabrielle Ann	Educational Specialist	1	Inst Technology Specialist PK-12 (1825)	Educational Specialist 1 Inst Technology Specialist PK-12 (1825)
5981523	Bedor, Gabrielle Ann	Instructional	2	English 7-12 (3230)	Instructional 2 English 7-12 (3230)
5981523	Bedor, Gabrielle Ann	Instructional	2	Environmental Educ PK-12 (4820)	Instructional 2 Environmental Educ PK-12 (4820)
5981523	Bedor, Gabrielle Ann	Instructional	2	Technology Education PK-12 (6075)	Instructional 2 Technology Education PK-12 (6075)
5981523	Bedor, Gabrielle Ann	Instructional	2	Biology 7-12 (8405)	Instructional 2 Biology 7-12 (8405)
5981523	Bedor, Gabrielle Ann	Instructional	2	General Science 7-12 (8450)	Instructional 2 General Science 7-12 (8450)
1431604	Beeken, Jennifer A	Instructional	2	English 7-12 (3230)	Instructional 2 English 7-12 (3230)
1431604	Beeken, Jennifer A	Instructional	2	Special Education PK-12 (9225)	Instructional 2 Special Education PK-12 (9225)
4031937	Behm, Haddie Lauren	Instructional	2	Elementary K-6 (2810)	Instructional 2 Elementary K-6 (2810)
4031937	Behm, Haddie Lauren	Instructional	2	Reading Specialist PK-12 (7650)	Instructional 2 Reading Specialist PK-12 (7650)
4031937	Behm, Haddie Lauren	Instructional	2	Special Education PK-12 (9225)	Instructional 2 Special Education PK-12 (9225)
9870941	Berkey, Daniel W	Instructional	2	Technology Education PK-12 (6075)	Instructional 2 Technology Education PK-12 (6075)
9870941	Berkey, Daniel W	Instructional	2	Mathematics 7-12 (6800)	Instructional 2 Mathematics 7-12 (6800)
5978469	Berry, Sharon M	Instructional	2	Elementary K-6 (2810)	Instructional 2 Elementary K-6 (2810)
5978469	Berry, Sharon M	Instructional	2	Mathematics 7-12 (6800)	Instructional 2 Mathematics 7-12 (6800)
3460531	Berstecher, Kelly Ann	Instructional	1	Elementary K-6 (2810)	Instructional 1 Elementary K-6 (2810)
3460531	Berstecher, Kelly Ann	Instructional	1	Ment and/or Phys Handicapped K-12 (9235)	Instructional 1 Ment and/or Phys Handicapped K-12 (9235)
9563287	Beschizza, Heather Grace	Educational Specialist	1	Elementary School Counselor K-6 (1836)	Educational Specialist 1 Elementary School Counselor K-6 (1836)
9563287	Beschizza, Heather Grace	Educational Specialist	1	Secondary School Counselor 7-12 (1837)	Educational Specialist 1 Secondary School Counselor 7-12 (1837)
9563287	Beschizza, Heather Grace	Instructional	1	Elementary K-6 (2810)	Instructional 1 Elementary K-6 (2810)
9563287	Beschizza, Heather Grace	Program Specialist		English as a Second Language (ESL) PK-12 (4499)	Program Specialist English as a Second Language (ESL) PK-12 (4499)
7353271	Bianconi, Heather Ann	Administrative	2	Principal PK-12 (1115)	Administrative 2 Principal PK-12 (1115)
7353271	Bianconi, Heather Ann	Instructional	2	Elementary K-6 (2810)	Instructional 2 Elementary K-6 (2810)
7353271	Bianconi, Heather Ann	Instructional	2	Reading Specialist PK-12 (7650)	Instructional 2 Reading Specialist PK-12 (7650)
3464959	Bilby, Ron J	Instructional	2	Mid-Level Mathematics 6-9 (2860)	Instructional 2 Mid-Level Mathematics 6-9 (2860)
3464959	Bilby, Ron J	Instructional	2	Music PK-12 (7205)	Instructional 2 Music PK-12 (7205)
3031572	Binder, Tawny Norma	Instructional	1	Grades PK-4 (2825)	Instructional 1 Grades PK-4 (2825)
1963475	Bird, Brandon M	Instructional	2	General Science 7-12 (8450)	Instructional 2 General Science 7-12 (8450)
6059381	Boisvert, Jill	Instructional	2	Bus-Computer-Info Tech PK-12 (1603)	Instructional 2 Bus-Computer-Info Tech PK-12 (1603)
6059381	Boisvert, Jill	Private School - Teacher		Mathematics: Sec. Ed. 9-12 (16800)	Private School - Teacher Mathematics: Sec. Ed. 9-12 (16800)
6059381	Boisvert, Jill	Instructional	2	Mathematics 7-12 (6800)	Instructional 2 Mathematics 7-12 (6800)
7269024	Boisvert, Melody Rae	Instructional	1	Grades PK-4 (2825)	Instructional 1 Grades PK-4 (2825)
8459568	Bonniger, Samantha AnnMyers	Instructional	2	Special Education PK-12 (9225)	Instructional 2 Special Education PK-12 (9225)
2832436	Bost, Carissa Marie	Instructional	1	English 7-12 (3230)	Instructional 1 English 7-12 (3230)
2832436	Bost, Carissa Marie	Emergency Permit:		Day-to-Day Sub All Instructional Areas PK-12 (96)	Emergency Permit: Day-to-Day Sub All Instructional Areas PK-12 (96)
9294146	Botti, Michelle	Instructional	1	Grades PK-4 (2825)	Instructional 1 Grades PK-4 (2825)
9294146	Botti, Michelle	Instructional	1	Grades 4-8 (All subjects 4-6 ELA & Reading (3100)	Instructional 1 Grades 4-8 (All subjects 4-6 ELA & Reading (3100)

State ID	Employee Name	Certificate Type	Level Code	Certificate Description	
9294146	Botti, Michelle	Instructional	1	Special Education PK-8 (9226)	Instructional 1 Special Education PK-8 (9226)
1930918	Bowie, Nicole E	Instructional	2	Health & Physical Educ PK-12 (4805)	Instructional 2 Health & Physical Educ PK-12 (4805)
5358072	Boyer, Cathy Marie	Instructional	2	Mathematics 7-12 (6800)	Instructional 2 Mathematics 7-12 (6800)
5358072	Boyer, Cathy Marie	Instructional	2	Special Education PK-12 (9225)	Instructional 2 Special Education PK-12 (9225)
1302864	Boyer, Jessica Leigh	Instructional	2	Elementary K-6 (2810)	Instructional 2 Elementary K-6 (2810)
7018432	Boyle, Jarin Tomas	Instructional	1	Grades PK-4 (2825)	Instructional 1 Grades PK-4 (2825)
8028262	Brand, Catherine	Instructional	1	Elementary K-6 (2810)	Instructional 1 Elementary K-6 (2810)
8028262	Brand, Catherine	Instructional	1	Mid-Level Mathematics 6-9 (2860)	Instructional 1 Mid-Level Mathematics 6-9 (2860)
4295652	Bray, Christopher	Instructional	2	Bus-Computer-Info Tech PK-12 (1603)	Instructional 2 Bus-Computer-Info Tech PK-12 (1603)
4295652	Bray, Christopher	Instructional	2	Elementary K-6 (2810)	Instructional 2 Elementary K-6 (2810)
4295652	Bray, Christopher	Instructional	2	Mid-Level English 6-9 (2850)	Instructional 2 Mid-Level English 6-9 (2850)
4295652	Bray, Christopher	Instructional	2	Mid-Level Citiz. Ed 6-9 (2870)	Instructional 2 Mid-Level Citiz. Ed 6-9 (2870)
4295652	Bray, Christopher	Instructional	2	Mid-Level Science 6-9 (2880)	Instructional 2 Mid-Level Science 6-9 (2880)
4295652	Bray, Christopher	Instructional	2	Family-Consumer Sci PK-12 (5600)	Instructional 2 Family-Consumer Sci PK-12 (5600)
4295652	Bray, Christopher	Instructional	2	Technology Education PK-12 (6075)	Instructional 2 Technology Education PK-12 (6075)
2602809	Brennan, Jean Marie	Instructional	2	Elementary K-6 (2810)	Instructional 2 Elementary K-6 (2810)
8491596	Brestensky, Lisa	Instructional	2	Elementary K-6 (2810)	Instructional 2 Elementary K-6 (2810)
8491596	Brestensky, Lisa	Instructional	2	Ment and/or Phys Handicapped K-12 (9235)	Instructional 2 Ment and/or Phys Handicapped K-12 (9235)
3602713	Breyak, Laurel	Instructional	1	Elementary K-6 (2810)	Instructional 1 Elementary K-6 (2810)
8795053	Briley, Christie Leighann	Instructional	1	Grades PK-4 (2825)	Instructional 1 Grades PK-4 (2825)
3612063	Brisbane, Amber	Instructional	2	Elementary K-6 (2810)	Instructional 2 Elementary K-6 (2810)
3612063	Brisbane, Amber	Instructional	2	Special Education PK-12 (9225)	Instructional 2 Special Education PK-12 (9225)
8308973	Brohi, Heba H	Instructional	2	Elementary K-6 (2810)	Instructional 2 Elementary K-6 (2810)
8308973	Brohi, Heba H	Instructional	2	Mathematics 7-12 (6800)	Instructional 2 Mathematics 7-12 (6800)
8302961	Broniszewski, Diane	Instructional	2	French PK-12 (4410)	Instructional 2 French PK-12 (4410)
8302961	Broniszewski, Diane	Instructional	2	Spanish PK-12 (4490)	Instructional 2 Spanish PK-12 (4490)
8439368	Bronson, Angelica Lauren	Instructional	1	Grades PK-4 (2825)	Instructional 1 Grades PK-4 (2825)
6168378	Brown, Brittany Marie	Endorsement		Autism PK-12 (1180)	Endorsement Autism PK-12 (1180)
6168378	Brown, Brittany Marie	Instructional	1	Grades PK-4 (2825)	Instructional 1 Grades PK-4 (2825)
6168378	Brown, Brittany Marie	Instructional	1	Special Education PK-8 (9226)	Instructional 1 Special Education PK-8 (9226)
8537103	Brown, Kathleen A	Instructional	2	Accounting 7-12 (1610)	Instructional 2 Accounting 7-12 (1610)
8537103	Brown, Kathleen A	Instructional	2	Marketing 7-12 (1640)	Instructional 2 Marketing 7-12 (1640)
8537103	Brown, Kathleen A	Instructional	2	Office Technologies 7-12 (1658)	Instructional 2 Office Technologies 7-12 (1658)
7027624	Brown, Laura Allison	Instructional	1	Elementary K-6 (2810)	Instructional 1 Elementary K-6 (2810)
7027624	Brown, Laura Allison	Instructional	1	Grades PK-4 (2825)	Instructional 1 Grades PK-4 (2825)
2141631	Brown, Sarah C	Instructional	2	Biology 7-12 (8405)	Instructional 2 Biology 7-12 (8405)
2141631	Brown, Sarah C	Instructional	2	Chemistry 7-12 (8420)	Instructional 2 Chemistry 7-12 (8420)
9169278	Brownlie, Victoria Eugenia	Instructional	2	Spanish PK-12 (4490)	Instructional 2 Spanish PK-12 (4490)
1269132	Brucker, Antoinette M	Instructional	2	Special Education PK-12 (9225)	Instructional 2 Special Education PK-12 (9225)
9423031	Bruenn, Matthew J	Instructional	1	Mathematics 7-12 (6800)	Instructional 1 Mathematics 7-12 (6800)
9423031	Bruenn, Matthew J	Instructional	1	Earth and Space Science 7-12 (8440)	Instructional 1 Earth and Space Science 7-12 (8440)
9423031	Bruenn, Matthew J	Instructional	1	General Science 7-12 (8450)	Instructional 1 General Science 7-12 (8450)
6408509	Bryan, Carol L	Instructional	2	Elementary K-6 (2810)	Instructional 2 Elementary K-6 (2810)
6408509	Bryan, Carol L	Instructional	2	Special Education PK-12 (9225)	Instructional 2 Special Education PK-12 (9225)
8360894	Bryson, Jocelyn S	Instructional	2	Elementary K-6 (2810)	Instructional 2 Elementary K-6 (2810)
8360894	Bryson, Jocelyn S	Instructional	2	Special Education PK-12 (9225)	Instructional 2 Special Education PK-12 (9225)

State ID	Employee Name	Certificate Type	Level Code	Certificate Description	
8726136	Buck, Jill	Instructional	1	Elementary K-6 (2810)	Instructional 1 Elementary K-6 (2810)
5038104	Buckwalter, Jodeen E	Instructional	HOUSSE	English 7-12 (3230)	Instructional HOUSSE Designation English 7-12 (3230)
5038104	Buckwalter, Jodeen E	Instructional	HOUSSE	Mathematics 7-12 (6800)	Instructional HOUSSE Designation Mathematics 7-12 (6800)
5038104	Buckwalter, Jodeen E	Instructional	HOUSSE	General Science 7-12 (8450)	Instructional HOUSSE Designation General Science 7-12 (8450)
5038104	Buckwalter, Jodeen E	Instructional	HOUSSE	Social Studies 7-12 (8875)	Instructional HOUSSE Designation Social Studies 7-12 (8875)
5038104	Buckwalter, Jodeen E	Instructional	2	Ment and/or Phys Handicapped K-12 (9235)	Instructional 2 Ment and/or Phys Handicapped K-12 (9235)
1419058	Buffington, Eric G	Administrative	1	Principal PK-12 (1115)	Administrative 1 Principal PK-12 (1115)
1419058	Buffington, Eric G	Instructional	2	Elementary K-6 (2810)	Instructional 2 Elementary K-6 (2810)
1419058	Buffington, Eric G	Instructional	2	Mid-Level Mathematics 6-9 (2860)	Instructional 2 Mid-Level Mathematics 6-9 (2860)
1419058	Buffington, Eric G	Instructional	2	Mid-Level Science 6-9 (2880)	Instructional 2 Mid-Level Science 6-9 (2880)
1419058	Buffington, Eric G	Instructional	2	English 7-12 (3230)	Instructional 2 English 7-12 (3230)
	Bui, Tyler Hung	Instructional	2	Elementary K-6 (2810)	Instructional 2 Elementary K-6 (2810)
	Bunn, Jeffrey H	Instructional	1	Elementary K-6 (2810)	Instructional 1 Elementary K-6 (2810)
5934353	Burke, Jonna Huemrich	Instructional		Elementary K-6 (2810)	Instructional Elementary K-6 (2810)
4703501	Burns, Ashley Elizabeth	Instructional	2	Elementary K-6 (2810)	Instructional 2 Elementary K-6 (2810)
4703501	Burns, Ashley Elizabeth	Instructional	2	Mid-Level English 6-9 (2850)	Instructional 2 Mid-Level English 6-9 (2850)
4703501	Burns, Ashley Elizabeth	Instructional	2	Reading Specialist PK-12 (7650)	Instructional 2 Reading Specialist PK-12 (7650)
5732496	Buss, Jennifer Ann	Instructional	HOUSSE	Elementary K-6 (2810)	Instructional HOUSSE Designation Elementary K-6 (2810)
5732496	Buss, Jennifer Ann	Instructional	2	Special Education PK-12 (9225)	Instructional 2 Special Education PK-12 (9225)
5732496	Buss, Jennifer Ann	Instructional	2	Speech & Language Impaired PK-12 (9265)	Instructional 2 Speech & Language Impaired PK-12 (9265)
1023958	Butera, Maryann	Instructional	1	Elementary K-6 (2810)	Instructional 1 Elementary K-6 (2810)
1023958	Butera, Maryann	Instructional	1	Reading Specialist PK-12 (7650)	Instructional 1 Reading Specialist PK-12 (7650)
1023958	Butera, Maryann	Instructional	1	Special Education PK-12 (9225)	Instructional 1 Special Education PK-12 (9225)
8539581	Butler, Anne M	Instructional	2	Grades PK-4 (2825)	Instructional 2 Grades PK-4 (2825)
8539581	Butler, Anne M	Instructional	2	Grades 4-8 (All subjects 4-6 ELA & Reading (3100)	Instructional 2 Grades 4-8 (All subjects 4-6 ELA & Reading (3100)
8539581	Butler, Anne M	Instructional	2	English 7-12 (3230)	Instructional 2 English 7-12 (3230)
8539581	Butler, Anne M	Instructional	2	Reading Specialist PK-12 (7650)	Instructional 2 Reading Specialist PK-12 (7650)
6028562	Byers, Colien Joanne	Supervisory		Supvr Special Education PK-12 (9215)	Supervisory Supvr Special Education PK-12 (9215)
6028562	Byers, Colien Joanne	Instructional	2	Special Education PK-12 (9225)	Instructional 2 Special Education PK-12 (9225)
2746171	Cadieux, Jennifer	Instructional	1	Special Education PK-12 (9225)	Instructional 1 Special Education PK-12 (9225)
2946235	Cadwallader, Amy Beth	Instructional	2	Mathematics 7-12 (6800)	Instructional 2 Mathematics 7-12 (6800)
8793961	Calton, April Lynne	Instructional	2	Mid-Level Mathematics 6-9 (2860)	Instructional 2 Mid-Level Mathematics 6-9 (2860)
8793961	Calton, April Lynne	Instructional	2	Biology 7-12 (8405)	Instructional 2 Biology 7-12 (8405)
8793961	Calton, April Lynne	Instructional	2	Chemistry 7-12 (8420)	Instructional 2 Chemistry 7-12 (8420)
8793961	Calton, April Lynne	Instructional	2	General Science 7-12 (8450)	Instructional 2 General Science 7-12 (8450)
1524281	Camaioni, Nicole	Instructional	2	Bus-Computer-Info Tech PK-12 (1603)	Instructional 2 Bus-Computer-Info Tech PK-12 (1603)
1524281	Camaioni, Nicole	Instructional	2	English 7-12 (3230)	Instructional 2 English 7-12 (3230)
1524281	Camaioni, Nicole	Instructional	2	Library Science PK-12 (6420)	Instructional 2 Library Science PK-12 (6420)
1524281	Camaioni, Nicole	Instructional	2	Social Studies 7-12 (8875)	Instructional 2 Social Studies 7-12 (8875)
8727359	Camarda, Kate Virginia	Instructional	2	Elementary K-6 (2810)	Instructional 2 Elementary K-6 (2810)
8727359	Camarda, Kate Virginia	Instructional	2	Mid-Level Mathematics 6-9 (2860)	Instructional 2 Mid-Level Mathematics 6-9 (2860)
8727359	Camarda, Kate Virginia	Instructional	2	English 7-12 (3230)	Instructional 2 English 7-12 (3230)
8727359	Camarda, Kate Virginia	Program Specialist		English as a Second Language (ESL) PK-12 (4499)	Program Specialist English as a Second Language (ESL) PK-12 (4499)
1037354	Campbell, Elizabeth Hope	Instructional	1	Grades PK-4 (2825)	Instructional 1 Grades PK-4 (2825)
1037354	Campbell, Elizabeth Hope	Instructional	1	Grades 5-6 (2826)	Instructional 1 Grades 5-6 (2826)
4171219	Canonge, Andrea Lauren	Instructional	1	Elementary K-6 (2810)	Instructional 1 Elementary K-6 (2810)

State ID	Employee Name	Certificate Type	Level Code	Certificate Description	
6989082	Cantwell, Brittney Taylor	Instructional	2	Elementary K-6 (2810)	Instructional 2 Elementary K-6 (2810)
6989082	Cantwell, Brittney Taylor	Instructional	2	Special Education PK-8 (9226)	Instructional 2 Special Education PK-8 (9226)
8981801	Capitano, Jesse C	Instructional	2	Special Education PK-12 (9225)	Instructional 2 Special Education PK-12 (9225)
9813569	Carmichael, Rachel Marie	Instructional	2	Elementary K-6 (2810)	Instructional 2 Elementary K-6 (2810)
9813569	Carmichael, Rachel Marie	Instructional	2	Special Education PK-12 (9225)	Instructional 2 Special Education PK-12 (9225)
5152913	Carr, Jocelyn Rayel	Instructional	2	Elementary K-6 (2810)	Instructional 2 Elementary K-6 (2810)
5152913	Carr, Jocelyn Rayel	Instructional	2	Special Education PK-12 (9225)	Instructional 2 Special Education PK-12 (9225)
2896206	Carver, Jeremy M	Instructional	2	Elementary K-6 (2810)	Instructional 2 Elementary K-6 (2810)
2896206	Carver, Jeremy M	Instructional	2	Mid-Level English 6-9 (2850)	Instructional 2 Mid-Level English 6-9 (2850)
2896206	Carver, Jeremy M	Instructional	2	Mid-Level Mathematics 6-9 (2860)	Instructional 2 Mid-Level Mathematics 6-9 (2860)
2896206	Carver, Jeremy M	Instructional	2	Mid-Level Science 6-9 (2880)	Instructional 2 Mid-Level Science 6-9 (2880)
6739749	Cashman, Sandy	Instructional	1	Elementary K-6 (2810)	Instructional 1 Elementary K-6 (2810)
5696493	Castillon McCarty, Arturo	Instructional	1	Social Studies 7-12 (8875)	Instructional 1 Social Studies 7-12 (8875)
6121506	Center, Tina	Instructional	1	Spanish PK-12 (4490)	Instructional 1 Spanish PK-12 (4490)
9075298	Chaffin, Casey	Instructional	1	Grades PK-4 (2825)	Instructional 1 Grades PK-4 (2825)
9075298	Chaffin, Casey	Instructional	1	Special Education PK-8 (9226)	Instructional 1 Special Education PK-8 (9226)
1861738	Chiado, Nicole Lynn	Instructional	1	Grades PK-4 (2825)	Instructional 1 Grades PK-4 (2825)
1861738	Chiado, Nicole Lynn	Instructional	1	Special Education PK-8 (9226)	Instructional 1 Special Education PK-8 (9226)
5140418	Christmas, Stacy D	Instructional	2	Elementary K-6 (2810)	Instructional 2 Elementary K-6 (2810)
8090325	Ciarlone, Shannon	Instructional	2	Early Childhood N-3 (2840)	Instructional 2 Early Childhood N-3 (2840)
7681605	Clagett, David C	Instructional	2	Social Studies 7-12 (8875)	Instructional 2 Social Studies 7-12 (8875)
7854979	Clark, Susan S	Instructional	2	Reading Specialist PK-12 (7650)	Instructional 2 Reading Specialist PK-12 (7650)
7854979	Clark, Susan S	Instructional	2	Social Studies 7-12 (8875)	Instructional 2 Social Studies 7-12 (8875)
4102713	Cobert, Heather Leann	Instructional	2	Elementary K-6 (2810)	Instructional 2 Elementary K-6 (2810)
4102713	Cobert, Heather Leann	Instructional	2	English 7-12 (3230)	Instructional 2 English 7-12 (3230)
4102713	Cobert, Heather Leann	Instructional	2	Special Education PK-12 (9225)	Instructional 2 Special Education PK-12 (9225)
1928429	Coen, Nicole Lyndsey	Instructional	1	Elementary K-6 (2810)	Instructional 1 Elementary K-6 (2810)
5086528	Compton, Nancy Lee	Educational Specialist	1	School Social Worker PK-12 (1851)	Educational Specialist 1 School Social Worker PK-12 (1851)
5045706	Congdon, Rebekah Lynne	Instructional	HOUSSE	Elementary K-6 (2810)	Instructional HOUSSE Designation Elementary K-6 (2810)
5045706	Congdon, Rebekah Lynne	Instructional	2	Elementary K-6 (2810)	Instructional 2 Elementary K-6 (2810)
5045706	Congdon, Rebekah Lynne	Instructional	2	Ment and/or Phys Handicapped K-12 (9235)	Instructional 2 Ment and/or Phys Handicapped K-12 (9235)
7576873	Connelly, Jennifer Marie	Instructional	2	Elementary K-6 (2810)	Instructional 2 Elementary K-6 (2810)
7576873	Connelly, Jennifer Marie	Instructional	2	Reading Specialist PK-12 (7650)	Instructional 2 Reading Specialist PK-12 (7650)
7576873	Connelly, Jennifer Marie	Instructional	2	Special Education PK-12 (9225)	Instructional 2 Special Education PK-12 (9225)
2614786	Connor, Erin Rose	Instructional	1	Grades PK-4 (2825)	Instructional 1 Grades PK-4 (2825)
2614786	Connor, Erin Rose	Instructional	1	Special Education PK-8 (9226)	Instructional 1 Special Education PK-8 (9226)
9384068	Conway, Meredith Dance	Instructional	2	Elementary K-6 (2810)	Instructional 2 Elementary K-6 (2810)
9384068	Conway, Meredith Dance	Instructional	2	Mid-Level English 6-9 (2850)	Instructional 2 Mid-Level English 6-9 (2850)
9384068	Conway, Meredith Dance	Instructional	2	Mid-Level Mathematics 6-9 (2860)	Instructional 2 Mid-Level Mathematics 6-9 (2860)
9384068	Conway, Meredith Dance	Instructional	2	Mid-Level Science 6-9 (2880)	Instructional 2 Mid-Level Science 6-9 (2880)
9384068	Conway, Meredith Dance	Instructional	2	Special Education PK-12 (9225)	Instructional 2 Special Education PK-12 (9225)
6179747	Cooper, Barbara J	Instructional	2	Elementary K-6 (2810)	Instructional 2 Elementary K-6 (2810)
6179747	Cooper, Barbara J	Instructional	2	Special Education PK-12 (9225)	Instructional 2 Special Education PK-12 (9225)
6341707	Cooper, Laura J	Instructional	1	Elementary K-6 (2810)	Instructional 1 Elementary K-6 (2810)
4679237	Cortes, Alona Jean	Instructional	1	Grades PK-4 (2825)	Instructional 1 Grades PK-4 (2825)
4721493	Costanzo, Kristal	Instructional	2	Elementary K-6 (2810)	Instructional 2 Elementary K-6 (2810)

State ID	Employee Name	Certificate Type	Level Code	Certificate Description	
4721493	Costanzo, Kristal	Instructional	2	Special Education PK-12 (9225)	Instructional 2 Special Education PK-12 (9225)
6364271	Cox, Brianne	Instructional	1	Elementary K-6 (2810)	Instructional 1 Elementary K-6 (2810)
6364271	Cox, Brianne	Instructional	1	Mid-Level Mathematics 6-9 (2860)	Instructional 1 Mid-Level Mathematics 6-9 (2860)
4706023	Coyne, Heather Marie	Instructional	2	Mid-Level Science 6-9 (2880)	Instructional 2 Mid-Level Science 6-9 (2880)
4706023	Coyne, Heather Marie	Instructional	2	Environmental Educ PK-12 (4820)	Instructional 2 Environmental Educ PK-12 (4820)
4706023	Coyne, Heather Marie	Instructional	2	Biology 7-12 (8405)	Instructional 2 Biology 7-12 (8405)
4706023	Coyne, Heather Marie	Instructional	2	General Science 7-12 (8450)	Instructional 2 General Science 7-12 (8450)
7931508	Cragle, Caleb James	Instructional	2	Bus-Computer-Info Tech PK-12 (1603)	Instructional 2 Bus-Computer-Info Tech PK-12 (1603)
7931508	Cragle, Caleb James	Instructional	2	Mid-Level Mathematics 6-9 (2860)	Instructional 2 Mid-Level Mathematics 6-9 (2860)
7931508	Cragle, Caleb James	Instructional	2	Biology 7-12 (8405)	Instructional 2 Biology 7-12 (8405)
7931508	Cragle, Caleb James	Instructional	2	General Science 7-12 (8450)	Instructional 2 General Science 7-12 (8450)
5862824	Cramer, Shila Ellyn	Instructional	2	General Science 7-12 (8450)	Instructional 2 General Science 7-12 (8450)
6282358	Creaven, Melissa	Instructional	2	Elementary K-6 (2810)	Instructional 2 Elementary K-6 (2810)
6282358	Creaven, Melissa	Instructional	2	Early Childhood N-3 (2840)	Instructional 2 Early Childhood N-3 (2840)
1637383	Cross, Amber Faith	Instructional	2	Elementary K-6 (2810)	Instructional 2 Elementary K-6 (2810)
2427256	Cukauskas, Michelle Elizabeth	Private School - Asst or Teacher		Nursery/Kindergarten N-K (12833)	Private School - Asst or Teacher Nursery/Kindergarten N-K (12833)
2427256	Cukauskas, Michelle Elizabeth	Instructional	2	Elementary K-6 (2810)	Instructional 2 Elementary K-6 (2810)
2427256	Cukauskas, Michelle Elizabeth	Supervisory		Supvr Special Education PK-12 (9215)	Supervisory Supvr Special Education PK-12 (9215)
2427256	Cukauskas, Michelle Elizabeth	Instructional	2	Ment and/or Phys Handicapped K-12 (9235)	Instructional 2 Ment and/or Phys Handicapped K-12 (9235)
2804139	Curry, Denise Michele	Endorsement		Instructional Coach PK-12 (1182)	Endorsement Instructional Coach PK-12 (1182)
2804139	Curry, Denise Michele	Private School - Asst or Teacher		Nursery/Kindergarten N-K (12833)	Private School - Asst or Teacher Nursery/Kindergarten N-K (12833)
2804139	Curry, Denise Michele	Instructional	1	Elementary K-6 (2810)	Instructional 1 Elementary K-6 (2810)
2804139	Curry, Denise Michele	Instructional	1	Early Childhood N-3 (2840)	Instructional 1 Early Childhood N-3 (2840)
3672897	Cuviello, Grace	Instructional	1	Grades PK-4 (2825)	Instructional 1 Grades PK-4 (2825)
6943508	Dalessandri-Fetterman, Melissa E	Instructional	2	Elementary K-6 (2810)	Instructional 2 Elementary K-6 (2810)
6943508	Dalessandri-Fetterman, Melissa E	Instructional	2	Special Education PK-12 (9225)	Instructional 2 Special Education PK-12 (9225)
9759372	Dannaker, Doris	Instructional	1	Elementary K-6 (2810)	Instructional 1 Elementary K-6 (2810)
9759372	Dannaker, Doris	Instructional	1	Mid-Level Mathematics 6-9 (2860)	Instructional 1 Mid-Level Mathematics 6-9 (2860)
4867954	Davis, Megan Lynn	Instructional	1	Elementary K-6 (2810)	Instructional 1 Elementary K-6 (2810)
6574183	Davish, Noreen R	Instructional	2	Mid-Level Mathematics 6-9 (2860)	Instructional 2 Mid-Level Mathematics 6-9 (2860)
6574183	Davish, Noreen R	Instructional	2	Music PK-12 (7205)	Instructional 2 Music PK-12 (7205)
6284705	Dearwester, Mia Alexandra	Instructional	1	Reading Specialist PK-12 (7650)	Instructional 1 Reading Specialist PK-12 (7650)
6284705	Dearwester, Mia Alexandra	Instructional	1	Special Education PK-8 (9226)	Instructional 1 Special Education PK-8 (9226)
9328097	Deemer, Judith	Instructional	2	Elementary K-6 (2810)	Instructional 2 Elementary K-6 (2810)
9328097	Deemer, Judith	Instructional	2	Ment and/or Phys Handicapped K-12 (9235)	Instructional 2 Ment and/or Phys Handicapped K-12 (9235)
8072495	Deemer, Melissa Rebecca	Instructional	1	Grades 4-8 (All subjects 4-6 Math 7-8) (3100)	Instructional 1 Grades 4-8 (All subjects 4-6 Math 7-8) (3100)
9562753	DeFelice, Amanda Elaine	Instructional	1	Grades 4-8 (All subjects 4-6 ELA & Reading (3100)	Instructional 1 Grades 4-8 (All subjects 4-6 ELA & Reading (3100)
9562753	DeFelice, Amanda Elaine	Instructional	1	English 7-12 (3230)	Instructional 1 English 7-12 (3230)
6017637	Deloe, Anita J	Instructional	2	Mid-Level Mathematics 6-9 (2860)	Instructional 2 Mid-Level Mathematics 6-9 (2860)
6017637	Deloe, Anita J	Instructional	2	Mid-Level Science 6-9 (2880)	Instructional 2 Mid-Level Science 6-9 (2880)
6017637	Deloe, Anita J	Instructional	2	Safety Ed/Driver Ed 7-12 (5215)	Instructional 2 Safety Ed/Driver Ed 7-12 (5215)
6017637	Deloe, Anita J	Instructional	2	Citizenship 7-12 (8825)	Instructional 2 Citizenship 7-12 (8825)
6017637	Deloe, Anita J	Instructional	2	Social Studies 7-12 (8875)	Instructional 2 Social Studies 7-12 (8875)
5837679	Denham, Angela M	Instructional	2	Elementary K-6 (2810)	Instructional 2 Elementary K-6 (2810)
5837679	Denham, Angela M	Instructional	2	Ment and/or Phys Handicapped K-12 (9235)	Instructional 2 Ment and/or Phys Handicapped K-12 (9235)
1051274	DePietro, Jennifer	Instructional	1	Elementary K-6 (2810)	Instructional 1 Elementary K-6 (2810)

State ID	Employee Name	Certificate Type	Level Code	Certificate Description	
1051274	DePietro, Jennifer	Instructional	1	Early Childhood N-3 (2840)	Instructional 1 Early Childhood N-3 (2840)
1051274	DePietro, Jennifer	Instructional	1	Special Education PK-12 (9225)	Instructional 1 Special Education PK-12 (9225)
2349318	Devine Owen, Erin L	Educational Specialist	2	School Nurse PK-12 (1890)	Educational Specialist 2 School Nurse PK-12 (1890)
6495832	Devinney, Sara O	Private School - Asst or Teacher		Nursery/Kindergarten N-K (12833)	Private School - Asst or Teacher Nursery/Kindergarten N-K (12833)
6495832	Devinney, Sara O	Instructional	2	Art PK-12 (1405)	Instructional 2 Art PK-12 (1405)
6495832	Devinney, Sara O	Instructional	2	Elementary K-6 (2810)	Instructional 2 Elementary K-6 (2810)
6495832	Devinney, Sara O	Instructional	2	Early Childhood N-3 (2840)	Instructional 2 Early Childhood N-3 (2840)
5267479	Di Martini, Danielle J	Private School - Asst or Teacher		Nursery/Kindergarten N-K (12833)	Private School - Asst or Teacher Nursery/Kindergarten N-K (12833)
5267479	Di Martini, Danielle J	Instructional	2	Elementary K-6 (2810)	Instructional 2 Elementary K-6 (2810)
5267479	Di Martini, Danielle J	Instructional	2	Reading Specialist PK-12 (7650)	Instructional 2 Reading Specialist PK-12 (7650)
5267479	Di Martini, Danielle J	Instructional	2	Special Education PK-8 (9226)	Instructional 2 Special Education PK-8 (9226)
4096064	Dietrich, Jenna Lee	Instructional	2	Elementary K-6 (2810)	Instructional 2 Elementary K-6 (2810)
4096064	Dietrich, Jenna Lee	Instructional	2	Special Education PK-12 (9225)	Instructional 2 Special Education PK-12 (9225)
6716134	Dillon, Anne	Instructional	2	English 7-12 (3230)	Instructional 2 English 7-12 (3230)
5841612	Dimov-Gottshall, Emily Marie	Instructional	1	Art PK-12 (1405)	Instructional 1 Art PK-12 (1405)
1051025	DiStefano, Katherine Carole	Instructional	2	Art PK-12 (1405)	Instructional 2 Art PK-12 (1405)
2569601	Dodge, Heidi Marie	Private School - Teacher		Elementary Education K-8 (12810)	Private School - Teacher Elementary Education K-8 (12810)
2569601	Dodge, Heidi Marie	Private School - Asst or Teacher		Nursery/Kindergarten N-K (12833)	Private School - Asst or Teacher Nursery/Kindergarten N-K (12833)
2569601	Dodge, Heidi Marie	Instructional	2	Elementary K-6 (2810)	Instructional 2 Elementary K-6 (2810)
2569601	Dodge, Heidi Marie	Instructional	2	Early Childhood N-3 (2840)	Instructional 2 Early Childhood N-3 (2840)
2569601	Dodge, Heidi Marie	Instructional	2	Special Education PK-12 (9225)	Instructional 2 Special Education PK-12 (9225)
7489562	Doebereiner, Julie Elizabeth	Instructional	2	Special Education PK-12 (9225)	Instructional 2 Special Education PK-12 (9225)
6316362	Donahue, Lindsey Marie	Instructional	2	Grades PK-4 (2825)	Instructional 2 Grades PK-4 (2825)
6316362	Donahue, Lindsey Marie	Instructional	2	Grades 4-8 (All subjects 4-6 ELA & Reading (3100)	Instructional 2 Grades 4-8 (All subjects 4-6 ELA & Reading (3100)
6316362	Donahue, Lindsey Marie	Instructional	2	Reading Specialist PK-12 (7650)	Instructional 2 Reading Specialist PK-12 (7650)
3813891	Donley, Jason M	Instructional	2	Health & Physical Educ PK-12 (4805)	Instructional 2 Health & Physical Educ PK-12 (4805)
9453767	Donnelly, Maureen J	Instructional	2	Mid-Level Mathematics 6-9 (2860)	Instructional 2 Mid-Level Mathematics 6-9 (2860)
9453767	Donnelly, Maureen J	Instructional	2	Mid-Level Science 6-9 (2880)	Instructional 2 Mid-Level Science 6-9 (2880)
9453767	Donnelly, Maureen J	Instructional	2	Earth and Space Science 7-12 (8440)	Instructional 2 Earth and Space Science 7-12 (8440)
9453767	Donnelly, Maureen J	Instructional	2	General Science 7-12 (8450)	Instructional 2 General Science 7-12 (8450)
9764135	Donovan, James M	Clearance		FBI Clearance	Clearance FBI Clearance
6141043	Dorfzaun, Joshua Hiram	Instructional	2	Ment and/or Phys Handicapped K-12 (9235)	Instructional 2 Ment and/or Phys Handicapped K-12 (9235)
8692373	DoVidio, Domenica Rose	Instructional	1	Elementary K-6 (2810)	Instructional 1 Elementary K-6 (2810)
1585189	Draeger, Theresa M	Instructional	1	Elementary K-6 (2810)	Instructional 1 Elementary K-6 (2810)
1585189	Draeger, Theresa M	Instructional	1	Special Education PK-12 (9225)	Instructional 1 Special Education PK-12 (9225)
4018743	Dumas, Jennifer A	Instructional	2	Accounting 7-12 (1610)	Instructional 2 Accounting 7-12 (1610)
4018743	Dumas, Jennifer A	Instructional	2	Data Processing 7-12 (1625)	Instructional 2 Data Processing 7-12 (1625)
4018743	Dumas, Jennifer A	Instructional	2	Marketing 7-12 (1640)	Instructional 2 Marketing 7-12 (1640)
4018743	Dumas, Jennifer A	Instructional	2	Office Technologies 7-12 (1658)	Instructional 2 Office Technologies 7-12 (1658)
3951391	Dunlap, Jill A	Private School - Teacher		Elementary Education K-8 (12810)	Private School - Teacher Elementary Education K-8 (12810)
3951391	Dunlap, Jill A	Private School - Teacher		Soc and Emotionally Dist K-12 (19260)	Private School - Teacher Soc and Emotionally Dist K-12 (19260)
3951391	Dunlap, Jill A	Instructional	2	Elementary K-6 (2810)	Instructional 2 Elementary K-6 (2810)
3951391	Dunlap, Jill A	Instructional	2	Early Childhood N-3 (2840)	Instructional 2 Early Childhood N-3 (2840)
3951391	Dunlap, Jill A	Instructional	HOUSSE	English 7-12 (3230)	Instructional HOUSSE Designation English 7-12 (3230)
3951391	Dunlap, Jill A	Instructional	HOUSSE	Social Studies 7-12 (8875)	Instructional HOUSSE Designation Social Studies 7-12 (8875)
3951391	Dunlap, Jill A	Instructional	2	Special Education PK-12 (9225)	Instructional 2 Special Education PK-12 (9225)

State ID	Employee Name	Certificate Type	Level Code	Certificate Description	
9630187	Dupes, Linda D	Instructional	2	Elementary K-6 (2810)	Instructional 2 Elementary K-6 (2810)
9630187	Dupes, Linda D	Instructional	2	English 7-12 (3230)	Instructional 2 English 7-12 (3230)
5976482	Eberly, Jessica Nicole	Instructional	2	Elementary K-6 (2810)	Instructional 2 Elementary K-6 (2810)
5976482	Eberly, Jessica Nicole	Instructional	2	Early Childhood N-3 (2840)	Instructional 2 Early Childhood N-3 (2840)
1835849	Eckels, Olivia Claire	Instructional	2	Special Education PK-12 (9225)	Instructional 2 Special Education PK-12 (9225)
2169062	Edmundson, Megan Amanda	Instructional	2	English 7-12 (3230)	Instructional 2 English 7-12 (3230)
7032767	Egan, Colleen Denise	Instructional	1	Elementary K-6 (2810)	Instructional 1 Elementary K-6 (2810)
7306241	Eisenhart, GERALYN T	Instructional	2	Elementary K-6 (2810)	Instructional 2 Elementary K-6 (2810)
6167926	Ellis, Bridget Marie	Instructional	2	Elementary K-6 (2810)	Instructional 2 Elementary K-6 (2810)
6167926	Ellis, Bridget Marie	Instructional	2	Special Education PK-12 (9225)	Instructional 2 Special Education PK-12 (9225)
5385905	Elmquist, Dana Lynn	Educational Specialist	1	School Psychologist PK-12 (1875)	Educational Specialist 1 School Psychologist PK-12 (1875)
5385905	Elmquist, Dana Lynn	Instructional	1	Social Studies 7-12 (8875)	Instructional 1 Social Studies 7-12 (8875)
9614984	Emminger, Lauren Louise	Instructional	1	Social Studies 7-12 (8875)	Instructional 1 Social Studies 7-12 (8875)
9614984	Emminger, Lauren Louise	Instructional	1	Special Education 7-12 (9227)	Instructional 1 Special Education 7-12 (9227)
9815743	Emrich, Sherri L	Instructional	2	Elementary K-6 (2810)	Instructional 2 Elementary K-6 (2810)
9815743	Emrich, Sherri L	Instructional	2	Special Education PK-12 (9225)	Instructional 2 Special Education PK-12 (9225)
5403689	Emrick, Carissa Robyn	Instructional	1	Elementary K-6 (2810)	Instructional 1 Elementary K-6 (2810)
5403689	Emrick, Carissa Robyn	Instructional	1	Special Education PK-12 (9225)	Instructional 1 Special Education PK-12 (9225)
1493634	Emsurak, Janeen M	Instructional	2	Elementary K-6 (2810)	Instructional 2 Elementary K-6 (2810)
3848547	Encapera-Teslovich, Joanna	Instructional	2	Elementary K-6 (2810)	Instructional 2 Elementary K-6 (2810)
3848547	Encapera-Teslovich, Joanna	Instructional	2	Mid-Level Mathematics 6-9 (2860)	Instructional 2 Mid-Level Mathematics 6-9 (2860)
3848547	Encapera-Teslovich, Joanna	Instructional	2	Special Education PK-12 (9225)	Instructional 2 Special Education PK-12 (9225)
6278342	England, Emilee Grace	Instructional	1	English 7-12 (3230)	Instructional 1 English 7-12 (3230)
3690615	Erdmann, Melissa	Instructional	2	Elementary K-6 (2810)	Instructional 2 Elementary K-6 (2810)
3690615	Erdmann, Melissa	Instructional	2	Early Childhood N-3 (2840)	Instructional 2 Early Childhood N-3 (2840)
3690615	Erdmann, Melissa	Instructional	2	Mid-Level Mathematics 6-9 (2860)	Instructional 2 Mid-Level Mathematics 6-9 (2860)
3690615	Erdmann, Melissa	Instructional	2	Reading Specialist PK-12 (7650)	Instructional 2 Reading Specialist PK-12 (7650)
8578416	Evangelista, Gina A	Instructional	2	English 7-12 (3230)	Instructional 2 English 7-12 (3230)
8578416	Evangelista, Gina A	Instructional	2	Reading Specialist PK-12 (7650)	Instructional 2 Reading Specialist PK-12 (7650)
6897987	Facciolo, Gina Marie	Instructional	1	Elementary K-6 (2810)	Instructional 1 Elementary K-6 (2810)
2480142	Farster, Ashley Lynne	Instructional	2	Grades PK-4 (2825)	Instructional 2 Grades PK-4 (2825)
2480142	Farster, Ashley Lynne	Instructional	2	Special Education PK-8 (9226)	Instructional 2 Special Education PK-8 (9226)
1607938	Fecik, Justine Lynn	Educational Specialist	1	Elementary School Counselor K-6 (1836)	Educational Specialist 1 Elementary School Counselor K-6 (1836)
1607938	Fecik, Justine Lynn	Educational Specialist	1	Secondary School Counselor 7-12 (1837)	Educational Specialist 1 Secondary School Counselor 7-12 (1837)
1607938	Fecik, Justine Lynn	Instructional	2	Elementary K-6 (2810)	Instructional 2 Elementary K-6 (2810)
1607938	Fecik, Justine Lynn	Instructional	2	Special Education PK-12 (9225)	Instructional 2 Special Education PK-12 (9225)
6131985	Feely, Scott L	Instructional	1	Mid-Level Mathematics 6-9 (2860)	Instructional 1 Mid-Level Mathematics 6-9 (2860)
6131985	Feely, Scott L	Instructional	1	Mid-Level Science 6-9 (2880)	Instructional 1 Mid-Level Science 6-9 (2880)
6131985	Feely, Scott L	Instructional	1	Mathematics 7-12 (6800)	Instructional 1 Mathematics 7-12 (6800)
6131985	Feely, Scott L	Instructional	1	Biology 7-12 (8405)	Instructional 1 Biology 7-12 (8405)
6131985	Feely, Scott L	Instructional	1	General Science 7-12 (8450)	Instructional 1 General Science 7-12 (8450)
8925806	Feeney Hoffmaster, Shannon Margaret	Instructional	2	Social Studies 7-12 (8875)	Instructional 2 Social Studies 7-12 (8875)
8925806	Feeney Hoffmaster, Shannon Margaret	Instructional	2	Special Education PK-12 (9225)	Instructional 2 Special Education PK-12 (9225)
8241017	Fegely, Joy Elaine	Instructional	1	Elementary K-6 (2810)	Instructional 1 Elementary K-6 (2810)
6747158	Feldhaus, Daniel	Instructional	1	Social Studies 7-12 (8875)	Instructional 1 Social Studies 7-12 (8875)
6208603	Ferenchick, Tyler Alexander	Instructional	1	Citizenship 7-12 (8825)	Instructional 1 Citizenship 7-12 (8825)

State ID	Employee Name	Certificate Type	Level Code	Certificate Description	
7497828	Ferguson, Ashley Elizabeth	Instructional	2	Elementary K-6 (2810)	Instructional 2 Elementary K-6 (2810)
7497828	Ferguson, Ashley Elizabeth	Instructional	2	Special Education PK-12 (9225)	Instructional 2 Special Education PK-12 (9225)
6859102	Ferrier, Cassandra L	Instructional	2	Elementary K-6 (2810)	Instructional 2 Elementary K-6 (2810)
6859102	Ferrier, Cassandra L	Instructional	2	English 7-12 (3230)	Instructional 2 English 7-12 (3230)
3536269	Fine, Brianna Lynn	Instructional	1	Grades 4-8 (All subjects 4-6 Math 7-8) (3100)	Instructional 1 Grades 4-8 (All subjects 4-6 Math 7-8) (3100)
9671831	Finlayson, Rosalyn	Endorsement		Online Instruction Program PK-12 (1184)	Endorsement Online Instruction Program PK-12 (1184)
9671831	Finlayson, Rosalyn	Instructional	2	Communications 7-12 (3200)	Instructional 2 Communications 7-12 (3200)
9671831	Finlayson, Rosalyn	Instructional	2	English 7-12 (3230)	Instructional 2 English 7-12 (3230)
9671831	Finlayson, Rosalyn	Program Specialist		English as a Second Language (ESL) PK-12 (4499)	Program Specialist English as a Second Language (ESL) PK-12 (4499)
9671831	Finlayson, Rosalyn	Instructional	2	Reading Specialist PK-12 (7650)	Instructional 2 Reading Specialist PK-12 (7650)
8105219	Fiscus, Grace A	Instructional	2	Grades PK-4 (2825)	Instructional 2 Grades PK-4 (2825)
8105219	Fiscus, Grace A	Instructional	2	Special Education PK-8 (9226)	Instructional 2 Special Education PK-8 (9226)
3576797	Fiscus, Kimberly Ann	Endorsement		Instructional Coach PK-12 (1182)	Endorsement Instructional Coach PK-12 (1182)
3576797	Fiscus, Kimberly Ann	Instructional	2	Special Education 7-12 (9227)	Instructional 2 Special Education 7-12 (9227)
8961729	Fisher Clark, Jennifer Jo	Supervisory		Supvr Special Education PK-12 (9215)	Supervisory Supvr Special Education PK-12 (9215)
8961729	Fisher Clark, Jennifer Jo	Instructional	2	Ment and/or Phys Handicapped K-12 (9235)	Instructional 2 Ment and/or Phys Handicapped K-12 (9235)
7953824	Fitzgerald, Kimberly A	Instructional	2	Elementary K-6 (2810)	Instructional 2 Elementary K-6 (2810)
7953824	Fitzgerald, Kimberly A	Instructional	2	Special Education PK-12 (9225)	Instructional 2 Special Education PK-12 (9225)
3219831	Fitzgibbon, Renee	Instructional	2	Elementary K-6 (2810)	Instructional 2 Elementary K-6 (2810)
3219831	Fitzgibbon, Renee	Instructional	2	Reading Specialist PK-12 (7650)	Instructional 2 Reading Specialist PK-12 (7650)
7192646	Flatley, Jennifer Marie	Instructional	2	Grades PK-4 (2825)	Instructional 2 Grades PK-4 (2825)
7192646	Flatley, Jennifer Marie	Instructional	2	Reading Specialist PK-12 (7650)	Instructional 2 Reading Specialist PK-12 (7650)
7192646	Flatley, Jennifer Marie	Instructional	2	Special Education PK-8 (9226)	Instructional 2 Special Education PK-8 (9226)
7192646	Flatley, Jennifer Marie	Instructional	1	Special Education Expansion 7-12 (9229)	Instructional 1 Special Education Expansion 7-12 (9229)
6978125	Flinchum, Christina Leah	Instructional	2	Social Studies 7-12 (8875)	Instructional 2 Social Studies 7-12 (8875)
5689261	Flores, Kayla Lynn	Instructional	1	Elementary K-6 (2810)	Instructional 1 Elementary K-6 (2810)
5689261	Flores, Kayla Lynn	Instructional	1	Special Education PK-12 (9225)	Instructional 1 Special Education PK-12 (9225)
4891748	Floyd, Michael S	Administrative	1	Secondary Principal 7-12 (1105)	Administrative 1 Secondary Principal 7-12 (1105)
4891748	Floyd, Michael S	Instructional	2	Mid-Level Mathematics 6-9 (2860)	Instructional 2 Mid-Level Mathematics 6-9 (2860)
4891748	Floyd, Michael S	Supervisory	1	Supvr Science 7-12 (8415)	Supervisory 1 Supvr Science 7-12 (8415)
4891748	Floyd, Michael S	Instructional	2	General Science 7-12 (8450)	Instructional 2 General Science 7-12 (8450)
9454898	Folmar, Paul R	Instructional	1	Mathematics 7-12 (6800)	Instructional 1 Mathematics 7-12 (6800)
9454898	Folmar, Paul R	Instructional	1	General Science 7-12 (8450)	Instructional 1 General Science 7-12 (8450)
9454898	Folmar, Paul R	Instructional	1	Physics 7-12 (8470)	Instructional 1 Physics 7-12 (8470)
9571606	Force, Alison Marie	Supervisory		Supvr Curriculum & Inst PK-12 (2915)	Supervisory Supvr Curriculum & Inst PK-12 (2915)
9571606	Force, Alison Marie	Instructional	2	Social Studies 7-12 (8875)	Instructional 2 Social Studies 7-12 (8875)
5620596	Forrest, Emily Christine	Instructional	1	Grades PK-4 (2825)	Instructional 1 Grades PK-4 (2825)
5620596	Forrest, Emily Christine	Instructional	1	Special Education PK-8 (9226)	Instructional 1 Special Education PK-8 (9226)
4904954	Franklin, Melissa Lynn	Instructional	2	Early Childhood N-3 (2840)	Instructional 2 Early Childhood N-3 (2840)
4904954	Franklin, Melissa Lynn	Instructional	2	Special Education PK-12 (9225)	Instructional 2 Special Education PK-12 (9225)
7362847	Franks, Laura E	Instructional	2	Elementary K-6 (2810)	Instructional 2 Elementary K-6 (2810)
7362847	Franks, Laura E	Instructional	2	Special Education PK-12 (9225)	Instructional 2 Special Education PK-12 (9225)
8761485	Frederick, Holly Anne	Letter of Equivalency	1	Master's Equivalency - (1185)	Letter of Equivalency 1 Master's Equivalency - (1185)
8761485	Frederick, Holly Anne	Instructional	2	Grades PK-4 (2825)	Instructional 2 Grades PK-4 (2825)
8761485	Frederick, Holly Anne	Instructional	2	Grades 4-8 (All subjects 4-6 ELA & Reading (3100)	Instructional 2 Grades 4-8 (All subjects 4-6 ELA & Reading (3100)
8761485	Frederick, Holly Anne	Instructional	2	Grades 4-8 (All subjects 4-6 Science 7-8) (3100)	Instructional 2 Grades 4-8 (All subjects 4-6 Science 7-8) (3100)



State ID	Employee Name	Certificate Type	Level Code	Certificate Description	
3523082	Freyvogel Bruss, Colleen L	Administrative	1	Principal PK-12 (1115)	Administrative 1 Principal PK-12 (1115)
3523082	Freyvogel Bruss, Colleen L	Instructional	2	Mid-Level Mathematics 6-9 (2860)	Instructional 2 Mid-Level Mathematics 6-9 (2860)
3523082	Freyvogel Bruss, Colleen L	Instructional	2	Communications 7-12 (3200)	Instructional 2 Communications 7-12 (3200)
3523082	Freyvogel Bruss, Colleen L	Instructional	2	English 7-12 (3230)	Instructional 2 English 7-12 (3230)
3523082	Freyvogel Bruss, Colleen L	Instructional	2	Special Education PK-12 (9225)	Instructional 2 Special Education PK-12 (9225)
5897815	Froehlich, Brittany P	Instructional	2	Elementary K-6 (2810)	Instructional 2 Elementary K-6 (2810)
5897815	Froehlich, Brittany P	Instructional	2	Mid-Level English 6-9 (2850)	Instructional 2 Mid-Level English 6-9 (2850)
5897815	Froehlich, Brittany P	Instructional	2	Special Education PK-12 (9225)	Instructional 2 Special Education PK-12 (9225)
5839145	Furka, David J	Endorsement		Autism PK-12 (1180)	Endorsement Autism PK-12 (1180)
5839145	Furka, David J	Instructional	2	Elementary K-6 (2810)	Instructional 2 Elementary K-6 (2810)
5839145	Furka, David J	Program Specialist		English as a Second Language (ESL) PK-12 (4499)	Program Specialist English as a Second Language (ESL) PK-12 (4499)
5839145	Furka, David J	Instructional	2	Special Education PK-8 (9226)	Instructional 2 Special Education PK-8 (9226)
7959715	Gallagher, Heather Ann	Instructional	2	Elementary K-6 (2810)	Instructional 2 Elementary K-6 (2810)
7959715	Gallagher, Heather Ann	Instructional	2	Special Education PK-12 (9225)	Instructional 2 Special Education PK-12 (9225)
8191468	Gallis, Kimberly Ann	Instructional	2	Elementary K-6 (2810)	Instructional 2 Elementary K-6 (2810)
3606263	Galloway, Kayla Anne	Instructional	1	Elementary K-6 (2810)	Instructional 1 Elementary K-6 (2810)
3031084	Galonski, Morgan M	Endorsement		Instructional Coach PK-12 (1182)	Endorsement Instructional Coach PK-12 (1182)
3031084	Galonski, Morgan M	Instructional	2	Elementary K-6 (2810)	Instructional 2 Elementary K-6 (2810)
3031084	Galonski, Morgan M	Instructional	2	English 7-12 (3230)	Instructional 2 English 7-12 (3230)
3031084	Galonski, Morgan M	Instructional	2	Reading Specialist PK-12 (7650)	Instructional 2 Reading Specialist PK-12 (7650)
9583478	Galonski, Robert B	Private School - Teacher		Biology: Sec. Ed. 9-12 (18405)	Private School - Teacher Biology: Sec. Ed. 9-12 (18405)
9583478	Galonski, Robert B	Instructional	2	Biology 7-12 (8405)	Instructional 2 Biology 7-12 (8405)
9583478	Galonski, Robert B	Instructional	2	General Science 7-12 (8450)	Instructional 2 General Science 7-12 (8450)
2806325	Gannon, Devin Richard	Instructional	1	Elementary K-6 (2810)	Instructional 1 Elementary K-6 (2810)
2806325	Gannon, Devin Richard	Instructional	1	Special Education PK-12 (9225)	Instructional 1 Special Education PK-12 (9225)
1673067	Ganter, Crysta M	Instructional	2	Grades PK-4 (2825)	Instructional 2 Grades PK-4 (2825)
1673067	Ganter, Crysta M	Instructional	2	Grades 5-6 (2826)	Instructional 2 Grades 5-6 (2826)
1673067	Ganter, Crysta M	Instructional	2	Special Education PK-8 (9226)	Instructional 2 Special Education PK-8 (9226)
8048158	Garczynski, Molly E	Private School - Asst or Teacher		Nursery/Kindergarten N-K (12833)	Private School - Asst or Teacher Nursery/Kindergarten N-K (12833)
8048158	Garczynski, Molly E	Instructional	2	Elementary K-6 (2810)	Instructional 2 Elementary K-6 (2810)
8048158	Garczynski, Molly E	Instructional	2	Special Education PK-12 (9225)	Instructional 2 Special Education PK-12 (9225)
1678431	Gasos, Melissa	Private School - Teacher		Soc and Emotionally Dist K-12 (19260)	Private School - Teacher Soc and Emotionally Dist K-12 (19260)
1678431	Gasos, Melissa	Instructional	2	Special Education PK-12 (9225)	Instructional 2 Special Education PK-12 (9225)
5748249	Gaylord, Callie A	Instructional	2	English 7-12 (3230)	Instructional 2 English 7-12 (3230)
4609487	Geiman, Amanda Mae	Instructional	2	Elementary K-6 (2810)	Instructional 2 Elementary K-6 (2810)
5301637	George, Michelle Beatrice	Instructional	1	Elementary K-6 (2810)	Instructional 1 Elementary K-6 (2810)
4686739	Gibbons, Ahrin Yvette	Instructional	1	General Science 7-12 (8450)	Instructional 1 General Science 7-12 (8450)
9589157	Giordano, Kathryn	Educational Specialist	2	School Psychologist PK-12 (1875)	Educational Specialist 2 School Psychologist PK-12 (1875)
9589157	Giordano, Kathryn	Instructional	1	Elementary K-6 (2810)	Instructional 1 Elementary K-6 (2810)
3543801	Giovanisci, Katy Veronica	Administrative	1	Principal PK-12 (1115)	Administrative 1 Principal PK-12 (1115)
3543801	Giovanisci, Katy Veronica	Supervisory	1	Supvr Curriculum & Inst PK-12 (2915)	Supervisory 1 Supvr Curriculum & Inst PK-12 (2915)
3543801	Giovanisci, Katy Veronica	Instructional	2	Communications 7-12 (3200)	Instructional 2 Communications 7-12 (3200)
3543801	Giovanisci, Katy Veronica	Instructional	2	English 7-12 (3230)	Instructional 2 English 7-12 (3230)
4529215	Girard, Karen Danielle	Instructional	2	Elementary K-6 (2810)	Instructional 2 Elementary K-6 (2810)
4529215	Girard, Karen Danielle	Instructional	2	Ment and/or Phys Handicapped K-12 (9235)	Instructional 2 Ment and/or Phys Handicapped K-12 (9235)
2102439	Goff, Jaelynne Beeler	Instructional	1	English 7-12 (3230)	Instructional 1 English 7-12 (3230)

State ID	Employee Name	Certificate Type	Level Code	Certificate Description	
2102439	Goff, Jaelynne Beeler	Instructional	1	Social Studies 7-12 (8875)	Instructional 1 Social Studies 7-12 (8875)
1020343	Goughnour, Lauren Marie	Instructional	2	Mathematics 7-12 (6800)	Instructional 2 Mathematics 7-12 (6800)
9278058	Grafton, Brittany Alice	Instructional	1	Grades PK-4 (2825)	Instructional 1 Grades PK-4 (2825)
9278058	Grafton, Brittany Alice	Instructional	1	Special Education PK-8 (9226)	Instructional 1 Special Education PK-8 (9226)
9278058	Grafton, Brittany Alice	Instructional	1	Special Education Expansion 7-12 (9229)	Instructional 1 Special Education Expansion 7-12 (9229)
6326152	Grant, Jamie Marie	Endorsement		Instructional Coach PK-12 (1182)	Endorsement Instructional Coach PK-12 (1182)
6326152	Grant, Jamie Marie	Instructional	2	Elementary K-6 (2810)	Instructional 2 Elementary K-6 (2810)
5914803	Gravelly, Angelique Iyabo	Educational Specialist	1	Elem. & Secondary School Counselor PK-12 (1839)	Educational Specialist 1 Elem. & Secondary School Counselor PK-12
2809767	Griffith, Dean A	Instructional	2	General Science 7-12 (8450)	Instructional 2 General Science 7-12 (8450)
2809767	Griffith, Dean A	Instructional	2	Social Studies 7-12 (8875)	Instructional 2 Social Studies 7-12 (8875)
8767092	Gruber, Jenna Bertele	Instructional	1	Art PK-12 (1405)	Instructional 1 Art PK-12 (1405)
4540246	Gruszewski, Amanda Marie	Instructional	1	Grades PK-4 (2825)	Instructional 1 Grades PK-4 (2825)
4540246	Gruszewski, Amanda Marie	Instructional	1	Family-Consumer Sci PK-12 (5600)	Instructional 1 Family-Consumer Sci PK-12 (5600)
4540246	Gruszewski, Amanda Marie	Instructional	1	Special Education PK-8 (9226)	Instructional 1 Special Education PK-8 (9226)
4540246	Gruszewski, Amanda Marie	Instructional	1	Special Education 7-12 (9227)	Instructional 1 Special Education 7-12 (9227)
6934056	Gussow, Steven M	Instructional	2	Mathematics 7-12 (6800)	Instructional 2 Mathematics 7-12 (6800)
1563801	Guyer, Melissa Miller	Letter of Equivalency		Master's Equivalency - (1185)	Letter of Equivalency Master's Equivalency - (1185)
1563801	Guyer, Melissa Miller	Educational Specialist	1	Secondary School Counselor 7-12 (1837)	Educational Specialist 1 Secondary School Counselor 7-12 (1837)
1563801	Guyer, Melissa Miller	Educational Specialist	2	Secondary School Counselor 7-12 (1837)	Educational Specialist 2 Secondary School Counselor 7-12 (1837)
1563801	Guyer, Melissa Miller	Instructional	2	Mid-Level English 6-9 (2850)	Instructional 2 Mid-Level English 6-9 (2850)
1563801	Guyer, Melissa Miller	Instructional	2	Social Studies 7-12 (8875)	Instructional 2 Social Studies 7-12 (8875)
3567816	Hadley, Lynn	Instructional	2	Bus-Computer-Info Tech PK-12 (1603)	Instructional 2 Bus-Computer-Info Tech PK-12 (1603)
3567816	Hadley, Lynn	Instructional	2	Social Studies 7-12 (8875)	Instructional 2 Social Studies 7-12 (8875)
1813936	Hagelgans, Matthew J	Instructional	1	Social Studies 7-12 (8875)	Instructional 1 Social Studies 7-12 (8875)
2749242	Hale-Patterson, Melissa P	Endorsement		Instructional Coach PK-12 (1182)	Endorsement Instructional Coach PK-12 (1182)
2749242	Hale-Patterson, Melissa P	Instructional	2	Elementary K-6 (2810)	Instructional 2 Elementary K-6 (2810)
2749242	Hale-Patterson, Melissa P	Instructional	2	Special Education PK-12 (9225)	Instructional 2 Special Education PK-12 (9225)
1087343	Hamburger, Karen Marie	Instructional	2	Elementary K-6 (2810)	Instructional 2 Elementary K-6 (2810)
1087343	Hamburger, Karen Marie	Instructional	2	Mid-Level Mathematics 6-9 (2860)	Instructional 2 Mid-Level Mathematics 6-9 (2860)
7090607	Haney-Filippone, Heather Jo	Instructional	1	Elementary K-6 (2810)	Instructional 1 Elementary K-6 (2810)
7090607	Haney-Filippone, Heather Jo	Instructional	1	Grades PK-4 (2825)	Instructional 1 Grades PK-4 (2825)
7090607	Haney-Filippone, Heather Jo	Instructional	1	Special Education PK-8 (9226)	Instructional 1 Special Education PK-8 (9226)
4760385	Harbaugh, Amanda Blair	Instructional	2	Elementary K-6 (2810)	Instructional 2 Elementary K-6 (2810)
4760385	Harbaugh, Amanda Blair	Instructional	2	Mid-Level English 6-9 (2850)	Instructional 2 Mid-Level English 6-9 (2850)
9108013	Hardisky, Jennifer Rebecca	Instructional	1	Biology 7-12 (8405)	Instructional 1 Biology 7-12 (8405)
2598387	Hardy, Emily Elizabeth	Instructional	1	Grades PK-4 (2825)	Instructional 1 Grades PK-4 (2825)
2598387	Hardy, Emily Elizabeth	Instructional	1	Special Education PK-8 (9226)	Instructional 1 Special Education PK-8 (9226)
8262939	Harkins, Paul K	Administrative	1	Principal PK-12 (1115)	Administrative 1 Principal PK-12 (1115)
8262939	Harkins, Paul K	Instructional	2	English 7-12 (3230)	Instructional 2 English 7-12 (3230)
8209824	Harlan, Maria	Instructional	2	Elementary K-6 (2810)	Instructional 2 Elementary K-6 (2810)
8209824	Harlan, Maria	Instructional	2	Special Education PK-8 (9226)	Instructional 2 Special Education PK-8 (9226)
3408636	Harris, Tracy E	Instructional	2	Elementary K-6 (2810)	Instructional 2 Elementary K-6 (2810)
3408636	Harris, Tracy E	Instructional	2	Mid-Level Mathematics 6-9 (2860)	Instructional 2 Mid-Level Mathematics 6-9 (2860)
3408636	Harris, Tracy E	Instructional	2	Reading Specialist PK-12 (7650)	Instructional 2 Reading Specialist PK-12 (7650)
9387058	Hartlep, Tara R	Instructional	2	Elementary K-6 (2810)	Instructional 2 Elementary K-6 (2810)
9387058	Hartlep, Tara R	Instructional	2	Mid-Level English 6-9 (2850)	Instructional 2 Mid-Level English 6-9 (2850)

State ID	Employee Name	Certificate Type	Level Code	Certificate Description	
9387058	Hartlep, Tara R	Instructional	2	Mid-Level Mathematics 6-9 (2860)	Instructional 2 Mid-Level Mathematics 6-9 (2860)
9387058	Hartlep, Tara R	Program Specialist		English as a Second Language (ESL) PK-12 (4499)	Program Specialist English as a Second Language (ESL) PK-12 (4499)
3606539	Hartman, Cathrine S	Instructional	1	Grades PK-4 (2825)	Instructional 1 Grades PK-4 (2825)
3606539	Hartman, Cathrine S	Instructional	1	Special Education PK-8 (9226)	Instructional 1 Special Education PK-8 (9226)
7359613	Hartman, Robin E	Instructional	2	Elementary K-6 (2810)	Instructional 2 Elementary K-6 (2810)
8407809	Harvey, Barbara N	Private School - Teacher		Elementary Education K-8 (12810)	Private School - Teacher Elementary Education K-8 (12810)
8407809	Harvey, Barbara N	Private School - Teacher		Mathematics: Sec. Ed. 9-12 (16800)	Private School - Teacher Mathematics: Sec. Ed. 9-12 (16800)
8407809	Harvey, Barbara N	Private School - Teacher		Mentally Retarded K-12 (19220)	Private School - Teacher Mentally Retarded K-12 (19220)
8407809	Harvey, Barbara N	Private School - Teacher		Physically Handicapped K-12 (19240)	Private School - Teacher Physically Handicapped K-12 (19240)
8407809	Harvey, Barbara N	Private School - Teacher		Learning Disabled K-12 (19245)	Private School - Teacher Learning Disabled K-12 (19245)
8407809	Harvey, Barbara N	Private School - Teacher		Soc and Emotionally Dist K-12 (19260)	Private School - Teacher Soc and Emotionally Dist K-12 (19260)
8407809	Harvey, Barbara N	Instructional	2	Elementary K-6 (2810)	Instructional 2 Elementary K-6 (2810)
8407809	Harvey, Barbara N	Instructional	2	Mid-Level English 6-9 (2850)	Instructional 2 Mid-Level English 6-9 (2850)
8407809	Harvey, Barbara N	Instructional	2	Mid-Level Mathematics 6-9 (2860)	Instructional 2 Mid-Level Mathematics 6-9 (2860)
8407809	Harvey, Barbara N	Instructional	2	Mid-Level Citiz. Ed 6-9 (2870)	Instructional 2 Mid-Level Citiz. Ed 6-9 (2870)
8407809	Harvey, Barbara N	Supervisory		Supvr Special Education PK-12 (9215)	Supervisory Supvr Special Education PK-12 (9215)
8407809	Harvey, Barbara N	Instructional	2	Ment and/or Phys Handicapped K-12 (9235)	Instructional 2 Ment and/or Phys Handicapped K-12 (9235)
7142391	Hathaway, Melanie Lynn	Educational Specialist	1	Inst Technology Specialist PK-12 (1825)	Educational Specialist 1 Inst Technology Specialist PK-12 (1825)
7142391	Hathaway, Melanie Lynn	Instructional	2	Elementary K-6 (2810)	Instructional 2 Elementary K-6 (2810)
7142391	Hathaway, Melanie Lynn	Instructional	2	Early Childhood N-3 (2840)	Instructional 2 Early Childhood N-3 (2840)
7142391	Hathaway, Melanie Lynn	Instructional	2	Family-Consumer Sci PK-12 (5600)	Instructional 2 Family-Consumer Sci PK-12 (5600)
7142391	Hathaway, Melanie Lynn	Instructional	2	Special Education PK-8 (9226)	Instructional 2 Special Education PK-8 (9226)
5475409	Hawk, Kristie	Administrative		Principal PK-12 (1115)	Administrative Principal PK-12 (1115)
5475409	Hawk, Kristie	Instructional	2	Art PK-12 (1405)	Instructional 2 Art PK-12 (1405)
1089065	Heard, Pamela Ann	Letter of Equivalency		Master's Equivalency - (1185)	Letter of Equivalency Master's Equivalency - (1185)
1089065	Heard, Pamela Ann	Instructional	2	Health & Physical Educ PK-12 (4805)	Instructional 2 Health & Physical Educ PK-12 (4805)
1089065	Heard, Pamela Ann	Instructional	2	Safety Ed/Driver Ed 7-12 (5215)	Instructional 2 Safety Ed/Driver Ed 7-12 (5215)
8167832	Hennig, Ashley Nicole	Instructional	2	Mathematics 7-12 (6800)	Instructional 2 Mathematics 7-12 (6800)
1872897	Henretta, Erikka Ann	Instructional	1	Grades PK-4 (2825)	Instructional 1 Grades PK-4 (2825)
1872897	Henretta, Erikka Ann	Instructional	1	Special Education PK-8 (9226)	Instructional 1 Special Education PK-8 (9226)
7694718	Henriquez, Ibis Raquel	Instructional	1	Spanish PK-12 (4490)	Instructional 1 Spanish PK-12 (4490)
7315086	Heppenstall, Amber Paige	Instructional	1	Grades PK-4 (2825)	Instructional 1 Grades PK-4 (2825)
7315086	Heppenstall, Amber Paige	Instructional	1	Special Education PK-8 (9226)	Instructional 1 Special Education PK-8 (9226)
2079054	Hetrick, Angela Mae	Instructional	2	Social Studies 7-12 (8875)	Instructional 2 Social Studies 7-12 (8875)
9482165	Hewitt, Denna Marcell	Administrative	1	Principal PK-12 (1115)	Administrative 1 Principal PK-12 (1115)
9482165	Hewitt, Denna Marcell	Instructional	2	English 7-12 (3230)	Instructional 2 English 7-12 (3230)
9482165	Hewitt, Denna Marcell	Instructional	2	Special Education PK-12 (9225)	Instructional 2 Special Education PK-12 (9225)
1463905	Hill, Jessica Ann	Instructional	2	Elementary K-6 (2810)	Instructional 2 Elementary K-6 (2810)
6586245	Hill, Lisa M	Instructional	2	Elementary K-6 (2810)	Instructional 2 Elementary K-6 (2810)
6586245	Hill, Lisa M	Instructional	2	Early Childhood N-3 (2840)	Instructional 2 Early Childhood N-3 (2840)
6586245	Hill, Lisa M	Instructional	2	Reading Specialist PK-12 (7650)	Instructional 2 Reading Specialist PK-12 (7650)
6208696	Hill, Ocie	Instructional	2	English 7-12 (3230)	Instructional 2 English 7-12 (3230)
6208696	Hill, Ocie	Instructional	2	Social Studies 7-12 (8875)	Instructional 2 Social Studies 7-12 (8875)
6208696	Hill, Ocie	Instructional	2	Special Education PK-12 (9225)	Instructional 2 Special Education PK-12 (9225)
5430368	Hilson, Erin R	Administrative	1	Principal PK-12 (1115)	Administrative 1 Principal PK-12 (1115)
5430368	Hilson, Erin R	Instructional	1	Reading Specialist PK-12 (7650)	Instructional 1 Reading Specialist PK-12 (7650)

State ID	Employee Name	Certificate Type	Level Code	Certificate Description	
5430368	Hilson, Erin R	Instructional	1	Special Education PK-12 (9225)	Instructional 1 Special Education PK-12 (9225)
2026704	Hoff, Rachel Lynn	Instructional	1	Library Science PK-12 (6420)	Instructional 1 Library Science PK-12 (6420)
5893439	Hoffman Long, Melissa R	Instructional	2	Environmental Educ PK-12 (4820)	Instructional 2 Environmental Educ PK-12 (4820)
5893439	Hoffman Long, Melissa R	Instructional	2	Biology 7-12 (8405)	Instructional 2 Biology 7-12 (8405)
5371396	Hoffman, Kaelyn McKenzie	Instructional	1	Grades PK-4 (2825)	Instructional 1 Grades PK-4 (2825)
5371396	Hoffman, Kaelyn McKenzie	Instructional	1	Grades 4-8 (All subjects 4-6 ELA & Reading (3100)	Instructional 1 Grades 4-8 (All subjects 4-6 ELA & Reading (3100)
5371396	Hoffman, Kaelyn McKenzie	Instructional	1	Special Education PK-8 (9226)	Instructional 1 Special Education PK-8 (9226)
5176786	Hollenbach, Nicolette Marie	Instructional	2	Elementary K-6 (2810)	Instructional 2 Elementary K-6 (2810)
5176786	Hollenbach, Nicolette Marie	Instructional	2	Special Education PK-12 (9225)	Instructional 2 Special Education PK-12 (9225)
2476895	Holton, Joanna F	Instructional	2	Reading Specialist PK-12 (7650)	Instructional 2 Reading Specialist PK-12 (7650)
2476895	Holton, Joanna F	Instructional	2	Special Education PK-12 (9225)	Instructional 2 Special Education PK-12 (9225)
1038684	Hopkins, Ellen P	Instructional	2	Elementary K-6 (2810)	Instructional 2 Elementary K-6 (2810)
1038684	Hopkins, Ellen P	Instructional	2	Reading Specialist PK-12 (7650)	Instructional 2 Reading Specialist PK-12 (7650)
7461641	Hornbake, Jansen L	Administrative	2	Principal PK-12 (1115)	Administrative 2 Principal PK-12 (1115)
7461641	Hornbake, Jansen L	Instructional	2	Elementary K-6 (2810)	Instructional 2 Elementary K-6 (2810)
7461641	Hornbake, Jansen L	Supervisory		Supvr Curriculum & Inst PK-12 (2915)	Supervisory Supvr Curriculum & Inst PK-12 (2915)
8945741	Horst, Nicole Elizabeth	Instructional	2	Elementary K-6 (2810)	Instructional 2 Elementary K-6 (2810)
8945741	Horst, Nicole Elizabeth	Program Specialist		English as a Second Language (ESL) PK-12 (4499)	Program Specialist English as a Second Language (ESL) PK-12 (4499)
4049892	Horton, Danielle R	Instructional	2	Bus-Computer-Info Tech PK-12 (1603)	Instructional 2 Bus-Computer-Info Tech PK-12 (1603)
4049892	Horton, Danielle R	Program Specialist		English as a Second Language (ESL) PK-12 (4499)	Program Specialist English as a Second Language (ESL) PK-12 (4499)
5474193	Houck, Jessica Marie	Instructional	1	Grades PK-4 (2825)	Instructional 1 Grades PK-4 (2825)
5964816	Houseknecht, Dayna S	Instructional	2	Elementary K-6 (2810)	Instructional 2 Elementary K-6 (2810)
5964816	Houseknecht, Dayna S	Instructional	2	Mid-Level English 6-9 (2850)	Instructional 2 Mid-Level English 6-9 (2850)
5964816	Houseknecht, Dayna S	Instructional	2	Mid-Level Citiz. Ed 6-9 (2870)	Instructional 2 Mid-Level Citiz. Ed 6-9 (2870)
3105632	Howe, Erin M	Instructional	2	Elementary K-6 (2810)	Instructional 2 Elementary K-6 (2810)
3105632	Howe, Erin M	Instructional	2	Mid-Level English 6-9 (2850)	Instructional 2 Mid-Level English 6-9 (2850)
3105632	Howe, Erin M	Instructional	2	Mid-Level Mathematics 6-9 (2860)	Instructional 2 Mid-Level Mathematics 6-9 (2860)
3274058	Huff, Ashley N	Instructional	2	Elementary K-6 (2810)	Instructional 2 Elementary K-6 (2810)
7165636	Huffman, Jena Mae	Instructional	2	Elementary K-6 (2810)	Instructional 2 Elementary K-6 (2810)
7165636	Huffman, Jena Mae	Instructional	2	Mid-Level Mathematics 6-9 (2860)	Instructional 2 Mid-Level Mathematics 6-9 (2860)
7165636	Huffman, Jena Mae	Instructional	2	Special Education PK-12 (9225)	Instructional 2 Special Education PK-12 (9225)
3547971	Humanick, Kymberly Diana	Instructional	2	Elementary K-6 (2810)	Instructional 2 Elementary K-6 (2810)
3547971	Humanick, Kymberly Diana	Program Specialist		English as a Second Language (ESL) PK-12 (4499)	Program Specialist English as a Second Language (ESL) PK-12 (4499)
3547971	Humanick, Kymberly Diana	Instructional	2	Special Education PK-12 (9225)	Instructional 2 Special Education PK-12 (9225)
7871924	Hunkele, Terri Lee	Instructional	2	Elementary K-6 (2810)	Instructional 2 Elementary K-6 (2810)
7871924	Hunkele, Terri Lee	Instructional	2	Special Education PK-12 (9225)	Instructional 2 Special Education PK-12 (9225)
5056734	Hunt, Jocelyn Diane	Instructional	1	Elementary K-6 (2810)	Instructional 1 Elementary K-6 (2810)
5420463	Iampietro, Jared A	Instructional	2	Biology 7-12 (8405)	Instructional 2 Biology 7-12 (8405)
1827494	Imbarlina, Cindy	Letter of Equivalency		Master's Equivalency - (1185)	Letter of Equivalency Master's Equivalency - (1185)
1827494	Imbarlina, Cindy	Instructional	2	Elementary K-6 (2810)	Instructional 2 Elementary K-6 (2810)
1827494	Imbarlina, Cindy	Instructional	2	Ment and/or Phys Handicapped K-12 (9235)	Instructional 2 Ment and/or Phys Handicapped K-12 (9235)
9456021	Jackson, Erin L	Administrative		Principal PK-12 (1115)	Administrative Principal PK-12 (1115)
9456021	Jackson, Erin L	Instructional	2	French PK-12 (4410)	Instructional 2 French PK-12 (4410)
6139372	Jackson, Veronica A	Instructional	2	Elementary K-6 (2810)	Instructional 2 Elementary K-6 (2810)
6139372	Jackson, Veronica A	Instructional	2	Ment and/or Phys Handicapped K-12 (9235)	Instructional 2 Ment and/or Phys Handicapped K-12 (9235)
4791514	Jacob, Linda Michelle	Instructional	1	Elementary K-6 (2810)	Instructional 1 Elementary K-6 (2810)

State ID	Employee Name	Certificate Type	Level Code	Certificate Description	
7875193	Jafarian, Mia N	Educational Specialist	2	Secondary School Counselor 7-12 (1837)	Educational Specialist 2 Secondary School Counselor 7-12 (1837)
3584764	Jensen, Richard S	Administrative	2	Principal PK-12 (1115)	Administrative 2 Principal PK-12 (1115)
3584764	Jensen, Richard S	Instructional	2	Social Studies 7-12 (8875)	Instructional 2 Social Studies 7-12 (8875)
4834051	Jimenez Brodie, Elinore	Instructional	2	Elementary K-6 (2810)	Instructional 2 Elementary K-6 (2810)
4834051	Jimenez Brodie, Elinore	Instructional	2	Spanish PK-12 (4490)	Instructional 2 Spanish PK-12 (4490)
9682934	Johnson, Maryann	Administrative	1	Principal PK-12 (1115)	Administrative 1 Principal PK-12 (1115)
9682934	Johnson, Maryann	Instructional	2	Elementary K-6 (2810)	Instructional 2 Elementary K-6 (2810)
9682934	Johnson, Maryann	Supervisory		Supvr Special Education PK-12 (9215)	Supervisory Supvr Special Education PK-12 (9215)
9682934	Johnson, Maryann	Instructional	2	Special Education PK-12 (9225)	Instructional 2 Special Education PK-12 (9225)
1846798	Johnson-Nied, Caitlin	Instructional	2	Elementary K-6 (2810)	Instructional 2 Elementary K-6 (2810)
1846798	Johnson-Nied, Caitlin	Instructional	2	Early Childhood N-3 (2840)	Instructional 2 Early Childhood N-3 (2840)
1846798	Johnson-Nied, Caitlin	Instructional	2	Mid-Level English 6-9 (2850)	Instructional 2 Mid-Level English 6-9 (2850)
1846798	Johnson-Nied, Caitlin	Instructional	2	Mid-Level Mathematics 6-9 (2860)	Instructional 2 Mid-Level Mathematics 6-9 (2860)
2586973	Johnston, Jennifer A	Instructional	1	Elementary K-6 (2810)	Instructional 1 Elementary K-6 (2810)
3575206	Jones, Gabrielle Saracino	Instructional	2	Elementary K-6 (2810)	Instructional 2 Elementary K-6 (2810)
3575206	Jones, Gabrielle Saracino	Instructional	2	English 7-12 (3230)	Instructional 2 English 7-12 (3230)
3575206	Jones, Gabrielle Saracino	Instructional	2	Special Education PK-12 (9225)	Instructional 2 Special Education PK-12 (9225)
7465124	Joseph, Margret Rene	Instructional	2	Elementary K-6 (2810)	Instructional 2 Elementary K-6 (2810)
7465124	Joseph, Margret Rene	Instructional	2	English 7-12 (3230)	Instructional 2 English 7-12 (3230)
7465124	Joseph, Margret Rene	Instructional	2	Special Education PK-12 (9225)	Instructional 2 Special Education PK-12 (9225)
3765736	Jusko, Melissa Maria	Instructional	1	Art PK-12 (1405)	Instructional 1 Art PK-12 (1405)
2010834	Kammermeier, Amanda	Instructional	1	Early Childhood N-3 (2840)	Instructional 1 Early Childhood N-3 (2840)
2010834	Kammermeier, Amanda	Instructional	1	Special Education PK-8 (9226)	Instructional 1 Special Education PK-8 (9226)
2010834	Kammermeier, Amanda	Instructional	1	Special Education Expansion 7-12 (9229)	Instructional 1 Special Education Expansion 7-12 (9229)
4156178	Kara, Rebecca J	Instructional	2	Elementary K-6 (2810)	Instructional 2 Elementary K-6 (2810)
8940986	Karosas, Lisa Marie	Instructional	2	Mid-Level Science 6-9 (2880)	Instructional 2 Mid-Level Science 6-9 (2880)
8940986	Karosas, Lisa Marie	Instructional	2	Chemistry 7-12 (8420)	Instructional 2 Chemistry 7-12 (8420)
8304964	Karp, Barbara Myers	Instructional	2	Elementary K-6 (2810)	Instructional 2 Elementary K-6 (2810)
8304964	Karp, Barbara Myers	Instructional	2	Social Studies 7-12 (8875)	Instructional 2 Social Studies 7-12 (8875)
7598317	Kaufman, Gillian Spencer	Instructional	2	Grades PK-4 (2825)	Instructional 2 Grades PK-4 (2825)
7598317	Kaufman, Gillian Spencer	Instructional	2	Special Education PK-8 (9226)	Instructional 2 Special Education PK-8 (9226)
7598317	Kaufman, Gillian Spencer	Instructional	1	Special Education 7-12 (9227)	Instructional 1 Special Education 7-12 (9227)
1052491	Kaufman, Melissa Lynn	Instructional	2	Elementary K-6 (2810)	Instructional 2 Elementary K-6 (2810)
9625157	Keck, Marianne Christine	Instructional	2	Biology 7-12 (8405)	Instructional 2 Biology 7-12 (8405)
9625157	Keck, Marianne Christine	Instructional	2	Chemistry 7-12 (8420)	Instructional 2 Chemistry 7-12 (8420)
9625157	Keck, Marianne Christine	Instructional	2	Physics 7-12 (8470)	Instructional 2 Physics 7-12 (8470)
9127352	Keefe, Allison A	Instructional	1	English 7-12 (3230)	Instructional 1 English 7-12 (3230)
7041968	Kelso, Sharon A	Instructional	2	English 7-12 (3230)	Instructional 2 English 7-12 (3230)
8258565	Kennedy, Sabrina C	Instructional	2	Elementary K-6 (2810)	Instructional 2 Elementary K-6 (2810)
8258565	Kennedy, Sabrina C	Instructional	2	Special Education PK-12 (9225)	Instructional 2 Special Education PK-12 (9225)
8947597	Kenzakowski, Rebecca A	Instructional	2	Biology 7-12 (8405)	Instructional 2 Biology 7-12 (8405)
8947597	Kenzakowski, Rebecca A	Instructional	2	Special Education PK-12 (9225)	Instructional 2 Special Education PK-12 (9225)
9536245	Kerner, Danielle L	Administrative	1	Principal PK-12 (1115)	Administrative 1 Principal PK-12 (1115)
9536245	Kerner, Danielle L	Private School - Teacher		French K-12 (14410)	Private School - Teacher French K-12 (14410)
9536245	Kerner, Danielle L	Supervisory		Supvr Curriculum & Inst PK-12 (2915)	Supervisory Supvr Curriculum & Inst PK-12 (2915)
9536245	Kerner, Danielle L	Instructional	2	English 7-12 (3230)	Instructional 2 English 7-12 (3230)

State ID	Employee Name	Certificate Type	Level Code	Certificate Description	
9536245	Kerner, Danielle L	Instructional	2	French PK-12 (4410)	Instructional 2 French PK-12 (4410)
6463102	Kerns, Lauren Diehl	Educational Specialist	1	Secondary School Counselor 7-12 (1837)	Educational Specialist 1 Secondary School Counselor 7-12 (1837)
6463102	Kerns, Lauren Diehl	Instructional	2	Mid-Level Mathematics 6-9 (2860)	Instructional 2 Mid-Level Mathematics 6-9 (2860)
6463102	Kerns, Lauren Diehl	Instructional	2	Special Education PK-12 (9225)	Instructional 2 Special Education PK-12 (9225)
1349708	Kessler, Julee Megan	Instructional	2	Ment and/or Phys Handicapped K-12 (9235)	Instructional 2 Ment and/or Phys Handicapped K-12 (9235)
7926129	Kiebler, Megan A	Instructional	2	Elementary K-6 (2810)	Instructional 2 Elementary K-6 (2810)
7926129	Kiebler, Megan A	Instructional	2	Early Childhood N-3 (2840)	Instructional 2 Early Childhood N-3 (2840)
8713091	Kieffer, Brittany E	Instructional	2	Elementary K-6 (2810)	Instructional 2 Elementary K-6 (2810)
8713091	Kieffer, Brittany E	Instructional	2	Special Education PK-12 (9225)	Instructional 2 Special Education PK-12 (9225)
6532305	Kiger, Darian N	Instructional	2	English 7-12 (3230)	Instructional 2 English 7-12 (3230)
2147268	Killam, Caroline Maria	Instructional	1	English 7-12 (3230)	Instructional 1 English 7-12 (3230)
1837828	Kirby, Mary Jean	Instructional	1	Special Education PK-12 (9225)	Instructional 1 Special Education PK-12 (9225)
6725723	Kirchner, Carly Ann	Instructional	2	Elementary K-6 (2810)	Instructional 2 Elementary K-6 (2810)
6725723	Kirchner, Carly Ann	Instructional	2	Special Education PK-12 (9225)	Instructional 2 Special Education PK-12 (9225)
5436107	Klara, Michelle A	Instructional	2	Mid-Level Mathematics 6-9 (2860)	Instructional 2 Mid-Level Mathematics 6-9 (2860)
5436107	Klara, Michelle A	Instructional	2	Mid-Level Science 6-9 (2880)	Instructional 2 Mid-Level Science 6-9 (2880)
5436107	Klara, Michelle A	Instructional	2	Environmental Educ PK-12 (4820)	Instructional 2 Environmental Educ PK-12 (4820)
5436107	Klara, Michelle A	Instructional	2	Biology 7-12 (8405)	Instructional 2 Biology 7-12 (8405)
5436107	Klara, Michelle A	Instructional	2	General Science 7-12 (8450)	Instructional 2 General Science 7-12 (8450)
5436107	Klara, Michelle A	Instructional	2	Physics 7-12 (8470)	Instructional 2 Physics 7-12 (8470)
9038906	Klaus, Jane	Educational Specialist	1	Inst Technology Specialist PK-12 (1825)	Educational Specialist 1 Inst Technology Specialist PK-12 (1825)
9038906	Klaus, Jane	Instructional	1	English 7-12 (3230)	Instructional 1 English 7-12 (3230)
9038906	Klaus, Jane	Instructional	1	Social Studies 7-12 (8875)	Instructional 1 Social Studies 7-12 (8875)
9014616	Klein, Suzanne Elizabeth	Educational Specialist	2	Elementary School Counselor K-6 (1836)	Educational Specialist 2 Elementary School Counselor K-6 (1836)
9014616	Klein, Suzanne Elizabeth	Educational Specialist	2	Secondary School Counselor 7-12 (1837)	Educational Specialist 2 Secondary School Counselor 7-12 (1837)
9638537	Koch, Allison Rose	Instructional	2	Mid-Level Mathematics 6-9 (2860)	Instructional 2 Mid-Level Mathematics 6-9 (2860)
9638537	Koch, Allison Rose	Instructional	2	Family-Consumer Sci PK-12 (5600)	Instructional 2 Family-Consumer Sci PK-12 (5600)
4757876	Kowalok, Krista Marie	Instructional	2	Elementary K-6 (2810)	Instructional 2 Elementary K-6 (2810)
2986176	Kozak, Tamara Ann	Letter of Equivalency		Master's Equivalency - (1185)	Letter of Equivalency Master's Equivalency - (1185)
2986176	Kozak, Tamara Ann	Instructional	2	Elementary K-6 (2810)	Instructional 2 Elementary K-6 (2810)
2986176	Kozak, Tamara Ann	Instructional	2	Ment and/or Phys Handicapped K-12 (9235)	Instructional 2 Ment and/or Phys Handicapped K-12 (9235)
2169428	Kozar, Bridget M	Administrative		Principal PK-12 (1115)	Administrative Principal PK-12 (1115)
2169428	Kozar, Bridget M	Instructional	2	Elementary K-6 (2810)	Instructional 2 Elementary K-6 (2810)
2451951	Kramer, Marc A	Instructional	2	Health & Physical Educ PK-12 (4805)	Instructional 2 Health & Physical Educ PK-12 (4805)
2451951	Kramer, Marc A	Instructional	2	Safety Ed/Driver Ed 7-12 (5215)	Instructional 2 Safety Ed/Driver Ed 7-12 (5215)
3965932	Kreseski, Kimberly Ann	Instructional	2	Elementary K-6 (2810)	Instructional 2 Elementary K-6 (2810)
3965932	Kreseski, Kimberly Ann	Instructional	2	Reading Specialist PK-12 (7650)	Instructional 2 Reading Specialist PK-12 (7650)
1536781	Kreutzer, Candace	Administrative	1	Principal PK-12 (1115)	Administrative 1 Principal PK-12 (1115)
1536781	Kreutzer, Candace	Instructional	2	Grades PK-4 (2825)	Instructional 2 Grades PK-4 (2825)
	Krochak, Carla C	Instructional	1	Reading Specialist PK-12 (7650)	Instructional 1 Reading Specialist PK-12 (7650)
8784304	Krol, Nicole S	Instructional	2	Elementary K-6 (2810)	Instructional 2 Elementary K-6 (2810)
8784304	Krol, Nicole S	Instructional	2	Special Education PK-12 (9225)	Instructional 2 Special Education PK-12 (9225)
1826952	Kroner, Lewis F	Instructional	2	Mid-Level Mathematics 6-9 (2860)	Instructional 2 Mid-Level Mathematics 6-9 (2860)
1826952	Kroner, Lewis F	Instructional	2	Mid-Level Science 6-9 (2880)	Instructional 2 Mid-Level Science 6-9 (2880)
1826952	Kroner, Lewis F	Instructional	2	Music PK-12 (7205)	Instructional 2 Music PK-12 (7205)
7846349	Kubica, Regina Anne	Instructional	2	Mid-Level English 6-9 (2850)	Instructional 2 Mid-Level English 6-9 (2850)

State ID	Employee Name	Certificate Type	Level Code	Certificate Description	
7846349	Kubica, Regina Anne	Instructional	2	Ment and/or Phys Handicapped K-12 (9235)	Instructional 2 Ment and/or Phys Handicapped K-12 (9235)
4972317	Kulp, Justine M	Instructional	2	Elementary K-6 (2810)	Instructional 2 Elementary K-6 (2810)
4972317	Kulp, Justine M	Instructional	2	Mid-Level English 6-9 (2850)	Instructional 2 Mid-Level English 6-9 (2850)
4972317	Kulp, Justine M	Instructional	2	Mid-Level Mathematics 6-9 (2860)	Instructional 2 Mid-Level Mathematics 6-9 (2860)
4972317	Kulp, Justine M	Instructional	2	Mid-Level Citiz. Ed 6-9 (2870)	Instructional 2 Mid-Level Citiz. Ed 6-9 (2870)
4972317	Kulp, Justine M	Program Specialist		English as a Second Language (ESL) PK-12 (4499)	Program Specialist English as a Second Language (ESL) PK-12 (4499)
9868425	Kunc, Joseph	Instructional	1	Mathematics 7-12 (6800)	Instructional 1 Mathematics 7-12 (6800)
4294964	Kunitsky, Diane Marie	Instructional	2	Chemistry 7-12 (8420)	Instructional 2 Chemistry 7-12 (8420)
8471928	Kunkel, William D	Educational Specialist	1	Elem. & Secondary School Counselor PK-12 (1839)	Educational Specialist 1 Elem. & Secondary School Counselor PK-12
8471928	Kunkel, William D	Instructional	1	Social Studies 7-12 (8875)	Instructional 1 Social Studies 7-12 (8875)
9246035	Kwiecinski, Dana Susan	Instructional	1	Elementary K-6 (2810)	Instructional 1 Elementary K-6 (2810)
9246035	Kwiecinski, Dana Susan	Instructional	1	Special Education PK-12 (9225)	Instructional 1 Special Education PK-12 (9225)
5869452	Langer, Shannon E	Instructional	2	Elementary K-6 (2810)	Instructional 2 Elementary K-6 (2810)
5869452	Langer, Shannon E	Instructional	2	Special Education PK-8 (9226)	Instructional 2 Special Education PK-8 (9226)
3902328	Lanzilotta, Kristen Fay	Instructional	2	Elementary K-6 (2810)	Instructional 2 Elementary K-6 (2810)
9379892	Lapsker, Kristina	Instructional	2	Grades PK-4 (2825)	Instructional 2 Grades PK-4 (2825)
9379892	Lapsker, Kristina	Instructional	2	Special Education PK-8 (9226)	Instructional 2 Special Education PK-8 (9226)
7934971	Large, Allison Lee	Instructional	2	Social Studies 7-12 (8875)	Instructional 2 Social Studies 7-12 (8875)
7934971	Large, Allison Lee	Instructional	2	Special Education 7-12 (9227)	Instructional 2 Special Education 7-12 (9227)
9175304	Largent, Beth A	Instructional	2	Elementary K-6 (2810)	Instructional 2 Elementary K-6 (2810)
9175304	Largent, Beth A	Instructional	2	Reading Specialist PK-12 (7650)	Instructional 2 Reading Specialist PK-12 (7650)
9026406	Laser, Mark T	Instructional	2	Bus-Computer-Info Tech PK-12 (1603)	Instructional 2 Bus-Computer-Info Tech PK-12 (1603)
9026406	Laser, Mark T	Instructional	2	Elementary K-6 (2810)	Instructional 2 Elementary K-6 (2810)
9026406	Laser, Mark T	Instructional	2	Mid-Level Mathematics 6-9 (2860)	Instructional 2 Mid-Level Mathematics 6-9 (2860)
5936782	Laubach, Elena	Educational Specialist	2	Secondary School Counselor 7-12 (1837)	Educational Specialist 2 Secondary School Counselor 7-12 (1837)
2707503	Laudenslager, Leslie J	Instructional	2	Elementary K-6 (2810)	Instructional 2 Elementary K-6 (2810)
2707503	Laudenslager, Leslie J	Instructional	2	English 7-12 (3230)	Instructional 2 English 7-12 (3230)
5765745	Lavacca, Deborah Ann	Instructional	2	Elementary K-6 (2810)	Instructional 2 Elementary K-6 (2810)
4392169	Lavelle, Patrick Michael	Instructional	2	Special Education PK-12 (9225)	Instructional 2 Special Education PK-12 (9225)
9481531	Learn, Ryan P	Educational Specialist	2	Secondary School Counselor 7-12 (1837)	Educational Specialist 2 Secondary School Counselor 7-12 (1837)
9481531	Learn, Ryan P	Educational Specialist	2	Elem. & Secondary School Counselor PK-12 (1839)	Educational Specialist 2 Elem. & Secondary School Counselor PK-12
9635647	Lee, Erica Marie	Educational Specialist	2	Secondary School Counselor 7-12 (1837)	Educational Specialist 2 Secondary School Counselor 7-12 (1837)
3478745	LeGendre, Annette Marie	Instructional	2	Physics & Mathematics 7-12 (8475)	Instructional 2 Physics & Mathematics 7-12 (8475)
4956174	Leinweber, Brielle Carol	Instructional	1	Bus-Computer-Info Tech PK-12 (1603)	Instructional 1 Bus-Computer-Info Tech PK-12 (1603)
4956174	Leinweber, Brielle Carol	Instructional	1	Family-Consumer Sci PK-12 (5600)	Instructional 1 Family-Consumer Sci PK-12 (5600)
9089175	Lelko, Susan R	Instructional	2	Bus-Computer-Info Tech PK-12 (1603)	Instructional 2 Bus-Computer-Info Tech PK-12 (1603)
9089175	Lelko, Susan R	Instructional	2	Marketing (Distributive) Ed PK-12 (1666)	Instructional 2 Marketing (Distributive) Ed PK-12 (1666)
9089175	Lelko, Susan R	Instructional	2	Mathematics 7-12 (6800)	Instructional 2 Mathematics 7-12 (6800)
9089175	Lelko, Susan R	Instructional	2	Special Education PK-12 (9225)	Instructional 2 Special Education PK-12 (9225)
8480783	Leon, Casidy Alexa	Instructional	1	Grades PK-4 (2825)	Instructional 1 Grades PK-4 (2825)
8480783	Leon, Casidy Alexa	Instructional	1	Grades 5-6 (2826)	Instructional 1 Grades 5-6 (2826)
8480783	Leon, Casidy Alexa	Instructional	1	Grades 4-8 (All subjects 4-6 Math 7-8) (3100)	Instructional 1 Grades 4-8 (All subjects 4-6 Math 7-8) (3100)
3853409	Leonard, Katie	Instructional	1	English 7-12 (3230)	Instructional 1 English 7-12 (3230)
3853409	Leonard, Katie	Instructional	1	Mathematics 7-12 (6800)	Instructional 1 Mathematics 7-12 (6800)
6850415	Lepsch, Anna E	Endorsement	1	Instructional Coach PK-12 (1182)	Endorsement 1 Instructional Coach PK-12 (1182)
6850415	Lepsch, Anna E	Instructional	2	Elementary K-6 (2810)	Instructional 2 Elementary K-6 (2810)

State ID	Employee Name	Certificate Type	Level Code	Certificate Description	
6850415	Lepsch, Anna E	Instructional	2	Mid-Level English 6-9 (2850)	Instructional 2 Mid-Level English 6-9 (2850)
6850415	Lepsch, Anna E	Instructional	2	Mid-Level Citiz. Ed 6-9 (2870)	Instructional 2 Mid-Level Citiz. Ed 6-9 (2870)
6850415	Lepsch, Anna E	Instructional	2	Mid-Level Science 6-9 (2880)	Instructional 2 Mid-Level Science 6-9 (2880)
6850415	Lepsch, Anna E	Instructional	2	Social Studies 7-12 (8875)	Instructional 2 Social Studies 7-12 (8875)
6850415	Lepsch, Anna E	Instructional	2	Special Education PK-12 (9225)	Instructional 2 Special Education PK-12 (9225)
1960576	Lesczynski, Trisa Ann	Instructional	2	Elementary K-6 (2810)	Instructional 2 Elementary K-6 (2810)
1960576	Lesczynski, Trisa Ann	Instructional	2	Family-Consumer Sci PK-12 (5600)	Instructional 2 Family-Consumer Sci PK-12 (5600)
3183984	Lewis, Jennifer Rebecca	Instructional	2	Elementary K-6 (2810)	Instructional 2 Elementary K-6 (2810)
3183984	Lewis, Jennifer Rebecca	Instructional	2	Reading Specialist PK-12 (7650)	Instructional 2 Reading Specialist PK-12 (7650)
9045025	Linderman, Jessica L	Instructional	1	Elementary K-6 (2810)	Instructional 1 Elementary K-6 (2810)
9045025	Linderman, Jessica L	Instructional	1	Special Education PK-12 (9225)	Instructional 1 Special Education PK-12 (9225)
7462653	Lipiec, Susan E	Instructional	1	Elementary K-6 (2810)	Instructional 1 Elementary K-6 (2810)
7462653	Lipiec, Susan E	Instructional	1	Special Education PK-12 (9225)	Instructional 1 Special Education PK-12 (9225)
2385432	Loccisano, Serena Jo	Administrative	1	Principal PK-12 (1115)	Administrative 1 Principal PK-12 (1115)
2385432	Loccisano, Serena Jo	Instructional	2	Elementary K-6 (2810)	Instructional 2 Elementary K-6 (2810)
2385432	Loccisano, Serena Jo	Instructional	2	Special Education PK-12 (9225)	Instructional 2 Special Education PK-12 (9225)
8343935	Logan, Laura Jean	Instructional	2	Elementary K-6 (2810)	Instructional 2 Elementary K-6 (2810)
8343935	Logan, Laura Jean	Instructional	2	English 7-12 (3230)	Instructional 2 English 7-12 (3230)
8343935	Logan, Laura Jean	Instructional	2	Social Studies 7-12 (8875)	Instructional 2 Social Studies 7-12 (8875)
9782751	Lomax, Megan	Instructional	1	Grades PK-4 (2825)	Instructional 1 Grades PK-4 (2825)
5172808	Lombardo, Jaime L	Instructional	1	English 7-12 (3230)	Instructional 1 English 7-12 (3230)
6141696	Long, Crystal Renee	Instructional	2	Mathematics 7-12 (6800)	Instructional 2 Mathematics 7-12 (6800)
8125042	Long, Naafeisha Tameka	Instructional	1	Grades PK-4 (2825)	Instructional 1 Grades PK-4 (2825)
8125042	Long, Naafeisha Tameka	Instructional	1	Special Education PK-8 (9226)	Instructional 1 Special Education PK-8 (9226)
8762691	Lorcheim, Kristine Frances	Instructional	1	Grades PK-4 (2825)	Instructional 1 Grades PK-4 (2825)
8762691	Lorcheim, Kristine Frances	Instructional	1	Special Education PK-8 (9226)	Instructional 1 Special Education PK-8 (9226)
1097861	Love, Melissa Anne	Instructional	2	Special Education PK-12 (9225)	Instructional 2 Special Education PK-12 (9225)
4237836	Love, Roberta M	Instructional	2	Elementary K-6 (2810)	Instructional 2 Elementary K-6 (2810)
4237836	Love, Roberta M	Instructional	2	Mid-Level English 6-9 (2850)	Instructional 2 Mid-Level English 6-9 (2850)
5349829	Lubich, Luke A	Instructional	2	Health & Physical Educ PK-12 (4805)	Instructional 2 Health & Physical Educ PK-12 (4805)
2705827	Lucia, Jennifer A	Instructional	1	English 7-12 (3230)	Instructional 1 English 7-12 (3230)
2705827	Lucia, Jennifer A	Supervisory		Supvr Special Education PK-12 (9215)	Supervisory Supvr Special Education PK-12 (9215)
2705827	Lucia, Jennifer A	Instructional	1	Special Education PK-12 (9225)	Instructional 1 Special Education PK-12 (9225)
7439432	Luciano, Elizabeth Kathryn	Instructional	1	Elementary K-6 (2810)	Instructional 1 Elementary K-6 (2810)
7439432	Luciano, Elizabeth Kathryn	Instructional	1	English 7-12 (3230)	Instructional 1 English 7-12 (3230)
5606915	Lucier, Heidi A	Instructional	2	Mid-Level Science 6-9 (2880)	Instructional 2 Mid-Level Science 6-9 (2880)
5606915	Lucier, Heidi A	Instructional	2	Biology 7-12 (8405)	Instructional 2 Biology 7-12 (8405)
2781398	Lutz, Amy Lynn	Instructional	2	Elementary K-6 (2810)	Instructional 2 Elementary K-6 (2810)
6193169	Lyman, Stephanie M	Instructional	2	Family-Consumer Sci PK-12 (5600)	Instructional 2 Family-Consumer Sci PK-12 (5600)
6193169	Lyman, Stephanie M	Instructional	2	Social Studies 7-12 (8875)	Instructional 2 Social Studies 7-12 (8875)
9069282	Lynn, Meghan C	Instructional	2	Bus-Computer-Info Tech PK-12 (1603)	Instructional 2 Bus-Computer-Info Tech PK-12 (1603)
2596726	Lynn, Sharon	Instructional	2	Bus-Computer-Info Tech PK-12 (1603)	Instructional 2 Bus-Computer-Info Tech PK-12 (1603)
2596726	Lynn, Sharon	Instructional	2	Safety Ed/Driver Ed 7-12 (5215)	Instructional 2 Safety Ed/Driver Ed 7-12 (5215)
2596726	Lynn, Sharon	Instructional	2	Mathematics 7-12 (6800)	Instructional 2 Mathematics 7-12 (6800)
2596726	Lynn, Sharon	Instructional	2	Special Education PK-12 (9225)	Instructional 2 Special Education PK-12 (9225)
9457194	Mack, Cathryn L	Instructional	2	Ment and/or Phys Handicapped K-12 (9235)	Instructional 2 Ment and/or Phys Handicapped K-12 (9235)



State ID	Employee Name	Certificate Type	Level Code	Certificate Description	
7601878	MacLacklin, Tovah I	Instructional	1	Elementary K-6 (2810)	Instructional 1 Elementary K-6 (2810)
7601878	MacLacklin, Tovah I	Instructional	1	Early Childhood N-3 (2840)	Instructional 1 Early Childhood N-3 (2840)
7601878	MacLacklin, Tovah I	Instructional	1	Mid-Level English 6-9 (2850)	Instructional 1 Mid-Level English 6-9 (2850)
5832314	Macuga, Erica Lynn	Instructional	2	English 7-12 (3230)	Instructional 2 English 7-12 (3230)
6185328	Mahon, Jill	Instructional	2	Elementary K-6 (2810)	Instructional 2 Elementary K-6 (2810)
8152565	Maines, Beth Ann	Instructional	2	Elementary K-6 (2810)	Instructional 2 Elementary K-6 (2810)
7621747	Maio, Pamela	Instructional	2	English 7-12 (3230)	Instructional 2 English 7-12 (3230)
1529129	Majzlik, Angela	Instructional	1	Elementary K-6 (2810)	Instructional 1 Elementary K-6 (2810)
1907396	Mallon, Regina Marie	Instructional	2	Elementary K-6 (2810)	Instructional 2 Elementary K-6 (2810)
1907396	Mallon, Regina Marie	Instructional	2	Mid-Level Citiz. Ed 6-9 (2870)	Instructional 2 Mid-Level Citiz. Ed 6-9 (2870)
1907396	Mallon, Regina Marie	Instructional	2	Reading Specialist PK-12 (7650)	Instructional 2 Reading Specialist PK-12 (7650)
1907396	Mallon, Regina Marie	Instructional	2	Special Education PK-12 (9225)	Instructional 2 Special Education PK-12 (9225)
7169438	Malloy, Marianne E	Instructional	2	Elementary K-6 (2810)	Instructional 2 Elementary K-6 (2810)
7169438	Malloy, Marianne E	Instructional	2	Mid-Level Mathematics 6-9 (2860)	Instructional 2 Mid-Level Mathematics 6-9 (2860)
3865127	Mangano, Melissa Marie	Instructional	1	Grades PK-4 (2825)	Instructional 1 Grades PK-4 (2825)
2918687	Manko, Laura C	Educational Specialist	2	Secondary School Counselor 7-12 (1837)	Educational Specialist 2 Secondary School Counselor 7-12 (1837)
2918687	Manko, Laura C	Supervisory		Supvr Pupil Personnel Serv PK-12 (2930)	Supervisory Supvr Pupil Personnel Serv PK-12 (2930)
8037641	Mannarino, Stephanie Lynn	Instructional	1	Elementary K-6 (2810)	Instructional 1 Elementary K-6 (2810)
8037641	Mannarino, Stephanie Lynn	Instructional	1	Special Education PK-8 (9226)	Instructional 1 Special Education PK-8 (9226)
9431073	Marcello, Stefanie Marlene	Instructional	1	Elementary K-6 (2810)	Instructional 1 Elementary K-6 (2810)
9431073	Marcello, Stefanie Marlene	Instructional	1	Special Education PK-12 (9225)	Instructional 1 Special Education PK-12 (9225)
3930943	Marcinkiewicz, Ilyse Beth	Instructional	1	Mathematics 7-12 (6800)	Instructional 1 Mathematics 7-12 (6800)
4149081	Markle, Jennifer Louise	Instructional	1	English 7-12 (3230)	Instructional 1 English 7-12 (3230)
4149081	Markle, Jennifer Louise	Instructional	1	Special Education 7-12 (9227)	Instructional 1 Special Education 7-12 (9227)
5359412	Marquis, Weston J	Instructional	2	Social Studies 7-12 (8875)	Instructional 2 Social Studies 7-12 (8875)
1736945	Marshall, Casey Marie	Instructional	2	Elementary K-6 (2810)	Instructional 2 Elementary K-6 (2810)
3816487	Marsiliano, Judy	Instructional	2	Mathematics 7-12 (6800)	Instructional 2 Mathematics 7-12 (6800)
7372015	Martin, Jennifer B	Instructional	1	Spanish PK-12 (4490)	Instructional 1 Spanish PK-12 (4490)
5236512	Martin, Susan Rae	Endorsement		Online Instruction Program PK-12 (1184)	Endorsement Online Instruction Program PK-12 (1184)
5236512	Martin, Susan Rae	Instructional	1	Social Studies 7-12 (8875)	Instructional 1 Social Studies 7-12 (8875)
5236512	Martin, Susan Rae	Instructional	1	Special Education 7-12 (9227)	Instructional 1 Special Education 7-12 (9227)
3521429	Martinez, Barbara Ann	Instructional	1	Reading Specialist PK-12 (7650)	Instructional 1 Reading Specialist PK-12 (7650)
3521429	Martinez, Barbara Ann	Instructional	1	Social Studies 7-12 (8875)	Instructional 1 Social Studies 7-12 (8875)
3521429	Martinez, Barbara Ann	Instructional	1	Special Education PK-12 (9225)	Instructional 1 Special Education PK-12 (9225)
1960826	Maruski, Laurie M	Instructional	1	Elementary K-6 (2810)	Instructional 1 Elementary K-6 (2810)
1960826	Maruski, Laurie M	Instructional	1	Reading Specialist PK-12 (7650)	Instructional 1 Reading Specialist PK-12 (7650)
9157434	Mastropietro, Melissa	Instructional	1	Elementary K-6 (2810)	Instructional 1 Elementary K-6 (2810)
4108517	Mattis, Sarah Elizabeth	Instructional	1	Grades PK-4 (2825)	Instructional 1 Grades PK-4 (2825)
4108517	Mattis, Sarah Elizabeth	Instructional	1	Special Education PK-8 (9226)	Instructional 1 Special Education PK-8 (9226)
4136507	McAndrew, Kate Louise	Instructional	2	Earth and Space Science 7-12 (8440)	Instructional 2 Earth and Space Science 7-12 (8440)
4136507	McAndrew, Kate Louise	Instructional	2	General Science 7-12 (8450)	Instructional 2 General Science 7-12 (8450)
1872304	McCabe, Megan Elizabeth	Educational Specialist	2	School Nurse PK-12 (1890)	Educational Specialist 2 School Nurse PK-12 (1890)
3850185	McCarthy, James V	Instructional	2	Mid-Level Mathematics 6-9 (2860)	Instructional 2 Mid-Level Mathematics 6-9 (2860)
3850185	McCarthy, James V	Instructional	2	Health & Physical Educ PK-12 (4805)	Instructional 2 Health & Physical Educ PK-12 (4805)
4386179	McCarthy, Valerie Lynn	Instructional	2	Elementary K-6 (2810)	Instructional 2 Elementary K-6 (2810)
7372496	McCauley, Tamara J	Instructional	1	Elementary K-6 (2810)	Instructional 1 Elementary K-6 (2810)

State ID	Employee Name	Certificate Type	Level Code	Certificate Description	
7372496	McCauley, Tamara J	Instructional	1	Early Childhood N-3 (2840)	Instructional 1 Early Childhood N-3 (2840)
5125785	McClain, Melanie Dawn	Instructional	2	Elementary K-6 (2810)	Instructional 2 Elementary K-6 (2810)
5125785	McClain, Melanie Dawn	Instructional	2	Family-Consumer Sci PK-12 (5600)	Instructional 2 Family-Consumer Sci PK-12 (5600)
2362143	McCleary, Sarah Lorraine	Instructional	1	Elementary K-6 (2810)	Instructional 1 Elementary K-6 (2810)
4363026	McCormick, Heather M	Administrative	2	Principal PK-12 (1115)	Administrative 2 Principal PK-12 (1115)
4363026	McCormick, Heather M	Instructional	2	Mid-Level English 6-9 (2850)	Instructional 2 Mid-Level English 6-9 (2850)
4363026	McCormick, Heather M	Supervisory		Supvr Curriculum & Inst PK-12 (2915)	Supervisory Supvr Curriculum & Inst PK-12 (2915)
4363026	McCormick, Heather M	Instructional	2	Ment and/or Phys Handicapped K-12 (9235)	Instructional 2 Ment and/or Phys Handicapped K-12 (9235)
5340726	McCracken, Kevin S	Instructional	2	Music PK-12 (7205)	Instructional 2 Music PK-12 (7205)
7467268	McCracken, Melissa Kathryn	Instructional	2	Early Childhood N-3 (2840)	Instructional 2 Early Childhood N-3 (2840)
7467268	McCracken, Melissa Kathryn	Instructional	2	Hearing Impaired PK-12 (9205)	Instructional 2 Hearing Impaired PK-12 (9205)
7467268	McCracken, Melissa Kathryn	Instructional	2	Ment and/or Phys Handicapped K-12 (9235)	Instructional 2 Ment and/or Phys Handicapped K-12 (9235)
5843602	McCrea, Julie Ann	Instructional	1	Biology 7-12 (8405)	Instructional 1 Biology 7-12 (8405)
5843602	McCrea, Julie Ann	Instructional	1	Earth and Space Science 7-12 (8440)	Instructional 1 Earth and Space Science 7-12 (8440)
1983458	McCready, Melissa Sue	Instructional	1	Grades PK-4 (2825)	Instructional 1 Grades PK-4 (2825)
1983458	McCready, Melissa Sue	Instructional	1	Grades 5-6 (2826)	Instructional 1 Grades 5-6 (2826)
9503858	McCreary, Adrienne	Instructional	2	Elementary K-6 (2810)	Instructional 2 Elementary K-6 (2810)
9503858	McCreary, Adrienne	Instructional	2	Early Childhood N-3 (2840)	Instructional 2 Early Childhood N-3 (2840)
9503858	McCreary, Adrienne	Instructional	2	Reading Specialist PK-12 (7650)	Instructional 2 Reading Specialist PK-12 (7650)
6052425	McCullough, Kelly S	Instructional	1	Earth and Space Science 7-12 (8440)	Instructional 1 Earth and Space Science 7-12 (8440)
6052425	McCullough, Kelly S	Instructional	1	Social Studies 7-12 (8875)	Instructional 1 Social Studies 7-12 (8875)
7295194	McDermott, Rachael A	Instructional	2	Elementary K-6 (2810)	Instructional 2 Elementary K-6 (2810)
7295194	McDermott, Rachael A	Instructional	2	Early Childhood N-3 (2840)	Instructional 2 Early Childhood N-3 (2840)
7295194	McDermott, Rachael A	Instructional	2	Special Education PK-12 (9225)	Instructional 2 Special Education PK-12 (9225)
9471057	McEwen, Elizabeth Mary	Endorsement		Instructional Coach PK-12 (1182)	Endorsement Instructional Coach PK-12 (1182)
9471057	McEwen, Elizabeth Mary	Instructional	2	Elementary K-6 (2810)	Instructional 2 Elementary K-6 (2810)
9471057	McEwen, Elizabeth Mary	Instructional	2	Mid-Level English 6-9 (2850)	Instructional 2 Mid-Level English 6-9 (2850)
9471057	McEwen, Elizabeth Mary	Instructional	2	English 7-12 (3230)	Instructional 2 English 7-12 (3230)
9471057	McEwen, Elizabeth Mary	Instructional	2	Reading Specialist PK-12 (7650)	Instructional 2 Reading Specialist PK-12 (7650)
9471057	McEwen, Elizabeth Mary	Instructional	2	Special Education PK-12 (9225)	Instructional 2 Special Education PK-12 (9225)
8757232	McGeehan, Rebecca A	Instructional	HOUSSE	General Science 7-12 (8450)	Instructional HOUSSE Designation General Science 7-12 (8450)
5473073	McGinty, Jennifer Nicole	Instructional	2	Elementary K-6 (2810)	Instructional 2 Elementary K-6 (2810)
5473073	McGinty, Jennifer Nicole	Instructional	2	Mid-Level Mathematics 6-9 (2860)	Instructional 2 Mid-Level Mathematics 6-9 (2860)
5473073	McGinty, Jennifer Nicole	Instructional	2	Special Education PK-12 (9225)	Instructional 2 Special Education PK-12 (9225)
3621041	McGlothlin, Shelly L	Administrative	1	Principal PK-12 (1115)	Administrative 1 Principal PK-12 (1115)
3621041	McGlothlin, Shelly L	Supervisory		Supvr Curriculum & Inst PK-12 (2915)	Supervisory Supvr Curriculum & Inst PK-12 (2915)
3621041	McGlothlin, Shelly L	Instructional	2	Communications 7-12 (3200)	Instructional 2 Communications 7-12 (3200)
3621041	McGlothlin, Shelly L	Instructional	2	English 7-12 (3230)	Instructional 2 English 7-12 (3230)
7316426	McGlynn, James G	Instructional	2	Mathematics 7-12 (6800)	Instructional 2 Mathematics 7-12 (6800)
6514235	McHugh, Kristin Lee	Instructional	2	Art PK-12 (1405)	Instructional 2 Art PK-12 (1405)
4819124	McIvor, Ashley N	Educational Specialist	2	School Nurse PK-12 (1890)	Educational Specialist 2 School Nurse PK-12 (1890)
7151362	McKeown, Janelle Lee	Instructional	2	English 7-12 (3230)	Instructional 2 English 7-12 (3230)
8037085	McLaughlin, Kimberly Renee	Instructional	2	Elementary K-6 (2810)	Instructional 2 Elementary K-6 (2810)
8037085	McLaughlin, Kimberly Renee	Instructional	2	Reading Specialist PK-12 (7650)	Instructional 2 Reading Specialist PK-12 (7650)
8037085	McLaughlin, Kimberly Renee	Instructional	2	Special Education PK-12 (9225)	Instructional 2 Special Education PK-12 (9225)
3813852	McMullen, Daniel Christopher	Instructional	1	Mathematics 7-12 (6800)	Instructional 1 Mathematics 7-12 (6800)

State ID	Employee Name	Certificate Type	Level Code	Certificate Description	
8536742	McNulty, Corey Thomas	Instructional	2	Social Studies 7-12 (8875)	Instructional 2 Social Studies 7-12 (8875)
2089109	McNulty, Michael S	Instructional	2	Mathematics 7-12 (6800)	Instructional 2 Mathematics 7-12 (6800)
	McQuaide, David John	Instructional	1	Social Studies 7-12 (8875)	Instructional 1 Social Studies 7-12 (8875)
9635814	McQuaide, Theresa J	Instructional	1	Mathematics 7-12 (6800)	Instructional 1 Mathematics 7-12 (6800)
5652501	McQuillan, Michael T	Instructional	2	Social Studies 7-12 (8875)	Instructional 2 Social Studies 7-12 (8875)
9361723	Mecchia, Jaime Diana	Instructional	2	Elementary K-6 (2810)	Instructional 2 Elementary K-6 (2810)
9361723	Mecchia, Jaime Diana	Program Specialist		English as a Second Language (ESL) PK-12 (4499)	Program Specialist English as a Second Language (ESL) PK-12 (4499)
9361723	Mecchia, Jaime Diana	Instructional	2	Ment and/or Phys Handicapped K-12 (9235)	Instructional 2 Ment and/or Phys Handicapped K-12 (9235)
1659046	Menzler, Sarah Elizabeth	Instructional	2	English 7-12 (3230)	Instructional 2 English 7-12 (3230)
1659046	Menzler, Sarah Elizabeth	Instructional	2	Social Studies 7-12 (8875)	Instructional 2 Social Studies 7-12 (8875)
5494746	Mikkelsen, Melissa Marie	Instructional	1	Grades PK-4 (2825)	Instructional 1 Grades PK-4 (2825)
3078293	Miller, Jeffrey Paul	Administrative	2	Principal PK-12 (1115)	Administrative 2 Principal PK-12 (1115)
3078293	Miller, Jeffrey Paul	Instructional	2	Environmental Educ PK-12 (4820)	Instructional 2 Environmental Educ PK-12 (4820)
3078293	Miller, Jeffrey Paul	Instructional	2	Biology 7-12 (8405)	Instructional 2 Biology 7-12 (8405)
3078293	Miller, Jeffrey Paul	Instructional	2	Earth and Space Science 7-12 (8440)	Instructional 2 Earth and Space Science 7-12 (8440)
5782691	Miller, Samantha	Instructional	2	English 7-12 (3230)	Instructional 2 English 7-12 (3230)
5782691	Miller, Samantha	Instructional	2	Social Studies 7-12 (8875)	Instructional 2 Social Studies 7-12 (8875)
	Mindlin, Elisa L	Instructional	1	Art PK-12 (1405)	Instructional 1 Art PK-12 (1405)
9871308	Mirth, Richard Michael	Educational Specialist	2	Secondary School Counselor 7-12 (1837)	Educational Specialist 2 Secondary School Counselor 7-12 (1837)
9871308	Mirth, Richard Michael	Instructional	2	Mathematics 7-12 (6800)	Instructional 2 Mathematics 7-12 (6800)
5493409	Monterroso, Jacqueline Jay	Instructional	2	Elementary K-6 (2810)	Instructional 2 Elementary K-6 (2810)
5493409	Monterroso, Jacqueline Jay	Instructional	2	Mid-Level Mathematics 6-9 (2860)	Instructional 2 Mid-Level Mathematics 6-9 (2860)
5493409	Monterroso, Jacqueline Jay	Instructional	2	Mid-Level Citiz. Ed 6-9 (2870)	Instructional 2 Mid-Level Citiz. Ed 6-9 (2870)
4580689	Montgomery, James W	Administrative	2	Principal PK-12 (1115)	Administrative 2 Principal PK-12 (1115)
4580689	Montgomery, James W	Instructional	2	Social Studies 7-12 (8875)	Instructional 2 Social Studies 7-12 (8875)
6383075	Moore, Kristen Lynn	Instructional	2	Grades PK-4 (2825)	Instructional 2 Grades PK-4 (2825)
6383075	Moore, Kristen Lynn	Instructional	2	Special Education PK-8 (9226)	Instructional 2 Special Education PK-8 (9226)
1270659	Moran, Mary Katherine	Instructional	1	Grades PK-4 (2825)	Instructional 1 Grades PK-4 (2825)
1270659	Moran, Mary Katherine	Instructional	1	Special Education PK-8 (9226)	Instructional 1 Special Education PK-8 (9226)
2959607	Morantz, Christina Marie	Instructional	1	Elementary K-6 (2810)	Instructional 1 Elementary K-6 (2810)
2959607	Morantz, Christina Marie	Instructional	1	Mid-Level Mathematics 6-9 (2860)	Instructional 1 Mid-Level Mathematics 6-9 (2860)
2959607	Morantz, Christina Marie	Instructional	1	Grades 4-8 (All subjects 4-6 ELA & Reading (3100)	Instructional 1 Grades 4-8 (All subjects 4-6 ELA & Reading (3100)
2959607	Morantz, Christina Marie	Instructional	1	Grades 4-8 (All subjects 4-6 Science 7-8) (3100)	Instructional 1 Grades 4-8 (All subjects 4-6 Science 7-8) (3100)
2959607	Morantz, Christina Marie	Instructional	1	Grades 4-8 (All subjects 4-6, S Stud 7-8) (3100SS)	Instructional 1 Grades 4-8 (All subjects 4-6, S Stud 7-8) (3100SS)
8593738	Moreno, Catherine	Instructional	2	Elementary K-6 (2810)	Instructional 2 Elementary K-6 (2810)
8593738	Moreno, Catherine	Instructional	2	Mid-Level English 6-9 (2850)	Instructional 2 Mid-Level English 6-9 (2850)
8593738	Moreno, Catherine	Instructional	2	Mid-Level Citiz. Ed 6-9 (2870)	Instructional 2 Mid-Level Citiz. Ed 6-9 (2870)
4101806	Morgan, Taryn D	Instructional	2	Agriculture PK-12 (1200)	Instructional 2 Agriculture PK-12 (1200)
3870383	Morian, Diane D	Instructional	2	Elementary K-6 (2810)	Instructional 2 Elementary K-6 (2810)
3870383	Morian, Diane D	Instructional	2	English 7-12 (3230)	Instructional 2 English 7-12 (3230)
3870383	Morian, Diane D	Instructional	2	Ment and/or Phys Handicapped K-12 (9235)	Instructional 2 Ment and/or Phys Handicapped K-12 (9235)
6326159	Moritz, Kristel D	Educational Specialist	1	School Nurse PK-12 (1890)	Educational Specialist 1 School Nurse PK-12 (1890)
3842382	Morlando, Barbara Lynn	Instructional	1	Biology 7-12 (8405)	Instructional 1 Biology 7-12 (8405)
6460725	Morris, Allyson Elizabeth	Instructional	1	Reading Specialist PK-12 (7650)	Instructional 1 Reading Specialist PK-12 (7650)
6460725	Morris, Allyson Elizabeth	Instructional	1	Special Education PK-8 (9226)	Instructional 1 Special Education PK-8 (9226)
6460725	Morris, Allyson Elizabeth	Instructional	1	Special Education 7-12 (9227)	Instructional 1 Special Education 7-12 (9227)

State ID	Employee Name	Certificate Type	Level Code	Certificate Description	
7276923	Morris, Elizabeth	Instructional	2	Mathematics 7-12 (6800)	Instructional 2 Mathematics 7-12 (6800)
5826794	Morrison, Lindsay M	Instructional	2	English 7-12 (3230)	Instructional 2 English 7-12 (3230)
7232784	Morrissey, Laura	Instructional	2	Ment and/or Phys Handicapped K-12 (9235)	Instructional 2 Ment and/or Phys Handicapped K-12 (9235)
5967248	Morrow, Angelina Marie	Instructional	1	Grades PK-4 (2825)	Instructional 1 Grades PK-4 (2825)
5967248	Morrow, Angelina Marie	Instructional	1	Spanish PK-12 (4490)	Instructional 1 Spanish PK-12 (4490)
3056185	Moyer, Amanda J	Instructional	2	Elementary K-6 (2810)	Instructional 2 Elementary K-6 (2810)
3056185	Moyer, Amanda J	Instructional	2	English 7-12 (3230)	Instructional 2 English 7-12 (3230)
3056185	Moyer, Amanda J	Instructional	2	Ment and/or Phys Handicapped K-12 (9235)	Instructional 2 Ment and/or Phys Handicapped K-12 (9235)
6786742	Moyer, Jill A	Instructional	1	Elementary K-6 (2810)	Instructional 1 Elementary K-6 (2810)
6786742	Moyer, Jill A	Instructional	1	Ment and/or Phys Handicapped K-12 (9235)	Instructional 1 Ment and/or Phys Handicapped K-12 (9235)
2856539	Mruskovic, Brenna Colleen	Instructional	1	Social Studies 7-12 (8875)	Instructional 1 Social Studies 7-12 (8875)
9427584	Mueller, Antoinette L	Instructional	2	English 7-12 (3230)	Instructional 2 English 7-12 (3230)
9427584	Mueller, Antoinette L	Instructional	2	Reading Specialist PK-12 (7650)	Instructional 2 Reading Specialist PK-12 (7650)
7510523	Mulhollan, Beth Ann	Instructional	2	Elementary K-6 (2810)	Instructional 2 Elementary K-6 (2810)
7390124	Mulvey, Joanne C	Instructional	2	Mathematics 7-12 (6800)	Instructional 2 Mathematics 7-12 (6800)
7390124	Mulvey, Joanne C	Instructional	2	Physics 7-12 (8470)	Instructional 2 Physics 7-12 (8470)
3820649	Myers, Laci Jo-Lynn	Instructional	1	Elementary K-6 (2810)	Instructional 1 Elementary K-6 (2810)
3820649	Myers, Laci Jo-Lynn	Instructional	1	Mid-Level Mathematics 6-9 (2860)	Instructional 1 Mid-Level Mathematics 6-9 (2860)
6538279	Nagy, Frank Barton	Administrative	2	Principal PK-12 (1115)	Administrative 2 Principal PK-12 (1115)
6538279	Nagy, Frank Barton	Instructional	2	Mathematics 7-12 (6800)	Instructional 2 Mathematics 7-12 (6800)
1786193	Natale, Valerie L	Instructional	2	Elementary K-6 (2810)	Instructional 2 Elementary K-6 (2810)
1786193	Natale, Valerie L	Supervisory		Supvr Special Education PK-12 (9215)	Supervisory Supvr Special Education PK-12 (9215)
1786193	Natale, Valerie L	Instructional	2	Special Education PK-12 (9225)	Instructional 2 Special Education PK-12 (9225)
5713496	Nawn, Erin Marie	Endorsement		Sci. Tech Engineer & Math (STEM) Ed PK-12 (1181)	Endorsement Sci. Tech Engineer & Math (STEM) Ed PK-12 (1181)
5713496	Nawn, Erin Marie	Instructional	2	Elementary K-6 (2810)	Instructional 2 Elementary K-6 (2810)
5713496	Nawn, Erin Marie	Instructional	2	Mid-Level Mathematics 6-9 (2860)	Instructional 2 Mid-Level Mathematics 6-9 (2860)
1981528	Nelson, Eileen C	Educational Specialist	2	Elementary School Counselor K-6 (1836)	Educational Specialist 2 Elementary School Counselor K-6 (1836)
2873471	Nicholas, Fallon Nicole	Educational Specialist	2	Elementary School Counselor K-6 (1836)	Educational Specialist 2 Elementary School Counselor K-6 (1836)
2873471	Nicholas, Fallon Nicole	Educational Specialist	2	Secondary School Counselor 7-12 (1837)	Educational Specialist 2 Secondary School Counselor 7-12 (1837)
8186069	Nicholas, Jesse	Instructional	2	English 7-12 (3230)	Instructional 2 English 7-12 (3230)
8186069	Nicholas, Jesse	Instructional	2	Citizenship 7-12 (8825)	Instructional 2 Citizenship 7-12 (8825)
8186069	Nicholas, Jesse	Instructional	2	Social Studies 7-12 (8875)	Instructional 2 Social Studies 7-12 (8875)
6798439	Nichols, Christina Marie	Instructional	2	Elementary K-6 (2810)	Instructional 2 Elementary K-6 (2810)
6798439	Nichols, Christina Marie	Instructional	2	Mid-Level Mathematics 6-9 (2860)	Instructional 2 Mid-Level Mathematics 6-9 (2860)
6798439	Nichols, Christina Marie	Instructional	2	Mid-Level Science 6-9 (2880)	Instructional 2 Mid-Level Science 6-9 (2880)
6798439	Nichols, Christina Marie	Instructional	2	Earth and Space Science 7-12 (8440)	Instructional 2 Earth and Space Science 7-12 (8440)
6471651	Nickerson Little, Christy Elizabeth	Instructional	2	Grades PK-4 (2825)	Instructional 2 Grades PK-4 (2825)
6471651	Nickerson Little, Christy Elizabeth	Instructional	2	Mid-Level Mathematics 6-9 (2860)	Instructional 2 Mid-Level Mathematics 6-9 (2860)
6471651	Nickerson Little, Christy Elizabeth	Instructional	2	Reading Specialist PK-12 (7650)	Instructional 2 Reading Specialist PK-12 (7650)
7465013	Nicol, Ericka Samuels	Instructional	2	Biology 7-12 (8405)	Instructional 2 Biology 7-12 (8405)
7465013	Nicol, Ericka Samuels	Instructional	2	General Science 7-12 (8450)	Instructional 2 General Science 7-12 (8450)
4085813	Noss, Chelsea Lynne	Instructional	1	Grades PK-4 (2825)	Instructional 1 Grades PK-4 (2825)
4983716	Noss, Kelly Anne	Educational Specialist	2	Elementary School Counselor K-6 (1836)	Educational Specialist 2 Elementary School Counselor K-6 (1836)
4983716	Noss, Kelly Anne	Educational Specialist	2	Secondary School Counselor 7-12 (1837)	Educational Specialist 2 Secondary School Counselor 7-12 (1837)
6128738	Nugent, Emily Elizabeth	Instructional	2	Earth and Space Science 7-12 (8440)	Instructional 2 Earth and Space Science 7-12 (8440)
6128738	Nugent, Emily Elizabeth	Instructional	2	General Science 7-12 (8450)	Instructional 2 General Science 7-12 (8450)

State ID	Employee Name	Certificate Type	Level Code	Certificate Description	
5398423	Nugent, Stephen R	Instructional	2	Social Studies 7-12 (8875)	Instructional 2 Social Studies 7-12 (8875)
5397505	O Donnell, Dana	Instructional	2	Elementary K-6 (2810)	Instructional 2 Elementary K-6 (2810)
5397505	O Donnell, Dana	Instructional	2	Special Education PK-12 (9225)	Instructional 2 Special Education PK-12 (9225)
3809193	O Donnell, Katie E	Instructional	1	Elementary K-6 (2810)	Instructional 1 Elementary K-6 (2810)
3809193	O Donnell, Katie E	Instructional	1	Special Education PK-12 (9225)	Instructional 1 Special Education PK-12 (9225)
5474958	O Neill, Carolyn J	Instructional	2	Elementary K-6 (2810)	Instructional 2 Elementary K-6 (2810)
5474958	O Neill, Carolyn J	Instructional	1	Reading Specialist PK-12 (7650)	Instructional 1 Reading Specialist PK-12 (7650)
5474958	O Neill, Carolyn J	Instructional	2	Special Education PK-12 (9225)	Instructional 2 Special Education PK-12 (9225)
6105673	O Reilly, Jaclyn E	Instructional	2	Elementary K-6 (2810)	Instructional 2 Elementary K-6 (2810)
6105673	O Reilly, Jaclyn E	Instructional	2	Reading Specialist PK-12 (7650)	Instructional 2 Reading Specialist PK-12 (7650)
8451679	Oakes, Casey Louise	Instructional	1	Elementary K-6 (2810)	Instructional 1 Elementary K-6 (2810)
6581921	Oberholtzer, Stephanie L	Instructional	2	Elementary K-6 (2810)	Instructional 2 Elementary K-6 (2810)
8725401	Olbryk, Lacey J	Instructional	2	Grades PK-4 (2825)	Instructional 2 Grades PK-4 (2825)
8725401	Olbryk, Lacey J	Instructional	2	Special Education PK-8 (9226)	Instructional 2 Special Education PK-8 (9226)
6410953	Olsavsky, Michelle Lenore	Endorsement	1	Instructional Coach PK-12 (1182)	Endorsement 1 Instructional Coach PK-12 (1182)
6410953	Olsavsky, Michelle Lenore	Instructional	2	Elementary K-6 (2810)	Instructional 2 Elementary K-6 (2810)
6410953	Olsavsky, Michelle Lenore	Instructional	2	Early Childhood N-3 (2840)	Instructional 2 Early Childhood N-3 (2840)
6410953	Olsavsky, Michelle Lenore	Instructional	2	English 7-12 (3230)	Instructional 2 English 7-12 (3230)
6410953	Olsavsky, Michelle Lenore	Instructional	2	Special Education PK-12 (9225)	Instructional 2 Special Education PK-12 (9225)
1312593	Pacheco, Jose Robert	Instructional	2	French PK-12 (4410)	Instructional 2 French PK-12 (4410)
1312593	Pacheco, Jose Robert	Instructional	2	Mathematics 7-12 (6800)	Instructional 2 Mathematics 7-12 (6800)
5325374	Pacolay, Dana R	Instructional	2	Health PK-12 (4810)	Instructional 2 Health PK-12 (4810)
5325374	Pacolay, Dana R	Instructional	2	Reading Specialist PK-12 (7650)	Instructional 2 Reading Specialist PK-12 (7650)
5325374	Pacolay, Dana R	Instructional	2	Biology 7-12 (8405)	Instructional 2 Biology 7-12 (8405)
5325374	Pacolay, Dana R	Instructional	2	Special Education PK-12 (9225)	Instructional 2 Special Education PK-12 (9225)
3109573	Pagliei, Lynn Marie	Instructional	2	Elementary K-6 (2810)	Instructional 2 Elementary K-6 (2810)
3109573	Pagliei, Lynn Marie	Instructional	2	Mid-Level Mathematics 6-9 (2860)	Instructional 2 Mid-Level Mathematics 6-9 (2860)
3109573	Pagliei, Lynn Marie	Instructional	2	Special Education PK-12 (9225)	Instructional 2 Special Education PK-12 (9225)
8647848	Palme, Jill Elizabeth	Educational Specialist	2	Secondary School Counselor 7-12 (1837)	Educational Specialist 2 Secondary School Counselor 7-12 (1837)
8647848	Palme, Jill Elizabeth	Instructional	1	Elementary K-6 (2810)	Instructional 1 Elementary K-6 (2810)
5735207	Panchura, Chelsey	Instructional	1	English 7-12 (3230)	Instructional 1 English 7-12 (3230)
5735207	Panchura, Chelsey	Instructional	1	Special Education 7-12 (9227)	Instructional 1 Special Education 7-12 (9227)
3172707	Paolino, Kimberly A	Instructional	2	Elementary K-6 (2810)	Instructional 2 Elementary K-6 (2810)
3172707	Paolino, Kimberly A	Instructional	2	Mid-Level English 6-9 (2850)	Instructional 2 Mid-Level English 6-9 (2850)
3172707	Paolino, Kimberly A	Instructional	2	Mid-Level Mathematics 6-9 (2860)	Instructional 2 Mid-Level Mathematics 6-9 (2860)
3172707	Paolino, Kimberly A	Instructional	2	Special Education PK-12 (9225)	Instructional 2 Special Education PK-12 (9225)
4021413	Parkes-Mattox, Gemma M	Instructional	2	English 7-12 (3230)	Instructional 2 English 7-12 (3230)
4021413	Parkes-Mattox, Gemma M	Instructional	2	Special Education PK-12 (9225)	Instructional 2 Special Education PK-12 (9225)
3046982	Pascucci, Jeanne Marie	Instructional	1	Grades PK-4 (2825)	Instructional 1 Grades PK-4 (2825)
3046982	Pascucci, Jeanne Marie	Instructional	1	English 7-12 (3230)	Instructional 1 English 7-12 (3230)
8905083	Pastin, Laurie Lynn	Letter of Equivalency		Master's Equivalency - (1185)	Letter of Equivalency Master's Equivalency - (1185)
8905083	Pastin, Laurie Lynn	Instructional	2	Elementary K-6 (2810)	Instructional 2 Elementary K-6 (2810)
8905083	Pastin, Laurie Lynn	Instructional	2	Grades 4-8 (All subjects 4-6 Math 7-8) (3100)	Instructional 2 Grades 4-8 (All subjects 4-6 Math 7-8) (3100)
7906905	Paterson, Judy	Instructional	1	Elementary K-6 (2810)	Instructional 1 Elementary K-6 (2810)
2429204	Patrick, Agatha A	Instructional	2	Elementary K-6 (2810)	Instructional 2 Elementary K-6 (2810)
2429204	Patrick, Agatha A	Instructional	2	English 7-12 (3230)	Instructional 2 English 7-12 (3230)

State ID	Employee Name	Certificate Type	Level Code	Certificate Description	
2429204	Patrick, Agatha A	Program Specialist		English as a Second Language (ESL) PK-12 (4499)	Program Specialist English as a Second Language (ESL) PK-12 (4499)
2429204	Patrick, Agatha A	Instructional	2	Family-Consumer Sci PK-12 (5600)	Instructional 2 Family-Consumer Sci PK-12 (5600)
2429204	Patrick, Agatha A	Instructional	2	Special Education PK-12 (9225)	Instructional 2 Special Education PK-12 (9225)
2784501	Patterson, Whitney Lynne	Educational Specialist	2	Secondary School Counselor 7-12 (1837)	Educational Specialist 2 Secondary School Counselor 7-12 (1837)
6501895	Pease, Kelly Ann	Instructional	1	English 7-12 (3230)	Instructional 1 English 7-12 (3230)
1630868	Pelipesky, Michele Anne	Instructional	1	Elementary K-6 (2810)	Instructional 1 Elementary K-6 (2810)
1391528	Pelissier, Michelle	Instructional	2	Elementary K-6 (2810)	Instructional 2 Elementary K-6 (2810)
1391528	Pelissier, Michelle	Instructional	2	Early Childhood N-3 (2840)	Instructional 2 Early Childhood N-3 (2840)
1391528	Pelissier, Michelle	Instructional	2	Special Education PK-12 (9225)	Instructional 2 Special Education PK-12 (9225)
1810325	Perri, Renee C	Instructional	2	Ment and/or Phys Handicapped K-12 (9235)	Instructional 2 Ment and/or Phys Handicapped K-12 (9235)
8529764	Petruzzelli, Dena Marie	Instructional	2	English 7-12 (3230)	Instructional 2 English 7-12 (3230)
8529764	Petruzzelli, Dena Marie	Instructional	2	Library Science PK-12 (6420)	Instructional 2 Library Science PK-12 (6420)
8529764	Petruzzelli, Dena Marie	Instructional	2	Reading Specialist PK-12 (7650)	Instructional 2 Reading Specialist PK-12 (7650)
1764107	Pfeiffer, Eric James	Instructional	2	Elementary K-6 (2810)	Instructional 2 Elementary K-6 (2810)
1764107	Pfeiffer, Eric James	Instructional	2	Mid-Level Science 6-9 (2880)	Instructional 2 Mid-Level Science 6-9 (2880)
1764107	Pfeiffer, Eric James	Instructional	2	Earth and Space Science 7-12 (8440)	Instructional 2 Earth and Space Science 7-12 (8440)
3812759	Phillips, Jill Marie	Instructional	2	Elementary K-6 (2810)	Instructional 2 Elementary K-6 (2810)
3812759	Phillips, Jill Marie	Instructional	2	Social Studies 7-12 (8875)	Instructional 2 Social Studies 7-12 (8875)
8023861	Pittman, Sarah B	Instructional	2	Elementary K-6 (2810)	Instructional 2 Elementary K-6 (2810)
8023861	Pittman, Sarah B	Instructional	2	Special Education PK-12 (9225)	Instructional 2 Special Education PK-12 (9225)
3013026	Platt, Keith A	Instructional	2	Health & Physical Educ PK-12 (4805)	Instructional 2 Health & Physical Educ PK-12 (4805)
9616535	Pontious, Brianna	Instructional	1	Grades PK-4 (2825)	Instructional 1 Grades PK-4 (2825)
9616535	Pontious, Brianna	Instructional	1	Special Education PK-8 (9226)	Instructional 1 Special Education PK-8 (9226)
5906173	Porreca, Jessica A	Instructional	1	Elementary K-6 (2810)	Instructional 1 Elementary K-6 (2810)
9302346	Postler, Suzanne	Instructional	1	Elementary K-6 (2810)	Instructional 1 Elementary K-6 (2810)
6893542	Pratt, Robert James	Instructional	1	Elementary K-6 (2810)	Instructional 1 Elementary K-6 (2810)
8174539	Pricer, Danielle Elizabeth	Educational Specialist	2	School Psychologist PK-12 (1875)	Educational Specialist 2 School Psychologist PK-12 (1875)
5202703	Priest, Candice M	Educational Specialist	1	Secondary School Counselor 7-12 (1837)	Educational Specialist 1 Secondary School Counselor 7-12 (1837)
4906579	Purdy Hunsberger, Linda	Instructional	2	Bus-Computer-Info Tech PK-12 (1603)	Instructional 2 Bus-Computer-Info Tech PK-12 (1603)
4906579	Purdy Hunsberger, Linda	Instructional	2	Health & Physical Educ PK-12 (4805)	Instructional 2 Health & Physical Educ PK-12 (4805)
4906579	Purdy Hunsberger, Linda	Instructional	2	Safety Ed/Driver Ed 7-12 (5215)	Instructional 2 Safety Ed/Driver Ed 7-12 (5215)
4906579	Purdy Hunsberger, Linda	Instructional	2	Family-Consumer Sci PK-12 (5600)	Instructional 2 Family-Consumer Sci PK-12 (5600)
8901681	Purdy, Marcy L	Instructional	2	Mathematics 7-12 (6800)	Instructional 2 Mathematics 7-12 (6800)
3132359	Puskar, Kathryn P	Instructional	2	Elementary K-6 (2810)	Instructional 2 Elementary K-6 (2810)
5802785	Pust, Ronda Jean	Instructional	2	Elementary K-6 (2810)	Instructional 2 Elementary K-6 (2810)
4187263	Pytko, Jonathan Clayton	Instructional	2	Social Studies 7-12 (8875)	Instructional 2 Social Studies 7-12 (8875)
2384259	Quackenbush, Kelly J	Instructional	2	Elementary K-6 (2810)	Instructional 2 Elementary K-6 (2810)
2384259	Quackenbush, Kelly J	Instructional	2	Early Childhood N-3 (2840)	Instructional 2 Early Childhood N-3 (2840)
2384259	Quackenbush, Kelly J	Instructional	2	Reading Specialist PK-12 (7650)	Instructional 2 Reading Specialist PK-12 (7650)
2083212	Quisito, Tara Ann	Educational Specialist	2	Secondary School Counselor 7-12 (1837)	Educational Specialist 2 Secondary School Counselor 7-12 (1837)
5674767	Radico, Lauren N	Instructional	1	Elementary K-6 (2810)	Instructional 1 Elementary K-6 (2810)
5674767	Radico, Lauren N	Instructional	1	Reading Specialist PK-12 (7650)	Instructional 1 Reading Specialist PK-12 (7650)
5674767	Radico, Lauren N	Instructional	1	Special Education PK-12 (9225)	Instructional 1 Special Education PK-12 (9225)
7628545	Radio, Scott G	Instructional	2	Elementary K-6 (2810)	Instructional 2 Elementary K-6 (2810)
7628545	Radio, Scott G	Instructional	2	Mid-Level Science 6-9 (2880)	Instructional 2 Mid-Level Science 6-9 (2880)
3097454	Rakowski, Pamela Denise	Instructional	2	Elementary K-6 (2810)	Instructional 2 Elementary K-6 (2810)

State ID	Employee Name	Certificate Type	Level Code	Certificate Description	
8190103	Ramsey, Cathryn A	Administrative	1	Principal PK-12 (1115)	Administrative 1 Principal PK-12 (1115)
8190103	Ramsey, Cathryn A	Instructional	2	Elementary K-6 (2810)	Instructional 2 Elementary K-6 (2810)
8190103	Ramsey, Cathryn A	Instructional	2	Early Childhood N-3 (2840)	Instructional 2 Early Childhood N-3 (2840)
8190103	Ramsey, Cathryn A	Instructional	2	Special Education PK-12 (9225)	Instructional 2 Special Education PK-12 (9225)
1207939	Rau, Sarah Elizabeth	Instructional	2	Biology 7-12 (8405)	Instructional 2 Biology 7-12 (8405)
4603802	Raught, Amy J	Instructional	2	Elementary K-6 (2810)	Instructional 2 Elementary K-6 (2810)
4603802	Raught, Amy J	Instructional	2	Technology Education PK-12 (6075)	Instructional 2 Technology Education PK-12 (6075)
4603802	Raught, Amy J	Instructional	2	Special Education PK-8 (9226)	Instructional 2 Special Education PK-8 (9226)
4603802	Raught, Amy J	Instructional	2	Special Education Expansion 7-12 (9229)	Instructional 2 Special Education Expansion 7-12 (9229)
6798712	Read, Allison Berkowitz	Instructional	2	Elementary K-6 (2810)	Instructional 2 Elementary K-6 (2810)
6798712	Read, Allison Berkowitz	Instructional	2	English 7-12 (3230)	Instructional 2 English 7-12 (3230)
6798712	Read, Allison Berkowitz	Instructional	2	Family-Consumer Sci PK-12 (5600)	Instructional 2 Family-Consumer Sci PK-12 (5600)
9891649	Reamer, Brittany Nicole	Instructional	1	Grades PK-4 (2825)	Instructional 1 Grades PK-4 (2825)
9891649	Reamer, Brittany Nicole	Instructional	1	Special Education PK-8 (9226)	Instructional 1 Special Education PK-8 (9226)
5207967	Reese, Jessica Sara	Instructional	2	Elementary K-6 (2810)	Instructional 2 Elementary K-6 (2810)
5207967	Reese, Jessica Sara	Instructional	2	Mid-Level Mathematics 6-9 (2860)	Instructional 2 Mid-Level Mathematics 6-9 (2860)
5207967	Reese, Jessica Sara	Instructional	2	Special Education PK-8 (9226)	Instructional 2 Special Education PK-8 (9226)
5631375	Reiber, Kiersten Leann	Instructional	2	Elementary K-6 (2810)	Instructional 2 Elementary K-6 (2810)
5631375	Reiber, Kiersten Leann	Instructional	2	Early Childhood N-3 (2840)	Instructional 2 Early Childhood N-3 (2840)
5631375	Reiber, Kiersten Leann	Instructional	2	English 7-12 (3230)	Instructional 2 English 7-12 (3230)
6041706	Reimers, Nancy	Instructional	2	Elementary K-6 (2810)	Instructional 2 Elementary K-6 (2810)
6041706	Reimers, Nancy	Instructional	2	English 7-12 (3230)	Instructional 2 English 7-12 (3230)
6041706	Reimers, Nancy	Instructional	2	Reading Specialist PK-12 (7650)	Instructional 2 Reading Specialist PK-12 (7650)
6041706	Reimers, Nancy	Instructional	2	Ment and/or Phys Handicapped K-12 (9235)	Instructional 2 Ment and/or Phys Handicapped K-12 (9235)
7047017	Reis, Derick J	Instructional	1	Elementary K-6 (2810)	Instructional 1 Elementary K-6 (2810)
6247232	Renner, Katherine	Instructional	1	Reading Specialist PK-12 (7650)	Instructional 1 Reading Specialist PK-12 (7650)
4740526	Rex, Shelley R	Instructional	1	Bus-Computer-Info Tech PK-12 (1603)	Instructional 1 Bus-Computer-Info Tech PK-12 (1603)
5303639	Richards-Walter, Marisa Grace	Instructional	1	Elementary K-6 (2810)	Instructional 1 Elementary K-6 (2810)
5303639	Richards-Walter, Marisa Grace	Instructional	1	Mid-Level Mathematics 6-9 (2860)	Instructional 1 Mid-Level Mathematics 6-9 (2860)
6953949	Richardson, Colleen Shannon	Administrative	1	Principal PK-12 (1115)	Administrative 1 Principal PK-12 (1115)
6953949	Richardson, Colleen Shannon	Instructional	2	Elementary K-6 (2810)	Instructional 2 Elementary K-6 (2810)
6953949	Richardson, Colleen Shannon	Instructional	2	Mid-Level English 6-9 (2850)	Instructional 2 Mid-Level English 6-9 (2850)
6232586	Riexinger, Anna Elizabeth	Instructional	1	Grades 4-8 (All subjects 4-6 Science 7-8) (3100)	Instructional 1 Grades 4-8 (All subjects 4-6 Science 7-8) (3100)
6232586	Riexinger, Anna Elizabeth	Instructional	1	Family-Consumer Sci PK-12 (5600)	Instructional 1 Family-Consumer Sci PK-12 (5600)
6232586	Riexinger, Anna Elizabeth	Instructional	1	Biology 7-12 (8405)	Instructional 1 Biology 7-12 (8405)
9076017	Riggle, Carmen Paige	Instructional	1	Grades PK-4 (2825)	Instructional 1 Grades PK-4 (2825)
9076017	Riggle, Carmen Paige	Instructional	1	Special Education PK-8 (9226)	Instructional 1 Special Education PK-8 (9226)
4810264	Riggs, John	Instructional	2	English 7-12 (3230)	Instructional 2 English 7-12 (3230)
4103425	Rinaldi, Andrew J	Instructional	2	Music PK-12 (7205)	Instructional 2 Music PK-12 (7205)
1576568	Rizzo, Felicia L	Instructional	1	Elementary K-6 (2810)	Instructional 1 Elementary K-6 (2810)
7825478	Robbins, Corina Marie	Instructional	1	Health & Physical Educ PK-12 (4805)	Instructional 1 Health & Physical Educ PK-12 (4805)
1716534	Robosky, Jalina A	Instructional	1	Bus-Computer-Info Tech PK-12 (1603)	Instructional 1 Bus-Computer-Info Tech PK-12 (1603)
1716534	Robosky, Jalina A	Instructional	1	Elementary K-6 (2810)	Instructional 1 Elementary K-6 (2810)
3127261	Rockower, Mindy Sharon	Educational Specialist	2	Elementary School Counselor K-6 (1836)	Educational Specialist 2 Elementary School Counselor K-6 (1836)
3127261	Rockower, Mindy Sharon	Educational Specialist	2	Secondary School Counselor 7-12 (1837)	Educational Specialist 2 Secondary School Counselor 7-12 (1837)
3791683	Rodriguez, Gina	Instructional	1	Grades PK-4 (2825)	Instructional 1 Grades PK-4 (2825)

State ID	Employee Name	Certificate Type	Level Code	Certificate Description	
3791683	Rodriguez, Gina	Instructional	1	Special Education PK-8 (9226)	Instructional 1 Special Education PK-8 (9226)
4210894	Rodzwic, Tara Lynn	Instructional	2	Elementary K-6 (2810)	Instructional 2 Elementary K-6 (2810)
4210894	Rodzwic, Tara Lynn	Instructional	2	Special Education PK-12 (9225)	Instructional 2 Special Education PK-12 (9225)
1092723	Ronosky, Sarah Marie	Instructional	2	Elementary K-6 (2810)	Instructional 2 Elementary K-6 (2810)
1092723	Ronosky, Sarah Marie	Instructional	2	Mid-Level Mathematics 6-9 (2860)	Instructional 2 Mid-Level Mathematics 6-9 (2860)
1092723	Ronosky, Sarah Marie	Supervisory		Supvr Special Education PK-12 (9215)	Supervisory Supvr Special Education PK-12 (9215)
1092723	Ronosky, Sarah Marie	Instructional	2	Special Education PK-12 (9225)	Instructional 2 Special Education PK-12 (9225)
4651015	Rosenbaum, Aliyah Marie	Instructional	1	Grades PK-4 (2825)	Instructional 1 Grades PK-4 (2825)
7276961	Rosenberger, Shauna	Instructional	2	Elementary K-6 (2810)	Instructional 2 Elementary K-6 (2810)
1464047	Ruffner, Zoleanne S	Instructional	1	English 7-12 (3230)	Instructional 1 English 7-12 (3230)
1464047	Ruffner, Zoleanne S	Instructional	1	Social Studies 7-12 (8875)	Instructional 1 Social Studies 7-12 (8875)
2153019	Ryan, Elizabeth B	Endorsement		Online Instruction Program PK-12 (1184)	Endorsement Online Instruction Program PK-12 (1184)
2153019	Ryan, Elizabeth B	Instructional	2	Mathematics 7-12 (6800)	Instructional 2 Mathematics 7-12 (6800)
6950107	Ryen, Brianne B	Instructional	1	Biology 7-12 (8405)	Instructional 1 Biology 7-12 (8405)
6946217	Saad, Tammy L	Instructional	2	Elementary K-6 (2810)	Instructional 2 Elementary K-6 (2810)
6946217	Saad, Tammy L	Instructional	2	Early Childhood N-3 (2840)	Instructional 2 Early Childhood N-3 (2840)
1652126	Salimbene, Ashley Marie	Instructional	2	Social Studies 7-12 (8875)	Instructional 2 Social Studies 7-12 (8875)
1652126	Salimbene, Ashley Marie	Instructional	2	Special Education 7-12 (9227)	Instructional 2 Special Education 7-12 (9227)
7521308	Salony, Lisa	Instructional	1	Elementary K-6 (2810)	Instructional 1 Elementary K-6 (2810)
1934283	Samar, Lisa Steppe	Instructional	2	Elementary K-6 (2810)	Instructional 2 Elementary K-6 (2810)
1934283	Samar, Lisa Steppe	Instructional	2	Early Childhood N-3 (2840)	Instructional 2 Early Childhood N-3 (2840)
1934283	Samar, Lisa Steppe	Instructional	2	Family-Consumer Sci PK-12 (5600)	Instructional 2 Family-Consumer Sci PK-12 (5600)
1934283	Samar, Lisa Steppe	Instructional	2	Reading Specialist PK-12 (7650)	Instructional 2 Reading Specialist PK-12 (7650)
4957692	Sams, Rachel	Instructional	2	Elementary K-6 (2810)	Instructional 2 Elementary K-6 (2810)
3623261	Sanders, Stefanie J	Instructional	1	Grades PK-4 (2825)	Instructional 1 Grades PK-4 (2825)
3623261	Sanders, Stefanie J	Instructional	1	Grades 5-6 (2826)	Instructional 1 Grades 5-6 (2826)
8125834	Sarber, Carl William	Instructional	1	Elementary K-6 (2810)	Instructional 1 Elementary K-6 (2810)
8125834	Sarber, Carl William	Instructional	1	Mid-Level English 6-9 (2850)	Instructional 1 Mid-Level English 6-9 (2850)
8125834	Sarber, Carl William	Instructional	1	Mid-Level Mathematics 6-9 (2860)	Instructional 1 Mid-Level Mathematics 6-9 (2860)
7014575	Sarber, Kenneth Ogden	Instructional	2	Elementary K-6 (2810)	Instructional 2 Elementary K-6 (2810)
7014575	Sarber, Kenneth Ogden	Instructional	2	Mid-Level Mathematics 6-9 (2860)	Instructional 2 Mid-Level Mathematics 6-9 (2860)
3562787	Sattler, Emily R	Educational Specialist	1	Inst Technology Specialist PK-12 (1825)	Educational Specialist 1 Inst Technology Specialist PK-12 (1825)
3562787	Sattler, Emily R	Instructional	2	Elementary K-6 (2810)	Instructional 2 Elementary K-6 (2810)
3562787	Sattler, Emily R	Instructional	2	Mid-Level English 6-9 (2850)	Instructional 2 Mid-Level English 6-9 (2850)
3562787	Sattler, Emily R	Instructional	2	Mid-Level Mathematics 6-9 (2860)	Instructional 2 Mid-Level Mathematics 6-9 (2860)
3562787	Sattler, Emily R	Instructional	2	Mid-Level Citiz. Ed 6-9 (2870)	Instructional 2 Mid-Level Citiz. Ed 6-9 (2870)
3562787	Sattler, Emily R	Instructional	2	Mid-Level Science 6-9 (2880)	Instructional 2 Mid-Level Science 6-9 (2880)
3562787	Sattler, Emily R	Instructional	2	Reading Specialist PK-12 (7650)	Instructional 2 Reading Specialist PK-12 (7650)
6402734	Savitz, Lisa K	Instructional	2	Biology 7-12 (8405)	Instructional 2 Biology 7-12 (8405)
6402734	Savitz, Lisa K	Instructional	2	Chemistry 7-12 (8420)	Instructional 2 Chemistry 7-12 (8420)
6402734	Savitz, Lisa K	Instructional	2	Special Education PK-12 (9225)	Instructional 2 Special Education PK-12 (9225)
2918713	Scears, Breanne M	Instructional	2	Elementary K-6 (2810)	Instructional 2 Elementary K-6 (2810)
2918713	Scears, Breanne M	Instructional	2	Mid-Level English 6-9 (2850)	Instructional 2 Mid-Level English 6-9 (2850)
2918713	Scears, Breanne M	Instructional	2	Reading Specialist PK-12 (7650)	Instructional 2 Reading Specialist PK-12 (7650)
2918713	Scears, Breanne M	Instructional	2	Special Education PK-12 (9225)	Instructional 2 Special Education PK-12 (9225)
6297524	Schall, Danielle Marie	Instructional	2	Elementary K-6 (2810)	Instructional 2 Elementary K-6 (2810)



State ID	Employee Name	Certificate Type	Level Code	Certificate Description	
6297524	Schall, Danielle Marie	Supervisory		Supvr Special Education PK-12 (9215)	Supervisory Supvr Special Education PK-12 (9215)
6297524	Schall, Danielle Marie	Instructional	2	Special Education PK-12 (9225)	Instructional 2 Special Education PK-12 (9225)
1291348	Schar, Jill C	Instructional	1	Elementary K-6 (2810)	Instructional 1 Elementary K-6 (2810)
5365472	Scheib, Alyson Jaye	Instructional	1	General Science 7-12 (8450)	Instructional 1 General Science 7-12 (8450)
1738672	Scheirer, Michael J	Endorsement		Instructional Coach PK-12 (1182)	Endorsement Instructional Coach PK-12 (1182)
1738672	Scheirer, Michael J	Instructional	2	English 7-12 (3230)	Instructional 2 English 7-12 (3230)
1738672	Scheirer, Michael J	Instructional	2	Citizenship 7-12 (8825)	Instructional 2 Citizenship 7-12 (8825)
1738672	Scheirer, Michael J	Instructional	2	Social Studies 7-12 (8875)	Instructional 2 Social Studies 7-12 (8875)
4162507	Scherrbaum, Jaclyn Joyce	Instructional	2	Social Studies 7-12 (8875)	Instructional 2 Social Studies 7-12 (8875)
6546756	Schmidt, Ashley Brooke	Instructional	2	Elementary K-6 (2810)	Instructional 2 Elementary K-6 (2810)
6546756	Schmidt, Ashley Brooke	Instructional	2	Special Education PK-12 (9225)	Instructional 2 Special Education PK-12 (9225)
1754502	Schreiner, Jenna M	Endorsement		Gifted PK-12 (1189)	Endorsement Gifted PK-12 (1189)
1754502	Schreiner, Jenna M	Instructional	2	Elementary K-6 (2810)	Instructional 2 Elementary K-6 (2810)
1754502	Schreiner, Jenna M	Instructional	2	Reading Specialist PK-12 (7650)	Instructional 2 Reading Specialist PK-12 (7650)
1754502	Schreiner, Jenna M	Instructional	2	Special Education PK-12 (9225)	Instructional 2 Special Education PK-12 (9225)
9038206	Schwartz, Olivia Marie	Private School - Asst or Teacher		Nursery/Kindergarten N-K (12833)	Private School - Asst or Teacher Nursery/Kindergarten N-K (12833)
9038206	Schwartz, Olivia Marie	Instructional	2	Elementary K-6 (2810)	Instructional 2 Elementary K-6 (2810)
2496286	Schweizer, Cara Marie	Instructional	2	Environmental Educ PK-12 (4820)	Instructional 2 Environmental Educ PK-12 (4820)
2496286	Schweizer, Cara Marie	Instructional	2	Earth and Space Science 7-12 (8440)	Instructional 2 Earth and Space Science 7-12 (8440)
2496286	Schweizer, Cara Marie	Instructional	2	General Science 7-12 (8450)	Instructional 2 General Science 7-12 (8450)
3057497	Scotillo-Sowa, Christina M	Instructional	1	Elementary K-6 (2810)	Instructional 1 Elementary K-6 (2810)
3057497	Scotillo-Sowa, Christina M	Instructional	1	Special Education PK-12 (9225)	Instructional 1 Special Education PK-12 (9225)
1324972	Scott, Heather Lee	Instructional	1	Health & Physical Educ PK-12 (4805)	Instructional 1 Health & Physical Educ PK-12 (4805)
8263036	Scrip, Erin Marie	Private School - Teacher		Mentally Retarded K-12 (19220)	Private School - Teacher Mentally Retarded K-12 (19220)
8263036	Scrip, Erin Marie	Private School - Teacher		Soc and Emotionally Dist K-12 (19260)	Private School - Teacher Soc and Emotionally Dist K-12 (19260)
8263036	Scrip, Erin Marie	Instructional	2	Elementary K-6 (2810)	Instructional 2 Elementary K-6 (2810)
8263036	Scrip, Erin Marie	Instructional	2	Special Education PK-12 (9225)	Instructional 2 Special Education PK-12 (9225)
	Sears, Mara Boto	Instructional	1	Mathematics 7-12 (6800)	Instructional 1 Mathematics 7-12 (6800)
7012802	Seraut Schlager, Lauren Jannine	Instructional	1	Health & Physical Educ PK-12 (4805)	Instructional 1 Health & Physical Educ PK-12 (4805)
7012802	Seraut Schlager, Lauren Jannine	Instructional	1	Health PK-12 (4810)	Instructional 1 Health PK-12 (4810)
1205208	Severino, Jill	Instructional	2	Elementary K-6 (2810)	Instructional 2 Elementary K-6 (2810)
1205208	Severino, Jill	Instructional	2	English 7-12 (3230)	Instructional 2 English 7-12 (3230)
1205208	Severino, Jill	Instructional	2	Special Education PK-12 (9225)	Instructional 2 Special Education PK-12 (9225)
1219598	Shaffer, Bethann	Instructional	2	Elementary K-6 (2810)	Instructional 2 Elementary K-6 (2810)
1219598	Shaffer, Bethann	Program Specialist		English as a Second Language (ESL) PK-12 (4499)	Program Specialist English as a Second Language (ESL) PK-12 (4499)
1219598	Shaffer, Bethann	Instructional	2	Social Studies 7-12 (8875)	Instructional 2 Social Studies 7-12 (8875)
1219598	Shaffer, Bethann	Instructional	2	Ment and/or Phys Handicapped K-12 (9235)	Instructional 2 Ment and/or Phys Handicapped K-12 (9235)
7290536	Shaffer, Jamie D	Instructional	2	Elementary K-6 (2810)	Instructional 2 Elementary K-6 (2810)
1783096	Shaffer, Janelle R	Instructional	2	Elementary K-6 (2810)	Instructional 2 Elementary K-6 (2810)
1783096	Shaffer, Janelle R	Instructional	2	Special Education PK-12 (9225)	Instructional 2 Special Education PK-12 (9225)
1504512	Shaffer, Lauren Elizabeth	Instructional	2	Social Studies 7-12 (8875)	Instructional 2 Social Studies 7-12 (8875)
7572705	Shaltes, Alison Mislavovich	Instructional	2	Elementary K-6 (2810)	Instructional 2 Elementary K-6 (2810)
7572705	Shaltes, Alison Mislavovich	Instructional	2	Mid-Level English 6-9 (2850)	Instructional 2 Mid-Level English 6-9 (2850)
7572705	Shaltes, Alison Mislavovich	Instructional	2	Reading Specialist PK-12 (7650)	Instructional 2 Reading Specialist PK-12 (7650)
5341385	Shannon, Keri Beth	Instructional	2	Elementary K-6 (2810)	Instructional 2 Elementary K-6 (2810)
5341385	Shannon, Keri Beth	Instructional	HOUSSE	Mid-Level English 6-9 (2850)	Instructional HOUSSE Designation Mid-Level English 6-9 (2850)

State ID	Employee Name	Certificate Type	Level Code	Certificate Description	
5341385	Shannon, Keri Beth	Instructional	HOUSSE	Mid-Level Mathematics 6-9 (2860)	Instructional HOUSSE Designation Mid-Level Mathematics 6-9 (2860)
5341385	Shannon, Keri Beth	Instructional	2	English 7-12 (3230)	Instructional 2 English 7-12 (3230)
5341385	Shannon, Keri Beth	Instructional	2	Special Education PK-12 (9225)	Instructional 2 Special Education PK-12 (9225)
1741679	Shea, Amy M	Educational Specialist	2	Secondary School Counselor 7-12 (1837)	Educational Specialist 2 Secondary School Counselor 7-12 (1837)
5167965	Shebeck, Regan Lynne	Administrative	2	Principal PK-12 (1115)	Administrative 2 Principal PK-12 (1115)
5167965	Shebeck, Regan Lynne	Instructional	2	Biology 7-12 (8405)	Instructional 2 Biology 7-12 (8405)
5167965	Shebeck, Regan Lynne	Instructional	2	General Science 7-12 (8450)	Instructional 2 General Science 7-12 (8450)
4157347	Sheffo, Arlene	Instructional	2	Elementary K-6 (2810)	Instructional 2 Elementary K-6 (2810)
4157347	Sheffo, Arlene	Instructional	2	Mid-Level Mathematics 6-9 (2860)	Instructional 2 Mid-Level Mathematics 6-9 (2860)
4157347	Sheffo, Arlene	Instructional	2	Reading Specialist PK-12 (7650)	Instructional 2 Reading Specialist PK-12 (7650)
7020427	Shehan, Amy M	Educational Specialist	1	Elem. & Secondary School Counselor PK-12 (1839)	Educational Specialist 1 Elem. & Secondary School Counselor PK-12
2016952	Shepard, Selina M	Instructional	2	Biology 7-12 (8405)	Instructional 2 Biology 7-12 (8405)
9217323	Shields, Thomas Richard	Instructional	2	Latin PK-12 (4030)	Instructional 2 Latin PK-12 (4030)
9217323	Shields, Thomas Richard	Instructional	2	Social Studies 7-12 (8875)	Instructional 2 Social Studies 7-12 (8875)
7304928	Shiff, Natalie Lowe	Instructional	1	Elementary K-6 (2810)	Instructional 1 Elementary K-6 (2810)
2391473	Shivetts, Stephanie Lynn	Educational Specialist	2	Elementary School Counselor K-6 (1836)	Educational Specialist 2 Elementary School Counselor K-6 (1836)
2391473	Shivetts, Stephanie Lynn	Educational Specialist	2	Secondary School Counselor 7-12 (1837)	Educational Specialist 2 Secondary School Counselor 7-12 (1837)
5458473	Shonberg, Cynthia Lee	Instructional	2	Biology 7-12 (8405)	Instructional 2 Biology 7-12 (8405)
5458473	Shonberg, Cynthia Lee	Instructional	2	Chemistry 7-12 (8420)	Instructional 2 Chemistry 7-12 (8420)
7028645	Shoop, Elizabeth Ann	Instructional	1	Elementary K-6 (2810)	Instructional 1 Elementary K-6 (2810)
7028645	Shoop, Elizabeth Ann	Instructional	1	Grades 4-8 (All subjects 4-6 Science 7-8) (3100)	Instructional 1 Grades 4-8 (All subjects 4-6 Science 7-8) (3100)
7028645	Shoop, Elizabeth Ann	Instructional	1	Grades 4-8 (All subjects 4-6 Science 7-8) (3100)	Instructional 1 Grades 4-8 (All subjects 4-6 Science 7-8) (3100)
7028645	Shoop, Elizabeth Ann	Instructional	1	Special Education PK-12 (9225)	Instructional 1 Special Education PK-12 (9225)
8646283	Short, Jonna Rose	Instructional	1	Grades PK-4 (2825)	Instructional 1 Grades PK-4 (2825)
8646283	Short, Jonna Rose	Program Specialist		English as a Second Language (ESL) PK-12 (4499)	Program Specialist English as a Second Language (ESL) PK-12 (4499)
9252603	Shuttleworth, Stephen A	Instructional	2	Mid-Level Mathematics 6-9 (2860)	Instructional 2 Mid-Level Mathematics 6-9 (2860)
9252603	Shuttleworth, Stephen A	Instructional	2	Social Studies 7-12 (8875)	Instructional 2 Social Studies 7-12 (8875)
9863512	Silberman, Heather S	Instructional	2	English 7-12 (3230)	Instructional 2 English 7-12 (3230)
9863512	Silberman, Heather S	Instructional	2	Ment and/or Phys Handicapped K-12 (9235)	Instructional 2 Ment and/or Phys Handicapped K-12 (9235)
3415419	Simpson, Nichole Louise	Instructional	2	Art PK-12 (1405)	Instructional 2 Art PK-12 (1405)
8349429	Sinan, Megan C	Instructional	1	English 7-12 (3230)	Instructional 1 English 7-12 (3230)
8349429	Sinan, Megan C	Instructional	1	Family-Consumer Sci PK-12 (5600)	Instructional 1 Family-Consumer Sci PK-12 (5600)
8349429	Sinan, Megan C	Instructional	1	Mathematics 7-12 (6800)	Instructional 1 Mathematics 7-12 (6800)
9674013	Skelly, Cortney Marie	Instructional	2	Grades PK-4 (2825)	Instructional 2 Grades PK-4 (2825)
9674013	Skelly, Cortney Marie	Program Specialist		English as a Second Language (ESL) PK-12 (4499)	Program Specialist English as a Second Language (ESL) PK-12 (4499)
9674013	Skelly, Cortney Marie	Instructional	2	Special Education PK-12 (9225)	Instructional 2 Special Education PK-12 (9225)
2692105	Slacktish, Erinn Keelie	Instructional	HOUSSE	English 7-12 (3230)	Instructional HOUSSE Designation English 7-12 (3230)
2692105	Slacktish, Erinn Keelie	Instructional	HOUSSE	Mathematics 7-12 (6800)	Instructional HOUSSE Designation Mathematics 7-12 (6800)
2692105	Slacktish, Erinn Keelie	Instructional	HOUSSE	Social Studies 7-12 (8875)	Instructional HOUSSE Designation Social Studies 7-12 (8875)
2692105	Slacktish, Erinn Keelie	Supervisory		Supvr Special Education PK-12 (9215)	Supervisory Supvr Special Education PK-12 (9215)
2692105	Slacktish, Erinn Keelie	Instructional	2	Special Education PK-12 (9225)	Instructional 2 Special Education PK-12 (9225)
3835272	Smith, Ashley R	Instructional	2	Elementary K-6 (2810)	Instructional 2 Elementary K-6 (2810)
7083191	Smith, Joseph Bart	Instructional	2	Mid-Level Science 6-9 (2880)	Instructional 2 Mid-Level Science 6-9 (2880)
7083191	Smith, Joseph Bart	Instructional	2	Biology 7-12 (8405)	Instructional 2 Biology 7-12 (8405)
7083191	Smith, Joseph Bart	Instructional	2	General Science 7-12 (8450)	Instructional 2 General Science 7-12 (8450)
5430595	Smith, Laurie B	Clearance		FBI Clearance	Clearance FBI Clearance

State ID	Employee Name	Certificate Type	Level Code	Certificate Description	
5430595	Smith, Laurie B	Clearance		PA Child Abuse Clearance	Clearance PA Child Abuse Clearance
2375103	Smith, Patricia Marie	Instructional	2	Mathematics 7-12 (6800)	Instructional 2 Mathematics 7-12 (6800)
2383109	Smith, Tonya L	Endorsement		Instructional Coach PK-12 (1182)	Endorsement Instructional Coach PK-12 (1182)
2383109	Smith, Tonya L	Instructional	2	English 7-12 (3230)	Instructional 2 English 7-12 (3230)
3045108	Smyntek, Michael A	Instructional	2	Social Studies 7-12 (8875)	Instructional 2 Social Studies 7-12 (8875)
6863973	Snyder, Kelly Leigh	Instructional	2	Elementary K-6 (2810)	Instructional 2 Elementary K-6 (2810)
6863973	Snyder, Kelly Leigh	Instructional	2	Early Childhood N-3 (2840)	Instructional 2 Early Childhood N-3 (2840)
6863973	Snyder, Kelly Leigh	Instructional	2	Reading Specialist PK-12 (7650)	Instructional 2 Reading Specialist PK-12 (7650)
9397186	Soda, Lory A	Instructional	2	Health & Physical Educ PK-12 (4805)	Instructional 2 Health & Physical Educ PK-12 (4805)
3971083	Sonlin, Allison Mott	Instructional	2	Communications 7-12 (3200)	Instructional 2 Communications 7-12 (3200)
3971083	Sonlin, Allison Mott	Instructional	2	English 7-12 (3230)	Instructional 2 English 7-12 (3230)
4517079	Spess, Chantel A	Instructional	2	Social Studies 7-12 (8875)	Instructional 2 Social Studies 7-12 (8875)
4320476	Spindler, Amber L	Instructional	2	Elementary K-6 (2810)	Instructional 2 Elementary K-6 (2810)
4320476	Spindler, Amber L	Instructional	2	Reading Specialist PK-12 (7650)	Instructional 2 Reading Specialist PK-12 (7650)
4320476	Spindler, Amber L	Instructional	2	Special Education PK-12 (9225)	Instructional 2 Special Education PK-12 (9225)
2579716	Spratt, Leslie D	Educational Specialist	1	Elem. & Secondary School Counselor PK-12 (1839)	Educational Specialist 1 Elem. & Secondary School Counselor PK-12
2579716	Spratt, Leslie D	Instructional	2	Ment and/or Phys Handicapped K-12 (9235)	Instructional 2 Ment and/or Phys Handicapped K-12 (9235)
9214593	Staab, Michelle L	Instructional	2	Elementary K-6 (2810)	Instructional 2 Elementary K-6 (2810)
7238027	Stabilito, Catherine M	Instructional	2	Library Science PK-12 (6420)	Instructional 2 Library Science PK-12 (6420)
7238027	Stabilito, Catherine M	Instructional	2	Social Studies 7-12 (8875)	Instructional 2 Social Studies 7-12 (8875)
8269473	Stalebrink, Meghan D	Instructional	2	English 7-12 (3230)	Instructional 2 English 7-12 (3230)
2865256	Staley, Amber	Instructional	2	Elementary K-6 (2810)	Instructional 2 Elementary K-6 (2810)
2865256	Staley, Amber	Instructional	2	Special Education PK-12 (9225)	Instructional 2 Special Education PK-12 (9225)
1658035	Staley, Ashly D	Instructional	2	English 7-12 (3230)	Instructional 2 English 7-12 (3230)
1658035	Staley, Ashly D	Instructional	2	Mathematics 7-12 (6800)	Instructional 2 Mathematics 7-12 (6800)
1534506	Stanforth, Melanie	Instructional	1	Speech & Language Impaired PK-12 (9265)	Instructional 1 Speech & Language Impaired PK-12 (9265)
5026504	Stapf, Laura L	Instructional	2	Elementary K-6 (2810)	Instructional 2 Elementary K-6 (2810)
5026504	Stapf, Laura L	Instructional	2	Special Education PK-12 (9225)	Instructional 2 Special Education PK-12 (9225)
3815368	Stecker, Pamela	Endorsement		Gifted PK-12 (1189)	Endorsement Gifted PK-12 (1189)
3815368	Stecker, Pamela	Instructional	2	English 7-12 (3230)	Instructional 2 English 7-12 (3230)
9858356	Steinberg, Natalie Blair	Instructional	1	Elementary K-6 (2810)	Instructional 1 Elementary K-6 (2810)
6309037	Stenson, Lauren	Educational Specialist	2	Elem. & Secondary School Counselor PK-12 (1839)	Educational Specialist 2 Elem. & Secondary School Counselor PK-12 (1839)
2937845	Stephenson, Tiana Noelle	Instructional	1	English 7-12 (3230)	Instructional 1 English 7-12 (3230)
2937845	Stephenson, Tiana Noelle	Instructional	1	Special Education 7-12 (9227)	Instructional 1 Special Education 7-12 (9227)
5650892	Stevens, Beth Ann	Instructional	2	Elementary K-6 (2810)	Instructional 2 Elementary K-6 (2810)
5835909	Stevens, Brett Elizabeth	Instructional	1	Grades PK-4 (2825)	Instructional 1 Grades PK-4 (2825)
5835909	Stevens, Brett Elizabeth	Instructional	1	Grades 5-6 (2826)	Instructional 1 Grades 5-6 (2826)
5835909	Stevens, Brett Elizabeth	Instructional	1	English 7-12 (3230)	Instructional 1 English 7-12 (3230)
5835909	Stevens, Brett Elizabeth	Instructional	1	Social Studies 7-12 (8875)	Instructional 1 Social Studies 7-12 (8875)
5835909	Stevens, Brett Elizabeth	Instructional	1	Special Education PK-8 (9226)	Instructional 1 Special Education PK-8 (9226)
5835909	Stevens, Brett Elizabeth	Instructional	1	Special Education Expansion 7-12 (9229)	Instructional 1 Special Education Expansion 7-12 (9229)
9801486	Stiles, Heather	Instructional	2	Biology 7-12 (8405)	Instructional 2 Biology 7-12 (8405)
3639419	Stone, Leah M	Instructional	2	Family-Consumer Sci PK-12 (5600)	Instructional 2 Family-Consumer Sci PK-12 (5600)
3639419	Stone, Leah M	Instructional	2	Mathematics 7-12 (6800)	Instructional 2 Mathematics 7-12 (6800)
4316015	Strong, Kimberly	Instructional	2	Elementary K-6 (2810)	Instructional 2 Elementary K-6 (2810)

State ID	Employee Name	Certificate Type	Level Code	Certificate Description	
8359342	Stump, Melissa C	Instructional	2	Art PK-12 (1405)	Instructional 2 Art PK-12 (1405)
8359342	Stump, Melissa C	Instructional	2	English 7-12 (3230)	Instructional 2 English 7-12 (3230)
8359342	Stump, Melissa C	Instructional	2	Special Education PK-12 (9225)	Instructional 2 Special Education PK-12 (9225)
7576194	Stump, Shelley A	Instructional	2	Elementary K-6 (2810)	Instructional 2 Elementary K-6 (2810)
7576194	Stump, Shelley A	Instructional	2	Mid-Level English 6-9 (2850)	Instructional 2 Mid-Level English 6-9 (2850)
7576194	Stump, Shelley A	Instructional	2	Mid-Level Mathematics 6-9 (2860)	Instructional 2 Mid-Level Mathematics 6-9 (2860)
7576194	Stump, Shelley A	Instructional	2	Mid-Level Citiz. Ed 6-9 (2870)	Instructional 2 Mid-Level Citiz. Ed 6-9 (2870)
7576194	Stump, Shelley A	Instructional	2	Mid-Level Science 6-9 (2880)	Instructional 2 Mid-Level Science 6-9 (2880)
7576194	Stump, Shelley A	Instructional	2	Health & Physical Educ PK-12 (4805)	Instructional 2 Health & Physical Educ PK-12 (4805)
7576194	Stump, Shelley A	Instructional	2	Special Education PK-12 (9225)	Instructional 2 Special Education PK-12 (9225)
3608741	Sukanick, Peter D	Instructional	2	Health & Physical Educ PK-12 (4805)	Instructional 2 Health & Physical Educ PK-12 (4805)
8068396	Super, Laurie Gail	Endorsement		Instructional Coach PK-12 (1182)	Endorsement Instructional Coach PK-12 (1182)
8068396	Super, Laurie Gail	Instructional	2	Elementary K-6 (2810)	Instructional 2 Elementary K-6 (2810)
8068396	Super, Laurie Gail	Instructional	2	Special Education PK-12 (9225)	Instructional 2 Special Education PK-12 (9225)
6873915	Svonavec, Lauren J	Instructional	2	Grades PK-4 (2825)	Instructional 2 Grades PK-4 (2825)
6873915	Svonavec, Lauren J	Instructional	2	Reading Specialist PK-12 (7650)	Instructional 2 Reading Specialist PK-12 (7650)
6873915	Svonavec, Lauren J	Instructional	2	Special Education PK-8 (9226)	Instructional 2 Special Education PK-8 (9226)
6797603	Sweeney, Allison	Instructional	2	Elementary K-6 (2810)	Instructional 2 Elementary K-6 (2810)
6797603	Sweeney, Allison	Instructional	2	Special Education PK-12 (9225)	Instructional 2 Special Education PK-12 (9225)
2109704	Swick, Brittney Jean	Instructional	2	Elementary K-6 (2810)	Instructional 2 Elementary K-6 (2810)
2109704	Swick, Brittney Jean	Instructional	2	Special Education PK-12 (9225)	Instructional 2 Special Education PK-12 (9225)
1704203	Taggart, Andrea	Instructional	2	Elementary K-6 (2810)	Instructional 2 Elementary K-6 (2810)
1704203	Taggart, Andrea	Instructional	2	Reading Specialist PK-12 (7650)	Instructional 2 Reading Specialist PK-12 (7650)
1305876	Tainter, Erin F	Instructional	2	Mid-Level Science 6-9 (2880)	Instructional 2 Mid-Level Science 6-9 (2880)
1305876	Tainter, Erin F	Instructional	2	Biology 7-12 (8405)	Instructional 2 Biology 7-12 (8405)
1305876	Tainter, Erin F	Instructional	2	Chemistry 7-12 (8420)	Instructional 2 Chemistry 7-12 (8420)
6925283	Tapera, Dana	Instructional	1	Mathematics 7-12 (6800)	Instructional 1 Mathematics 7-12 (6800)
7820563	Taylor, Laura Ellen	Instructional	1	Elementary K-6 (2810)	Instructional 1 Elementary K-6 (2810)
8157431	Thayer, Barbara Jean	Instructional	2	Elementary K-6 (2810)	Instructional 2 Elementary K-6 (2810)
8157431	Thayer, Barbara Jean	Instructional	2	Early Childhood N-3 (2840)	Instructional 2 Early Childhood N-3 (2840)
8157431	Thayer, Barbara Jean	Instructional	2	English 7-12 (3230)	Instructional 2 English 7-12 (3230)
8157431	Thayer, Barbara Jean	Instructional	2	Reading Specialist PK-12 (7650)	Instructional 2 Reading Specialist PK-12 (7650)
1601727	Thomas, Amber Marie	Instructional	1	Grades PK-4 (2825)	Instructional 1 Grades PK-4 (2825)
1601727	Thomas, Amber Marie	Instructional	1	Special Education PK-8 (9226)	Instructional 1 Special Education PK-8 (9226)
9515616	Thomas, Christine Wiles	Instructional	2	Elementary K-6 (2810)	Instructional 2 Elementary K-6 (2810)
9515616	Thomas, Christine Wiles	Instructional	2	Mid-Level English 6-9 (2850)	Instructional 2 Mid-Level English 6-9 (2850)
9515616	Thomas, Christine Wiles	Instructional	2	Mid-Level Mathematics 6-9 (2860)	Instructional 2 Mid-Level Mathematics 6-9 (2860)
9515616	Thomas, Christine Wiles	Instructional	2	Special Education PK-12 (9225)	Instructional 2 Special Education PK-12 (9225)
9747167	Thomas, Jennine Michelle	Instructional	2	Social Studies 7-12 (8875)	Instructional 2 Social Studies 7-12 (8875)
9564086	Thomas, John C	Endorsement		Instructional Coach PK-12 (1182)	Endorsement Instructional Coach PK-12 (1182)
9564086	Thomas, John C	Instructional	2	Citizenship 7-12 (8825)	Instructional 2 Citizenship 7-12 (8825)
8617958	Thomas, Robert John	Instructional	1	Art PK-12 (1405)	Instructional 1 Art PK-12 (1405)
5415083	Thompson, Jennifer M	Private School - Asst or Teacher		Nursery/Kindergarten N-K (12833)	Private School - Asst or Teacher Nursery/Kindergarten N-K (12833)
5415083	Thompson, Jennifer M	Instructional	2	Elementary K-6 (2810)	Instructional 2 Elementary K-6 (2810)
3189451	Tilsner, Michelle	Instructional	2	English 7-12 (3230)	Instructional 2 English 7-12 (3230)
3189451	Tilsner, Michelle	Instructional	2	Reading Specialist PK-12 (7650)	Instructional 2 Reading Specialist PK-12 (7650)

State ID	Employee Name	Certificate Type	Level Code	Certificate Description	
3189451	Tilsner, Michelle	Instructional	2	Social Studies 7-12 (8875)	Instructional 2 Social Studies 7-12 (8875)
6732795	Titus, Lorna Francesca	Instructional	1	Elementary K-6 (2810)	Instructional 1 Elementary K-6 (2810)
6732795	Titus, Lorna Francesca	Instructional	1	Special Education PK-12 (9225)	Instructional 1 Special Education PK-12 (9225)
6375062	Tkach, Amber L	Instructional	2	English 7-12 (3230)	Instructional 2 English 7-12 (3230)
6045927	Tomik, Amanda	Instructional	1	Grades PK-4 (2825)	Instructional 1 Grades PK-4 (2825)
6045927	Tomik, Amanda	Instructional	1	Grades 5-6 (2826)	Instructional 1 Grades 5-6 (2826)
4108214	Trott, Alyssa Marie	Instructional	1	Elementary K-6 (2810)	Instructional 1 Elementary K-6 (2810)
4108214	Trott, Alyssa Marie	Instructional	1	Special Education PK-8 (9226)	Instructional 1 Special Education PK-8 (9226)
4108214	Trott, Alyssa Marie	Instructional	1	Special Education Expansion 7-12 (9229)	Instructional 1 Special Education Expansion 7-12 (9229)
9463507	Tumas, John P	Instructional	2	Bus-Computer-Info Tech PK-12 (1603)	Instructional 2 Bus-Computer-Info Tech PK-12 (1603)
9463507	Tumas, John P	Instructional	2	Library Science PK-12 (6420)	Instructional 2 Library Science PK-12 (6420)
9463507	Tumas, John P	Instructional	2	Social Studies 7-12 (8875)	Instructional 2 Social Studies 7-12 (8875)
3526216	Tybl, Mary Susan	Instructional	2	Mathematics 7-12 (6800)	Instructional 2 Mathematics 7-12 (6800)
6535281	Tymeson, Leah A	Instructional	1	Earth and Space Science 7-12 (8440)	Instructional 1 Earth and Space Science 7-12 (8440)
1953249	Ulewicz, Janet Marie	Instructional	2	Elementary K-6 (2810)	Instructional 2 Elementary K-6 (2810)
1953249	Ulewicz, Janet Marie	Instructional	2	Special Education PK-8 (9226)	Instructional 2 Special Education PK-8 (9226)
5051796	Vasil, Jay J	Administrative	1	Principal PK-12 (1115)	Administrative 1 Principal PK-12 (1115)
5051796	Vasil, Jay J	Administrative		Vocational Admin Dir. 7-12 (2300)	Administrative Vocational Admin Dir. 7-12 (2300)
5051796	Vasil, Jay J	Instructional	2	Mid-Level English 6-9 (2850)	Instructional 2 Mid-Level English 6-9 (2850)
5051796	Vasil, Jay J	Instructional	2	Mid-Level Citiz. Ed 6-9 (2870)	Instructional 2 Mid-Level Citiz. Ed 6-9 (2870)
5051796	Vasil, Jay J	Instructional	2	Health & Physical Educ PK-12 (4805)	Instructional 2 Health & Physical Educ PK-12 (4805)
5051796	Vasil, Jay J	Instructional	2	Safety Ed/Driver Ed 7-12 (5215)	Instructional 2 Safety Ed/Driver Ed 7-12 (5215)
5051796	Vasil, Jay J	Instructional	2	Family-Consumer Sci PK-12 (5600)	Instructional 2 Family-Consumer Sci PK-12 (5600)
2784396	Velto, Rachel Andrea	Instructional	2	English 7-12 (3230)	Instructional 2 English 7-12 (3230)
2784396	Velto, Rachel Andrea	Instructional	2	Spanish PK-12 (4490)	Instructional 2 Spanish PK-12 (4490)
1429502	Verbecken, Michelle Lee	Private School - Asst or Teacher		Nursery/Kindergarten N-K (12833)	Private School - Asst or Teacher Nursery/Kindergarten N-K (12833)
1429502	Verbecken, Michelle Lee	Instructional	2	Elementary K-6 (2810)	Instructional 2 Elementary K-6 (2810)
5735753	Vietmeier, Stacy L	Instructional	2	Elementary K-6 (2810)	Instructional 2 Elementary K-6 (2810)
5735753	Vietmeier, Stacy L	Instructional	HOUSSE	English 7-12 (3230)	Instructional HOUSSE Designation English 7-12 (3230)
5735753	Vietmeier, Stacy L	Instructional	HOUSSE	General Science 7-12 (8450)	Instructional HOUSSE Designation General Science 7-12 (8450)
5735753	Vietmeier, Stacy L	Instructional	HOUSSE	Social Studies 7-12 (8875)	Instructional HOUSSE Designation Social Studies 7-12 (8875)
5735753	Vietmeier, Stacy L	Instructional	2	Special Education PK-12 (9225)	Instructional 2 Special Education PK-12 (9225)
1821694	Volpe, Vallorrie Fitzgerald	Instructional	2	Elementary K-6 (2810)	Instructional 2 Elementary K-6 (2810)
1821694	Volpe, Vallorrie Fitzgerald	Instructional	2	Mid-Level Mathematics 6-9 (2860)	Instructional 2 Mid-Level Mathematics 6-9 (2860)
1821694	Volpe, Vallorrie Fitzgerald	Instructional	2	Mid-Level Science 6-9 (2880)	Instructional 2 Mid-Level Science 6-9 (2880)
2742075	Vuong Schmick, Thy Minh	Instructional	2	Mid-Level Science 6-9 (2880)	Instructional 2 Mid-Level Science 6-9 (2880)
2742075	Vuong Schmick, Thy Minh	Instructional	2	Chemistry 7-12 (8420)	Instructional 2 Chemistry 7-12 (8420)
9241316	Wagner, Alexis Carolina	Instructional	1	Social Studies 7-12 (8875)	Instructional 1 Social Studies 7-12 (8875)
9241316	Wagner, Alexis Carolina	Instructional	1	Special Education 7-12 (9227)	Instructional 1 Special Education 7-12 (9227)
1657956	Walczak, Brittney Ann	Instructional	1	Grades PK-4 (2825)	Instructional 1 Grades PK-4 (2825)
1657956	Walczak, Brittney Ann	Instructional	1	Special Education PK-8 (9226)	Instructional 1 Special Education PK-8 (9226)
2382481	Walker, Tara M	Instructional	1	Special Education PK-12 (9225)	Instructional 1 Special Education PK-12 (9225)
7358162	Walsh, Mary Elise	Letter of Equivalency		Master's Equivalency - (1185)	Letter of Equivalency Master's Equivalency - (1185)
7358162	Walsh, Mary Elise	Instructional	2	Elementary K-6 (2810)	Instructional 2 Elementary K-6 (2810)
7358162	Walsh, Mary Elise	Instructional	2	Mid-Level English 6-9 (2850)	Instructional 2 Mid-Level English 6-9 (2850)
7358162	Walsh, Mary Elise	Instructional	2	Mid-Level Mathematics 6-9 (2860)	Instructional 2 Mid-Level Mathematics 6-9 (2860)

State ID	Employee Name	Certificate Type	Level Code	Certificate Description	
7358162	Walsh, Mary Elise	Program Specialist		English as a Second Language (ESL) PK-12 (4499)	Program Specialist English as a Second Language (ESL) PK-12 (4499)
9097202	Walters, Carrie Irene	Instructional	1	Elementary K-6 (2810)	Instructional 1 Elementary K-6 (2810)
1978748	Walters, Melanie A	Instructional	2	Mid-Level Science 6-9 (2880)	Instructional 2 Mid-Level Science 6-9 (2880)
1978748	Walters, Melanie A	Instructional	2	Reading Specialist PK-12 (7650)	Instructional 2 Reading Specialist PK-12 (7650)
1978748	Walters, Melanie A	Instructional	2	Biology 7-12 (8405)	Instructional 2 Biology 7-12 (8405)
5276125	Waters, Nancy Miriam	Instructional	2	Bus-Computer-Info Tech PK-12 (1603)	Instructional 2 Bus-Computer-Info Tech PK-12 (1603)
5276125	Waters, Nancy Miriam	Instructional	2	Marketing 7-12 (1640)	Instructional 2 Marketing 7-12 (1640)
5276125	Waters, Nancy Miriam	Instructional	2	Office Technologies 7-12 (1658)	Instructional 2 Office Technologies 7-12 (1658)
5276125	Waters, Nancy Miriam	Program Specialist		English as a Second Language (ESL) PK-12 (4499)	Program Specialist English as a Second Language (ESL) PK-12 (4499)
2562529	Watts, Brigitt	Instructional	2	Art PK-12 (1405)	Instructional 2 Art PK-12 (1405)
2562529	Watts, Brigitt	Instructional	2	Bus-Computer-Info Tech PK-12 (1603)	Instructional 2 Bus-Computer-Info Tech PK-12 (1603)
2156432	Webb, Alexandra L	Instructional	2	Elementary K-6 (2810)	Instructional 2 Elementary K-6 (2810)
6989536	Webb, Ryan Michael	Instructional	1	Health & Physical Educ PK-12 (4805)	Instructional 1 Health & Physical Educ PK-12 (4805)
2613297	Weeks, Rachel Nicole	Instructional	1	Grades PK-4 (2825)	Instructional 1 Grades PK-4 (2825)
2613297	Weeks, Rachel Nicole	Instructional	1	Special Education PK-8 (9226)	Instructional 1 Special Education PK-8 (9226)
8219472	Weikert, Sarah E	Instructional	2	Art PK-12 (1405)	Instructional 2 Art PK-12 (1405)
5204709	Weisz, Christopher Joseph	Instructional	2	Social Studies 7-12 (8875)	Instructional 2 Social Studies 7-12 (8875)
3715812	Welsh, Kristy	Instructional	2	Elementary K-6 (2810)	Instructional 2 Elementary K-6 (2810)
3715812	Welsh, Kristy	Instructional	2	Mid-Level Mathematics 6-9 (2860)	Instructional 2 Mid-Level Mathematics 6-9 (2860)
3715812	Welsh, Kristy	Instructional	2	Mid-Level Science 6-9 (2880)	Instructional 2 Mid-Level Science 6-9 (2880)
3715812	Welsh, Kristy	Instructional	2	Special Education PK-12 (9225)	Instructional 2 Special Education PK-12 (9225)
1248284	Wesley, Mindy C	Educational Specialist	1	Elem. & Secondary School Counselor PK-12 (1839)	Educational Specialist 1 Elem. & Secondary School Counselor PK-12 (1839)
1248284	Wesley, Mindy C	Instructional	1	Special Education PK-12 (9225)	Instructional 1 Special Education PK-12 (9225)
9382145	West, Megan Marie	Instructional	1	Grades 4-8 (All subjects 4-6, S Stud 7-8) (3100SS)	Instructional 1 Grades 4-8 (All subjects 4-6, S Stud 7-8) (3100SS)
9895439	Whippo, Janet Demay	Instructional	2	Elementary K-6 (2810)	Instructional 2 Elementary K-6 (2810)
9895439	Whippo, Janet Demay	Instructional	2	Reading Specialist PK-12 (7650)	Instructional 2 Reading Specialist PK-12 (7650)
2354696	White, Andrew	Instructional	1	Elementary K-6 (2810)	Instructional 1 Elementary K-6 (2810)
8239726	Whitebread, Autumn Lee	Administrative	1	Principal PK-12 (1115)	Administrative 1 Principal PK-12 (1115)
8239726	Whitebread, Autumn Lee	Instructional	2	Elementary K-6 (2810)	Instructional 2 Elementary K-6 (2810)
8239726	Whitebread, Autumn Lee	Instructional	2	Mid-Level Science 6-9 (2880)	Instructional 2 Mid-Level Science 6-9 (2880)
8239726	Whitebread, Autumn Lee	Instructional	2	Reading Specialist PK-12 (7650)	Instructional 2 Reading Specialist PK-12 (7650)
5452091	Whited, Barron Gene	Educational Specialist	2	Elementary School Counselor K-6 (1836)	Educational Specialist 2 Elementary School Counselor K-6 (1836)
5452091	Whited, Barron Gene	Educational Specialist	2	Secondary School Counselor 7-12 (1837)	Educational Specialist 2 Secondary School Counselor 7-12 (1837)
9610585	Whitmore, Heather Anne	Instructional	1	Elementary K-6 (2810)	Instructional 1 Elementary K-6 (2810)
9610585	Whitmore, Heather Anne	Instructional	1	Reading Specialist PK-12 (7650)	Instructional 1 Reading Specialist PK-12 (7650)
5830501	Whitmoyer, Jessica Lynn	Educational Specialist	1	Inst Technology Specialist PK-12 (1825)	Educational Specialist 1 Inst Technology Specialist PK-12 (1825)
5830501	Whitmoyer, Jessica Lynn	Instructional	2	Social Studies 7-12 (8875)	Instructional 2 Social Studies 7-12 (8875)
	Whitted, Stephanie R	Instructional	1	English 7-12 (3230)	Instructional 1 English 7-12 (3230)
1961894	Whitten, Anne Starr	Instructional	2	Mid-Level English 6-9 (2850)	Instructional 2 Mid-Level English 6-9 (2850)
1961894	Whitten, Anne Starr	Instructional	2	Mid-Level Citiz. Ed 6-9 (2870)	Instructional 2 Mid-Level Citiz. Ed 6-9 (2870)
6597585	Widdop, Christen Barbara	Instructional	2	Elementary K-6 (2810)	Instructional 2 Elementary K-6 (2810)
6597585	Widdop, Christen Barbara	Instructional	2	Special Education PK-12 (9225)	Instructional 2 Special Education PK-12 (9225)
4914824	Widlund, Shari Rachel	Instructional	2	Elementary K-6 (2810)	Instructional 2 Elementary K-6 (2810)
4914824	Widlund, Shari Rachel	Instructional	HOUSSE	Mid-Level English 6-9 (2850)	Instructional HOUSSE Designation Mid-Level English 6-9 (2850)
4914824	Widlund, Shari Rachel	Instructional	2	Mid-Level English 6-9 (2850)	Instructional 2 Mid-Level English 6-9 (2850)

State ID	Employee Name	Certificate Type	Level Code	Certificate Description	
4914824	Widlund, Shari Rachel	Instructional	HOUSSE	English 7-12 (3230)	Instructional HOUSSE Designation English 7-12 (3230)
4914824	Widlund, Shari Rachel	Instructional	2	Special Education PK-12 (9225)	Instructional 2 Special Education PK-12 (9225)
1735273	Williams, Kristina J	Instructional	2	Elementary K-6 (2810)	Instructional 2 Elementary K-6 (2810)
6109496	Williams, Marie	Administrative	1	Principal PK-12 (1115)	Administrative 1 Principal PK-12 (1115)
6109496	Williams, Marie	Instructional	2	Mathematics 7-12 (6800)	Instructional 2 Mathematics 7-12 (6800)
9083653	Williams, Rhonda Shellenberger	Administrative	1	Principal PK-12 (1115)	Administrative 1 Principal PK-12 (1115)
9083653	Williams, Rhonda Shellenberger	Instructional	2	Elementary K-6 (2810)	Instructional 2 Elementary K-6 (2810)
9083653	Williams, Rhonda Shellenberger	Instructional	2	Early Childhood N-3 (2840)	Instructional 2 Early Childhood N-3 (2840)
9083653	Williams, Rhonda Shellenberger	Instructional	2	Mid-Level English 6-9 (2850)	Instructional 2 Mid-Level English 6-9 (2850)
9083653	Williams, Rhonda Shellenberger	Instructional	2	English 7-12 (3230)	Instructional 2 English 7-12 (3230)
9083653	Williams, Rhonda Shellenberger	Instructional	2	Family-Consumer Sci PK-12 (5600)	Instructional 2 Family-Consumer Sci PK-12 (5600)
9083653	Williams, Rhonda Shellenberger	Instructional	2	Social Studies 7-12 (8875)	Instructional 2 Social Studies 7-12 (8875)
1767502	Willis, Shayna McCracken	Instructional	1	Mathematics 7-12 (6800)	Instructional 1 Mathematics 7-12 (6800)
1917905	Wilson, Lauren	Administrative	1	Principal PK-12 (1115)	Administrative 1 Principal PK-12 (1115)
1917905	Wilson, Lauren	Endorsement		Instructional Coach PK-12 (1182)	Endorsement Instructional Coach PK-12 (1182)
1917905	Wilson, Lauren	Instructional	2	Elementary K-6 (2810)	Instructional 2 Elementary K-6 (2810)
1917905	Wilson, Lauren	Instructional	2	Mid-Level Mathematics 6-9 (2860)	Instructional 2 Mid-Level Mathematics 6-9 (2860)
1917905	Wilson, Lauren	Instructional	2	Reading Specialist PK-12 (7650)	Instructional 2 Reading Specialist PK-12 (7650)
3060541	Wilson, Lynn A	Administrative	1	Principal PK-12 (1115)	Administrative 1 Principal PK-12 (1115)
3060541	Wilson, Lynn A	Instructional	2	Elementary K-6 (2810)	Instructional 2 Elementary K-6 (2810)
3060541	Wilson, Lynn A	Instructional	2	Mid-Level English 6-9 (2850)	Instructional 2 Mid-Level English 6-9 (2850)
3060541	Wilson, Lynn A	Instructional	2	English 7-12 (3230)	Instructional 2 English 7-12 (3230)
5179051	Wilson, Misty L	Instructional	1	English 7-12 (3230)	Instructional 1 English 7-12 (3230)
2786425	Wise, Ashley R	Instructional	2	Elementary K-6 (2810)	Instructional 2 Elementary K-6 (2810)
4652602	Witman, Morgan Rae	Instructional	2	English 7-12 (3230)	Instructional 2 English 7-12 (3230)
4652602	Witman, Morgan Rae	Supervisory		Supvr Special Education PK-12 (9215)	Supervisory Supvr Special Education PK-12 (9215)
4652602	Witman, Morgan Rae	Instructional	2	Special Education PK-12 (9225)	Instructional 2 Special Education PK-12 (9225)
1850535	Witmer, Lauren G	Instructional	2	Elementary K-6 (2810)	Instructional 2 Elementary K-6 (2810)
1850535	Witmer, Lauren G	Instructional	2	Early Childhood N-3 (2840)	Instructional 2 Early Childhood N-3 (2840)
3102191	Worrell, Kimberly A	Instructional	2	Mathematics 7-12 (6800)	Instructional 2 Mathematics 7-12 (6800)
5847123	Wright, Kathleen Ann	Endorsement		Instructional Coach PK-12 (1182)	Endorsement Instructional Coach PK-12 (1182)
5847123	Wright, Kathleen Ann	Private School - Asst or Teacher		Nursery/Kindergarten N-K (12833)	Private School - Asst or Teacher Nursery/Kindergarten N-K (12833)
5847123	Wright, Kathleen Ann	Instructional	2	Elementary K-6 (2810)	Instructional 2 Elementary K-6 (2810)
5847123	Wright, Kathleen Ann	Instructional	2	Early Childhood N-3 (2840)	Instructional 2 Early Childhood N-3 (2840)
	Wrigley, Christopher S	Instructional	1	Elementary K-6 (2810)	Instructional 1 Elementary K-6 (2810)
7191053	Yadsko, Alexandria EmilyAnn	Instructional	1	Grades PK-4 (2825)	Instructional 1 Grades PK-4 (2825)
3059573	Yeager, Paola P	Instructional	1	Reading Specialist PK-12 (7650)	Instructional 1 Reading Specialist PK-12 (7650)
1787689	Young, Karenann S	Non-Certified Educator Designation		Non-Certified Educator PK-12 (20000)	Non-Certified Educator Designation Non-Certified Educator PK-12 (20000)
6136347	Young, Sasha	Instructional	2	Elementary K-6 (2810)	Instructional 2 Elementary K-6 (2810)
6136347	Young, Sasha	Instructional	2	Special Education PK-12 (9225)	Instructional 2 Special Education PK-12 (9225)
6456018	Zakielarz, Pamela Ashley	Educational Specialist	2	Secondary School Counselor 7-12 (1837)	Educational Specialist 2 Secondary School Counselor 7-12 (1837)
5902961	Zanetti, Holli Ann	Instructional	2	Elementary K-6 (2810)	Instructional 2 Elementary K-6 (2810)
5902961	Zanetti, Holli Ann	Instructional	2	Reading Specialist PK-12 (7650)	Instructional 2 Reading Specialist PK-12 (7650)
2916741	Zeisloft, Roxanne Bogo	Educational Specialist	2	Elementary School Counselor K-6 (1836)	Educational Specialist 2 Elementary School Counselor K-6 (1836)
2916741	Zeisloft, Roxanne Bogo	Educational Specialist	2	Secondary School Counselor 7-12 (1837)	Educational Specialist 2 Secondary School Counselor 7-12 (1837)

State ID	Employee Name	Certificate Type	Level Code	Certificate Description	
3861309	Zellers, Trisha Jane	Instructional		Elementary K-6 (2810)	Instructional Elementary K-6 (2810)
3861309	Zellers, Trisha Jane	Instructional	HOUSSE	English 7-12 (3230)	Instructional HOUSSE Designation English 7-12 (3230)
3861309	Zellers, Trisha Jane	Instructional		Ment and/or Phys Handicapped K-12 (9235)	Instructional Ment and/or Phys Handicapped K-12 (9235)
8725829	Zollman, Jennifer L	Instructional	2	Elementary K-6 (2810)	Instructional 2 Elementary K-6 (2810)
8725829	Zollman, Jennifer L	Instructional	2	Special Education PK-12 (9225)	Instructional 2 Special Education PK-12 (9225)



State ID	Employee Name	Certificate Type	Level Code	Certificate Description
3895818	Aaronson, Michelina M	Instructional	2	Elementary K-6 (2810)
3895818	Aaronson, Michelina M	Instructional	2	Early Childhood N-3 (2840)
7147327	Abel, Keri A	Instructional	2	Elementary K-6 (2810)
7517906	Aber, Laura M	Instructional	2	Elementary K-6 (2810)
7517906	Aber, Laura M	Instructional	2	Family-Consumer Sci PK-12 (5600)
7517906	Aber, Laura M	Instructional	2	Reading Specialist PK-12 (7650)
7517906	Aber, Laura M	Instructional	2	Ment and/or Phys Handicapped K-12 (9235)
8947683	Abul Ela, Christina C	Instructional	2	Mathematics 7-12 (6800)
8947683	Abul Ela, Christina C	Instructional	2	Chemistry 7-12 (8420)
9413189	Acland, Kathrine Rita	Instructional	2	Bus-Computer-Info Tech PK-12 (1603)
9413189	Acland, Kathrine Rita	Instructional	2	English 7-12 (3230)
9413189	Acland, Kathrine Rita	Instructional	2	Mathematics 7-12 (6800)
9413189	Acland, Kathrine Rita	Instructional	2	Biology 7-12 (8405)
9413189	Acland, Kathrine Rita	Instructional	2	Social Studies 7-12 (8875)
9413189	Acland, Kathrine Rita	Instructional	2	Special Education PK-12 (9225)
1524186	Adams, Rebecca Rose	Endorsement	1	Instructional Coach PK-12 (1182)
1524186	Adams, Rebecca Rose	Instructional	2	Mid-Level Mathematics 6-9 (2860)
6237909	Adams, Serena Renee	Instructional	1	Grades 4-8 (All subjects 4-6 ELA & Reading (3100)
6237909	Adams, Serena Renee	Instructional	1	Special Education PK-8 (9226)
6237909	Adams, Serena Renee	Instructional	1	Special Education Expansion 7-12 (9229)
9170369	Adrienne, Jennifer Kathleen	Instructional	2	Social Studies 7-12 (8875)
9298295	Alcorn, Ashley Elizabeth-Nicol	Instructional	1	Grades PK-4 (2825)
7984937	Alcott, Elyse M	Instructional	1	Elementary K-6 (2810)
7327629	Alderson, Jordan M	Private School - Teacher		English: Sec. Ed. 9-12 (13230)
7327629	Alderson, Jordan M	Instructional	1	Communications 7-12 (3200)
7327629	Alderson, Jordan M	Instructional	1	English 7-12 (3230)
4621512	Allcorn, Brynne Nadine	Instructional	2	Spanish PK-12 (4490)
5168579	Allen, Betty A	Administrative	2	Principal PK-12 (1115)
5168579	Allen, Betty A	Instructional	2	Elementary K-6 (2810)
5168579	Allen, Betty A	Instructional	2	Mid-Level English 6-9 (2850)
5168579	Allen, Betty A	Instructional	2	Reading Specialist PK-12 (7650)
6813572	Altman, Dorry Ann	Instructional	2	English 7-12 (3230)
8328516	Ambrose, Danielle	Educational Specialist	2	Secondary School Counselor 7-12 (1837)
2941592	Ambuka, Tracey	Instructional	2	Mid-Level Mathematics 6-9 (2860)
2941592	Ambuka, Tracey	Instructional	2	Family-Consumer Sci PK-12 (5600)
2941592	Ambuka, Tracey	Instructional	HOUSSE Designation	Mathematics 7-12 (6800)
2941592	Ambuka, Tracey	Instructional	2	Ment and/or Phys Handicapped K-12 (9235)
5415087	Amodeo, Kattreena Julia	Instructional	2	Elementary K-6 (2810)

State ID	Employee Name	Certificate Type	Level Code	Certificate Description
5415087	Amodeo, Kattreena Julia	Instructional	2	Early Childhood N-3 (2840)
5415087	Amodeo, Kattreena Julia	Program Specialist		English as a Second Language (ESL) PK-12 (4499)
5415087	Amodeo, Kattreena Julia	Instructional	2	Reading Specialist PK-12 (7650)
5415087	Amodeo, Kattreena Julia	Instructional	2	Special Education PK-12 (9225)
7145246	Anderson, Aisha N	Instructional	2	English 7-12 (3230)
7867191	Andrews, Lori Ann	Administrative	1	Principal PK-12 (1115)
7867191	Andrews, Lori Ann	Instructional	2	Mathematics 7-12 (6800)
2394931	Angelo, Shannon Lynn	Administrative	1	Principal PK-12 (1115)
2394931	Angelo, Shannon Lynn	Instructional	2	Elementary K-6 (2810)
6974651	Arcuri, Camille Lynn	Instructional	2	Elementary K-6 (2810)
6974651	Arcuri, Camille Lynn	Instructional	2	Special Education PK-12 (9225)
1830841	Armstrong, Amanda K	Endorsement		Online Instruction Program PK-12 (1184)
1830841	Armstrong, Amanda K	Instructional	2	Elementary K-6 (2810)
1830841	Armstrong, Amanda K	Instructional	2	Mid-Level Mathematics 6-9 (2860)
1830841	Armstrong, Amanda K	Instructional	2	Mid-Level Science 6-9 (2880)
1830841	Armstrong, Amanda K	Instructional	2	Mathematics 7-12 (6800)
1830841	Armstrong, Amanda K	Instructional	2	Biology 7-12 (8405)
1830841	Armstrong, Amanda K	Instructional	2	Special Education PK-12 (9225)
7279386	Atwood, Marlee Anna	Instructional	1	Health & Physical Educ PK-12 (4805)
7279386	Atwood, Marlee Anna	Instructional	1	Special Education PK-8 (9226)
3865179	Baird, Ryan D	Educational Specialist	1	Inst Technology Specialist PK-12 (1825)
3865179	Baird, Ryan D	Instructional	2	Biology 7-12 (8405)
3695945	Baker, Andrea Marie	Instructional	1	Elementary K-6 (2810)
3695945	Baker, Andrea Marie	Instructional	1	Family-Consumer Sci PK-12 (5600)
3695945	Baker, Andrea Marie	Instructional	1	Reading Specialist PK-12 (7650)
6760832	Baker, Christian	Instructional	2	English 7-12 (3230)
6760832	Baker, Christian	Instructional	2	Special Education PK-12 (9225)
8750701	Balliet, Taylor Aisha	Instructional	1	Grades 4-8 (All subjects 4-6 Math 7-8) (3100)
8750701	Balliet, Taylor Aisha	Instructional	1	Grades 4-8 (All subjects 4-6, S Stud 7-8) (3100SS)
8750701	Balliet, Taylor Aisha	Instructional	1	Social Studies 7-12 (8875)
8347132	Baranoski, Anna M	Instructional	2	Grades PK-4 (2825)
8347132	Baranoski, Anna M	Instructional	2	Special Education PK-8 (9226)
5973673	Barber, Constance	Instructional	2	Grades PK-4 (2825)
5973673	Barber, Constance	Instructional	2	Reading Specialist PK-12 (7650)
8071286	Barger, Tammy M	Instructional	2	General Science 7-12 (8450)
6327305	Bargerstock, Whitney E	Instructional	2	Art PK-12 (1405)
6327305	Bargerstock, Whitney E	Instructional	2	English 7-12 (3230)
6327305	Bargerstock, Whitney E	Supervisory		Supvr Special Education PK-12 (9215)

State ID	Employee Name	Certificate Type	Level Code	Certificate Description
6327305	Bargerstock, Whitney E	Instructional	2	Special Education PK-12 (9225)
8908467	Barney, Christine J	Instructional	2	Social Studies 7-12 (8875)
7903076	Barney, Dana Jane	Instructional	1	Art PK-12 (1405)
7903076	Barney, Dana Jane	Instructional	1	English 7-12 (3230)
4590197	Barnhart, Jessica Maria	Instructional	2	Elementary K-6 (2810)
4590197	Barnhart, Jessica Maria	Instructional	2	Special Education PK-12 (9225)
2439473	Barrett, Amy L	Instructional	2	Elementary K-6 (2810)
2439473	Barrett, Amy L	Instructional	2	Mid-Level Mathematics 6-9 (2860)
2439473	Barrett, Amy L	Instructional	2	Mid-Level Science 6-9 (2880)
5029476	Barrett, Kristin D	Instructional	2	Social Studies 7-12 (8875)
8984271	Barrios, Jennifer A	Educational Specialist	2	Home and School Visitor PK-12 (1850)
8984271	Barrios, Jennifer A	Educational Specialist	2	School Social Worker PK-12 (1851)
6512461	Bartuska, Rebecca Sowa	Educational Specialist	1	Secondary School Counselor 7-12 (1837)
6512461	Bartuska, Rebecca Sowa	Instructional	2	Mathematics 7-12 (6800)
6512461	Bartuska, Rebecca Sowa	Instructional	2	Physics 7-12 (8470)
1653853	Bash, Theresa Ann	Instructional	1	Elementary K-6 (2810)
1653853	Bash, Theresa Ann	Instructional	1	Special Education PK-8 (9226)
6941361	Basso, Maura J	Instructional	2	Elementary K-6 (2810)
6941361	Basso, Maura J	Instructional	2	Special Education PK-12 (9225)
6943929	Baxter, Jenna Laken	Instructional	1	Grades PK-4 (2825)
5702327	Bayly, Angela Michelle	Endorsement		Instructional Coach PK-12 (1182)
5702327	Bayly, Angela Michelle	Instructional	2	Communications 7-12 (3200)
5702327	Bayly, Angela Michelle	Instructional	2	English 7-12 (3230)
7318716	Beadle, Karla Marie	Instructional	2	Early Childhood N-3 (2840)
7318716	Beadle, Karla Marie	Instructional	2	Special Education PK-12 (9225)
5981523	Bedor, Gabrielle Ann	Educational Specialist	1	Inst Technology Specialist PK-12 (1825)
5981523	Bedor, Gabrielle Ann	Instructional	2	English 7-12 (3230)
5981523	Bedor, Gabrielle Ann	Instructional	2	Environmental Educ PK-12 (4820)
5981523	Bedor, Gabrielle Ann	Instructional	2	Technology Education PK-12 (6075)
5981523	Bedor, Gabrielle Ann	Instructional	2	Biology 7-12 (8405)
5981523	Bedor, Gabrielle Ann	Instructional	2	General Science 7-12 (8450)
1431604	Beeken, Jennifer A	Instructional	2	English 7-12 (3230)
1431604	Beeken, Jennifer A	Instructional	2	Special Education PK-12 (9225)
4031937	Behm, Haddie Lauren	Instructional	2	Elementary K-6 (2810)
4031937	Behm, Haddie Lauren	Instructional	2	Reading Specialist PK-12 (7650)
4031937	Behm, Haddie Lauren	Instructional	2	Special Education PK-12 (9225)
9870941	Berkey, Daniel W	Instructional	2	Technology Education PK-12 (6075)
9870941	Berkey, Daniel W	Instructional	2	Mathematics 7-12 (6800)

State ID	Employee Name	Certificate Type	Level Code	Certificate Description
5978469	Berry, Sharon M	Instructional	2	Elementary K-6 (2810)
5978469	Berry, Sharon M	Instructional	2	Mathematics 7-12 (6800)
3460531	Berstecher, Kelly Ann	Instructional	1	Elementary K-6 (2810)
3460531	Berstecher, Kelly Ann	Instructional	1	Ment and/or Phys Handicapped K-12 (9235)
9563287	Beschizza, Heather Grace	Educational Specialist	1	Elementary School Counselor K-6 (1836)
9563287	Beschizza, Heather Grace	Educational Specialist	1	Secondary School Counselor 7-12 (1837)
9563287	Beschizza, Heather Grace	Instructional	1	Elementary K-6 (2810)
9563287	Beschizza, Heather Grace	Program Specialist		English as a Second Language (ESL) PK-12 (4499)
7353271	Bianconi, Heather Ann	Administrative	2	Principal PK-12 (1115)
7353271	Bianconi, Heather Ann	Instructional	2	Elementary K-6 (2810)
7353271	Bianconi, Heather Ann	Instructional	2	Reading Specialist PK-12 (7650)
3464959	Bilby, Ron J	Instructional	2	Mid-Level Mathematics 6-9 (2860)
3464959	Bilby, Ron J	Instructional	2	Music PK-12 (7205)
3031572	Binder, Tawny Norma	Instructional	1	Grades PK-4 (2825)
1963475	Bird, Brandon M	Instructional	2	General Science 7-12 (8450)
6059381	Boisvert, Jill	Instructional	2	Bus-Computer-Info Tech PK-12 (1603)
6059381	Boisvert, Jill	Private School - Teacher		Mathematics: Sec. Ed. 9-12 (16800)
6059381	Boisvert, Jill	Instructional	2	Mathematics 7-12 (6800)
7269024	Boisvert, Melody Rae	Instructional	1	Grades PK-4 (2825)
8459568	Bonniger, Samantha AnnMyers	Instructional	2	Special Education PK-12 (9225)
2832436	Bost, Carissa Marie	Instructional	1	English 7-12 (3230)
2832436	Bost, Carissa Marie	Emergency Permit:		Day-to-Day Sub All Instructional Areas PK-12 (96)
9294146	Botti, Michelle	Instructional	1	Grades PK-4 (2825)
9294146	Botti, Michelle	Instructional	1	Grades 4-8 (All subjects 4-6 ELA & Reading (3100)
9294146	Botti, Michelle	Instructional	1	Special Education PK-8 (9226)
1930918	Bowie, Nicole E	Instructional	2	Health & Physical Educ PK-12 (4805)
5358072	Boyer, Cathy Marie	Instructional	2	Mathematics 7-12 (6800)
5358072	Boyer, Cathy Marie	Instructional	2	Special Education PK-12 (9225)
1302864	Boyer, Jessica Leigh	Instructional	2	Elementary K-6 (2810)
7018432	Boyle, Jarin Tomas	Instructional	1	Grades PK-4 (2825)
8028262	Brand, Catherine	Instructional	1	Elementary K-6 (2810)
8028262	Brand, Catherine	Instructional	1	Mid-Level Mathematics 6-9 (2860)
4295652	Bray, Christopher	Instructional	2	Bus-Computer-Info Tech PK-12 (1603)
4295652	Bray, Christopher	Instructional	2	Elementary K-6 (2810)
4295652	Bray, Christopher	Instructional	2	Mid-Level English 6-9 (2850)
4295652	Bray, Christopher	Instructional	2	Mid-Level Citiz. Ed 6-9 (2870)
4295652	Bray, Christopher	Instructional	2	Mid-Level Science 6-9 (2880)
4295652	Bray, Christopher	Instructional	2	Family-Consumer Sci PK-12 (5600)

State ID	Employee Name	Certificate Type	Level Code	Certificate Description
4295652	Bray, Christopher	Instructional	2	Technology Education PK-12 (6075)
2602809	Brennan, Jean Marie	Instructional	2	Elementary K-6 (2810)
8491596	Brestensky, Lisa	Instructional	2	Elementary K-6 (2810)
8491596	Brestensky, Lisa	Instructional	2	Ment and/or Phys Handicapped K-12 (9235)
3602713	Breyak, Laurel	Instructional	1	Elementary K-6 (2810)
8795053	Briley, Christie Leighann	Instructional	1	Grades PK-4 (2825)
3612063	Brisbane, Amber	Instructional	2	Elementary K-6 (2810)
3612063	Brisbane, Amber	Instructional	2	Special Education PK-12 (9225)
8308973	Brohi, Heba H	Instructional	2	Elementary K-6 (2810)
8308973	Brohi, Heba H	Instructional	2	Mathematics 7-12 (6800)
8302961	Broniszewski, Diane	Instructional	2	French PK-12 (4410)
8302961	Broniszewski, Diane	Instructional	2	Spanish PK-12 (4490)
8439368	Bronson, Angelica Lauren	Instructional	1	Grades PK-4 (2825)
6168378	Brown, Brittany Marie	Endorsement		Autism PK-12 (1180)
6168378	Brown, Brittany Marie	Instructional	1	Grades PK-4 (2825)
6168378	Brown, Brittany Marie	Instructional	1	Special Education PK-8 (9226)
8537103	Brown, Kathleen A	Instructional	2	Accounting 7-12 (1610)
8537103	Brown, Kathleen A	Instructional	2	Marketing 7-12 (1640)
8537103	Brown, Kathleen A	Instructional	2	Office Technologies 7-12 (1658)
7027624	Brown, Laura Allison	Instructional	1	Elementary K-6 (2810)
7027624	Brown, Laura Allison	Instructional	1	Grades PK-4 (2825)
2141631	Brown, Sarah C	Instructional	2	Biology 7-12 (8405)
2141631	Brown, Sarah C	Instructional	2	Chemistry 7-12 (8420)
9169278	Brownlie, Victoria Eugenia	Instructional	2	Spanish PK-12 (4490)
1269132	Brucker, Antoinette M	Instructional	2	Special Education PK-12 (9225)
9423031	Bruenn, Matthew J	Instructional	1	Mathematics 7-12 (6800)
9423031	Bruenn, Matthew J	Instructional	1	Earth and Space Science 7-12 (8440)
9423031	Bruenn, Matthew J	Instructional	1	General Science 7-12 (8450)
6408509	Bryan, Carol L	Instructional	2	Elementary K-6 (2810)
6408509	Bryan, Carol L	Instructional	2	Special Education PK-12 (9225)
8360894	Bryson, Jocelyn S	Instructional	2	Elementary K-6 (2810)
8360894	Bryson, Jocelyn S	Instructional	2	Special Education PK-12 (9225)
8726136	Buck, Jill	Instructional	1	Elementary K-6 (2810)
5038104	Buckwalter, Jodeen E	Instructional	HOUSSE Designation	English 7-12 (3230)
5038104	Buckwalter, Jodeen E	Instructional	HOUSSE Designation	Mathematics 7-12 (6800)
5038104	Buckwalter, Jodeen E	Instructional	HOUSSE Designation	General Science 7-12 (8450)
5038104	Buckwalter, Jodeen E	Instructional	HOUSSE Designation	Social Studies 7-12 (8875)
5038104	Buckwalter, Jodeen E	Instructional	2	Ment and/or Phys Handicapped K-12 (9235)

State ID	Employee Name	Certificate Type	Level Code	Certificate Description
1419058	Buffington, Eric G	Administrative	1	Principal PK-12 (1115)
1419058	Buffington, Eric G	Instructional	2	Elementary K-6 (2810)
1419058	Buffington, Eric G	Instructional	2	Mid-Level Mathematics 6-9 (2860)
1419058	Buffington, Eric G	Instructional	2	Mid-Level Science 6-9 (2880)
1419058	Buffington, Eric G	Instructional	2	English 7-12 (3230)
	Bui, Tyler Hung	Instructional	2	Elementary K-6 (2810)
	Bunn, Jeffrey H	Instructional	1	Elementary K-6 (2810)
5934353	Burke, Jonna Huemrich	Instructional		Elementary K-6 (2810)
4703501	Burns, Ashley Elizabeth	Instructional	2	Elementary K-6 (2810)
4703501	Burns, Ashley Elizabeth	Instructional	2	Mid-Level English 6-9 (2850)
4703501	Burns, Ashley Elizabeth	Instructional	2	Reading Specialist PK-12 (7650)
5732496	Buss, Jennifer Ann	Instructional	HOUSSE Designation	Elementary K-6 (2810)
5732496	Buss, Jennifer Ann	Instructional	2	Special Education PK-12 (9225)
5732496	Buss, Jennifer Ann	Instructional	2	Speech & Language Impaired PK-12 (9265)
1023958	Butera, Maryann	Instructional	1	Elementary K-6 (2810)
1023958	Butera, Maryann	Instructional	1	Reading Specialist PK-12 (7650)
1023958	Butera, Maryann	Instructional	1	Special Education PK-12 (9225)
8539581	Butler, Anne M	Instructional	2	Grades PK-4 (2825)
8539581	Butler, Anne M	Instructional	2	Grades 4-8 (All subjects 4-6 ELA & Reading (3100)
8539581	Butler, Anne M	Instructional	2	English 7-12 (3230)
8539581	Butler, Anne M	Instructional	2	Reading Specialist PK-12 (7650)
6028562	Byers, Colien Joanne	Supervisory		Supvr Special Education PK-12 (9215)
6028562	Byers, Colien Joanne	Instructional	2	Special Education PK-12 (9225)
2746171	Cadieus, Jennifer	Instructional	1	Special Education PK-12 (9225)
2946235	Cadwallader, Amy Beth	Instructional	2	Mathematics 7-12 (6800)
8793961	Calton, April Lynne	Instructional	2	Mid-Level Mathematics 6-9 (2860)
8793961	Calton, April Lynne	Instructional	2	Biology 7-12 (8405)
8793961	Calton, April Lynne	Instructional	2	Chemistry 7-12 (8420)
8793961	Calton, April Lynne	Instructional	2	General Science 7-12 (8450)
1524281	Camaioni, Nicole	Instructional	2	Bus-Computer-Info Tech PK-12 (1603)
1524281	Camaioni, Nicole	Instructional	2	English 7-12 (3230)
1524281	Camaioni, Nicole	Instructional	2	Library Science PK-12 (6420)
1524281	Camaioni, Nicole	Instructional	2	Social Studies 7-12 (8875)
8727359	Camarda, Kate Virginia	Instructional	2	Elementary K-6 (2810)
8727359	Camarda, Kate Virginia	Instructional	2	Mid-Level Mathematics 6-9 (2860)
8727359	Camarda, Kate Virginia	Instructional	2	English 7-12 (3230)
8727359	Camarda, Kate Virginia	Program Specialist		English as a Second Language (ESL) PK-12 (4499)
1037354	Campbell, Elizabeth Hope	Instructional	1	Grades PK-4 (2825)

State ID	Employee Name	Certificate Type	Level Code	Certificate Description
1037354	Campbell, Elizabeth Hope	Instructional	1	Grades 5-6 (2826)
4171219	Canonge, Andrea Lauren	Instructional	1	Elementary K-6 (2810)
6989082	Cantwell, Brittney Taylor	Instructional	2	Elementary K-6 (2810)
6989082	Cantwell, Brittney Taylor	Instructional	2	Special Education PK-8 (9226)
8981801	Capitano, Jesse C	Instructional	2	Special Education PK-12 (9225)
9813569	Carmichael, Rachel Marie	Instructional	2	Elementary K-6 (2810)
9813569	Carmichael, Rachel Marie	Instructional	2	Special Education PK-12 (9225)
5152913	Carr, Jocelyn Rayel	Instructional	2	Elementary K-6 (2810)
5152913	Carr, Jocelyn Rayel	Instructional	2	Special Education PK-12 (9225)
2896206	Carver, Jeremy M	Instructional	2	Elementary K-6 (2810)
2896206	Carver, Jeremy M	Instructional	2	Mid-Level English 6-9 (2850)
2896206	Carver, Jeremy M	Instructional	2	Mid-Level Mathematics 6-9 (2860)
2896206	Carver, Jeremy M	Instructional	2	Mid-Level Science 6-9 (2880)
6739749	Cashman, Sandy	Instructional	1	Elementary K-6 (2810)
5696493	Castillon McCarty, Arturo	Instructional	1	Social Studies 7-12 (8875)
6121506	Center, Tina	Instructional	1	Spanish PK-12 (4490)
9075298	Chaffin, Casey	Instructional	1	Grades PK-4 (2825)
9075298	Chaffin, Casey	Instructional	1	Special Education PK-8 (9226)
1861738	Chiado, Nicole Lynn	Instructional	1	Grades PK-4 (2825)
1861738	Chiado, Nicole Lynn	Instructional	1	Special Education PK-8 (9226)
5140418	Christmas, Stacy D	Instructional	2	Elementary K-6 (2810)
8090325	Ciarlone, Shannon	Instructional	2	Early Childhood N-3 (2840)
7681605	Clagett, David C	Instructional	2	Social Studies 7-12 (8875)
7854979	Clark, Susan S	Instructional	2	Reading Specialist PK-12 (7650)
7854979	Clark, Susan S	Instructional	2	Social Studies 7-12 (8875)
4102713	Cobert, Heather Leann	Instructional	2	Elementary K-6 (2810)
4102713	Cobert, Heather Leann	Instructional	2	English 7-12 (3230)
4102713	Cobert, Heather Leann	Instructional	2	Special Education PK-12 (9225)
1928429	Coen, Nicole Lyndsey	Instructional	1	Elementary K-6 (2810)
5086528	Compton, Nancy Lee	Educational Specialist	1	School Social Worker PK-12 (1851)
5045706	Congdon, Rebekah Lynne	Instructional	HOUSSE Designation	Elementary K-6 (2810)
5045706	Congdon, Rebekah Lynne	Instructional	2	Elementary K-6 (2810)
5045706	Congdon, Rebekah Lynne	Instructional	2	Ment and/or Phys Handicapped K-12 (9235)
7576873	Connelly, Jennifer Marie	Instructional	2	Elementary K-6 (2810)
7576873	Connelly, Jennifer Marie	Instructional	2	Reading Specialist PK-12 (7650)
7576873	Connelly, Jennifer Marie	Instructional	2	Special Education PK-12 (9225)
2614786	Connor, Erin Rose	Instructional	1	Grades PK-4 (2825)
2614786	Connor, Erin Rose	Instructional	1	Special Education PK-8 (9226)

State ID	Employee Name	Certificate Type	Level Code	Certificate Description
9384068	Conway, Meredith Dance	Instructional	2	Elementary K-6 (2810)
9384068	Conway, Meredith Dance	Instructional	2	Mid-Level English 6-9 (2850)
9384068	Conway, Meredith Dance	Instructional	2	Mid-Level Mathematics 6-9 (2860)
9384068	Conway, Meredith Dance	Instructional	2	Mid-Level Science 6-9 (2880)
9384068	Conway, Meredith Dance	Instructional	2	Special Education PK-12 (9225)
6179747	Cooper, Barbara J	Instructional	2	Elementary K-6 (2810)
6179747	Cooper, Barbara J	Instructional	2	Special Education PK-12 (9225)
6341707	Cooper, Laura J	Instructional	1	Elementary K-6 (2810)
4679237	Cortes, Alona Jean	Instructional	1	Grades PK-4 (2825)
4721493	Costanzo, Kristal	Instructional	2	Elementary K-6 (2810)
4721493	Costanzo, Kristal	Instructional	2	Special Education PK-12 (9225)
6364271	Cox, Brianne	Instructional	1	Elementary K-6 (2810)
6364271	Cox, Brianne	Instructional	1	Mid-Level Mathematics 6-9 (2860)
4706023	Coyne, Heather Marie	Instructional	2	Mid-Level Science 6-9 (2880)
4706023	Coyne, Heather Marie	Instructional	2	Environmental Educ PK-12 (4820)
4706023	Coyne, Heather Marie	Instructional	2	Biology 7-12 (8405)
4706023	Coyne, Heather Marie	Instructional	2	General Science 7-12 (8450)
7931508	Cragle, Caleb James	Instructional	2	Bus-Computer-Info Tech PK-12 (1603)
7931508	Cragle, Caleb James	Instructional	2	Mid-Level Mathematics 6-9 (2860)
7931508	Cragle, Caleb James	Instructional	2	Biology 7-12 (8405)
7931508	Cragle, Caleb James	Instructional	2	General Science 7-12 (8450)
5862824	Cramer, Shila Ellyn	Instructional	2	General Science 7-12 (8450)
6282358	Creaven, Melissa	Instructional	2	Elementary K-6 (2810)
6282358	Creaven, Melissa	Instructional	2	Early Childhood N-3 (2840)
1637383	Cross, Amber Faith	Instructional	2	Elementary K-6 (2810)
2427256	Cukauskas, Michelle Elizabeth	Private School - Asst or Teacher		Nursery/Kindergarten N-K (12833)
2427256	Cukauskas, Michelle Elizabeth	Instructional	2	Elementary K-6 (2810)
2427256	Cukauskas, Michelle Elizabeth	Supervisory		Supvr Special Education PK-12 (9215)
2427256	Cukauskas, Michelle Elizabeth	Instructional	2	Ment and/or Phys Handicapped K-12 (9235)
2804139	Curry, Denise Michele	Endorsement	Endorcement	Instructional Coach PK-12 (1182)
2804139	Curry, Denise Michele	Private School - Asst or Teacher		Nursery/Kindergarten N-K (12833)
2804139	Curry, Denise Michele	Instructional	1	Elementary K-6 (2810)
2804139	Curry, Denise Michele	Instructional	1	Early Childhood N-3 (2840)
3672897	Cuviello, Grace	Instructional	1	Grades PK-4 (2825)
6943508	Dalessandri-Fetterman, Melissa E	Instructional	2	Elementary K-6 (2810)
6943508	Dalessandri-Fetterman, Melissa E	Instructional	2	Special Education PK-12 (9225)
9759372	Dannaker, Doris	Instructional	1	Elementary K-6 (2810)
9759372	Dannaker, Doris	Instructional	1	Mid-Level Mathematics 6-9 (2860)



State ID	Employee Name	Certificate Type	Level Code	Certificate Description
4867954	Davis, Megan Lynn	Instructional	1	Elementary K-6 (2810)
6574183	Davish, Noreen R	Instructional	2	Mid-Level Mathematics 6-9 (2860)
6574183	Davish, Noreen R	Instructional	2	Music PK-12 (7205)
6284705	Dearwester, Mia Alexandra	Instructional	1	Reading Specialist PK-12 (7650)
6284705	Dearwester, Mia Alexandra	Instructional	1	Special Education PK-8 (9226)
9328097	Deemer, Judith	Instructional	2	Elementary K-6 (2810)
9328097	Deemer, Judith	Instructional	2	Ment and/or Phys Handicapped K-12 (9235)
8072495	Deemer, Melissa Rebecca	Instructional	1	Grades 4-8 (All subjects 4-6 Math 7-8) (3100)
9562753	DeFelice, Amanda Elaine	Instructional	1	Grades 4-8 (All subjects 4-6 ELA & Reading) (3100)
9562753	DeFelice, Amanda Elaine	Instructional	1	English 7-12 (3230)
6017637	Deloe, Anita J	Instructional	2	Mid-Level Mathematics 6-9 (2860)
6017637	Deloe, Anita J	Instructional	2	Mid-Level Science 6-9 (2880)
6017637	Deloe, Anita J	Instructional	2	Safety Ed/Driver Ed 7-12 (5215)
6017637	Deloe, Anita J	Instructional	2	Citizenship 7-12 (8825)
6017637	Deloe, Anita J	Instructional	2	Social Studies 7-12 (8875)
5837679	Denham, Angela M	Instructional	2	Elementary K-6 (2810)
5837679	Denham, Angela M	Instructional	2	Ment and/or Phys Handicapped K-12 (9235)
1051274	DePietro, Jennifer	Instructional	1	Elementary K-6 (2810)
1051274	DePietro, Jennifer	Instructional	1	Early Childhood N-3 (2840)
1051274	DePietro, Jennifer	Instructional	1	Special Education PK-12 (9225)
2349318	Devine Owen, Erin L	Educational Specialist	2	School Nurse PK-12 (1890)
6495832	Devinney, Sara O	Private School - Asst or Teacher		Nursery/Kindergarten N-K (12833)
6495832	Devinney, Sara O	Instructional	2	Art PK-12 (1405)
6495832	Devinney, Sara O	Instructional	2	Elementary K-6 (2810)
6495832	Devinney, Sara O	Instructional	2	Early Childhood N-3 (2840)
5267479	Di Martini, Danielle J	Private School - Asst or Teacher		Nursery/Kindergarten N-K (12833)
5267479	Di Martini, Danielle J	Instructional	2	Elementary K-6 (2810)
5267479	Di Martini, Danielle J	Instructional	2	Reading Specialist PK-12 (7650)
5267479	Di Martini, Danielle J	Instructional	2	Special Education PK-8 (9226)
4096064	Dietrich, Jenna Lee	Instructional	2	Elementary K-6 (2810)
4096064	Dietrich, Jenna Lee	Instructional	2	Special Education PK-12 (9225)
6716134	Dillon, Anne	Instructional	2	English 7-12 (3230)
5841612	Dimov-Gottshall, Emily Marie	Instructional	1	Art PK-12 (1405)
1051025	DiStefano, Katherine Carole	Instructional	2	Art PK-12 (1405)
2569601	Dodge, Heidi Marie	Private School - Teacher		Elementary Education K-8 (12810)
2569601	Dodge, Heidi Marie	Private School - Asst or Teacher		Nursery/Kindergarten N-K (12833)
2569601	Dodge, Heidi Marie	Instructional	2	Elementary K-6 (2810)
2569601	Dodge, Heidi Marie	Instructional	2	Early Childhood N-3 (2840)

State ID	Employee Name	Certificate Type	Level Code	Certificate Description
2569601	Dodge, Heidi Marie	Instructional	2	Special Education PK-12 (9225)
7489562	Doebereiner, Julie Elizabeth	Instructional	2	Special Education PK-12 (9225)
6316362	Donahue, Lindsey Marie	Instructional	2	Grades PK-4 (2825)
6316362	Donahue, Lindsey Marie	Instructional	2	Grades 4-8 (All subjects 4-6 ELA & Reading (3100)
6316362	Donahue, Lindsey Marie	Instructional	2	Reading Specialist PK-12 (7650)
3813891	Donley, Jason M	Instructional	2	Health & Physical Educ PK-12 (4805)
9453767	Donnelly, Maureen J	Instructional	2	Mid-Level Mathematics 6-9 (2860)
9453767	Donnelly, Maureen J	Instructional	2	Mid-Level Science 6-9 (2880)
9453767	Donnelly, Maureen J	Instructional	2	Earth and Space Science 7-12 (8440)
9453767	Donnelly, Maureen J	Instructional	2	General Science 7-12 (8450)
9764135	Donovan, James M	Clearance		FBI Clearance
6141043	Dorfzaun, Joshua Hiram	Instructional	2	Ment and/or Phys Handicapped K-12 (9235)
8692373	DoVidio, Domenica Rose	Instructional	1	Elementary K-6 (2810)
1585189	Draeger, Theresa M	Instructional	1	Elementary K-6 (2810)
1585189	Draeger, Theresa M	Instructional	1	Special Education PK-12 (9225)
4018743	Dumas, Jennifer A	Instructional	2	Accounting 7-12 (1610)
4018743	Dumas, Jennifer A	Instructional	2	Data Processing 7-12 (1625)
4018743	Dumas, Jennifer A	Instructional	2	Marketing 7-12 (1640)
4018743	Dumas, Jennifer A	Instructional	2	Office Technologies 7-12 (1658)
3951391	Dunlap, Jill A	Private School - Teacher		Elementary Education K-8 (12810)
3951391	Dunlap, Jill A	Private School - Teacher		Soc and Emotionally Dist K-12 (19260)
3951391	Dunlap, Jill A	Instructional	2	Elementary K-6 (2810)
3951391	Dunlap, Jill A	Instructional	2	Early Childhood N-3 (2840)
3951391	Dunlap, Jill A	Instructional	HOUSSE Designation	English 7-12 (3230)
3951391	Dunlap, Jill A	Instructional	HOUSSE Designation	Social Studies 7-12 (8875)
3951391	Dunlap, Jill A	Instructional	2	Special Education PK-12 (9225)
9630187	Dupes, Linda D	Instructional	2	Elementary K-6 (2810)
9630187	Dupes, Linda D	Instructional	2	English 7-12 (3230)
5976482	Eberly, Jessica Nicole	Instructional	2	Elementary K-6 (2810)
5976482	Eberly, Jessica Nicole	Instructional	2	Early Childhood N-3 (2840)
1835849	Eckels, Olivia Claire	Instructional	2	Special Education PK-12 (9225)
2169062	Edmundson, Megan Amanda	Instructional	2	English 7-12 (3230)
7032767	Egan, Colleen Denise	Instructional	1	Elementary K-6 (2810)
7306241	Eisenhart, Geralyn T	Instructional	2	Elementary K-6 (2810)
6167926	Ellis, Bridget Marie	Instructional	2	Elementary K-6 (2810)
6167926	Ellis, Bridget Marie	Instructional	2	Special Education PK-12 (9225)
5385905	Elmqvist, Dana Lynn	Educational Specialist	1	School Psychologist PK-12 (1875)
5385905	Elmqvist, Dana Lynn	Instructional	1	Social Studies 7-12 (8875)

State ID	Employee Name	Certificate Type	Level Code	Certificate Description
9614984	Emminger, Lauren Louise	Instructional	1	Social Studies 7-12 (8875)
9614984	Emminger, Lauren Louise	Instructional	1	Special Education 7-12 (9227)
9815743	Emrich, Sherri L	Instructional	2	Elementary K-6 (2810)
9815743	Emrich, Sherri L	Instructional	2	Special Education PK-12 (9225)
5403689	Emrick, Carissa Robyn	Instructional	1	Elementary K-6 (2810)
5403689	Emrick, Carissa Robyn	Instructional	1	Special Education PK-12 (9225)
1493634	Emsurak, Janeen M	Instructional	2	Elementary K-6 (2810)
3848547	Encapera-Teslovich, Joanna	Instructional	2	Elementary K-6 (2810)
3848547	Encapera-Teslovich, Joanna	Instructional	2	Mid-Level Mathematics 6-9 (2860)
3848547	Encapera-Teslovich, Joanna	Instructional	2	Special Education PK-12 (9225)
6278342	England, Emilee Grace	Instructional	1	English 7-12 (3230)
3690615	Erdmann, Melissa	Instructional	2	Elementary K-6 (2810)
3690615	Erdmann, Melissa	Instructional	2	Early Childhood N-3 (2840)
3690615	Erdmann, Melissa	Instructional	2	Mid-Level Mathematics 6-9 (2860)
3690615	Erdmann, Melissa	Instructional	2	Reading Specialist PK-12 (7650)
8578416	Evangelista, Gina A	Instructional	2	English 7-12 (3230)
8578416	Evangelista, Gina A	Instructional	2	Reading Specialist PK-12 (7650)
6897987	Facciolo, Gina Marie	Instructional	1	Elementary K-6 (2810)
2480142	Farster, Ashley Lynne	Instructional	2	Grades PK-4 (2825)
2480142	Farster, Ashley Lynne	Instructional	2	Special Education PK-8 (9226)
1607938	Fecik, Justine Lynn	Educational Specialist	1	Elementary School Counselor K-6 (1836)
1607938	Fecik, Justine Lynn	Educational Specialist	1	Secondary School Counselor 7-12 (1837)
1607938	Fecik, Justine Lynn	Instructional	2	Elementary K-6 (2810)
1607938	Fecik, Justine Lynn	Instructional	2	Special Education PK-12 (9225)
6131985	Feely, Scott L	Instructional	1	Mid-Level Mathematics 6-9 (2860)
6131985	Feely, Scott L	Instructional	1	Mid-Level Science 6-9 (2880)
6131985	Feely, Scott L	Instructional	1	Mathematics 7-12 (6800)
6131985	Feely, Scott L	Instructional	1	Biology 7-12 (8405)
6131985	Feely, Scott L	Instructional	1	General Science 7-12 (8450)
8925806	Feeney Hoffmaster, Shannon Margaret	Instructional	2	Social Studies 7-12 (8875)
8925806	Feeney Hoffmaster, Shannon Margaret	Instructional	2	Special Education PK-12 (9225)
8241017	Fegely, Joy Elaine	Instructional	1	Elementary K-6 (2810)
6747158	Feldhaus, Daniel	Instructional	1	Social Studies 7-12 (8875)
6208603	Ferenchick, Tyler Alexander	Instructional	1	Citizenship 7-12 (8825)
7497828	Ferguson, Ashley Elizabeth	Instructional	2	Elementary K-6 (2810)
7497828	Ferguson, Ashley Elizabeth	Instructional	2	Special Education PK-12 (9225)
6859102	Ferrier, Cassandra L	Instructional	2	Elementary K-6 (2810)
6859102	Ferrier, Cassandra L	Instructional	2	English 7-12 (3230)

State ID	Employee Name	Certificate Type	Level Code	Certificate Description
3536269	Fine, Brianna Lynn	Instructional	1	Grades 4-8 (All subjects 4-6 Math 7-8) (3100)
9671831	Finlayson, Rosalyn	Endorsement		Online Instruction Program PK-12 (1184)
9671831	Finlayson, Rosalyn	Instructional	2	Communications 7-12 (3200)
9671831	Finlayson, Rosalyn	Instructional	2	English 7-12 (3230)
9671831	Finlayson, Rosalyn	Program Specialist		English as a Second Language (ESL) PK-12 (4499)
9671831	Finlayson, Rosalyn	Instructional	2	Reading Specialist PK-12 (7650)
8105219	Fiscus, Grace A	Instructional	2	Grades PK-4 (2825)
8105219	Fiscus, Grace A	Instructional	2	Special Education PK-8 (9226)
3576797	Fiscus, Kimberly Ann	Endorsement	Endorsement	Instructional Coach PK-12 (1182)
3576797	Fiscus, Kimberly Ann	Instructional	2	Special Education 7-12 (9227)
8961729	Fisher Clark, Jennifer Jo	Supervisory		Supvr Special Education PK-12 (9215)
8961729	Fisher Clark, Jennifer Jo	Instructional	2	Ment and/or Phys Handicapped K-12 (9235)
7953824	Fitzgerald, Kimberly A	Instructional	2	Elementary K-6 (2810)
7953824	Fitzgerald, Kimberly A	Instructional	2	Special Education PK-12 (9225)
3219831	Fitzgibbon, Renee	Instructional	2	Elementary K-6 (2810)
3219831	Fitzgibbon, Renee	Instructional	2	Reading Specialist PK-12 (7650)
7192646	Flatley, Jennifer Marie	Instructional	2	Grades PK-4 (2825)
7192646	Flatley, Jennifer Marie	Instructional	2	Reading Specialist PK-12 (7650)
7192646	Flatley, Jennifer Marie	Instructional	2	Special Education PK-8 (9226)
7192646	Flatley, Jennifer Marie	Instructional	1	Special Education Expansion 7-12 (9229)
6978125	Flinchum, Christina Leah	Instructional	2	Social Studies 7-12 (8875)
5689261	Flores, Kayla Lynn	Instructional	1	Elementary K-6 (2810)
5689261	Flores, Kayla Lynn	Instructional	1	Special Education PK-12 (9225)
4891748	Floyd, Michael S	Administrative	1	Secondary Principal 7-12 (1105)
4891748	Floyd, Michael S	Instructional	2	Mid-Level Mathematics 6-9 (2860)
4891748	Floyd, Michael S	Supervisory	1	Supvr Science 7-12 (8415)
4891748	Floyd, Michael S	Instructional	2	General Science 7-12 (8450)
9454898	Folmar, Paul R	Instructional	1	Mathematics 7-12 (6800)
9454898	Folmar, Paul R	Instructional	1	General Science 7-12 (8450)
9454898	Folmar, Paul R	Instructional	1	Physics 7-12 (8470)
9571606	Force, Alison Marie	Supervisory		Supvr Curriculum & Inst PK-12 (2915)
9571606	Force, Alison Marie	Instructional	2	Social Studies 7-12 (8875)
5620596	Forrest, Emily Christine	Instructional	1	Grades PK-4 (2825)
5620596	Forrest, Emily Christine	Instructional	1	Special Education PK-8 (9226)
4904954	Franklin, Melissa Lynn	Instructional	2	Early Childhood N-3 (2840)
4904954	Franklin, Melissa Lynn	Instructional	2	Special Education PK-12 (9225)
7362847	Franks, Laura E	Instructional	2	Elementary K-6 (2810)
7362847	Franks, Laura E	Instructional	2	Special Education PK-12 (9225)

State ID	Employee Name	Certificate Type	Level Code	Certificate Description
8761485	Frederick, Holly Anne	Letter of Equivalency	1	Master's Equivalency - (1185)
8761485	Frederick, Holly Anne	Instructional	2	Grades PK-4 (2825)
8761485	Frederick, Holly Anne	Instructional	2	Grades 4-8 (All subjects 4-6 ELA & Reading (3100)
8761485	Frederick, Holly Anne	Instructional	2	Grades 4-8 (All subjects 4-6 Science 7-8) (3100)
3523082	Freyvogel Bruss, Colleen L	Administrative	1	Principal PK-12 (1115)
3523082	Freyvogel Bruss, Colleen L	Instructional	2	Mid-Level Mathematics 6-9 (2860)
3523082	Freyvogel Bruss, Colleen L	Instructional	2	Communications 7-12 (3200)
3523082	Freyvogel Bruss, Colleen L	Instructional	2	English 7-12 (3230)
3523082	Freyvogel Bruss, Colleen L	Instructional	2	Special Education PK-12 (9225)
5897815	Froehlich, Brittany P	Instructional	2	Elementary K-6 (2810)
5897815	Froehlich, Brittany P	Instructional	2	Mid-Level English 6-9 (2850)
5897815	Froehlich, Brittany P	Instructional	2	Special Education PK-12 (9225)
5839145	Furka, David J	Endorsement		Autism PK-12 (1180)
5839145	Furka, David J	Instructional	2	Elementary K-6 (2810)
5839145	Furka, David J	Program Specialist		English as a Second Language (ESL) PK-12 (4499)
5839145	Furka, David J	Instructional	2	Special Education PK-8 (9226)
7959715	Gallagher, Heather Ann	Instructional	2	Elementary K-6 (2810)
7959715	Gallagher, Heather Ann	Instructional	2	Special Education PK-12 (9225)
8191468	Gallis, Kimberly Ann	Instructional	2	Elementary K-6 (2810)
3606263	Galloway, Kayla Anne	Instructional	1	Elementary K-6 (2810)
3031084	Galonski, Morgan M	Endorsement		Instructional Coach PK-12 (1182)
3031084	Galonski, Morgan M	Instructional	2	Elementary K-6 (2810)
3031084	Galonski, Morgan M	Instructional	2	English 7-12 (3230)
3031084	Galonski, Morgan M	Instructional	2	Reading Specialist PK-12 (7650)
9583478	Galonski, Robert B	Private School - Teacher		Biology: Sec. Ed. 9-12 (18405)
9583478	Galonski, Robert B	Instructional	2	Biology 7-12 (8405)
9583478	Galonski, Robert B	Instructional	2	General Science 7-12 (8450)
2806325	Gannon, Devin Richard	Instructional	1	Elementary K-6 (2810)
2806325	Gannon, Devin Richard	Instructional	1	Special Education PK-12 (9225)
1673067	Ganter, Crysta M	Instructional	2	Grades PK-4 (2825)
1673067	Ganter, Crysta M	Instructional	2	Grades 5-6 (2826)
1673067	Ganter, Crysta M	Instructional	2	Special Education PK-8 (9226)
8048158	Garczynski, Molly E	Private School - Asst or Teacher		Nursery/Kindergarten N-K (12833)
8048158	Garczynski, Molly E	Instructional	2	Elementary K-6 (2810)
8048158	Garczynski, Molly E	Instructional	2	Special Education PK-12 (9225)
1678431	Gasol, Melissa	Private School - Teacher		Soc and Emotionally Dist K-12 (19260)
1678431	Gasol, Melissa	Instructional	2	Special Education PK-12 (9225)
5748249	Gaylord, Callie A	Instructional	2	English 7-12 (3230)

State ID	Employee Name	Certificate Type	Level Code	Certificate Description
4609487	Geiman, Amanda Mae	Instructional	2	Elementary K-6 (2810)
5301637	George, Michelle Beatrice	Instructional	1	Elementary K-6 (2810)
4686739	Gibbons, Ahrin Yvette	Instructional	1	General Science 7-12 (8450)
9589157	Giordano, Kathryn	Educational Specialist	2	School Psychologist PK-12 (1875)
9589157	Giordano, Kathryn	Instructional	1	Elementary K-6 (2810)
3543801	Giovanisci, Katy Veronica	Administrative	1	Principal PK-12 (1115)
3543801	Giovanisci, Katy Veronica	Supervisory	1	Supvr Curriculum & Inst PK-12 (2915)
3543801	Giovanisci, Katy Veronica	Instructional	2	Communications 7-12 (3200)
3543801	Giovanisci, Katy Veronica	Instructional	2	English 7-12 (3230)
4529215	Girard, Karen Danielle	Instructional	2	Elementary K-6 (2810)
4529215	Girard, Karen Danielle	Instructional	2	Ment and/or Phys Handicapped K-12 (9235)
2102439	Goff, Jaelynn Beeler	Instructional	1	English 7-12 (3230)
2102439	Goff, Jaelynn Beeler	Instructional	1	Social Studies 7-12 (8875)
1020343	Goughnour, Lauren Marie	Instructional	2	Mathematics 7-12 (6800)
9278058	Grafton, Brittany Alice	Instructional	1	Grades PK-4 (2825)
9278058	Grafton, Brittany Alice	Instructional	1	Special Education PK-8 (9226)
9278058	Grafton, Brittany Alice	Instructional	1	Special Education Expansion 7-12 (9229)
6326152	Grant, Jamie Marie	Endorsement	Endorsement	Instructional Coach PK-12 (1182)
6326152	Grant, Jamie Marie	Instructional	2	Elementary K-6 (2810)
5914803	Gravelly, Angelique Iyabo	Educational Specialist	1	Elem. & Secondary School Counselor PK-12 (1839)
2809767	Griffith, Dean A	Instructional	2	General Science 7-12 (8450)
2809767	Griffith, Dean A	Instructional	2	Social Studies 7-12 (8875)
8767092	Gruber, Jenna Bertele	Instructional	1	Art PK-12 (1405)
4540246	Gruszewski, Amanda Marie	Instructional	1	Grades PK-4 (2825)
4540246	Gruszewski, Amanda Marie	Instructional	1	Family-Consumer Sci PK-12 (5600)
4540246	Gruszewski, Amanda Marie	Instructional	1	Special Education PK-8 (9226)
4540246	Gruszewski, Amanda Marie	Instructional	1	Special Education 7-12 (9227)
6934056	Gussow, Steven M	Instructional	2	Mathematics 7-12 (6800)
1563801	Guyer, Melissa Miller	Letter of Equivalency		Master's Equivalency - (1185)
1563801	Guyer, Melissa Miller	Educational Specialist	1	Secondary School Counselor 7-12 (1837)
1563801	Guyer, Melissa Miller	Educational Specialist	2	Secondary School Counselor 7-12 (1837)
1563801	Guyer, Melissa Miller	Instructional	2	Mid-Level English 6-9 (2850)
1563801	Guyer, Melissa Miller	Instructional	2	Social Studies 7-12 (8875)
3567816	Hadley, Lynn	Instructional	2	Bus-Computer-Info Tech PK-12 (1603)
3567816	Hadley, Lynn	Instructional	2	Social Studies 7-12 (8875)
1813936	Hagelgans, Matthew J	Instructional	1	Social Studies 7-12 (8875)
2749242	Hale-Patterson, Melissa P	Endorsement	Endorsement	Instructional Coach PK-12 (1182)
2749242	Hale-Patterson, Melissa P	Instructional	2	Elementary K-6 (2810)

State ID	Employee Name	Certificate Type	Level Code	Certificate Description
2749242	Hale-Patterson, Melissa P	Instructional	2	Special Education PK-12 (9225)
1087343	Hamburger, Karen Marie	Instructional	2	Elementary K-6 (2810)
1087343	Hamburger, Karen Marie	Instructional	2	Mid-Level Mathematics 6-9 (2860)
7090607	Haney-Filippone, Heather Jo	Instructional	1	Elementary K-6 (2810)
7090607	Haney-Filippone, Heather Jo	Instructional	1	Grades PK-4 (2825)
7090607	Haney-Filippone, Heather Jo	Instructional	1	Special Education PK-8 (9226)
4760385	Harbaugh, Amanda Blair	Instructional	2	Elementary K-6 (2810)
4760385	Harbaugh, Amanda Blair	Instructional	2	Mid-Level English 6-9 (2850)
9108013	Hardisky, Jennifer Rebecca	Instructional	1	Biology 7-12 (8405)
2598387	Hardy, Emily Elizabeth	Instructional	1	Grades PK-4 (2825)
2598387	Hardy, Emily Elizabeth	Instructional	1	Special Education PK-8 (9226)
8262939	Harkins, Paul K	Administrative	1	Principal PK-12 (1115)
8262939	Harkins, Paul K	Instructional	2	English 7-12 (3230)
8209824	Harlan, Maria	Instructional	2	Elementary K-6 (2810)
8209824	Harlan, Maria	Instructional	2	Special Education PK-8 (9226)
3408636	Harris, Tracy E	Instructional	2	Elementary K-6 (2810)
3408636	Harris, Tracy E	Instructional	2	Mid-Level Mathematics 6-9 (2860)
3408636	Harris, Tracy E	Instructional	2	Reading Specialist PK-12 (7650)
9387058	Hartlep, Tara R	Instructional	2	Elementary K-6 (2810)
9387058	Hartlep, Tara R	Instructional	2	Mid-Level English 6-9 (2850)
9387058	Hartlep, Tara R	Instructional	2	Mid-Level Mathematics 6-9 (2860)
9387058	Hartlep, Tara R	Program Specialist		English as a Second Language (ESL) PK-12 (4499)
3606539	Hartman, Cathrine S	Instructional	1	Grades PK-4 (2825)
3606539	Hartman, Cathrine S	Instructional	1	Special Education PK-8 (9226)
7359613	Hartman, Robin E	Instructional	2	Elementary K-6 (2810)
8407809	Harvey, Barbara N	Private School - Teacher		Elementary Education K-8 (12810)
8407809	Harvey, Barbara N	Private School - Teacher		Mathematics: Sec. Ed. 9-12 (16800)
8407809	Harvey, Barbara N	Private School - Teacher		Mentally Retarded K-12 (19220)
8407809	Harvey, Barbara N	Private School - Teacher		Physically Handicapped K-12 (19240)
8407809	Harvey, Barbara N	Private School - Teacher		Learning Disabled K-12 (19245)
8407809	Harvey, Barbara N	Private School - Teacher		Soc and Emotionally Dist K-12 (19260)
8407809	Harvey, Barbara N	Instructional	2	Elementary K-6 (2810)
8407809	Harvey, Barbara N	Instructional	2	Mid-Level English 6-9 (2850)
8407809	Harvey, Barbara N	Instructional	2	Mid-Level Mathematics 6-9 (2860)
8407809	Harvey, Barbara N	Instructional	2	Mid-Level Citiz. Ed 6-9 (2870)
8407809	Harvey, Barbara N	Supervisory		Supvr Special Education PK-12 (9215)
8407809	Harvey, Barbara N	Instructional	2	Ment and/or Phys Handicapped K-12 (9235)
7142391	Hathaway, Melanie Lynn	Educational Specialist	1	Inst Technology Specialist PK-12 (1825)

State ID	Employee Name	Certificate Type	Level Code	Certificate Description
7142391	Hathaway, Melanie Lynn	Instructional	2	Elementary K-6 (2810)
7142391	Hathaway, Melanie Lynn	Instructional	2	Early Childhood N-3 (2840)
7142391	Hathaway, Melanie Lynn	Instructional	2	Family-Consumer Sci PK-12 (5600)
7142391	Hathaway, Melanie Lynn	Instructional	2	Special Education PK-8 (9226)
5475409	Hawk, Kristie	Administrative		Principal PK-12 (1115)
5475409	Hawk, Kristie	Instructional	2	Art PK-12 (1405)
1089065	Heard, Pamela Ann	Letter of Equivalency		Master's Equivalency - (1185)
1089065	Heard, Pamela Ann	Instructional	2	Health & Physical Educ PK-12 (4805)
1089065	Heard, Pamela Ann	Instructional	2	Safety Ed/Driver Ed 7-12 (5215)
8167832	Hennig, Ashley Nicole	Instructional	2	Mathematics 7-12 (6800)
1872897	Henretta, Erikka Ann	Instructional	1	Grades PK-4 (2825)
1872897	Henretta, Erikka Ann	Instructional	1	Special Education PK-8 (9226)
7694718	Henriquez, Ibis Raquel	Instructional	1	Spanish PK-12 (4490)
7315086	Heppenstall, Amber Paige	Instructional	1	Grades PK-4 (2825)
7315086	Heppenstall, Amber Paige	Instructional	1	Special Education PK-8 (9226)
2079054	Hetrick, Angela Mae	Instructional	2	Social Studies 7-12 (8875)
9482165	Hewitt, Denna Marcell	Administrative	1	Principal PK-12 (1115)
9482165	Hewitt, Denna Marcell	Instructional	2	English 7-12 (3230)
9482165	Hewitt, Denna Marcell	Instructional	2	Special Education PK-12 (9225)
1463905	Hill, Jessica Ann	Instructional	2	Elementary K-6 (2810)
6586245	Hill, Lisa M	Instructional	2	Elementary K-6 (2810)
6586245	Hill, Lisa M	Instructional	2	Early Childhood N-3 (2840)
6586245	Hill, Lisa M	Instructional	2	Reading Specialist PK-12 (7650)
6208696	Hill, Ocie	Instructional	2	English 7-12 (3230)
6208696	Hill, Ocie	Instructional	2	Social Studies 7-12 (8875)
6208696	Hill, Ocie	Instructional	2	Special Education PK-12 (9225)
5430368	Hilson, Erin R	Administrative	1	Principal PK-12 (1115)
5430368	Hilson, Erin R	Instructional	1	Reading Specialist PK-12 (7650)
5430368	Hilson, Erin R	Instructional	1	Special Education PK-12 (9225)
2026704	Hoff, Rachel Lynn	Instructional	1	Library Science PK-12 (6420)
5893439	Hoffman Long, Melissa R	Instructional	2	Environmental Educ PK-12 (4820)
5893439	Hoffman Long, Melissa R	Instructional	2	Biology 7-12 (8405)
5371396	Hoffman, Kaelyn McKenzie	Instructional	1	Grades PK-4 (2825)
5371396	Hoffman, Kaelyn McKenzie	Instructional	1	Grades 4-8 (All subjects 4-6 ELA & Reading (3100)
5371396	Hoffman, Kaelyn McKenzie	Instructional	1	Special Education PK-8 (9226)
5176786	Hollenbach, Nicolette Marie	Instructional	2	Elementary K-6 (2810)
5176786	Hollenbach, Nicolette Marie	Instructional	2	Special Education PK-12 (9225)
2476895	Holton, Joanna F	Instructional	2	Reading Specialist PK-12 (7650)



State ID	Employee Name	Certificate Type	Level Code	Certificate Description
2476895	Holton, Joanna F	Instructional	2	Special Education PK-12 (9225)
1038684	Hopkins, Ellen P	Instructional	2	Elementary K-6 (2810)
1038684	Hopkins, Ellen P	Instructional	2	Reading Specialist PK-12 (7650)
7461641	Hornbake, Jansen L	Administrative	2	Principal PK-12 (1115)
7461641	Hornbake, Jansen L	Instructional	2	Elementary K-6 (2810)
7461641	Hornbake, Jansen L	Supervisory		Supvr Curriculum & Inst PK-12 (2915)
8945741	Horst, Nicole Elizabeth	Instructional	2	Elementary K-6 (2810)
8945741	Horst, Nicole Elizabeth	Program Specialist		English as a Second Language (ESL) PK-12 (4499)
4049892	Horton, Danielle R	Instructional	2	Bus-Computer-Info Tech PK-12 (1603)
4049892	Horton, Danielle R	Program Specialist		English as a Second Language (ESL) PK-12 (4499)
5474193	Houck, Jessica Marie	Instructional	1	Grades PK-4 (2825)
5964816	Houseknecht, Dayna S	Instructional	2	Elementary K-6 (2810)
5964816	Houseknecht, Dayna S	Instructional	2	Mid-Level English 6-9 (2850)
5964816	Houseknecht, Dayna S	Instructional	2	Mid-Level Citiz. Ed 6-9 (2870)
3105632	Howe, Erin M	Instructional	2	Elementary K-6 (2810)
3105632	Howe, Erin M	Instructional	2	Mid-Level English 6-9 (2850)
3105632	Howe, Erin M	Instructional	2	Mid-Level Mathematics 6-9 (2860)
3274058	Huff, Ashley N	Instructional	2	Elementary K-6 (2810)
7165636	Huffman, Jena Mae	Instructional	2	Elementary K-6 (2810)
7165636	Huffman, Jena Mae	Instructional	2	Mid-Level Mathematics 6-9 (2860)
7165636	Huffman, Jena Mae	Instructional	2	Special Education PK-12 (9225)
3547971	Humanick, Kymberly Diana	Instructional	2	Elementary K-6 (2810)
3547971	Humanick, Kymberly Diana	Program Specialist		English as a Second Language (ESL) PK-12 (4499)
3547971	Humanick, Kymberly Diana	Instructional	2	Special Education PK-12 (9225)
7871924	Hunkele, Terri Lee	Instructional	2	Elementary K-6 (2810)
7871924	Hunkele, Terri Lee	Instructional	2	Special Education PK-12 (9225)
5056734	Hunt, Jocelyn Diane	Instructional	1	Elementary K-6 (2810)
5420463	Iampietro, Jared A	Instructional	2	Biology 7-12 (8405)
1827494	Imbarlina, Cindy	Letter of Equivalency		Master's Equivalency - (1185)
1827494	Imbarlina, Cindy	Instructional	2	Elementary K-6 (2810)
1827494	Imbarlina, Cindy	Instructional	2	Ment and/or Phys Handicapped K-12 (9235)
9456021	Jackson, Erin L	Administrative		Principal PK-12 (1115)
9456021	Jackson, Erin L	Instructional	2	French PK-12 (4410)
6139372	Jackson, Veronica A	Instructional	2	Elementary K-6 (2810)
6139372	Jackson, Veronica A	Instructional	2	Ment and/or Phys Handicapped K-12 (9235)
4791514	Jacob, Linda Michelle	Instructional	1	Elementary K-6 (2810)
7875193	Jafarian, Mia N	Educational Specialist	2	Secondary School Counselor 7-12 (1837)
3584764	Jensen, Richard S	Administrative	2	Principal PK-12 (1115)

State ID	Employee Name	Certificate Type	Level Code	Certificate Description
3584764	Jensen, Richard S	Instructional	2	Social Studies 7-12 (8875)
4834051	Jimenez Brodie, Elinore	Instructional	2	Elementary K-6 (2810)
4834051	Jimenez Brodie, Elinore	Instructional	2	Spanish PK-12 (4490)
9682934	Johnson, Maryann	Administrative	1	Principal PK-12 (1115)
9682934	Johnson, Maryann	Instructional	2	Elementary K-6 (2810)
9682934	Johnson, Maryann	Supervisory		Supvr Special Education PK-12 (9215)
9682934	Johnson, Maryann	Instructional	2	Special Education PK-12 (9225)
1846798	Johnson-Nied, Caitlin	Instructional	2	Elementary K-6 (2810)
1846798	Johnson-Nied, Caitlin	Instructional	2	Early Childhood N-3 (2840)
1846798	Johnson-Nied, Caitlin	Instructional	2	Mid-Level English 6-9 (2850)
1846798	Johnson-Nied, Caitlin	Instructional	2	Mid-Level Mathematics 6-9 (2860)
2586973	Johnston, Jennifer A	Instructional	1	Elementary K-6 (2810)
3575206	Jones, Gabrielle Saracino	Instructional	2	Elementary K-6 (2810)
3575206	Jones, Gabrielle Saracino	Instructional	2	English 7-12 (3230)
3575206	Jones, Gabrielle Saracino	Instructional	2	Special Education PK-12 (9225)
7465124	Joseph, Margret Rene	Instructional	2	Elementary K-6 (2810)
7465124	Joseph, Margret Rene	Instructional	2	English 7-12 (3230)
7465124	Joseph, Margret Rene	Instructional	2	Special Education PK-12 (9225)
3765736	Jusko, Melissa Maria	Instructional	1	Art PK-12 (1405)
2010834	Kammermeier, Amanda	Instructional	1	Early Childhood N-3 (2840)
2010834	Kammermeier, Amanda	Instructional	1	Special Education PK-8 (9226)
2010834	Kammermeier, Amanda	Instructional	1	Special Education Expansion 7-12 (9229)
4156178	Kara, Rebecca J	Instructional	2	Elementary K-6 (2810)
8940986	Karosas, Lisa Marie	Instructional	2	Mid-Level Science 6-9 (2880)
8940986	Karosas, Lisa Marie	Instructional	2	Chemistry 7-12 (8420)
8304964	Karp, Barbara Myers	Instructional	2	Elementary K-6 (2810)
8304964	Karp, Barbara Myers	Instructional	2	Social Studies 7-12 (8875)
7598317	Kaufman, Gillian Spencer	Instructional	2	Grades PK-4 (2825)
7598317	Kaufman, Gillian Spencer	Instructional	2	Special Education PK-8 (9226)
7598317	Kaufman, Gillian Spencer	Instructional	1	Special Education 7-12 (9227)
1052491	Kaufman, Melissa Lynn	Instructional	2	Elementary K-6 (2810)
9625157	Keck, Marianne Christine	Instructional	2	Biology 7-12 (8405)
9625157	Keck, Marianne Christine	Instructional	2	Chemistry 7-12 (8420)
9625157	Keck, Marianne Christine	Instructional	2	Physics 7-12 (8470)
9127352	Keefe, Allison A	Instructional	1	English 7-12 (3230)
7041968	Kelso, Sharon A	Instructional	2	English 7-12 (3230)
8258565	Kennedy, Sabrina C	Instructional	2	Elementary K-6 (2810)
8258565	Kennedy, Sabrina C	Instructional	2	Special Education PK-12 (9225)

State ID	Employee Name	Certificate Type	Level Code	Certificate Description
8947597	Kenzakowski, Rebecca A	Instructional	2	Biology 7-12 (8405)
8947597	Kenzakowski, Rebecca A	Instructional	2	Special Education PK-12 (9225)
9536245	Kerner, Danielle L	Administrative	1	Principal PK-12 (1115)
9536245	Kerner, Danielle L	Private School - Teacher		French K-12 (14410)
9536245	Kerner, Danielle L	Supervisory		Supvr Curriculum & Inst PK-12 (2915)
9536245	Kerner, Danielle L	Instructional	2	English 7-12 (3230)
9536245	Kerner, Danielle L	Instructional	2	French PK-12 (4410)
6463102	Kerns, Lauren Diehl	Educational Specialist	1	Secondary School Counselor 7-12 (1837)
6463102	Kerns, Lauren Diehl	Instructional	2	Mid-Level Mathematics 6-9 (2860)
6463102	Kerns, Lauren Diehl	Instructional	2	Special Education PK-12 (9225)
1349708	Kessler, Julee Megan	Instructional	2	Ment and/or Phys Handicapped K-12 (9235)
7926129	Kiebler, Megan A	Instructional	2	Elementary K-6 (2810)
7926129	Kiebler, Megan A	Instructional	2	Early Childhood N-3 (2840)
8713091	Kieffer, Brittany E	Instructional	2	Elementary K-6 (2810)
8713091	Kieffer, Brittany E	Instructional	2	Special Education PK-12 (9225)
6532305	Kiger, Darian N	Instructional	2	English 7-12 (3230)
2147268	Killam, Caroline Maria	Instructional	1	English 7-12 (3230)
1837828	Kirby, Mary Jean	Instructional	1	Special Education PK-12 (9225)
6725723	Kirchner, Carly Ann	Instructional	2	Elementary K-6 (2810)
6725723	Kirchner, Carly Ann	Instructional	2	Special Education PK-12 (9225)
5436107	Klara, Michelle A	Instructional	2	Mid-Level Mathematics 6-9 (2860)
5436107	Klara, Michelle A	Instructional	2	Mid-Level Science 6-9 (2880)
5436107	Klara, Michelle A	Instructional	2	Environmental Educ PK-12 (4820)
5436107	Klara, Michelle A	Instructional	2	Biology 7-12 (8405)
5436107	Klara, Michelle A	Instructional	2	General Science 7-12 (8450)
5436107	Klara, Michelle A	Instructional	2	Physics 7-12 (8470)
9038906	Klaus, Jane	Educational Specialist	1	Inst Technology Specialist PK-12 (1825)
9038906	Klaus, Jane	Instructional	1	English 7-12 (3230)
9038906	Klaus, Jane	Instructional	1	Social Studies 7-12 (8875)
9014616	Klein, Suzanne Elizabeth	Educational Specialist	2	Elementary School Counselor K-6 (1836)
9014616	Klein, Suzanne Elizabeth	Educational Specialist	2	Secondary School Counselor 7-12 (1837)
9638537	Koch, Allison Rose	Instructional	2	Mid-Level Mathematics 6-9 (2860)
9638537	Koch, Allison Rose	Instructional	2	Family-Consumer Sci PK-12 (5600)
4757876	Kowalok, Krista Marie	Instructional	2	Elementary K-6 (2810)
2986176	Kozak, Tamara Ann	Letter of Equivalency		Master's Equivalency - (1185)
2986176	Kozak, Tamara Ann	Instructional	2	Elementary K-6 (2810)
2986176	Kozak, Tamara Ann	Instructional	2	Ment and/or Phys Handicapped K-12 (9235)
2169428	Kozar, Bridget M	Administrative		Principal PK-12 (1115)

State ID	Employee Name	Certificate Type	Level Code	Certificate Description
2169428	Kozar, Bridget M	Instructional	2	Elementary K-6 (2810)
2451951	Kramer, Marc A	Instructional	2	Health & Physical Educ PK-12 (4805)
2451951	Kramer, Marc A	Instructional	2	Safety Ed/Driver Ed 7-12 (5215)
3965932	Kreseski, Kimberly Ann	Instructional	2	Elementary K-6 (2810)
3965932	Kreseski, Kimberly Ann	Instructional	2	Reading Specialist PK-12 (7650)
1536781	Kreutzer, Candace	Administrative	1	Principal PK-12 (1115)
1536781	Kreutzer, Candace	Instructional	2	Grades PK-4 (2825)
	Krochak, Carla C	Instructional	1	Reading Specialist PK-12 (7650)
8784304	Krol, Nicole S	Instructional	2	Elementary K-6 (2810)
8784304	Krol, Nicole S	Instructional	2	Special Education PK-12 (9225)
1826952	Kroner, Lewis F	Instructional	2	Mid-Level Mathematics 6-9 (2860)
1826952	Kroner, Lewis F	Instructional	2	Mid-Level Science 6-9 (2880)
1826952	Kroner, Lewis F	Instructional	2	Music PK-12 (7205)
7846349	Kubica, Regina Anne	Instructional	2	Mid-Level English 6-9 (2850)
7846349	Kubica, Regina Anne	Instructional	2	Ment and/or Phys Handicapped K-12 (9235)
4972317	Kulp, Justine M	Instructional	2	Elementary K-6 (2810)
4972317	Kulp, Justine M	Instructional	2	Mid-Level English 6-9 (2850)
4972317	Kulp, Justine M	Instructional	2	Mid-Level Mathematics 6-9 (2860)
4972317	Kulp, Justine M	Instructional	2	Mid-Level Citiz. Ed 6-9 (2870)
4972317	Kulp, Justine M	Program Specialist		English as a Second Language (ESL) PK-12 (4499)
9868425	Kunc, Joseph	Instructional	1	Mathematics 7-12 (6800)
4294964	Kunitsky, Diane Marie	Instructional	2	Chemistry 7-12 (8420)
8471928	Kunkel, William D	Educational Specialist	1	Elem. & Secondary School Counselor PK-12 (1839)
8471928	Kunkel, William D	Instructional	1	Social Studies 7-12 (8875)
9246035	Kwiecewski, Dana Susan	Instructional	1	Elementary K-6 (2810)
9246035	Kwiecewski, Dana Susan	Instructional	1	Special Education PK-12 (9225)
5869452	Langer, Shannon E	Instructional	2	Elementary K-6 (2810)
5869452	Langer, Shannon E	Instructional	2	Special Education PK-8 (9226)
3902328	Lanzilotta, Kristen Fay	Instructional	2	Elementary K-6 (2810)
9379892	Lapsker, Kristina	Instructional	2	Grades PK-4 (2825)
9379892	Lapsker, Kristina	Instructional	2	Special Education PK-8 (9226)
7934971	Large, Allison Lee	Instructional	2	Social Studies 7-12 (8875)
7934971	Large, Allison Lee	Instructional	2	Special Education 7-12 (9227)
9175304	Largent, Beth A	Instructional	2	Elementary K-6 (2810)
9175304	Largent, Beth A	Instructional	2	Reading Specialist PK-12 (7650)
9026406	Laser, Mark T	Instructional	2	Bus-Computer-Info Tech PK-12 (1603)
9026406	Laser, Mark T	Instructional	2	Elementary K-6 (2810)
9026406	Laser, Mark T	Instructional	2	Mid-Level Mathematics 6-9 (2860)

State ID	Employee Name	Certificate Type	Level Code	Certificate Description
5936782	Laubach, Elena	Educational Specialist	2	Secondary School Counselor 7-12 (1837)
2707503	Laudenslager, Leslie J	Instructional	2	Elementary K-6 (2810)
2707503	Laudenslager, Leslie J	Instructional	2	English 7-12 (3230)
5765745	Lavacca, Deborah Ann	Instructional	2	Elementary K-6 (2810)
4392169	Lavelle, Patrick Michael	Instructional	2	Special Education PK-12 (9225)
9481531	Learn, Ryan P	Educational Specialist	2	Secondary School Counselor 7-12 (1837)
9481531	Learn, Ryan P	Educational Specialist	2	Elem. & Secondary School Counselor PK-12 (1839)
9635647	Lee, Erica Marie	Educational Specialist	2	Secondary School Counselor 7-12 (1837)
3478745	LeGendre, Annette Marie	Instructional	2	Physics & Mathematics 7-12 (8475)
4956174	Leinweber, Brielle Carol	Instructional	1	Bus-Computer-Info Tech PK-12 (1603)
4956174	Leinweber, Brielle Carol	Instructional	1	Family-Consumer Sci PK-12 (5600)
9089175	Lelko, Susan R	Instructional	2	Bus-Computer-Info Tech PK-12 (1603)
9089175	Lelko, Susan R	Instructional	2	Marketing (Distributive) Ed PK-12 (1666)
9089175	Lelko, Susan R	Instructional	2	Mathematics 7-12 (6800)
9089175	Lelko, Susan R	Instructional	2	Special Education PK-12 (9225)
8480783	Leon, Casidy Alexa	Instructional	1	Grades PK-4 (2825)
8480783	Leon, Casidy Alexa	Instructional	1	Grades 5-6 (2826)
8480783	Leon, Casidy Alexa	Instructional	1	Grades 4-8 (All subjects 4-6 Math 7-8) (3100)
3853409	Leonard, Katie	Instructional	1	English 7-12 (3230)
3853409	Leonard, Katie	Instructional	1	Mathematics 7-12 (6800)
6850415	Lepsch, Anna E	Endorsement	1	Instructional Coach PK-12 (1182)
6850415	Lepsch, Anna E	Instructional	2	Elementary K-6 (2810)
6850415	Lepsch, Anna E	Instructional	2	Mid-Level English 6-9 (2850)
6850415	Lepsch, Anna E	Instructional	2	Mid-Level Citiz. Ed 6-9 (2870)
6850415	Lepsch, Anna E	Instructional	2	Mid-Level Science 6-9 (2880)
6850415	Lepsch, Anna E	Instructional	2	Social Studies 7-12 (8875)
6850415	Lepsch, Anna E	Instructional	2	Special Education PK-12 (9225)
1960576	Lesczynski, Trisa Ann	Instructional	2	Elementary K-6 (2810)
1960576	Lesczynski, Trisa Ann	Instructional	2	Family-Consumer Sci PK-12 (5600)
3183984	Lewis, Jennifer Rebecca	Instructional	2	Elementary K-6 (2810)
3183984	Lewis, Jennifer Rebecca	Instructional	2	Reading Specialist PK-12 (7650)
9045025	Linderman, Jessica L	Instructional	1	Elementary K-6 (2810)
9045025	Linderman, Jessica L	Instructional	1	Special Education PK-12 (9225)
7462653	Lipiec, Susan E	Instructional	1	Elementary K-6 (2810)
7462653	Lipiec, Susan E	Instructional	1	Special Education PK-12 (9225)
2385432	Loccisano, Serena Jo	Administrative	1	Principal PK-12 (1115)
2385432	Loccisano, Serena Jo	Instructional	2	Elementary K-6 (2810)
2385432	Loccisano, Serena Jo	Instructional	2	Special Education PK-12 (9225)

State ID	Employee Name	Certificate Type	Level Code	Certificate Description
8343935	Logan, Laura Jean	Instructional	2	Elementary K-6 (2810)
8343935	Logan, Laura Jean	Instructional	2	English 7-12 (3230)
8343935	Logan, Laura Jean	Instructional	2	Social Studies 7-12 (8875)
9782751	Lomax, Megan	Instructional	1	Grades PK-4 (2825)
5172808	Lombardo, Jaime L	Instructional	1	English 7-12 (3230)
6141696	Long, Crystal Renee	Instructional	2	Mathematics 7-12 (6800)
8125042	Long, Naafeisha Tameka	Instructional	1	Grades PK-4 (2825)
8125042	Long, Naafeisha Tameka	Instructional	1	Special Education PK-8 (9226)
8762691	Lorcheim, Kristine Frances	Instructional	1	Grades PK-4 (2825)
8762691	Lorcheim, Kristine Frances	Instructional	1	Special Education PK-8 (9226)
1097861	Love, Melissa Anne	Instructional	2	Special Education PK-12 (9225)
4237836	Love, Roberta M	Instructional	2	Elementary K-6 (2810)
4237836	Love, Roberta M	Instructional	2	Mid-Level English 6-9 (2850)
5349829	Lubich, Luke A	Instructional	2	Health & Physical Educ PK-12 (4805)
2705827	Lucia, Jennifer A	Instructional	1	English 7-12 (3230)
2705827	Lucia, Jennifer A	Supervisory		Supvr Special Education PK-12 (9215)
2705827	Lucia, Jennifer A	Instructional	1	Special Education PK-12 (9225)
7439432	Luciano, Elizabeth Kathryn	Instructional	1	Elementary K-6 (2810)
7439432	Luciano, Elizabeth Kathryn	Instructional	1	English 7-12 (3230)
5606915	Lucier, Heidi A	Instructional	2	Mid-Level Science 6-9 (2880)
5606915	Lucier, Heidi A	Instructional	2	Biology 7-12 (8405)
2781398	Lutz, Amy Lynn	Instructional	2	Elementary K-6 (2810)
6193169	Lyman, Stephanie M	Instructional	2	Family-Consumer Sci PK-12 (5600)
6193169	Lyman, Stephanie M	Instructional	2	Social Studies 7-12 (8875)
9069282	Lynn, Meghan C	Instructional	2	Bus-Computer-Info Tech PK-12 (1603)
2596726	Lynn, Sharon	Instructional	2	Bus-Computer-Info Tech PK-12 (1603)
2596726	Lynn, Sharon	Instructional	2	Safety Ed/Driver Ed 7-12 (5215)
2596726	Lynn, Sharon	Instructional	2	Mathematics 7-12 (6800)
2596726	Lynn, Sharon	Instructional	2	Special Education PK-12 (9225)
9457194	Mack, Cathryn L	Instructional	2	Ment and/or Phys Handicapped K-12 (9235)
7601878	MacLacklin, Tovah I	Instructional	1	Elementary K-6 (2810)
7601878	MacLacklin, Tovah I	Instructional	1	Early Childhood N-3 (2840)
7601878	MacLacklin, Tovah I	Instructional	1	Mid-Level English 6-9 (2850)
5832314	Macuga, Erica Lynn	Instructional	2	English 7-12 (3230)
6185328	Mahon, Jill	Instructional	2	Elementary K-6 (2810)
8152565	Maines, Beth Ann	Instructional	2	Elementary K-6 (2810)
7621747	Maio, Pamela	Instructional	2	English 7-12 (3230)
1529129	Majzlik, Angela	Instructional	1	Elementary K-6 (2810)

State ID	Employee Name	Certificate Type	Level Code	Certificate Description
1907396	Mallon, Regina Marie	Instructional	2	Elementary K-6 (2810)
1907396	Mallon, Regina Marie	Instructional	2	Mid-Level Citiz. Ed 6-9 (2870)
1907396	Mallon, Regina Marie	Instructional	2	Reading Specialist PK-12 (7650)
1907396	Mallon, Regina Marie	Instructional	2	Special Education PK-12 (9225)
7169438	Malloy, Marianne E	Instructional	2	Elementary K-6 (2810)
7169438	Malloy, Marianne E	Instructional	2	Mid-Level Mathematics 6-9 (2860)
3865127	Mangano, Melissa Marie	Instructional	1	Grades PK-4 (2825)
2918687	Manko, Laura C	Educational Specialist	2	Secondary School Counselor 7-12 (1837)
2918687	Manko, Laura C	Supervisory		Supvr Pupil Personnel Serv PK-12 (2930)
8037641	Mannarino, Stephanie Lynn	Instructional	1	Elementary K-6 (2810)
8037641	Mannarino, Stephanie Lynn	Instructional	1	Special Education PK-8 (9226)
9431073	Marcello, Stefanie Marlene	Instructional	1	Elementary K-6 (2810)
9431073	Marcello, Stefanie Marlene	Instructional	1	Special Education PK-12 (9225)
3930943	Marcinkiewicz, Ilyse Beth	Instructional	1	Mathematics 7-12 (6800)
4149081	Markle, Jennifer Louise	Instructional	1	English 7-12 (3230)
4149081	Markle, Jennifer Louise	Instructional	1	Special Education 7-12 (9227)
5359412	Marquis, Weston J	Instructional	2	Social Studies 7-12 (8875)
1736945	Marshall, Casey Marie	Instructional	2	Elementary K-6 (2810)
3816487	Marsiliano, Judy	Instructional	2	Mathematics 7-12 (6800)
7372015	Martin, Jennifer B	Instructional	1	Spanish PK-12 (4490)
5236512	Martin, Susan Rae	Endorsement		Online Instruction Program PK-12 (1184)
5236512	Martin, Susan Rae	Instructional	1	Social Studies 7-12 (8875)
5236512	Martin, Susan Rae	Instructional	1	Special Education 7-12 (9227)
3521429	Martinez, Barbara Ann	Instructional	1	Reading Specialist PK-12 (7650)
3521429	Martinez, Barbara Ann	Instructional	1	Social Studies 7-12 (8875)
3521429	Martinez, Barbara Ann	Instructional	1	Special Education PK-12 (9225)
1960826	Maruski, Laurie M	Instructional	1	Elementary K-6 (2810)
1960826	Maruski, Laurie M	Instructional	1	Reading Specialist PK-12 (7650)
9157434	Mastropietro, Melissa	Instructional	1	Elementary K-6 (2810)
4108517	Mattis, Sarah Elizabeth	Instructional	1	Grades PK-4 (2825)
4108517	Mattis, Sarah Elizabeth	Instructional	1	Special Education PK-8 (9226)
4136507	McAndrew, Kate Louise	Instructional	2	Earth and Space Science 7-12 (8440)
4136507	McAndrew, Kate Louise	Instructional	2	General Science 7-12 (8450)
1872304	McCabe, Megan Elizabeth	Educational Specialist	2	School Nurse PK-12 (1890)
3850185	McCarthy, James V	Instructional	2	Mid-Level Mathematics 6-9 (2860)
3850185	McCarthy, James V	Instructional	2	Health & Physical Educ PK-12 (4805)
4386179	McCarthy, Valerie Lynn	Instructional	2	Elementary K-6 (2810)
7372496	McCauley, Tamara J	Instructional	1	Elementary K-6 (2810)

State ID	Employee Name	Certificate Type	Level Code	Certificate Description
7372496	McCauley, Tamara J	Instructional	1	Early Childhood N-3 (2840)
5125785	McClain, Melanie Dawn	Instructional	2	Elementary K-6 (2810)
5125785	McClain, Melanie Dawn	Instructional	2	Family-Consumer Sci PK-12 (5600)
2362143	McCleary, Sarah Lorraine	Instructional	1	Elementary K-6 (2810)
4363026	McCormick, Heather M	Administrative	2	Principal PK-12 (1115)
4363026	McCormick, Heather M	Instructional	2	Mid-Level English 6-9 (2850)
4363026	McCormick, Heather M	Supervisory		Supvr Curriculum & Inst PK-12 (2915)
4363026	McCormick, Heather M	Instructional	2	Ment and/or Phys Handicapped K-12 (9235)
5340726	McCracken, Kevin S	Instructional	2	Music PK-12 (7205)
7467268	McCracken, Melissa Kathryn	Instructional	2	Early Childhood N-3 (2840)
7467268	McCracken, Melissa Kathryn	Instructional	2	Hearing Impaired PK-12 (9205)
7467268	McCracken, Melissa Kathryn	Instructional	2	Ment and/or Phys Handicapped K-12 (9235)
5843602	McCrea, Julie Ann	Instructional	1	Biology 7-12 (8405)
5843602	McCrea, Julie Ann	Instructional	1	Earth and Space Science 7-12 (8440)
1983458	McCready, Melissa Sue	Instructional	1	Grades PK-4 (2825)
1983458	McCready, Melissa Sue	Instructional	1	Grades 5-6 (2826)
9503858	McCreary, Adrienne	Instructional	2	Elementary K-6 (2810)
9503858	McCreary, Adrienne	Instructional	2	Early Childhood N-3 (2840)
9503858	McCreary, Adrienne	Instructional	2	Reading Specialist PK-12 (7650)
6052425	McCullough, Kelly S	Instructional	1	Earth and Space Science 7-12 (8440)
6052425	McCullough, Kelly S	Instructional	1	Social Studies 7-12 (8875)
7295194	McDermott, Rachael A	Instructional	2	Elementary K-6 (2810)
7295194	McDermott, Rachael A	Instructional	2	Early Childhood N-3 (2840)
7295194	McDermott, Rachael A	Instructional	2	Special Education PK-12 (9225)
9471057	McEwen, Elizabeth Mary	Endorsement	Endorsement	Instructional Coach PK-12 (1182)
9471057	McEwen, Elizabeth Mary	Instructional	2	Elementary K-6 (2810)
9471057	McEwen, Elizabeth Mary	Instructional	2	Mid-Level English 6-9 (2850)
9471057	McEwen, Elizabeth Mary	Instructional	2	English 7-12 (3230)
9471057	McEwen, Elizabeth Mary	Instructional	2	Reading Specialist PK-12 (7650)
9471057	McEwen, Elizabeth Mary	Instructional	2	Special Education PK-12 (9225)
8757232	McGeehan, Rebecca A	Instructional	HOUSSE Designation	General Science 7-12 (8450)
5473073	McGinty, Jennifer Nicole	Instructional	2	Elementary K-6 (2810)
5473073	McGinty, Jennifer Nicole	Instructional	2	Mid-Level Mathematics 6-9 (2860)
5473073	McGinty, Jennifer Nicole	Instructional	2	Special Education PK-12 (9225)
3621041	McGlothlin, Shelly L	Administrative	1	Principal PK-12 (1115)
3621041	McGlothlin, Shelly L	Supervisory		Supvr Curriculum & Inst PK-12 (2915)
3621041	McGlothlin, Shelly L	Instructional	2	Communications 7-12 (3200)
3621041	McGlothlin, Shelly L	Instructional	2	English 7-12 (3230)



State ID	Employee Name	Certificate Type	Level Code	Certificate Description
7316426	McGlynn, James G	Instructional	2	Mathematics 7-12 (6800)
6514235	McHugh, Kristin Lee	Instructional	2	Art PK-12 (1405)
4819124	McIvor, Ashley N	Educational Specialist	2	School Nurse PK-12 (1890)
7151362	McKeown, Janelle Lee	Instructional	2	English 7-12 (3230)
8037085	McLaughlin, Kimberly Renee	Instructional	2	Elementary K-6 (2810)
8037085	McLaughlin, Kimberly Renee	Instructional	2	Reading Specialist PK-12 (7650)
8037085	McLaughlin, Kimberly Renee	Instructional	2	Special Education PK-12 (9225)
3813852	McMullen, Daniel Christopher	Instructional	1	Mathematics 7-12 (6800)
8536742	McNulty, Corey Thomas	Instructional	2	Social Studies 7-12 (8875)
2089109	McNulty, Michael S	Instructional	2	Mathematics 7-12 (6800)
	McQuaide, David John	Instructional	1	Social Studies 7-12 (8875)
9635814	McQuaide, Theresa J	Instructional	1	Mathematics 7-12 (6800)
5652501	McQuillan, Michael T	Instructional	2	Social Studies 7-12 (8875)
9361723	Mecchia, Jaime Diana	Instructional	2	Elementary K-6 (2810)
9361723	Mecchia, Jaime Diana	Program Specialist		English as a Second Language (ESL) PK-12 (4499)
9361723	Mecchia, Jaime Diana	Instructional	2	Ment and/or Phys Handicapped K-12 (9235)
1659046	Menzler, Sarah Elizabeth	Instructional	2	English 7-12 (3230)
1659046	Menzler, Sarah Elizabeth	Instructional	2	Social Studies 7-12 (8875)
5494746	Mikkelsen, Melissa Marie	Instructional	1	Grades PK-4 (2825)
3078293	Miller, Jeffrey Paul	Administrative	2	Principal PK-12 (1115)
3078293	Miller, Jeffrey Paul	Instructional	2	Environmental Educ PK-12 (4820)
3078293	Miller, Jeffrey Paul	Instructional	2	Biology 7-12 (8405)
3078293	Miller, Jeffrey Paul	Instructional	2	Earth and Space Science 7-12 (8440)
5782691	Miller, Samantha	Instructional	2	English 7-12 (3230)
5782691	Miller, Samantha	Instructional	2	Social Studies 7-12 (8875)
	Mindlin, Elisa L	Instructional	1	Art PK-12 (1405)
9871308	Mirth, Richard Michael	Educational Specialist	2	Secondary School Counselor 7-12 (1837)
9871308	Mirth, Richard Michael	Instructional	2	Mathematics 7-12 (6800)
5493409	Monterroso, Jacqueline Jay	Instructional	2	Elementary K-6 (2810)
5493409	Monterroso, Jacqueline Jay	Instructional	2	Mid-Level Mathematics 6-9 (2860)
5493409	Monterroso, Jacqueline Jay	Instructional	2	Mid-Level Citiz. Ed 6-9 (2870)
4580689	Montgomery, James W	Administrative	2	Principal PK-12 (1115)
4580689	Montgomery, James W	Instructional	2	Social Studies 7-12 (8875)
6383075	Moore, Kristen Lynn	Instructional	2	Grades PK-4 (2825)
6383075	Moore, Kristen Lynn	Instructional	2	Special Education PK-8 (9226)
1270659	Moran, Mary Katherine	Instructional	1	Grades PK-4 (2825)
1270659	Moran, Mary Katherine	Instructional	1	Special Education PK-8 (9226)
2959607	Morantz, Christina Marie	Instructional	1	Elementary K-6 (2810)

State ID	Employee Name	Certificate Type	Level Code	Certificate Description
2959607	Morantz, Christina Marie	Instructional	1	Mid-Level Mathematics 6-9 (2860)
2959607	Morantz, Christina Marie	Instructional	1	Grades 4-8 (All subjects 4-6 ELA & Reading (3100)
2959607	Morantz, Christina Marie	Instructional	1	Grades 4-8 (All subjects 4-6 Science 7-8) (3100)
2959607	Morantz, Christina Marie	Instructional	1	Grades 4-8 (All subjects 4-6, S Stud 7-8) (3100SS)
8593738	Moreno, Catherine	Instructional	2	Elementary K-6 (2810)
8593738	Moreno, Catherine	Instructional	2	Mid-Level English 6-9 (2850)
8593738	Moreno, Catherine	Instructional	2	Mid-Level Citiz. Ed 6-9 (2870)
4101806	Morgan, Taryn D	Instructional	2	Agriculture PK-12 (1200)
3870383	Morian, Diane D	Instructional	2	Elementary K-6 (2810)
3870383	Morian, Diane D	Instructional	2	English 7-12 (3230)
3870383	Morian, Diane D	Instructional	2	Ment and/or Phys Handicapped K-12 (9235)
6326159	Moritz, Kristel D	Educational Specialist	1	School Nurse PK-12 (1890)
3842382	Morlando, Barbara Lynn	Instructional	1	Biology 7-12 (8405)
6460725	Morris, Allyson Elizabeth	Instructional	1	Reading Specialist PK-12 (7650)
6460725	Morris, Allyson Elizabeth	Instructional	1	Special Education PK-8 (9226)
6460725	Morris, Allyson Elizabeth	Instructional	1	Special Education 7-12 (9227)
7276923	Morris, Elizabeth	Instructional	2	Mathematics 7-12 (6800)
5826794	Morrison, Lindsay M	Instructional	2	English 7-12 (3230)
7232784	Morrissey, Laura	Instructional	2	Ment and/or Phys Handicapped K-12 (9235)
5967248	Morrow, Angelina Marie	Instructional	1	Grades PK-4 (2825)
5967248	Morrow, Angelina Marie	Instructional	1	Spanish PK-12 (4490)
3056185	Moyer, Amanda J	Instructional	2	Elementary K-6 (2810)
3056185	Moyer, Amanda J	Instructional	2	English 7-12 (3230)
3056185	Moyer, Amanda J	Instructional	2	Ment and/or Phys Handicapped K-12 (9235)
6786742	Moyer, Jill A	Instructional	1	Elementary K-6 (2810)
6786742	Moyer, Jill A	Instructional	1	Ment and/or Phys Handicapped K-12 (9235)
2856539	Mruskovic, Brenna Colleen	Instructional	1	Social Studies 7-12 (8875)
9427584	Mueller, Antoinette L	Instructional	2	English 7-12 (3230)
9427584	Mueller, Antoinette L	Instructional	2	Reading Specialist PK-12 (7650)
7510523	Mulhollan, Beth Ann	Instructional	2	Elementary K-6 (2810)
7390124	Mulvey, Joanne C	Instructional	2	Mathematics 7-12 (6800)
7390124	Mulvey, Joanne C	Instructional	2	Physics 7-12 (8470)
3820649	Myers, Laci Jo-Lynn	Instructional	1	Elementary K-6 (2810)
3820649	Myers, Laci Jo-Lynn	Instructional	1	Mid-Level Mathematics 6-9 (2860)
6538279	Nagy, Frank Barton	Administrative	2	Principal PK-12 (1115)
6538279	Nagy, Frank Barton	Instructional	2	Mathematics 7-12 (6800)
1786193	Natale, Valerie L	Instructional	2	Elementary K-6 (2810)
1786193	Natale, Valerie L	Supervisory		Supvr Special Education PK-12 (9215)

State ID	Employee Name	Certificate Type	Level Code	Certificate Description
1786193	Natale, Valerie L	Instructional	2	Special Education PK-12 (9225)
5713496	Nawn, Erin Marie	Endorsement		Sci. Tech Engineer & Math (STEM) Ed PK-12 (1181)
5713496	Nawn, Erin Marie	Instructional	2	Elementary K-6 (2810)
5713496	Nawn, Erin Marie	Instructional	2	Mid-Level Mathematics 6-9 (2860)
1981528	Nelson, Eileen C	Educational Specialist	2	Elementary School Counselor K-6 (1836)
2873471	Nicholas, Fallon Nicole	Educational Specialist	2	Elementary School Counselor K-6 (1836)
2873471	Nicholas, Fallon Nicole	Educational Specialist	2	Secondary School Counselor 7-12 (1837)
8186069	Nicholas, Jesse	Instructional	2	English 7-12 (3230)
8186069	Nicholas, Jesse	Instructional	2	Citizenship 7-12 (8825)
8186069	Nicholas, Jesse	Instructional	2	Social Studies 7-12 (8875)
6798439	Nichols, Christina Marie	Instructional	2	Elementary K-6 (2810)
6798439	Nichols, Christina Marie	Instructional	2	Mid-Level Mathematics 6-9 (2860)
6798439	Nichols, Christina Marie	Instructional	2	Mid-Level Science 6-9 (2880)
6798439	Nichols, Christina Marie	Instructional	2	Earth and Space Science 7-12 (8440)
6471651	Nickerson Little, Christy Elizabeth	Instructional	2	Grades PK-4 (2825)
6471651	Nickerson Little, Christy Elizabeth	Instructional	2	Mid-Level Mathematics 6-9 (2860)
6471651	Nickerson Little, Christy Elizabeth	Instructional	2	Reading Specialist PK-12 (7650)
7465013	Nicol, Ericka Samuels	Instructional	2	Biology 7-12 (8405)
7465013	Nicol, Ericka Samuels	Instructional	2	General Science 7-12 (8450)
4085813	Noss, Chelsea Lynne	Instructional	1	Grades PK-4 (2825)
4983716	Noss, Kelly Anne	Educational Specialist	2	Elementary School Counselor K-6 (1836)
4983716	Noss, Kelly Anne	Educational Specialist	2	Secondary School Counselor 7-12 (1837)
6128738	Nugent, Emily Elizabeth	Instructional	2	Earth and Space Science 7-12 (8440)
6128738	Nugent, Emily Elizabeth	Instructional	2	General Science 7-12 (8450)
5398423	Nugent, Stephen R	Instructional	2	Social Studies 7-12 (8875)
5397505	O Donnell, Dana	Instructional	2	Elementary K-6 (2810)
5397505	O Donnell, Dana	Instructional	2	Special Education PK-12 (9225)
3809193	O Donnell, Katie E	Instructional	1	Elementary K-6 (2810)
3809193	O Donnell, Katie E	Instructional	1	Special Education PK-12 (9225)
5474958	O Neill, Carolyn J	Instructional	2	Elementary K-6 (2810)
5474958	O Neill, Carolyn J	Instructional	1	Reading Specialist PK-12 (7650)
5474958	O Neill, Carolyn J	Instructional	2	Special Education PK-12 (9225)
6105673	O Reilly, Jaclyn E	Instructional	2	Elementary K-6 (2810)
6105673	O Reilly, Jaclyn E	Instructional	2	Reading Specialist PK-12 (7650)
8451679	Oakes, Casey Louise	Instructional	1	Elementary K-6 (2810)
6581921	Oberholtzer, Stephanie L	Instructional	2	Elementary K-6 (2810)
8725401	Olbryk, Lacey J	Instructional	2	Grades PK-4 (2825)
8725401	Olbryk, Lacey J	Instructional	2	Special Education PK-8 (9226)

State ID	Employee Name	Certificate Type	Level Code	Certificate Description
6410953	Olsavsky, Michelle Lenore	Endorsement	1	Instructional Coach PK-12 (1182)
6410953	Olsavsky, Michelle Lenore	Instructional	2	Elementary K-6 (2810)
6410953	Olsavsky, Michelle Lenore	Instructional	2	Early Childhood N-3 (2840)
6410953	Olsavsky, Michelle Lenore	Instructional	2	English 7-12 (3230)
6410953	Olsavsky, Michelle Lenore	Instructional	2	Special Education PK-12 (9225)
1312593	Pacheco, Jose Robert	Instructional	2	French PK-12 (4410)
1312593	Pacheco, Jose Robert	Instructional	2	Mathematics 7-12 (6800)
5325374	Pacolay, Dana R	Instructional	2	Health PK-12 (4810)
5325374	Pacolay, Dana R	Instructional	2	Reading Specialist PK-12 (7650)
5325374	Pacolay, Dana R	Instructional	2	Biology 7-12 (8405)
5325374	Pacolay, Dana R	Instructional	2	Special Education PK-12 (9225)
3109573	Pagliei, Lynn Marie	Instructional	2	Elementary K-6 (2810)
3109573	Pagliei, Lynn Marie	Instructional	2	Mid-Level Mathematics 6-9 (2860)
3109573	Pagliei, Lynn Marie	Instructional	2	Special Education PK-12 (9225)
8647848	Palme, Jill Elizabeth	Educational Specialist	2	Secondary School Counselor 7-12 (1837)
8647848	Palme, Jill Elizabeth	Instructional	1	Elementary K-6 (2810)
5735207	Panchura, Chelsey	Instructional	1	English 7-12 (3230)
5735207	Panchura, Chelsey	Instructional	1	Special Education 7-12 (9227)
3172707	Paolino, Kimberly A	Instructional	2	Elementary K-6 (2810)
3172707	Paolino, Kimberly A	Instructional	2	Mid-Level English 6-9 (2850)
3172707	Paolino, Kimberly A	Instructional	2	Mid-Level Mathematics 6-9 (2860)
3172707	Paolino, Kimberly A	Instructional	2	Special Education PK-12 (9225)
4021413	Parkes-Mattox, Gemma M	Instructional	2	English 7-12 (3230)
4021413	Parkes-Mattox, Gemma M	Instructional	2	Special Education PK-12 (9225)
3046982	Pascucci, Jeanne Marie	Instructional	1	Grades PK-4 (2825)
3046982	Pascucci, Jeanne Marie	Instructional	1	English 7-12 (3230)
8905083	Pastin, Laurie Lynn	Letter of Equivalency		Master's Equivalency - (1185)
8905083	Pastin, Laurie Lynn	Instructional	2	Elementary K-6 (2810)
8905083	Pastin, Laurie Lynn	Instructional	2	Grades 4-8 (All subjects 4-6 Math 7-8) (3100)
7906905	Paterson, Judy	Instructional	1	Elementary K-6 (2810)
2429204	Patrick, Agatha A	Instructional	2	Elementary K-6 (2810)
2429204	Patrick, Agatha A	Instructional	2	English 7-12 (3230)
2429204	Patrick, Agatha A	Program Specialist		English as a Second Language (ESL) PK-12 (4499)
2429204	Patrick, Agatha A	Instructional	2	Family-Consumer Sci PK-12 (5600)
2429204	Patrick, Agatha A	Instructional	2	Special Education PK-12 (9225)
2784501	Patterson, Whitney Lynne	Educational Specialist	2	Secondary School Counselor 7-12 (1837)
6501895	Pease, Kelly Ann	Instructional	1	English 7-12 (3230)
1630868	Pelipesky, Michele Anne	Instructional	1	Elementary K-6 (2810)

State ID	Employee Name	Certificate Type	Level Code	Certificate Description
1391528	Pelissier, Michelle	Instructional	2	Elementary K-6 (2810)
1391528	Pelissier, Michelle	Instructional	2	Early Childhood N-3 (2840)
1391528	Pelissier, Michelle	Instructional	2	Special Education PK-12 (9225)
1810325	Perri, Renee C	Instructional	2	Ment and/or Phys Handicapped K-12 (9235)
8529764	Petruzzelli, Dena Marie	Instructional	2	English 7-12 (3230)
8529764	Petruzzelli, Dena Marie	Instructional	2	Library Science PK-12 (6420)
8529764	Petruzzelli, Dena Marie	Instructional	2	Reading Specialist PK-12 (7650)
1764107	Pfeiffer, Eric James	Instructional	2	Elementary K-6 (2810)
1764107	Pfeiffer, Eric James	Instructional	2	Mid-Level Science 6-9 (2880)
1764107	Pfeiffer, Eric James	Instructional	2	Earth and Space Science 7-12 (8440)
3812759	Phillips, Jill Marie	Instructional	2	Elementary K-6 (2810)
3812759	Phillips, Jill Marie	Instructional	2	Social Studies 7-12 (8875)
8023861	Pittman, Sarah B	Instructional	2	Elementary K-6 (2810)
8023861	Pittman, Sarah B	Instructional	2	Special Education PK-12 (9225)
3013026	Platt, Keith A	Instructional	2	Health & Physical Educ PK-12 (4805)
9616535	Pontious, Brianna	Instructional	1	Grades PK-4 (2825)
9616535	Pontious, Brianna	Instructional	1	Special Education PK-8 (9226)
5906173	Porreca, Jessica A	Instructional	1	Elementary K-6 (2810)
9302346	Postler, Suzanne	Instructional	1	Elementary K-6 (2810)
6893542	Pratt, Robert James	Instructional	1	Elementary K-6 (2810)
8174539	Pricer, Danielle Elizabeth	Educational Specialist	2	School Psychologist PK-12 (1875)
5202703	Priest, Candice M	Educational Specialist	1	Secondary School Counselor 7-12 (1837)
4906579	Purdy Hunsberger, Linda	Instructional	2	Bus-Computer-Info Tech PK-12 (1603)
4906579	Purdy Hunsberger, Linda	Instructional	2	Health & Physical Educ PK-12 (4805)
4906579	Purdy Hunsberger, Linda	Instructional	2	Safety Ed/Driver Ed 7-12 (5215)
4906579	Purdy Hunsberger, Linda	Instructional	2	Family-Consumer Sci PK-12 (5600)
8901681	Purdy, Marcy L	Instructional	2	Mathematics 7-12 (6800)
3132359	Puskar, Kathryn P	Instructional	2	Elementary K-6 (2810)
5802785	Pust, Ronda Jean	Instructional	2	Elementary K-6 (2810)
4187263	Pytko, Jonathan Clayton	Instructional	2	Social Studies 7-12 (8875)
2384259	Quackenbush, Kelly J	Instructional	2	Elementary K-6 (2810)
2384259	Quackenbush, Kelly J	Instructional	2	Early Childhood N-3 (2840)
2384259	Quackenbush, Kelly J	Instructional	2	Reading Specialist PK-12 (7650)
2083212	Quisito, Tara Ann	Educational Specialist	2	Secondary School Counselor 7-12 (1837)
5674767	Radico, Lauren N	Instructional	1	Elementary K-6 (2810)
5674767	Radico, Lauren N	Instructional	1	Reading Specialist PK-12 (7650)
5674767	Radico, Lauren N	Instructional	1	Special Education PK-12 (9225)
7628545	Radio, Scott G	Instructional	2	Elementary K-6 (2810)

State ID	Employee Name	Certificate Type	Level Code	Certificate Description
7628545	Radio, Scott G	Instructional	2	Mid-Level Science 6-9 (2880)
3097454	Rakowski, Pamela Denise	Instructional	2	Elementary K-6 (2810)
8190103	Ramsey, Cathryn A	Administrative	1	Principal PK-12 (1115)
8190103	Ramsey, Cathryn A	Instructional	2	Elementary K-6 (2810)
8190103	Ramsey, Cathryn A	Instructional	2	Early Childhood N-3 (2840)
8190103	Ramsey, Cathryn A	Instructional	2	Special Education PK-12 (9225)
1207939	Rau, Sarah Elizabeth	Instructional	2	Biology 7-12 (8405)
4603802	Raught, Amy J	Instructional	2	Elementary K-6 (2810)
4603802	Raught, Amy J	Instructional	2	Technology Education PK-12 (6075)
4603802	Raught, Amy J	Instructional	2	Special Education PK-8 (9226)
4603802	Raught, Amy J	Instructional	2	Special Education Expansion 7-12 (9229)
6798712	Read, Allison Berkowitz	Instructional	2	Elementary K-6 (2810)
6798712	Read, Allison Berkowitz	Instructional	2	English 7-12 (3230)
6798712	Read, Allison Berkowitz	Instructional	2	Family-Consumer Sci PK-12 (5600)
9891649	Reamer, Brittany Nicole	Instructional	1	Grades PK-4 (2825)
9891649	Reamer, Brittany Nicole	Instructional	1	Special Education PK-8 (9226)
5207967	Reese, Jessica Sara	Instructional	2	Elementary K-6 (2810)
5207967	Reese, Jessica Sara	Instructional	2	Mid-Level Mathematics 6-9 (2860)
5207967	Reese, Jessica Sara	Instructional	2	Special Education PK-8 (9226)
5631375	Reiber, Kiersten Leann	Instructional	2	Elementary K-6 (2810)
5631375	Reiber, Kiersten Leann	Instructional	2	Early Childhood N-3 (2840)
5631375	Reiber, Kiersten Leann	Instructional	2	English 7-12 (3230)
6041706	Reimers, Nancy	Instructional	2	Elementary K-6 (2810)
6041706	Reimers, Nancy	Instructional	2	English 7-12 (3230)
6041706	Reimers, Nancy	Instructional	2	Reading Specialist PK-12 (7650)
6041706	Reimers, Nancy	Instructional	2	Ment and/or Phys Handicapped K-12 (9235)
7047017	Reis, Derick J	Instructional	1	Elementary K-6 (2810)
6247232	Renner, Katherine	Instructional	1	Reading Specialist PK-12 (7650)
4740526	Rex, Shelley R	Instructional	1	Bus-Computer-Info Tech PK-12 (1603)
5303639	Richards-Walter, Marisa Grace	Instructional	1	Elementary K-6 (2810)
5303639	Richards-Walter, Marisa Grace	Instructional	1	Mid-Level Mathematics 6-9 (2860)
6953949	Richardson, Colleen Shannon	Administrative	1	Principal PK-12 (1115)
6953949	Richardson, Colleen Shannon	Instructional	2	Elementary K-6 (2810)
6953949	Richardson, Colleen Shannon	Instructional	2	Mid-Level English 6-9 (2850)
6232586	Riexinger, Anna Elizabeth	Instructional	1	Grades 4-8 (All subjects 4-6 Science 7-8) (3100)
6232586	Riexinger, Anna Elizabeth	Instructional	1	Family-Consumer Sci PK-12 (5600)
6232586	Riexinger, Anna Elizabeth	Instructional	1	Biology 7-12 (8405)
9076017	Riggle, Carmen Paige	Instructional	1	Grades PK-4 (2825)

State ID	Employee Name	Certificate Type	Level Code	Certificate Description
9076017	Riggle, Carmen Paige	Instructional	1	Special Education PK-8 (9226)
4810264	Riggs, John	Instructional	2	English 7-12 (3230)
4103425	Rinaldi, Andrew J	Instructional	2	Music PK-12 (7205)
1576568	Rizzo, Felicia L	Instructional	1	Elementary K-6 (2810)
7825478	Robbins, Corina Marie	Instructional	1	Health & Physical Educ PK-12 (4805)
1716534	Robosky, Jalina A	Instructional	1	Bus-Computer-Info Tech PK-12 (1603)
1716534	Robosky, Jalina A	Instructional	1	Elementary K-6 (2810)
3127261	Rockower, Mindy Sharon	Educational Specialist	2	Elementary School Counselor K-6 (1836)
3127261	Rockower, Mindy Sharon	Educational Specialist	2	Secondary School Counselor 7-12 (1837)
3791683	Rodriguez, Gina	Instructional	1	Grades PK-4 (2825)
3791683	Rodriguez, Gina	Instructional	1	Special Education PK-8 (9226)
4210894	Rodzwic, Tara Lynn	Instructional	2	Elementary K-6 (2810)
4210894	Rodzwic, Tara Lynn	Instructional	2	Special Education PK-12 (9225)
1092723	Ronosky, Sarah Marie	Instructional	2	Elementary K-6 (2810)
1092723	Ronosky, Sarah Marie	Instructional	2	Mid-Level Mathematics 6-9 (2860)
1092723	Ronosky, Sarah Marie	Supervisory		Supvr Special Education PK-12 (9215)
1092723	Ronosky, Sarah Marie	Instructional	2	Special Education PK-12 (9225)
4651015	Rosenbaum, Aliyah Marie	Instructional	1	Grades PK-4 (2825)
7276961	Rosenberger, Shauna	Instructional	2	Elementary K-6 (2810)
1464047	Ruffner, Zoleanne S	Instructional	1	English 7-12 (3230)
1464047	Ruffner, Zoleanne S	Instructional	1	Social Studies 7-12 (8875)
2153019	Ryan, Elizabeth B	Endorsement		Online Instruction Program PK-12 (1184)
2153019	Ryan, Elizabeth B	Instructional	2	Mathematics 7-12 (6800)
6950107	Ryen, Brianne B	Instructional	1	Biology 7-12 (8405)
6946217	Saad, Tammy L	Instructional	2	Elementary K-6 (2810)
6946217	Saad, Tammy L	Instructional	2	Early Childhood N-3 (2840)
1652126	Salimbene, Ashley Marie	Instructional	2	Social Studies 7-12 (8875)
1652126	Salimbene, Ashley Marie	Instructional	2	Special Education 7-12 (9227)
7521308	Salony, Lisa	Instructional	1	Elementary K-6 (2810)
1934283	Samar, Lisa Steppe	Instructional	2	Elementary K-6 (2810)
1934283	Samar, Lisa Steppe	Instructional	2	Early Childhood N-3 (2840)
1934283	Samar, Lisa Steppe	Instructional	2	Family-Consumer Sci PK-12 (5600)
1934283	Samar, Lisa Steppe	Instructional	2	Reading Specialist PK-12 (7650)
4957692	Sams, Rachel	Instructional	2	Elementary K-6 (2810)
3623261	Sanders, Stefanie J	Instructional	1	Grades PK-4 (2825)
3623261	Sanders, Stefanie J	Instructional	1	Grades 5-6 (2826)
8125834	Sarber, Carl William	Instructional	1	Elementary K-6 (2810)
8125834	Sarber, Carl William	Instructional	1	Mid-Level English 6-9 (2850)

State ID	Employee Name	Certificate Type	Level Code	Certificate Description
8125834	Sarber, Carl William	Instructional	1	Mid-Level Mathematics 6-9 (2860)
7014575	Sarber, Kenneth Ogden	Instructional	2	Elementary K-6 (2810)
7014575	Sarber, Kenneth Ogden	Instructional	2	Mid-Level Mathematics 6-9 (2860)
3562787	Sattler, Emily R	Educational Specialist	1	Inst Technology Specialist PK-12 (1825)
3562787	Sattler, Emily R	Instructional	2	Elementary K-6 (2810)
3562787	Sattler, Emily R	Instructional	2	Mid-Level English 6-9 (2850)
3562787	Sattler, Emily R	Instructional	2	Mid-Level Mathematics 6-9 (2860)
3562787	Sattler, Emily R	Instructional	2	Mid-Level Citiz. Ed 6-9 (2870)
3562787	Sattler, Emily R	Instructional	2	Mid-Level Science 6-9 (2880)
3562787	Sattler, Emily R	Instructional	2	Reading Specialist PK-12 (7650)
6402734	Savitz, Lisa K	Instructional	2	Biology 7-12 (8405)
6402734	Savitz, Lisa K	Instructional	2	Chemistry 7-12 (8420)
6402734	Savitz, Lisa K	Instructional	2	Special Education PK-12 (9225)
2918713	Scears, Breanne M	Instructional	2	Elementary K-6 (2810)
2918713	Scears, Breanne M	Instructional	2	Mid-Level English 6-9 (2850)
2918713	Scears, Breanne M	Instructional	2	Reading Specialist PK-12 (7650)
2918713	Scears, Breanne M	Instructional	2	Special Education PK-12 (9225)
6297524	Schall, Danielle Marie	Instructional	2	Elementary K-6 (2810)
6297524	Schall, Danielle Marie	Supervisory		Supvr Special Education PK-12 (9215)
6297524	Schall, Danielle Marie	Instructional	2	Special Education PK-12 (9225)
1291348	Schar, Jill C	Instructional	1	Elementary K-6 (2810)
5365472	Scheib, Alyson Jaye	Instructional	1	General Science 7-12 (8450)
1738672	Scheirer, Michael J	Endorsement	Endorsement	Instructional Coach PK-12 (1182)
1738672	Scheirer, Michael J	Instructional	2	English 7-12 (3230)
1738672	Scheirer, Michael J	Instructional	2	Citizenship 7-12 (8825)
1738672	Scheirer, Michael J	Instructional	2	Social Studies 7-12 (8875)
4162507	Scherrbaum, Jaclyn Joyce	Instructional	2	Social Studies 7-12 (8875)
6546756	Schmidt, Ashley Brooke	Instructional	2	Elementary K-6 (2810)
6546756	Schmidt, Ashley Brooke	Instructional	2	Special Education PK-12 (9225)
1754502	Schreiner, Jenna M	Endorsement	Endorsement	Gifted PK-12 (1189)
1754502	Schreiner, Jenna M	Instructional	2	Elementary K-6 (2810)
1754502	Schreiner, Jenna M	Instructional	2	Reading Specialist PK-12 (7650)
1754502	Schreiner, Jenna M	Instructional	2	Special Education PK-12 (9225)
9038206	Schwartz, Olivia Marie	Private School - Asst or Teacher		Nursery/Kindergarten N-K (12833)
9038206	Schwartz, Olivia Marie	Instructional	2	Elementary K-6 (2810)
2496286	Schweizer, Cara Marie	Instructional	2	Environmental Educ PK-12 (4820)
2496286	Schweizer, Cara Marie	Instructional	2	Earth and Space Science 7-12 (8440)
2496286	Schweizer, Cara Marie	Instructional	2	General Science 7-12 (8450)



State ID	Employee Name	Certificate Type	Level Code	Certificate Description
3057497	Scotillo-Sowa, Christina M	Instructional	1	Elementary K-6 (2810)
3057497	Scotillo-Sowa, Christina M	Instructional	1	Special Education PK-12 (9225)
1324972	Scott, Heather Lee	Instructional	1	Health & Physical Educ PK-12 (4805)
8263036	Scrip, Erin Marie	Private School - Teacher		Mentally Retarded K-12 (19220)
8263036	Scrip, Erin Marie	Private School - Teacher		Soc and Emotionally Dist K-12 (19260)
8263036	Scrip, Erin Marie	Instructional	2	Elementary K-6 (2810)
8263036	Scrip, Erin Marie	Instructional	2	Special Education PK-12 (9225)
	Sears, Mara Boto	Instructional	1	Mathematics 7-12 (6800)
7012802	Seraut Schlager, Lauren Jannine	Instructional	1	Health & Physical Educ PK-12 (4805)
7012802	Seraut Schlager, Lauren Jannine	Instructional	1	Health PK-12 (4810)
1205208	Severino, Jill	Instructional	2	Elementary K-6 (2810)
1205208	Severino, Jill	Instructional	2	English 7-12 (3230)
1205208	Severino, Jill	Instructional	2	Special Education PK-12 (9225)
1219598	Shaffer, Bethann	Instructional	2	Elementary K-6 (2810)
1219598	Shaffer, Bethann	Program Specialist		English as a Second Language (ESL) PK-12 (4499)
1219598	Shaffer, Bethann	Instructional	2	Social Studies 7-12 (8875)
1219598	Shaffer, Bethann	Instructional	2	Ment and/or Phys Handicapped K-12 (9235)
7290536	Shaffer, Jamie D	Instructional	2	Elementary K-6 (2810)
1783096	Shaffer, Janelle R	Instructional	2	Elementary K-6 (2810)
1783096	Shaffer, Janelle R	Instructional	2	Special Education PK-12 (9225)
1504512	Shaffer, Lauren Elizabeth	Instructional	2	Social Studies 7-12 (8875)
7572705	Shaltes, Alison Mislanovich	Instructional	2	Elementary K-6 (2810)
7572705	Shaltes, Alison Mislanovich	Instructional	2	Mid-Level English 6-9 (2850)
7572705	Shaltes, Alison Mislanovich	Instructional	2	Reading Specialist PK-12 (7650)
5341385	Shannon, Keri Beth	Instructional	2	Elementary K-6 (2810)
5341385	Shannon, Keri Beth	Instructional	HOUSSE Designation	Mid-Level English 6-9 (2850)
5341385	Shannon, Keri Beth	Instructional	HOUSSE Designation	Mid-Level Mathematics 6-9 (2860)
5341385	Shannon, Keri Beth	Instructional	2	English 7-12 (3230)
5341385	Shannon, Keri Beth	Instructional	2	Special Education PK-12 (9225)
1741679	Shea, Amy M	Educational Specialist	2	Secondary School Counselor 7-12 (1837)
5167965	Shebeck, Regan Lynne	Administrative	2	Principal PK-12 (1115)
5167965	Shebeck, Regan Lynne	Instructional	2	Biology 7-12 (8405)
5167965	Shebeck, Regan Lynne	Instructional	2	General Science 7-12 (8450)
4157347	Sheffo, Arlene	Instructional	2	Elementary K-6 (2810)
4157347	Sheffo, Arlene	Instructional	2	Mid-Level Mathematics 6-9 (2860)
4157347	Sheffo, Arlene	Instructional	2	Reading Specialist PK-12 (7650)
7020427	Shehan, Amy M	Educational Specialist	1	Elem. & Secondary School Counselor PK-12 (1839)
2016952	Shepard, Selina M	Instructional	2	Biology 7-12 (8405)

State ID	Employee Name	Certificate Type	Level Code	Certificate Description
9217323	Shields, Thomas Richard	Instructional	2	Latin PK-12 (4030)
9217323	Shields, Thomas Richard	Instructional	2	Social Studies 7-12 (8875)
7304928	Shiff, Natalie Lowe	Instructional	1	Elementary K-6 (2810)
2391473	Shivetts, Stephanie Lynn	Educational Specialist	2	Elementary School Counselor K-6 (1836)
2391473	Shivetts, Stephanie Lynn	Educational Specialist	2	Secondary School Counselor 7-12 (1837)
5458473	Shonberg, Cynthia Lee	Instructional	2	Biology 7-12 (8405)
5458473	Shonberg, Cynthia Lee	Instructional	2	Chemistry 7-12 (8420)
7028645	Shoop, Elizabeth Ann	Instructional	1	Elementary K-6 (2810)
7028645	Shoop, Elizabeth Ann	Instructional	1	Grades 4-8 (All subjects 4-6 Science 7-8) (3100)
7028645	Shoop, Elizabeth Ann	Instructional	1	Grades 4-8 (All subjects 4-6 Science 7-8) (3100)
7028645	Shoop, Elizabeth Ann	Instructional	1	Special Education PK-12 (9225)
8646283	Short, Jonna Rose	Instructional	1	Grades PK-4 (2825)
8646283	Short, Jonna Rose	Program Specialist		English as a Second Language (ESL) PK-12 (4499)
9252603	Shuttleworth, Stephen A	Instructional	2	Mid-Level Mathematics 6-9 (2860)
9252603	Shuttleworth, Stephen A	Instructional	2	Social Studies 7-12 (8875)
9863512	Silberman, Heather S	Instructional	2	English 7-12 (3230)
9863512	Silberman, Heather S	Instructional	2	Ment and/or Phys Handicapped K-12 (9235)
3415419	Simpson, Nichole Louise	Instructional	2	Art PK-12 (1405)
8349429	Sinan, Megan C	Instructional	1	English 7-12 (3230)
8349429	Sinan, Megan C	Instructional	1	Family-Consumer Sci PK-12 (5600)
8349429	Sinan, Megan C	Instructional	1	Mathematics 7-12 (6800)
9674013	Skelly, Courtney Marie	Instructional	2	Grades PK-4 (2825)
9674013	Skelly, Courtney Marie	Program Specialist		English as a Second Language (ESL) PK-12 (4499)
9674013	Skelly, Courtney Marie	Instructional	2	Special Education PK-12 (9225)
2692105	Slacktish, Erinn Keelie	Instructional	HOUSSE Designation	English 7-12 (3230)
2692105	Slacktish, Erinn Keelie	Instructional	HOUSSE Designation	Mathematics 7-12 (6800)
2692105	Slacktish, Erinn Keelie	Instructional	HOUSSE Designation	Social Studies 7-12 (8875)
2692105	Slacktish, Erinn Keelie	Supervisory		Supvr Special Education PK-12 (9215)
2692105	Slacktish, Erinn Keelie	Instructional	2	Special Education PK-12 (9225)
3835272	Smith, Ashley R	Instructional	2	Elementary K-6 (2810)
7083191	Smith, Joseph Bart	Instructional	2	Mid-Level Science 6-9 (2880)
7083191	Smith, Joseph Bart	Instructional	2	Biology 7-12 (8405)
7083191	Smith, Joseph Bart	Instructional	2	General Science 7-12 (8450)
5430595	Smith, Laurie B	Clearance		FBI Clearance
5430595	Smith, Laurie B	Clearance		PA Child Abuse Clearance
2375103	Smith, Patricia Marie	Instructional	2	Mathematics 7-12 (6800)
2383109	Smith, Tonya L	Endorsement	Endorsement	Instructional Coach PK-12 (1182)
2383109	Smith, Tonya L	Instructional	2	English 7-12 (3230)

State ID	Employee Name	Certificate Type	Level Code	Certificate Description
3045108	Smyntek, Michael A	Instructional	2	Social Studies 7-12 (8875)
6863973	Snyder, Kelly Leigh	Instructional	2	Elementary K-6 (2810)
6863973	Snyder, Kelly Leigh	Instructional	2	Early Childhood N-3 (2840)
6863973	Snyder, Kelly Leigh	Instructional	2	Reading Specialist PK-12 (7650)
9397186	Soda, Lory A	Instructional	2	Health & Physical Educ PK-12 (4805)
3971083	Sonlin, Allison Mott	Instructional	2	Communications 7-12 (3200)
3971083	Sonlin, Allison Mott	Instructional	2	English 7-12 (3230)
4517079	Spess, Chantel A	Instructional	2	Social Studies 7-12 (8875)
4320476	Spindler, Amber L	Instructional	2	Elementary K-6 (2810)
4320476	Spindler, Amber L	Instructional	2	Reading Specialist PK-12 (7650)
4320476	Spindler, Amber L	Instructional	2	Special Education PK-12 (9225)
2579716	Spratt, Leslie D	Educational Specialist	1	Elem. & Secondary School Counselor PK-12 (1839)
2579716	Spratt, Leslie D	Instructional	2	Ment and/or Phys Handicapped K-12 (9235)
9214593	Staab, Michelle L	Instructional	2	Elementary K-6 (2810)
7238027	Stabilito, Catherine M	Instructional	2	Library Science PK-12 (6420)
7238027	Stabilito, Catherine M	Instructional	2	Social Studies 7-12 (8875)
8269473	Stalebrink, Meghan D	Instructional	2	English 7-12 (3230)
2865256	Staley, Amber	Instructional	2	Elementary K-6 (2810)
2865256	Staley, Amber	Instructional	2	Special Education PK-12 (9225)
1658035	Staley, Ashly D	Instructional	2	English 7-12 (3230)
1658035	Staley, Ashly D	Instructional	2	Mathematics 7-12 (6800)
1534506	Stanforth, Melanie	Instructional	1	Speech & Language Impaired PK-12 (9265)
5026504	Stapf, Laura L	Instructional	2	Elementary K-6 (2810)
5026504	Stapf, Laura L	Instructional	2	Special Education PK-12 (9225)
3815368	Stecker, Pamela	Endorsement		Gifted PK-12 (1189)
3815368	Stecker, Pamela	Instructional	2	English 7-12 (3230)
9858356	Steinberg, Natalie Blair	Instructional	1	Elementary K-6 (2810)
6309037	Stenson, Lauren	Educational Specialist	2	Elem. & Secondary School Counselor PK-12 (1839)
2937845	Stephenson, Tiana Noelle	Instructional	1	English 7-12 (3230)
2937845	Stephenson, Tiana Noelle	Instructional	1	Special Education 7-12 (9227)
5650892	Stevens, Beth Ann	Instructional	2	Elementary K-6 (2810)
5835909	Stevens, Brett Elizabeth	Instructional	1	Grades PK-4 (2825)
5835909	Stevens, Brett Elizabeth	Instructional	1	Grades 5-6 (2826)
5835909	Stevens, Brett Elizabeth	Instructional	1	English 7-12 (3230)
5835909	Stevens, Brett Elizabeth	Instructional	1	Social Studies 7-12 (8875)
5835909	Stevens, Brett Elizabeth	Instructional	1	Special Education PK-8 (9226)
5835909	Stevens, Brett Elizabeth	Instructional	1	Special Education Expansion 7-12 (9229)
9801486	Stiles, Heather	Instructional	2	Biology 7-12 (8405)

State ID	Employee Name	Certificate Type	Level Code	Certificate Description
3639419	Stone, Leah M	Instructional	2	Family-Consumer Sci PK-12 (5600)
3639419	Stone, Leah M	Instructional	2	Mathematics 7-12 (6800)
4316015	Strong, Kimberly	Instructional	2	Elementary K-6 (2810)
8359342	Stump, Melissa C	Instructional	2	Art PK-12 (1405)
8359342	Stump, Melissa C	Instructional	2	English 7-12 (3230)
8359342	Stump, Melissa C	Instructional	2	Special Education PK-12 (9225)
7576194	Stump, Shelley A	Instructional	2	Elementary K-6 (2810)
7576194	Stump, Shelley A	Instructional	2	Mid-Level English 6-9 (2850)
7576194	Stump, Shelley A	Instructional	2	Mid-Level Mathematics 6-9 (2860)
7576194	Stump, Shelley A	Instructional	2	Mid-Level Citiz. Ed 6-9 (2870)
7576194	Stump, Shelley A	Instructional	2	Mid-Level Science 6-9 (2880)
7576194	Stump, Shelley A	Instructional	2	Health & Physical Educ PK-12 (4805)
7576194	Stump, Shelley A	Instructional	2	Special Education PK-12 (9225)
3608741	Sukanick, Peter D	Instructional	2	Health & Physical Educ PK-12 (4805)
8068396	Super, Laurie Gail	Endorsement		Instructional Coach PK-12 (1182)
8068396	Super, Laurie Gail	Instructional	2	Elementary K-6 (2810)
8068396	Super, Laurie Gail	Instructional	2	Special Education PK-12 (9225)
6873915	Svonavec, Lauren J	Instructional	2	Grades PK-4 (2825)
6873915	Svonavec, Lauren J	Instructional	2	Reading Specialist PK-12 (7650)
6873915	Svonavec, Lauren J	Instructional	2	Special Education PK-8 (9226)
6797603	Sweeney, Allison	Instructional	2	Elementary K-6 (2810)
6797603	Sweeney, Allison	Instructional	2	Special Education PK-12 (9225)
2109704	Swick, Brittney Jean	Instructional	2	Elementary K-6 (2810)
2109704	Swick, Brittney Jean	Instructional	2	Special Education PK-12 (9225)
1704203	Taggart, Andrea	Instructional	2	Elementary K-6 (2810)
1704203	Taggart, Andrea	Instructional	2	Reading Specialist PK-12 (7650)
1305876	Tainter, Erin F	Instructional	2	Mid-Level Science 6-9 (2880)
1305876	Tainter, Erin F	Instructional	2	Biology 7-12 (8405)
1305876	Tainter, Erin F	Instructional	2	Chemistry 7-12 (8420)
6925283	Tapera, Dana	Instructional	1	Mathematics 7-12 (6800)
7820563	Taylor, Laura Ellen	Instructional	1	Elementary K-6 (2810)
8157431	Thayer, Barbara Jean	Instructional	2	Elementary K-6 (2810)
8157431	Thayer, Barbara Jean	Instructional	2	Early Childhood N-3 (2840)
8157431	Thayer, Barbara Jean	Instructional	2	English 7-12 (3230)
8157431	Thayer, Barbara Jean	Instructional	2	Reading Specialist PK-12 (7650)
1601727	Thomas, Amber Marie	Instructional	1	Grades PK-4 (2825)
1601727	Thomas, Amber Marie	Instructional	1	Special Education PK-8 (9226)
9515616	Thomas, Christine Wiles	Instructional	2	Elementary K-6 (2810)

State ID	Employee Name	Certificate Type	Level Code	Certificate Description
9515616	Thomas, Christine Wiles	Instructional	2	Mid-Level English 6-9 (2850)
9515616	Thomas, Christine Wiles	Instructional	2	Mid-Level Mathematics 6-9 (2860)
9515616	Thomas, Christine Wiles	Instructional	2	Special Education PK-12 (9225)
9747167	Thomas, Jennine Michelle	Instructional	2	Social Studies 7-12 (8875)
9564086	Thomas, John C	Endorsement	Endorsement	Instructional Coach PK-12 (1182)
9564086	Thomas, John C	Instructional	2	Citizenship 7-12 (8825)
8617958	Thomas, Robert John	Instructional	1	Art PK-12 (1405)
5415083	Thompson, Jennifer M	Private School - Asst or Teacher		Nursery/Kindergarten N-K (12833)
5415083	Thompson, Jennifer M	Instructional	2	Elementary K-6 (2810)
3189451	Tilsner, Michelle	Instructional	2	English 7-12 (3230)
3189451	Tilsner, Michelle	Instructional	2	Reading Specialist PK-12 (7650)
3189451	Tilsner, Michelle	Instructional	2	Social Studies 7-12 (8875)
6732795	Titus, Lorna Francesca	Instructional	1	Elementary K-6 (2810)
6732795	Titus, Lorna Francesca	Instructional	1	Special Education PK-12 (9225)
6375062	Tkach, Amber L	Instructional	2	English 7-12 (3230)
6045927	Tomik, Amanda	Instructional	1	Grades PK-4 (2825)
6045927	Tomik, Amanda	Instructional	1	Grades 5-6 (2826)
4108214	Trott, Alyssa Marie	Instructional	1	Elementary K-6 (2810)
4108214	Trott, Alyssa Marie	Instructional	1	Special Education PK-8 (9226)
4108214	Trott, Alyssa Marie	Instructional	1	Special Education Expansion 7-12 (9229)
9463507	Tumas, John P	Instructional	2	Bus-Computer-Info Tech PK-12 (1603)
9463507	Tumas, John P	Instructional	2	Library Science PK-12 (6420)
9463507	Tumas, John P	Instructional	2	Social Studies 7-12 (8875)
3526216	Tybl, Mary Susan	Instructional	2	Mathematics 7-12 (6800)
6535281	Tymeson, Leah A	Instructional	1	Earth and Space Science 7-12 (8440)
1953249	Ulewicz, Janet Marie	Instructional	2	Elementary K-6 (2810)
1953249	Ulewicz, Janet Marie	Instructional	2	Special Education PK-8 (9226)
5051796	Vasil, Jay J	Administrative	1	Principal PK-12 (1115)
5051796	Vasil, Jay J	Administrative		Vocational Admin Dir. 7-12 (2300)
5051796	Vasil, Jay J	Instructional	2	Mid-Level English 6-9 (2850)
5051796	Vasil, Jay J	Instructional	2	Mid-Level Citiz. Ed 6-9 (2870)
5051796	Vasil, Jay J	Instructional	2	Health & Physical Educ PK-12 (4805)
5051796	Vasil, Jay J	Instructional	2	Safety Ed/Driver Ed 7-12 (5215)
5051796	Vasil, Jay J	Instructional	2	Family-Consumer Sci PK-12 (5600)
2784396	Velto, Rachel Andrea	Instructional	2	English 7-12 (3230)
2784396	Velto, Rachel Andrea	Instructional	2	Spanish PK-12 (4490)
1429502	Verbecken, Michelle Lee	Private School - Asst or Teacher		Nursery/Kindergarten N-K (12833)
1429502	Verbecken, Michelle Lee	Instructional	2	Elementary K-6 (2810)

State ID	Employee Name	Certificate Type	Level Code	Certificate Description
5735753	Vietmeier, Stacy L	Instructional	2	Elementary K-6 (2810)
5735753	Vietmeier, Stacy L	Instructional	HOUSSE Designation	English 7-12 (3230)
5735753	Vietmeier, Stacy L	Instructional	HOUSSE Designation	General Science 7-12 (8450)
5735753	Vietmeier, Stacy L	Instructional	HOUSSE Designation	Social Studies 7-12 (8875)
5735753	Vietmeier, Stacy L	Instructional	2	Special Education PK-12 (9225)
1821694	Volpe, Vallorrie Fitzgerald	Instructional	2	Elementary K-6 (2810)
1821694	Volpe, Vallorrie Fitzgerald	Instructional	2	Mid-Level Mathematics 6-9 (2860)
1821694	Volpe, Vallorrie Fitzgerald	Instructional	2	Mid-Level Science 6-9 (2880)
2742075	Vuong Schmick, Thy Minh	Instructional	2	Mid-Level Science 6-9 (2880)
2742075	Vuong Schmick, Thy Minh	Instructional	2	Chemistry 7-12 (8420)
9241316	Wagner, Alexis Carolina	Instructional	1	Social Studies 7-12 (8875)
9241316	Wagner, Alexis Carolina	Instructional	1	Special Education 7-12 (9227)
1657956	Walczak, Brittney Ann	Instructional	1	Grades PK-4 (2825)
1657956	Walczak, Brittney Ann	Instructional	1	Special Education PK-8 (9226)
2382481	Walker, Tara M	Instructional	1	Special Education PK-12 (9225)
7358162	Walsh, Mary Elise	Letter of Equivalency		Master's Equivalency - (1185)
7358162	Walsh, Mary Elise	Instructional	2	Elementary K-6 (2810)
7358162	Walsh, Mary Elise	Instructional	2	Mid-Level English 6-9 (2850)
7358162	Walsh, Mary Elise	Instructional	2	Mid-Level Mathematics 6-9 (2860)
7358162	Walsh, Mary Elise	Program Specialist		English as a Second Language (ESL) PK-12 (4499)
9097202	Walters, Carrie Irene	Instructional	1	Elementary K-6 (2810)
1978748	Walters, Melanie A	Instructional	2	Mid-Level Science 6-9 (2880)
1978748	Walters, Melanie A	Instructional	2	Reading Specialist PK-12 (7650)
1978748	Walters, Melanie A	Instructional	2	Biology 7-12 (8405)
5276125	Waters, Nancy Miriam	Instructional	2	Bus-Computer-Info Tech PK-12 (1603)
5276125	Waters, Nancy Miriam	Instructional	2	Marketing 7-12 (1640)
5276125	Waters, Nancy Miriam	Instructional	2	Office Technologies 7-12 (1658)
5276125	Waters, Nancy Miriam	Program Specialist		English as a Second Language (ESL) PK-12 (4499)
2562529	Watts, Brigitt	Instructional	2	Art PK-12 (1405)
2562529	Watts, Brigitt	Instructional	2	Bus-Computer-Info Tech PK-12 (1603)
2156432	Webb, Alexandra L	Instructional	2	Elementary K-6 (2810)
6989536	Webb, Ryan Michael	Instructional	1	Health & Physical Educ PK-12 (4805)
2613297	Weeks, Rachel Nicole	Instructional	1	Grades PK-4 (2825)
2613297	Weeks, Rachel Nicole	Instructional	1	Special Education PK-8 (9226)
8219472	Weikert, Sarah E	Instructional	2	Art PK-12 (1405)
5204709	Weisz, Christopher Joseph	Instructional	2	Social Studies 7-12 (8875)
3715812	Welsh, Kristy	Instructional	2	Elementary K-6 (2810)
3715812	Welsh, Kristy	Instructional	2	Mid-Level Mathematics 6-9 (2860)

State ID	Employee Name	Certificate Type	Level Code	Certificate Description
3715812	Welsh, Kristy	Instructional	2	Mid-Level Science 6-9 (2880)
3715812	Welsh, Kristy	Instructional	2	Special Education PK-12 (9225)
1248284	Wesley, Mindy C	Educational Specialist	1	Elem. & Secondary School Counselor PK-12 (1839)
1248284	Wesley, Mindy C	Instructional	1	Special Education PK-12 (9225)
9382145	West, Megan Marie	Instructional	1	Grades 4-8 (All subjects 4-6, S Stud 7-8) (3100SS)
9895439	Whippo, Janet Demay	Instructional	2	Elementary K-6 (2810)
9895439	Whippo, Janet Demay	Instructional	2	Reading Specialist PK-12 (7650)
2354696	White, Andrew	Instructional	1	Elementary K-6 (2810)
8239726	Whitebread, Autumn Lee	Administrative	1	Principal PK-12 (1115)
8239726	Whitebread, Autumn Lee	Instructional	2	Elementary K-6 (2810)
8239726	Whitebread, Autumn Lee	Instructional	2	Mid-Level Science 6-9 (2880)
8239726	Whitebread, Autumn Lee	Instructional	2	Reading Specialist PK-12 (7650)
5452091	Whited, Barron Gene	Educational Specialist	2	Elementary School Counselor K-6 (1836)
5452091	Whited, Barron Gene	Educational Specialist	2	Secondary School Counselor 7-12 (1837)
9610585	Whitmore, Heather Anne	Instructional	1	Elementary K-6 (2810)
9610585	Whitmore, Heather Anne	Instructional	1	Reading Specialist PK-12 (7650)
5830501	Whitmoyer, Jessica Lynn	Educational Specialist	1	Inst Technology Specialist PK-12 (1825)
5830501	Whitmoyer, Jessica Lynn	Instructional	2	Social Studies 7-12 (8875)
	Whitted, Stephanie R	Instructional	1	English 7-12 (3230)
1961894	Whitten, Anne Starr	Instructional	2	Mid-Level English 6-9 (2850)
1961894	Whitten, Anne Starr	Instructional	2	Mid-Level Citiz. Ed 6-9 (2870)
6597585	Widdop, Christen Barbara	Instructional	2	Elementary K-6 (2810)
6597585	Widdop, Christen Barbara	Instructional	2	Special Education PK-12 (9225)
4914824	Widlund, Shari Rachel	Instructional	2	Elementary K-6 (2810)
4914824	Widlund, Shari Rachel	Instructional	HOUSSE Designation	Mid-Level English 6-9 (2850)
4914824	Widlund, Shari Rachel	Instructional	2	Mid-Level English 6-9 (2850)
4914824	Widlund, Shari Rachel	Instructional	HOUSSE Designation	English 7-12 (3230)
4914824	Widlund, Shari Rachel	Instructional	2	Special Education PK-12 (9225)
1735273	Williams, Kristina J	Instructional	2	Elementary K-6 (2810)
6109496	Williams, Marie	Administrative	1	Principal PK-12 (1115)
6109496	Williams, Marie	Instructional	2	Mathematics 7-12 (6800)
9083653	Williams, Rhonda Shellenberger	Administrative	1	Principal PK-12 (1115)
9083653	Williams, Rhonda Shellenberger	Instructional	2	Elementary K-6 (2810)
9083653	Williams, Rhonda Shellenberger	Instructional	2	Early Childhood N-3 (2840)
9083653	Williams, Rhonda Shellenberger	Instructional	2	Mid-Level English 6-9 (2850)
9083653	Williams, Rhonda Shellenberger	Instructional	2	English 7-12 (3230)
9083653	Williams, Rhonda Shellenberger	Instructional	2	Family-Consumer Sci PK-12 (5600)
9083653	Williams, Rhonda Shellenberger	Instructional	2	Social Studies 7-12 (8875)

State ID	Employee Name	Certificate Type	Level Code	Certificate Description
1767502	Willis, Shayna McCracken	Instructional	1	Mathematics 7-12 (6800)
1917905	Wilson, Lauren	Administrative	1	Principal PK-12 (1115)
1917905	Wilson, Lauren	Endorsement	Endorsement	Instructional Coach PK-12 (1182)
1917905	Wilson, Lauren	Instructional	2	Elementary K-6 (2810)
1917905	Wilson, Lauren	Instructional	2	Mid-Level Mathematics 6-9 (2860)
1917905	Wilson, Lauren	Instructional	2	Reading Specialist PK-12 (7650)
3060541	Wilson, Lynn A	Administrative	1	Principal PK-12 (1115)
3060541	Wilson, Lynn A	Instructional	2	Elementary K-6 (2810)
3060541	Wilson, Lynn A	Instructional	2	Mid-Level English 6-9 (2850)
3060541	Wilson, Lynn A	Instructional	2	English 7-12 (3230)
5179051	Wilson, Misty L	Instructional	1	English 7-12 (3230)
2786425	Wise, Ashley R	Instructional	2	Elementary K-6 (2810)
4652602	Witman, Morgan Rae	Instructional	2	English 7-12 (3230)
4652602	Witman, Morgan Rae	Supervisory		Supvr Special Education PK-12 (9215)
4652602	Witman, Morgan Rae	Instructional	2	Special Education PK-12 (9225)
1850535	Witmer, Lauren G	Instructional	2	Elementary K-6 (2810)
1850535	Witmer, Lauren G	Instructional	2	Early Childhood N-3 (2840)
3102191	Worrell, Kimberly A	Instructional	2	Mathematics 7-12 (6800)
5847123	Wright, Kathleen Ann	Endorsement	Endorsement	Instructional Coach PK-12 (1182)
5847123	Wright, Kathleen Ann	Private School - Asst or Teacher		Nursery/Kindergarten N-K (12833)
5847123	Wright, Kathleen Ann	Instructional	2	Elementary K-6 (2810)
5847123	Wright, Kathleen Ann	Instructional	2	Early Childhood N-3 (2840)
	Wrigley, Christopher S	Instructional	1	Elementary K-6 (2810)
7191053	Yadsko, Alexandria EmilyAnn	Instructional	1	Grades PK-4 (2825)
3059573	Yeager, Paola P	Instructional	1	Reading Specialist PK-12 (7650)
1787689	Young, Karenann S	Non-Certified Educator Designation		Non-Certified Educator PK-12 (20000)
6136347	Young, Sasha	Instructional	2	Elementary K-6 (2810)
6136347	Young, Sasha	Instructional	2	Special Education PK-12 (9225)
6456018	Zakielarz, Pamela Ashley	Educational Specialist	2	Secondary School Counselor 7-12 (1837)
5902961	Zanetti, Holli Ann	Instructional	2	Elementary K-6 (2810)
5902961	Zanetti, Holli Ann	Instructional	2	Reading Specialist PK-12 (7650)
2916741	Zeisloft, Roxanne Bogo	Educational Specialist	2	Elementary School Counselor K-6 (1836)
2916741	Zeisloft, Roxanne Bogo	Educational Specialist	2	Secondary School Counselor 7-12 (1837)
3861309	Zellers, Trisha Jane	Instructional		Elementary K-6 (2810)
3861309	Zellers, Trisha Jane	Instructional	HOUSSE Designation	English 7-12 (3230)
3861309	Zellers, Trisha Jane	Instructional		Ment and/or Phys Handicapped K-12 (9235)
8725829	Zollman, Jennifer L	Instructional	2	Elementary K-6 (2810)
8725829	Zollman, Jennifer L	Instructional	2	Special Education PK-12 (9225)



COMMONWEALTH OF PENNSYLVANIA  
DEPARTMENT OF EDUCATION  
333 Market Street Harrisburg, PA 17126-0333

Division of Federal Programs  
Consolidated Program Review

2019-2020 School Year

Agora Cyber CS  
590 North Gulph Road  
King of Prussia, PA 19406

LEA Level Monitoring

	<u>Name</u>	<u>Phone Number</u>	Check if Interviewed
<b>Superintendent:</b>	<u>Dr. Michael Conti</u>	<u>610-230-0079</u>	<input type="checkbox"/>
<b>Business Manager:</b>	<u>James Donovan</u>	<u>610-230-2248</u>	<input type="checkbox"/>
<b>Federal Program Coordinator:</b>	<u>Alina Kitchell</u>	<u>484-387-0109</u>	<input checked="" type="checkbox"/>
<b>Parent/Family Member:</b>	<u>Melissa Martinelli</u>	<u>610-368-6426</u>	<input type="checkbox"/>

**Program(s) Reviewed:**

- Title IA: Fiscal                       Title IVA: Fiscal  
 Title IIA: Fiscal  
 Title IIIA: Fiscal

**Program Reviewer(s):** Joe Roberts

**Program Review Date:** 04/23/2021

**Title IA: Fiscal**

**Component I: General Fiscal Requirements/Uniform Grants Guidance**

Fiscal monitoring is different than program monitoring: Fiscal monitoring will include a review of a subgrantee's financial operations, which may include a review of internal controls for program funds in accordance with state and federal requirements, an examination of principles, laws and regulations, and a determination of whether costs are reasonable and necessary to achieve program objectives. This activity involves an assessment of financial statements, records, and procedures. It is similar to an audit but has a lesser degree of detail and depth and, usually, a higher degree of frequency.

Fiscal monitoring includes, but is not limited to:

- Reviewing a random sample (usually 3-5 per program) of invoices or bills for expenditures charged to the program to determine if appropriate units of measure are reported and that costs (units x rate) are correct and that costs align with grant objectives and were approved in the application for funds.
- Comparing budgets or budget limits to actual costs to determine if the LEAs expenditures are likely to be more or less than budgeted
- Obtaining documentation that services billed or items purchased were actually delivered according to the contract
- Comparing invoices with supporting documentation to determine that costs were allowable, necessary, and allocable.

An expenditure is allowable if it is an approved use of funds under the statute or regulations governing a program and meet the intent of the program.

An expenditure is necessary if it is part of an approved application for funding.

An expenditure is allocable to the extent that the expenditure is used to meet the intent of the grant program (costs are pro-rated across grants if used to meet several grant program objectives).

Description	Requirements	Met	Not Met	N/A	Suggested Evidence of Implementation	Comments
-------------	--------------	-----	---------	-----	--------------------------------------	----------

Description	Requirements	Met	Not Met	N/A	Suggested Evidence of Implementation	Comments				
<p>1. Audits</p> <p>The SEA ensures that LEAs are audited annually, if required, and that all corrective actions identified through this process are fully implemented.  <b>NOTE: The most recent federal audit corrective actions may not be fully implemented if the audit was just completed in the last few months.</b>            Uniform Grants Guidance Section 200.501</p>	<p>1. Copies of single audit reports (2 most recent), corrective action plans and approval documents for the LEA</p>	<input checked="" type="checkbox"/>	<input type="checkbox"/>	<input type="checkbox"/>	<p><input checked="" type="checkbox"/> Two most recent audit reports (federal programs only, sections tabbed and marked)</p> <p><input type="checkbox"/> LEA response to findings</p> <p><input type="checkbox"/> PDE follow-up review of findings</p> <p><input type="checkbox"/> Independent auditor report shows that LEA has completed all corrective actions</p>					
<p>2. Equipment and Related Property</p> <p>UGG Sec. 200.313</p>	<p>1. LEA maintains Inventory records, purchase orders and receipts for equipment (over \$5,000) purchased and Computing Devices and Special Purpose Equipment (\$300 - \$4,999)</p>	<input type="checkbox"/>	<input type="checkbox"/>	<input checked="" type="checkbox"/>	<p><input type="checkbox"/> Inventory list of items purchased with Title I A.</p>	<table border="1"> <thead> <tr> <th data-bbox="1671 773 2062 824">District Comments</th> </tr> </thead> <tbody> <tr> <td data-bbox="1671 824 2062 1138"> <p>2/12/2020 10:42:33 AM            Controller James Donovan            Agora Cyber Charter School does not use Title I funds to purchase equipment, computing devices, or special purpose equipment.</p> </td> </tr> <tr> <th data-bbox="1671 1138 2062 1190">Monitor Comments</th> </tr> <tr> <td data-bbox="1671 1190 2062 1399"> <p>4/19/2021 12:39:58 PM            Monitor Joe Roberts            The LEA does not use Title I funds to purchase equipment.</p> </td> </tr> </tbody> </table>	District Comments	<p>2/12/2020 10:42:33 AM            Controller James Donovan            Agora Cyber Charter School does not use Title I funds to purchase equipment, computing devices, or special purpose equipment.</p>	Monitor Comments	<p>4/19/2021 12:39:58 PM            Monitor Joe Roberts            The LEA does not use Title I funds to purchase equipment.</p>
District Comments										
<p>2/12/2020 10:42:33 AM            Controller James Donovan            Agora Cyber Charter School does not use Title I funds to purchase equipment, computing devices, or special purpose equipment.</p>										
Monitor Comments										
<p>4/19/2021 12:39:58 PM            Monitor Joe Roberts            The LEA does not use Title I funds to purchase equipment.</p>										

Description	Requirements	Met	Not Met	N/A	Suggested Evidence of Implementation	Comments
	2. LEA conducts a physical inventory of all items every two years	<input type="checkbox"/>	<input type="checkbox"/>	<input checked="" type="checkbox"/>	<input type="checkbox"/> Documentation that physical inventory was conducted within the last two years	<p style="text-align: center;"><b>District Comments</b></p> <p>2/12/2020 10:42:54 AM Controller James Donovan Agora Cyber Charter School does not use Title I funds to purchase equipment, computing devices, or special purpose equipment.</p> <p style="text-align: center;"><b>Monitor Comments</b></p> <p>4/19/2021 12:40:46 PM Monitor Joe Roberts The LEA does not use Title I funds to purchase equipment.</p>
3. Obligating Funds UGG Sec. 200.309	1. LEA began obligating funds on or after the programs' approved/submit date	<input checked="" type="checkbox"/>	<input type="checkbox"/>	<input type="checkbox"/>	<input type="checkbox"/> List approval/submit date in comment section  <input checked="" type="checkbox"/> Documentation that program funds were not spent prior to program approval/submit date	
4. Record Retention UGG Sec. 200.333	1. Federal program records are maintained for a period of 7 years (current year plus 6 prior)	<input checked="" type="checkbox"/>	<input type="checkbox"/>	<input type="checkbox"/>	<input checked="" type="checkbox"/> Evidence that records are maintained for a period of seven years	
5. Performance Goal Reporting Verification UGG 200.328	1. LEA has submitted the Performance Goal Output Report, for the prior year, for Title IA. <b>Please note: the LEA does not need to provide copies of the Consolidated Application. The monitor will view prior to monitoring. By checking this as met you are ensuring compliance with this requirement.</b>	<input checked="" type="checkbox"/>	<input type="checkbox"/>	<input type="checkbox"/>	<input checked="" type="checkbox"/> Consolidated Application, Performance Goal Output Report in Title IA	

Description	Requirements	Met	Not Met	N/A	Suggested Evidence of Implementation	Comments
	2. Backup documentation exists for the performance goal report that aligns with the data indicated in the goals that would be used to determine success.	<input checked="" type="checkbox"/>	<input type="checkbox"/>	<input type="checkbox"/>	<input checked="" type="checkbox"/> Data reports/summaries must be present at time of monitoring.	
6. Conflict of Interest Policy UGG Sec 200.112	<p>1. Conflict of Interest Requirement the non-federal entity must disclose in writing any potential conflict of interest to the Federal awarding agency or pass-through entity in accordance with the applicable Federal awarding agency policy, which includes:</p> <ul style="list-style-type: none"> <li>• Standards of Conduct (covering conflicts of interest when governing the actions of its employees engaged in the selection award and administration of contracts)</li> <li>• Organizational Conflicts- (relationships with a parent company, affiliate, or subsidiary organization, the non-Federal entity is unable or appears to be unable to be impartial in conducting a procurement action involving a related organization)</li> <li>• Disciplinary Actions- (actions taken against an individual who violates the standards of conduct)</li> <li>• Mandatory Disclosure- (potential conflict disclosed in writing)</li> </ul>	<input checked="" type="checkbox"/>	<input type="checkbox"/>	<input type="checkbox"/>	<input checked="" type="checkbox"/> Board Approved policy, <input type="checkbox"/> Self-disclosure form,  <input type="checkbox"/> Resolution form or other evidence of how it was resolved (waived, or disciplinary actions taken)	

Description	Requirements	Met	Not Met	N/A	Suggested Evidence of Implementation	Comments
<p>7. Allowability of Costs</p> <p>UGG Sec 200.43</p>	<p>1. Allowability of Costs Requirement</p> <p>Expenditures must be aligned with approved budgeted items and when determining how the District expends its funds the procedures must include the following cost principles:</p> <ul style="list-style-type: none"> <li>• Necessary, reasonable and allocable</li> <li>• Conform with federal law and grant terms</li> <li>• Consistent with state and local policies</li> <li>• Adequately documented</li> </ul>	<input checked="" type="checkbox"/>	<input type="checkbox"/>	<input type="checkbox"/>	<ul style="list-style-type: none"> <li><input checked="" type="checkbox"/> Review program expenditures</li> <li><input type="checkbox"/> Review Allowability of Costs Procedures to check for internal controls relating to bulleted items.</li> </ul>	
<p>8. Procurement</p> <p>UGG Sec 200.320, 100.67, 200.88</p>	<p>1. Procurement the LEA maintains purchasing procedures</p> <p>Micro-purchases (purchase up to \$10,000)</p> <ul style="list-style-type: none"> <li>• Small Purchase (between \$10,000-\$250,000)</li> <li>• Sealed Bids (purchases over \$250,000 with formal advertising)</li> <li>• Competitive Proposals (more than one source submitting a proposal)</li> <li>• Non-competitive Proposals i.e. Sole Source (Solicitation of a proposal from only one source)</li> </ul>	<input checked="" type="checkbox"/>	<input type="checkbox"/>	<input type="checkbox"/>	<ul style="list-style-type: none"> <li><input checked="" type="checkbox"/> Procurement procedures exist and include the specific procedures to be followed internally for the five procurement levels</li> <li><input type="checkbox"/> Evidence that procurement procedures were followed for 3-5 tested random expenditures.</li> </ul>	

Description	Requirements	Met	Not Met	N/A	Suggested Evidence of Implementation	Comments
<p>9. Cash Management Procedures</p> <p>UGG Sec 200.305</p>	<p>1. Cash Management - the LEA must maintain written procedures to implement the following cash management requirements:</p> <ul style="list-style-type: none"> <li>• Reimbursements - explain what happens if the LEA is initially charging federal grant expenditures to nonfederal funds</li> <li>• Advances - explain what happens if the LEA receives advance payments of federal grant funds</li> <li>• Interest - explain how the LEA will manage interest earned on federal grant awards</li> </ul>	<input checked="" type="checkbox"/>	<input type="checkbox"/>	<input type="checkbox"/>	<p><input checked="" type="checkbox"/> Procedures are available that address the three components</p> <p><input type="checkbox"/> Evidence that LEA returned interest earned in excess of \$500 to federal government, if applicable</p>	
<p>10. Travel Reimbursement</p> <p>UGG Sec 200.474</p>	<p>1. Travel the LEA must have written travel policies for travel costs to be allowable</p> <ul style="list-style-type: none"> <li>• Types of travel (single day, overnight or out-of-state)</li> <li>• What expenses may be reimbursed (food, lodging, transportation, airfare)</li> <li>• What type of documentation is needed for reimbursement? (pre-approval travel form, receipts, post travel form)</li> </ul>	<input checked="" type="checkbox"/>	<input type="checkbox"/>	<input type="checkbox"/>	<p><input checked="" type="checkbox"/> Board approved policies available for review</p> <p><input type="checkbox"/> Samples of travel requests reviewed followed policy</p> <p><input type="checkbox"/> Prior written approval was obtained by PDE for out of state travel</p>	

Description	Requirements	Met	Not Met	N/A	Suggested Evidence of Implementation	Comments				
<p>11. Prior Written Approval for Various Expenditures UGG Sec 200.413, 200.474, 200.438, 200.439, 200.454</p>	<p>1. LEA must obtain prior written approval for the following expenditures:</p> <ul style="list-style-type: none"> <li>• Salaries of Administrative Staff (Clerical and Federal Program Coordinators) (200.413(c))</li> <li>• Out of State Travel for workshops/conferences (200.474)</li> <li>• Entertainment Costs (200.438)</li> <li>• Equipment (200.439)</li> <li>• Student Activity Costs</li> <li>• Memberships, subscriptions, and Professional Activities (200.454)</li> </ul>	<input checked="" type="checkbox"/>	<input type="checkbox"/>	<input type="checkbox"/>	<p><input type="checkbox"/> Items were included in approved consolidated application budgets and/or narratives</p> <p><input checked="" type="checkbox"/> Emails or other correspondence with regional coordinator requesting and receiving approval for expenditures.</p>					
<p>12. Carryover</p> <p>The LEA complies with the carryover provisions of Title I.</p> <p>Sec. 1127</p>	<p>1. LEAs with Title I allocations greater than \$50,000 per year have not carried over more than 15% of their allocation from one year to next unless the SEA has waived the limitation (allowable once every 3-year cycle if the SEA believes the request is reasonable and necessary</p>	<input checked="" type="checkbox"/>	<input type="checkbox"/>	<input type="checkbox"/>	<p><input checked="" type="checkbox"/> Consolidated Application Carryover section</p> <p><input type="checkbox"/> Waiver request and Carryover Waiver Approval Letter</p>					
<p>13. Rank Order</p> <p>The LEA ensures that it complies with the requirements of Title I when allocating funds to eligible school attendance areas or schools in rank order of poverty based on the number of children from low-income families who reside in an eligible school attendance area.</p> <p>Sec. 1113</p>	<p>1. The LEA must rank buildings highest to lowest based on poverty percentages. All buildings over 75% low-income must be served, regardless of grade span, in rank order. Buildings below 75% can be served in rank order in two manners, either still in rank order regardless of grade span, or by rank order within grade span." This can be marked N/A only if one of the following applies; the LEA has one building per grade span, the LEA is a single building, less than 1,000 district enrollment, or a Charter School.</p>	<input type="checkbox"/>	<input type="checkbox"/>	<input checked="" type="checkbox"/>	<p><input type="checkbox"/> Building Level Title I Expenditures</p>	<table border="1" style="width: 100%; border-collapse: collapse;"> <thead> <tr> <th data-bbox="1673 911 2049 959" style="background-color: #cccccc;">District Comments</th> </tr> </thead> <tbody> <tr> <td data-bbox="1673 959 2049 1203"> <p>2/12/2020 10:46:42 AM Controller James Donovan Agora Cyber Charter School is considered one building and ranking does not apply.</p> </td> </tr> <tr> <th data-bbox="1673 1203 2049 1252" style="background-color: #cccccc;">Monitor Comments</th> </tr> <tr> <td data-bbox="1673 1252 2049 1497"> <p>4/19/2021 12:41:31 PM Monitor Joe Roberts The LEA has no need to rank buildings since it is considered to be one building.</p> </td> </tr> </tbody> </table>	District Comments	<p>2/12/2020 10:46:42 AM Controller James Donovan Agora Cyber Charter School is considered one building and ranking does not apply.</p>	Monitor Comments	<p>4/19/2021 12:41:31 PM Monitor Joe Roberts The LEA has no need to rank buildings since it is considered to be one building.</p>
District Comments										
<p>2/12/2020 10:46:42 AM Controller James Donovan Agora Cyber Charter School is considered one building and ranking does not apply.</p>										
Monitor Comments										
<p>4/19/2021 12:41:31 PM Monitor Joe Roberts The LEA has no need to rank buildings since it is considered to be one building.</p>										



Description	Requirements	Met	Not Met	N/A	Suggested Evidence of Implementation	Comments				
	<p>2. Buildings above 75% low-income must be served and can only not be served after written approval has been established by PDE. If an LEA has a building over 75%, this cannot be marked N/A. <b>Please note: the LEA does not need to provide copies of the Consolidated Application as evidence. The monitor will view prior to monitoring. By checking this as met you are ensuring compliance with this requirement.</b></p>	<input type="checkbox"/>	<input type="checkbox"/>	<input checked="" type="checkbox"/>	<ul style="list-style-type: none"> <li><input type="checkbox"/> Consolidated Application, Selection of Schools</li> <li><input type="checkbox"/> Approval by Regional Coordinator and evidence of a supplemental program</li> </ul>	<table border="1" style="width: 100%; border-collapse: collapse;"> <thead> <tr> <th data-bbox="1673 131 2055 175" style="background-color: #cccccc;">District Comments</th> </tr> </thead> <tbody> <tr> <td data-bbox="1673 175 2055 423"> <p>2/12/2020 10:46:47 AM Controller James Donovan Agora Cyber Charter School is considered one building and ranking does not apply.</p> </td> </tr> <tr> <th data-bbox="1673 423 2055 467" style="background-color: #cccccc;">Monitor Comments</th> </tr> <tr> <td data-bbox="1673 467 2055 646"> <p>4/19/2021 12:41:58 PM Monitor Joe Roberts The LEA is considered to be one building.</p> </td> </tr> </tbody> </table>	District Comments	<p>2/12/2020 10:46:47 AM Controller James Donovan Agora Cyber Charter School is considered one building and ranking does not apply.</p>	Monitor Comments	<p>4/19/2021 12:41:58 PM Monitor Joe Roberts The LEA is considered to be one building.</p>
District Comments										
<p>2/12/2020 10:46:47 AM Controller James Donovan Agora Cyber Charter School is considered one building and ranking does not apply.</p>										
Monitor Comments										
<p>4/19/2021 12:41:58 PM Monitor Joe Roberts The LEA is considered to be one building.</p>										
	<p>3. Pre-kindergarten children are excluded from the poverty count of any school</p>	<input type="checkbox"/>	<input type="checkbox"/>	<input checked="" type="checkbox"/>	<ul style="list-style-type: none"> <li><input type="checkbox"/> PIMS Report on Economically Disadvantaged</li> <li><input type="checkbox"/> Other printed documentation showing Pre-K excluded from enrollment counts</li> </ul>	<table border="1" style="width: 100%; border-collapse: collapse;"> <thead> <tr> <th data-bbox="1673 664 2055 708" style="background-color: #cccccc;">District Comments</th> </tr> </thead> <tbody> <tr> <td data-bbox="1673 708 2055 958"> <p>2/12/2020 10:46:50 AM Controller James Donovan Agora Cyber Charter School is considered one building and ranking does not apply.</p> </td> </tr> <tr> <th data-bbox="1673 958 2055 1002" style="background-color: #cccccc;">Monitor Comments</th> </tr> <tr> <td data-bbox="1673 1002 2055 1214"> <p>4/19/2021 12:42:54 PM Monitor Joe Roberts The LEA excludes pre-kindergarten children from poverty count.</p> </td> </tr> </tbody> </table>	District Comments	<p>2/12/2020 10:46:50 AM Controller James Donovan Agora Cyber Charter School is considered one building and ranking does not apply.</p>	Monitor Comments	<p>4/19/2021 12:42:54 PM Monitor Joe Roberts The LEA excludes pre-kindergarten children from poverty count.</p>
District Comments										
<p>2/12/2020 10:46:50 AM Controller James Donovan Agora Cyber Charter School is considered one building and ranking does not apply.</p>										
Monitor Comments										
<p>4/19/2021 12:42:54 PM Monitor Joe Roberts The LEA excludes pre-kindergarten children from poverty count.</p>										

Description	Requirements	Met	Not Met	N/A	Suggested Evidence of Implementation	Comments
<p>14. Comparability</p> <p>The LEA complies with the comparability provisions of Title I</p> <p>Sec. 1118(c)</p>	<p>1. Title I Comparability Report comparing Title I schools to non-Title I schools reported to SEA annually in Pennsylvania and submitted by November 15 <b>Please note: the LEA does not need to provide evidence. Monitor will view prior to monitoring from the Comparability website. By checking this as met you are ensuring compliance with this requirement.</b></p>	<input checked="" type="checkbox"/>	<input type="checkbox"/>	<input type="checkbox"/>	<p><input type="checkbox"/> Detailed Data Sheet and Assurance page</p> <p><input checked="" type="checkbox"/> Assurance page for those LEAs that are exempt</p>	<p><b>District Comments</b></p> <p>2/12/2020 10:49:14 AM</p> <p>Controller James Donovan</p> <p>Agora Cyber Charter School submitted the November Comparability Assurance Report as required.</p>
<p>15. Compliance to Reservations</p> <p>The LEA complies with requirements regarding the reservation of funds.</p> <p>Sec. 1113(c)(3), 42 U.S.C 11432</p> <p>Sec. 1116(a)(3)</p>	<p>1. The LEA has reserved funds for Homeless students at both Title I served and non-Title I served buildings. This is a district-level reservation. <b>Please note: the LEA does not need to provide copies of the Consolidated Application as evidence. The monitor will view prior to monitoring. By checking this as met you are ensuring compliance with this requirement.</b></p>	<input checked="" type="checkbox"/>	<input type="checkbox"/>	<input type="checkbox"/>	<p><input type="checkbox"/> Consolidated Application Reservation of Funds page</p> <p><input type="checkbox"/> Consolidated Application Title I budget</p> <p><input checked="" type="checkbox"/> Statement of expenditures for homeless</p>	
	<p>2. LEAs receiving more than \$500,000 in Title I funds have reserved a minimum of 1% of the allocation for parent and family engagement and have distributed a minimum of 90% of those funds to the school level. A LEA may reserve more than 1% of the allocation. The 90% building-level allocation rule is only applicable against the original 1%, not any percentage above. <b>Please note: the LEA does not need to provide copies of the Consolidated Application as evidence. The monitor will view prior to monitoring. By checking this as met you are ensuring compliance with this requirement.</b></p>	<input checked="" type="checkbox"/>	<input type="checkbox"/>	<input type="checkbox"/>	<p><input checked="" type="checkbox"/> Consolidated Application, Reservation of Funds</p> <p><input type="checkbox"/> Procedure for allocation of at least 90% of Parent and Family Engagement funds to the school level must be demonstrated and applicable expenditures provided as evidence of compliance</p>	

Description	Requirements	Met	Not Met	N/A	Suggested Evidence of Implementation	Comments				
	3. LEA reserved appropriate funds for Neglected Institution served. (If not used, select NA)	<input type="checkbox"/>	<input type="checkbox"/>	<input checked="" type="checkbox"/>	<input type="checkbox"/> Statement of expenditures for Neglected Institution	<table border="1"> <tr> <td data-bbox="1675 131 2053 175"><b>District Comments</b></td> </tr> <tr> <td data-bbox="1675 183 2053 386">2/12/2020 10:50:23 AM Controller James Donovan As a cyber charter school, Agora does not serve neglected institutes.</td> </tr> <tr> <td data-bbox="1675 394 2053 438"><b>Monitor Comments</b></td> </tr> <tr> <td data-bbox="1675 446 2053 605">4/19/2021 12:43:24 PM Monitor Joe Roberts The LEA does not serve neglected institutions.</td> </tr> </table>	<b>District Comments</b>	2/12/2020 10:50:23 AM Controller James Donovan As a cyber charter school, Agora does not serve neglected institutes.	<b>Monitor Comments</b>	4/19/2021 12:43:24 PM Monitor Joe Roberts The LEA does not serve neglected institutions.
<b>District Comments</b>										
2/12/2020 10:50:23 AM Controller James Donovan As a cyber charter school, Agora does not serve neglected institutes.										
<b>Monitor Comments</b>										
4/19/2021 12:43:24 PM Monitor Joe Roberts The LEA does not serve neglected institutions.										
	4. The LEA has reserved funds for Foster students at both Title I served and non-Title I served buildings. This is a district-level reservation. (LEAs are not required to set aside funds for Foster students. This can be marked N/A If not used).	<input type="checkbox"/>	<input type="checkbox"/>	<input checked="" type="checkbox"/>	<input type="checkbox"/> Statement of expenditures for Foster	<table border="1"> <tr> <td data-bbox="1675 630 2053 673"><b>District Comments</b></td> </tr> <tr> <td data-bbox="1675 682 2053 922">2/12/2020 10:50:49 AM Controller James Donovan Agora Cyber Charter School serves foster students with LEA general funds.</td> </tr> <tr> <td data-bbox="1675 930 2053 974"><b>Monitor Comments</b></td> </tr> <tr> <td data-bbox="1675 982 2053 1141">4/19/2021 12:44:16 PM Monitor Joe Roberts The LEA does not set aside funds for foster students.</td> </tr> </table>	<b>District Comments</b>	2/12/2020 10:50:49 AM Controller James Donovan Agora Cyber Charter School serves foster students with LEA general funds.	<b>Monitor Comments</b>	4/19/2021 12:44:16 PM Monitor Joe Roberts The LEA does not set aside funds for foster students.
<b>District Comments</b>										
2/12/2020 10:50:49 AM Controller James Donovan Agora Cyber Charter School serves foster students with LEA general funds.										
<b>Monitor Comments</b>										
4/19/2021 12:44:16 PM Monitor Joe Roberts The LEA does not set aside funds for foster students.										

Description	Requirements	Met	Not Met	N/A	Suggested Evidence of Implementation	Comments
	5. If LEA has indicated the use of the Salary and Fringe Benefit set-aside on the Reservation of Funds worksheet, does documentation exist to show how the calculation was derived. (If not used, select NA)	<input type="checkbox"/>	<input type="checkbox"/>	<input checked="" type="checkbox"/>	<input type="checkbox"/> Spreadsheet demonstrating calculations	<p style="text-align: center;"><b>District Comments</b></p> <p>2/12/2020 10:51:21 AM Controller James Donovan Agora Cyber Charter School does not exercise the Salary and Fringe Benefit set-aside option.</p> <p style="text-align: center;"><b>Monitor Comments</b></p> <p>4/19/2021 12:45:00 PM Monitor Joe Roberts The LEA does not use either of the set asides.</p>
	6. The LEA indicated the use of Optional set asides, such as audit, community day programs, district wide professional development, pupil transportation, pre-school programs, program evaluation, summer and intersession programs, state and federal liaison on the set-aside Reservation of Funds worksheet.	<input type="checkbox"/>	<input type="checkbox"/>	<input checked="" type="checkbox"/>	<input type="checkbox"/> LEA Title I budget and expenditures	<p style="text-align: center;"><b>District Comments</b></p> <p>2/12/2020 10:52:59 AM Controller James Donovan Agora Cyber Charter School did not indicate the use of Optional set asides on the Reservation of Funds worksheet.</p> <p style="text-align: center;"><b>Monitor Comments</b></p> <p>4/19/2021 12:45:34 PM Monitor Joe Roberts The LEA does not use either of the set asides.</p>
16. Transferability Sec 5103(b)	1. Up to 100% of Title II and IV funds can be transferred. Funds can be transferred into Title I and Title III but not out of either subprogram. Title IIA and IV can transfer between programs.	<input checked="" type="checkbox"/>	<input type="checkbox"/>	<input type="checkbox"/>	<input checked="" type="checkbox"/> Expenditures aligned to transferred into subprogram  <input type="checkbox"/> Consolidated Application, Transferability page	

Description	Requirements	Met	Not Met	N/A	Suggested Evidence of Implementation	Comments				
	2. Evidence that Nonpublic school consultation to discuss transfer of funds occurred prior to the transfer of funds.	<input type="checkbox"/>	<input type="checkbox"/>	<input checked="" type="checkbox"/>	<input type="checkbox"/> Agendas/sign in sheets <input type="checkbox"/> Emails <input type="checkbox"/> Other documentation to reflect consultation occurred prior to the transfer of funds	<table border="1"> <thead> <tr> <th data-bbox="1673 128 2055 175">District Comments</th> </tr> </thead> <tbody> <tr> <td data-bbox="1673 175 2055 423">2/12/2020 10:53:49 AM Controller James Donovan Agora Cyber Charter School does not participate in any non-public school consultations.</td> </tr> <tr> <th data-bbox="1673 423 2055 470">Monitor Comments</th> </tr> <tr> <td data-bbox="1673 470 2055 651">4/19/2021 12:46:07 PM Monitor Joe Roberts The LEA does not service any non public students.</td> </tr> </tbody> </table>	District Comments	2/12/2020 10:53:49 AM Controller James Donovan Agora Cyber Charter School does not participate in any non-public school consultations.	Monitor Comments	4/19/2021 12:46:07 PM Monitor Joe Roberts The LEA does not service any non public students.
District Comments										
2/12/2020 10:53:49 AM Controller James Donovan Agora Cyber Charter School does not participate in any non-public school consultations.										
Monitor Comments										
4/19/2021 12:46:07 PM Monitor Joe Roberts The LEA does not service any non public students.										
If you have additional comments to make about this section, enter them here:										
17. Time Documentation UGG Section 200.430	1A. The LEA maintains semi-annual certifications for all employees paid through a federal grant and working on a single cost objective. Single funding certifications are signed after the fact by the employee or supervisor with direct knowledge of the employee's activities.	<input checked="" type="checkbox"/>	<input type="checkbox"/>	<input type="checkbox"/>	<input checked="" type="checkbox"/> Semi-annual time certifications					

Description	Requirements	Met	Not Met	N/A	Suggested Evidence of Implementation	Comments				
	1B. If LEA is using single funding certifications to document time for an employee with a fixed schedule, prior written approval from DFP was obtained.	<input type="checkbox"/>	<input type="checkbox"/>	<input checked="" type="checkbox"/>	<input type="checkbox"/> Documentation of Fixed schedule semi-annual time documentation DFP approval	<table border="1"> <tr> <th data-bbox="1667 121 2053 178">District Comments</th> </tr> <tr> <td data-bbox="1667 178 2053 427">2/12/2020 10:55:08 AM Controller James Donovan Agora Cyber Charter School is not using single funding certifications to document time.</td> </tr> <tr> <th data-bbox="1667 427 2053 483">Monitor Comments</th> </tr> <tr> <td data-bbox="1667 483 2053 691">4/19/2021 12:46:54 PM Monitor Joe Roberts The LEA does not use any single funding certs for time documentation.</td> </tr> </table>	District Comments	2/12/2020 10:55:08 AM Controller James Donovan Agora Cyber Charter School is not using single funding certifications to document time.	Monitor Comments	4/19/2021 12:46:54 PM Monitor Joe Roberts The LEA does not use any single funding certs for time documentation.
District Comments										
2/12/2020 10:55:08 AM Controller James Donovan Agora Cyber Charter School is not using single funding certifications to document time.										
Monitor Comments										
4/19/2021 12:46:54 PM Monitor Joe Roberts The LEA does not use any single funding certs for time documentation.										
	2. The LEA maintains Personnel Activity Reports (PARs) for employees who works on multiple cost objectives and are paid in full or in part from a federal grant. PARs include 100% of the employees time, are broken out by multiple cost objectives, are signed by the employee after the fact, are collected multiple times a year and are reconciled against payroll records so that the total amount charged to the federal grant is supported by the PARs.	<input type="checkbox"/>	<input type="checkbox"/>	<input checked="" type="checkbox"/>	<input type="checkbox"/> Time logs <input type="checkbox"/> Staff schedules	<table border="1"> <tr> <th data-bbox="1667 691 2053 748">District Comments</th> </tr> <tr> <td data-bbox="1667 748 2053 1029">2/12/2020 10:56:32 AM Controller James Donovan All Agora Cyber Charter School employees funded through Title I dedicate one hundred percent of their time to Title I activities.</td> </tr> <tr> <th data-bbox="1667 1029 2053 1086">Monitor Comments</th> </tr> <tr> <td data-bbox="1667 1086 2053 1292">4/19/2021 12:47:55 PM Monitor Joe Roberts The LEA employees dedicate all their time to Title I .</td> </tr> </table>	District Comments	2/12/2020 10:56:32 AM Controller James Donovan All Agora Cyber Charter School employees funded through Title I dedicate one hundred percent of their time to Title I activities.	Monitor Comments	4/19/2021 12:47:55 PM Monitor Joe Roberts The LEA employees dedicate all their time to Title I .
District Comments										
2/12/2020 10:56:32 AM Controller James Donovan All Agora Cyber Charter School employees funded through Title I dedicate one hundred percent of their time to Title I activities.										
Monitor Comments										
4/19/2021 12:47:55 PM Monitor Joe Roberts The LEA employees dedicate all their time to Title I .										

Desk Monitoring only:

[Title I uploads-Fiscal 2019-20.pdf](#)

- Upload inventory list for public and Non-public programs
- Upload data reports/summaries

Description	Requirements	Met	Not Met	N/A	Suggested Evidence of Implementation	Comments
	<ul style="list-style-type: none"> <li>• Upload Conflict of Interest Policy and Travel Reimbursement Policy, Cash Management Procedure, Allowability of Costs Procedure and Procurement Procedure</li> <li>• Upload Carryover Waiver Approval Letter, if applicable</li> <li>• Upload building level budgets for each Title I building</li> <li>• Upload Documentation of LEA methodology for allocating state and local funds to buildings.</li> <li>• For LEAs not exempt, upload Comparability Assurance page and Detailed data sheet. For those LEAs that are exempt, upload Assurance page.</li> <li>• Upload MOE letter from PDE</li> <li>• Upload agendas, sign in sheets, emails, or other documentation to reflect Non-public consultation occurred.</li> </ul>					

**Community Eligibility Provision (CEP) 7 CFR 245.9(f)97) (iii)**

The Healthy, Hunger-Free Kids Act of 2010 (Public Law 111-296) offers LEAs an alternative to collecting household applications in the National School Lunch and National School Breakfast Programs, which eliminates unnecessary paperwork previously required by the Richard B. Russell National School Lunch Act. The CEP is a reimbursement option for eligible LEAs and schools that wish to offer free meals to all children in high-poverty schools.

**If the LEA does not use the Community Eligibility Provision (CEP), this section can be skipped.**

Requirements	Met	Not Met	N/A	Suggested Evidence of Implementation	Comments
<p>1. Did your LEA have schools that participated in the Community Eligibility Provision (CEP) during the 18-19 SY? This is asked for 19-20 monitoring because data from the previous year is used for the current year Selection of Schools and Nonpublic Equitable Share data</p> <p>Note: If your LEA has schools that have adopted CEP for the first time during the 19-20 SY this answer is "no".                      Note: If a "no" answer the remaining questions can be marked N/A.</p> <p><b>Please note: the LEA does not need to provide copies of the Consolidated Application as evidence. The monitor will view prior to monitoring. By checking this as met you are ensuring compliance with this requirement.</b></p>	<input type="checkbox"/>	<input type="checkbox"/>	<input type="checkbox"/>	<p><input type="checkbox"/> Consolidated Application, Selection of Schools</p>	



Requirements	Met	Not Met	N/A	Suggested Evidence of Implementation	Comments
<p>2. LEA has a data source/process that was used to ensure that CEP building low-income data was uniform with other non-CEP buildings and/or was equitable in regard to nonpublic schools. <b>Please note: the LEA does not need to provide copies of the Consolidated Application as evidence. The monitor will view prior to monitoring. By checking this as met you are ensuring compliance with this requirement.</b></p>	<input type="checkbox"/>	<input type="checkbox"/>	<input type="checkbox"/>	<ul style="list-style-type: none"> <li><input type="checkbox"/> Consolidated Application Selection of Schools</li> <li><input type="checkbox"/> The 1.6 multiplier was applied against CEP data from participating schools to make it uniform with traditional Free and Reduced Lunch data at non-CEP schools.</li> <li><input type="checkbox"/> Raw CEP/Direct Certification (DC) data was utilized at all schools in a uniform manner without a multiplier and regardless of whether or not a school was CEP participating or not.</li> <li><input type="checkbox"/> A survey that looked like the old Free and Reduced lunch survey - but which made clear that it was not a requirement of the food subsidy program - was sent to participating CEP schools. Non-CEP schools would use the traditional free and reduced forms.</li> </ul>	

### Comments

The Lea has successfully completed all the requirements for Title I

## Title II A: Fiscal

### Requirements

Description	Requirements	Met	Not Met	N/A	Suggested Evidence of Implementation	Comments
<p>1. Supplement/Supplant</p> <p>The LEA ensures that Federal funds are used only to supplement or increase non-Federal sources used for the education of participating students and not to supplant funds from non-Federal sources</p> <p>Sec. 1118(b)</p>	<p>1. Title II - the LEA approved budget and records of expenditures of Title II funds match</p>	<input type="checkbox"/>	<input type="checkbox"/>	<input checked="" type="checkbox"/>	<p><input type="checkbox"/> Title II budgets</p> <p><input type="checkbox"/> LEA budget</p> <p><input type="checkbox"/> Statement of Expenditures for Title II</p>	<p style="text-align: center;"><b>District Comments</b></p> <p>2/12/2020 11:03:35 AM            Controller James Donovan            Agora Cyber Charter School implemented the transferability component and all Title II funds are transferred to Title I and used used for salaries and benefits.</p> <p style="text-align: center;"><b>Monitor Comments</b></p> <p>4/19/2021 12:30:45 PM            Monitor Joe Roberts            All Title II funds transferred to Title I.</p>
<p>2. Time Documentation</p> <p>UGG 200.430</p>	<p>1A. The LEA maintains semi-annual certifications for all employees paid through a federal grant and working on a single cost objective. Single funding certifications are signed after the fact by the employee or supervisor with direct knowledge of the employee's activities.</p>	<input checked="" type="checkbox"/>	<input type="checkbox"/>	<input type="checkbox"/>	<p><input checked="" type="checkbox"/> Semi-annual time certifications</p>	

Description	Requirements	Met	Not Met	N/A	Suggested Evidence of Implementation	Comments				
	1B. If LEA is using single funding certifications to document time for an employee with a fixed schedule, prior written approval from DFP was obtained.	<input type="checkbox"/>	<input type="checkbox"/>	<input checked="" type="checkbox"/>	<input type="checkbox"/> Documentation of Fixed schedule semi-annual time documentation DFP approval	<table border="1" style="width: 100%; border-collapse: collapse;"> <thead> <tr> <th data-bbox="1488 131 2049 180" style="text-align: center;">District Comments</th> </tr> </thead> <tbody> <tr> <td data-bbox="1488 180 2049 391">           2/12/2020 11:06:03 AM            Controller James Donovan            Agora Cyber Charter School is not using Single Funding Certifications to document time.         </td> </tr> <tr> <th data-bbox="1488 391 2049 440" style="text-align: center;">Monitor Comments</th> </tr> <tr> <td data-bbox="1488 440 2049 613">           4/19/2021 12:31:24 PM            Monitor Joe Roberts            The LEA does not use Single Funding Certs .         </td> </tr> </tbody> </table>	District Comments	2/12/2020 11:06:03 AM Controller James Donovan Agora Cyber Charter School is not using Single Funding Certifications to document time.	Monitor Comments	4/19/2021 12:31:24 PM Monitor Joe Roberts The LEA does not use Single Funding Certs .
District Comments										
2/12/2020 11:06:03 AM Controller James Donovan Agora Cyber Charter School is not using Single Funding Certifications to document time.										
Monitor Comments										
4/19/2021 12:31:24 PM Monitor Joe Roberts The LEA does not use Single Funding Certs .										
	2. The LEA maintains Personnel Activity Reports (PARs) for employees who works on multiple cost objectives and are paid in full or in part from a federal grant. PARs include 100% of the employees time, are broken out by multiple cost objectives, are signed by the employee after the fact, are collected multiple times a year and are reconciled against payroll records so that the total amount charged to the federal grant is supported by the PARs.	<input type="checkbox"/>	<input type="checkbox"/>	<input checked="" type="checkbox"/>	<input type="checkbox"/> Time logs <input type="checkbox"/> Staff schedules	<table border="1" style="width: 100%; border-collapse: collapse;"> <thead> <tr> <th data-bbox="1488 630 2049 678" style="text-align: center;">District Comments</th> </tr> </thead> <tbody> <tr> <td data-bbox="1488 678 2049 922">           2/12/2020 11:06:42 AM            Controller James Donovan            All Agora Cyber Charter School employees funded through Title II dedicate one hundred percent of their time to Title I activities.         </td> </tr> <tr> <th data-bbox="1488 922 2049 971" style="text-align: center;">Monitor Comments</th> </tr> <tr> <td data-bbox="1488 971 2049 1143">           4/23/2021 9:49:02 AM            Monitor Joe Roberts            All LEA employees spend 100 percent of their time in Title I activities         </td> </tr> </tbody> </table>	District Comments	2/12/2020 11:06:42 AM Controller James Donovan All Agora Cyber Charter School employees funded through Title II dedicate one hundred percent of their time to Title I activities.	Monitor Comments	4/23/2021 9:49:02 AM Monitor Joe Roberts All LEA employees spend 100 percent of their time in Title I activities
District Comments										
2/12/2020 11:06:42 AM Controller James Donovan All Agora Cyber Charter School employees funded through Title II dedicate one hundred percent of their time to Title I activities.										
Monitor Comments										
4/23/2021 9:49:02 AM Monitor Joe Roberts All LEA employees spend 100 percent of their time in Title I activities										

Description	Requirements	Met	Not Met	N/A	Suggested Evidence of Implementation	Comments					
3. Performance Goal Reporting Verification  UGG 200.328	1. LEA has submitted the Performance Goal Output Report for Title II by the due date. <b>Please note: the LEA does not need to provide copies of the Consolidated Application as evidence. The monitor will view prior to monitoring. By checking this as met you are ensuring compliance with this requirement.</b>	<input type="checkbox"/>	<input type="checkbox"/>	<input checked="" type="checkbox"/>	<input type="checkbox"/> Consolidated Application, Performance Goal Output Report in Title II.	<table border="1" style="width: 100%; border-collapse: collapse;"> <thead> <tr> <th data-bbox="1488 128 2049 180" style="text-align: center;">District Comments</th> </tr> </thead> <tbody> <tr> <td data-bbox="1488 180 2049 427">           2/12/2020 11:08:10 AM            Controller James Donovan            Agora Cyber Charter School implemented the transferability component and all Title II funds are transferred to Title I so a Title II performance goal was not needed.         </td> </tr> <tr> <td data-bbox="1488 427 2049 954">           4/3/2020 2:32:00 PM            Federal Programs Coordinator Alina Kitchell            As I was preparing for the desk audit I realized we did in fact have a performance goal included in the 18-19 consolidated application. I did submit the report prior to the January 4th deadline and the information is included in the Title II upload files. We did not include a Title II goal in the 19-20 consolidated application since I had checked at the PAFPC conference and they confirmed a goal was not needed if funds were transferred.         </td> </tr> <tr> <th data-bbox="1488 954 2049 1000" style="text-align: center;">Monitor Comments</th> </tr> <tr> <td data-bbox="1488 1000 2049 1177">           4/19/2021 12:32:49 PM            Monitor Joe Roberts            Goals are not needed since Title II funds were transferred to Title I.         </td> </tr> </tbody> </table>	District Comments	2/12/2020 11:08:10 AM Controller James Donovan Agora Cyber Charter School implemented the transferability component and all Title II funds are transferred to Title I so a Title II performance goal was not needed.	4/3/2020 2:32:00 PM Federal Programs Coordinator Alina Kitchell As I was preparing for the desk audit I realized we did in fact have a performance goal included in the 18-19 consolidated application. I did submit the report prior to the January 4th deadline and the information is included in the Title II upload files. We did not include a Title II goal in the 19-20 consolidated application since I had checked at the PAFPC conference and they confirmed a goal was not needed if funds were transferred.	Monitor Comments	4/19/2021 12:32:49 PM Monitor Joe Roberts Goals are not needed since Title II funds were transferred to Title I.
District Comments											
2/12/2020 11:08:10 AM Controller James Donovan Agora Cyber Charter School implemented the transferability component and all Title II funds are transferred to Title I so a Title II performance goal was not needed.											
4/3/2020 2:32:00 PM Federal Programs Coordinator Alina Kitchell As I was preparing for the desk audit I realized we did in fact have a performance goal included in the 18-19 consolidated application. I did submit the report prior to the January 4th deadline and the information is included in the Title II upload files. We did not include a Title II goal in the 19-20 consolidated application since I had checked at the PAFPC conference and they confirmed a goal was not needed if funds were transferred.											
Monitor Comments											
4/19/2021 12:32:49 PM Monitor Joe Roberts Goals are not needed since Title II funds were transferred to Title I.											

Description	Requirements	Met	Not Met	N/A	Suggested Evidence of Implementation	Comments
	2. Backup documentation exists for the performance goal report that aligns with the data indicated in the goals that would be used to determine success.	<input type="checkbox"/>	<input type="checkbox"/>	<input checked="" type="checkbox"/>	<input type="checkbox"/> Data reports/ summaries	<p style="text-align: center;"><b>District Comments</b></p> <p>2/12/2020 11:08:16 AM            Controller James Donovan            Agora Cyber Charter School implemented the transferability component and all Title II funds are transferred to Title I so a Title II performance goal was not needed.</p> <p style="text-align: center;"><b>Monitor Comments</b></p> <p>4/19/2021 12:33:42 PM            Monitor Joe Roberts            Documentation is not needed since all funds transferred to Title I.</p>
4. Equipment and Related Property  UGG 200.313	1. LEA maintains Inventory records, purchase orders and receipts for equipment (over \$5,000) purchased and Computing Devices and Special Purpose Equipment (\$300 - \$4,999)	<input type="checkbox"/>	<input type="checkbox"/>	<input checked="" type="checkbox"/>	<input type="checkbox"/> Inventory list of items purchased with Title IIA	<p style="text-align: center;"><b>District Comments</b></p> <p>2/12/2020 11:09:58 AM            Controller James Donovan            Agora Cyber Charter School does not use Title II funds for equipment and related property.</p> <p style="text-align: center;"><b>Monitor Comments</b></p> <p>4/19/2021 12:34:14 PM            Monitor Joe Roberts            The LEA does not se any Title II funds to purchase equipment.</p>
<p>Desk monitoring only:</p> <ul style="list-style-type: none"> <li>• Upload data reports supporting performance goal output report</li> <li>• Upload Title II budget</li> <li>• Appropriate Time Documentation</li> </ul>						<p><a href="#">Title II-Uploads-Fiscal 2019-20.pdf</a>  <a href="#">Single Certification SY 19-20 Semester 2.pdf</a>  <a href="#">Single Certification SY 19-20 Semester 1.pdf</a></p>

Description	Requirements	Met	Not Met	N/A	Suggested Evidence of Implementation	Comments
If you have additional comments to make about this section, enter them here:						

**Comments**

The Lea has successfully completed all the requirements for Title II.

# Title IVA: Fiscal

## Requirements

Description	Requirements	Met	Not Met	N/A	Suggested Evidence of Implementation	Comments
<p>1. Supplement/Supplant</p> <p>The LEA ensures that Federal funds are used only to supplement or increase non-Federal sources used for the education of participating students and not to supplant funds from non-Federal sources</p> <p>Sec. 1118(b)</p>	<p>1. Title IV (where applicable) - the LEA approved budget and records of expenditures of Title IV funds match.</p>	<input type="checkbox"/>	<input type="checkbox"/>	<input checked="" type="checkbox"/>	<p><input type="checkbox"/> Title IV budgets</p> <p><input type="checkbox"/> LEA budget</p> <p><input type="checkbox"/> Statement of Expenditures for Title IV</p>	<p><b>District Comments</b></p> <p>2/12/2020 11:12:38 AM Controller James Donovan Agora Cyber Charter School implemented the transferability component and all Title IV funds are transferred to Title I and all funds are used for salary and benefits.</p> <p><b>Monitor Comments</b></p> <p>4/19/2021 12:35:15 PM Monitor Joe Roberts All Title IV funds are transferred to TITLE I.</p>
<p>2. Performance Goal Reporting Verification</p> <p>UGG 200.328</p>	<p>1. LEA has submitted the Performance Goal Output Report for Title IV by the due date. <b>Please note: the LEA does not need to provide copies of the Consolidated Application as evidence. The monitor will view prior to monitoring. By checking this as met you are ensuring compliance with this requirement.</b></p>	<input type="checkbox"/>	<input type="checkbox"/>	<input checked="" type="checkbox"/>	<p><input type="checkbox"/> Consolidated Application, Performance Goal Output Report in Title IV.</p>	<p><b>District Comments</b></p> <p>2/12/2020 11:13:09 AM Controller James Donovan Agora Cyber Charter School implemented the transferability component and all Title IV funds are transferred to Title I so a Title IV performance goal was not needed.</p> <p><b>Monitor Comments</b></p> <p>4/19/2021 12:36:31 PM Monitor Joe Roberts All Title IV funds transferred to Title I.</p>

Description	Requirements	Met	Not Met	N/A	Suggested Evidence of Implementation	Comments				
	2. Backup documentation exists for the performance goal report that aligns with the data indicated in the goals that would be used to determine success.	<input type="checkbox"/>	<input type="checkbox"/>	<input checked="" type="checkbox"/>	<input type="checkbox"/> Data reports/ summaries	<table border="1"> <tr> <th data-bbox="1619 131 2049 180">District Comments</th> </tr> <tr> <td data-bbox="1619 180 2049 496">2/12/2020 11:13:33 AM Controller James Donovan Agora Cyber Charter School implemented the transferability component and all Title IV funds are transferred to Title I so a Title IV performance goal was not needed.</td> </tr> <tr> <th data-bbox="1619 496 2049 545">Monitor Comments</th> </tr> <tr> <td data-bbox="1619 545 2049 719">4/19/2021 12:36:59 PM Monitor Joe Roberts All Title IV funds transferred to Title I</td> </tr> </table>	District Comments	2/12/2020 11:13:33 AM Controller James Donovan Agora Cyber Charter School implemented the transferability component and all Title IV funds are transferred to Title I so a Title IV performance goal was not needed.	Monitor Comments	4/19/2021 12:36:59 PM Monitor Joe Roberts All Title IV funds transferred to Title I
District Comments										
2/12/2020 11:13:33 AM Controller James Donovan Agora Cyber Charter School implemented the transferability component and all Title IV funds are transferred to Title I so a Title IV performance goal was not needed.										
Monitor Comments										
4/19/2021 12:36:59 PM Monitor Joe Roberts All Title IV funds transferred to Title I										
3. Time Documentation UGG 200.430	1A. The LEA maintains semi-annual certifications for all employees paid through a federal grant and working on a single cost objective. Single funding certifications are signed after the fact by the employee or supervisor with direct knowledge of the employee's activities.	<input checked="" type="checkbox"/>	<input type="checkbox"/>	<input type="checkbox"/>	<input checked="" type="checkbox"/> Semi-annual time certifications					
	1B. If LEA is using single funding certifications to document time for an employee with a fixed schedule, prior written approval from DFP was obtained.	<input type="checkbox"/>	<input type="checkbox"/>	<input checked="" type="checkbox"/>	<input type="checkbox"/> Documentation of Fixed schedule semi-annual time documentation DFP approval	<table border="1"> <tr> <th data-bbox="1619 995 2049 1044">District Comments</th> </tr> <tr> <td data-bbox="1619 1044 2049 1255">2/12/2020 11:14:36 AM Controller James Donovan Agora Cyber Charter School is not using single funding certification to document time.</td> </tr> <tr> <th data-bbox="1619 1255 2049 1304">Monitor Comments</th> </tr> <tr> <td data-bbox="1619 1304 2049 1474">4/19/2021 12:37:41 PM Monitor Joe Roberts The LEA does not use single funding certs to document time.</td> </tr> </table>	District Comments	2/12/2020 11:14:36 AM Controller James Donovan Agora Cyber Charter School is not using single funding certification to document time.	Monitor Comments	4/19/2021 12:37:41 PM Monitor Joe Roberts The LEA does not use single funding certs to document time.
District Comments										
2/12/2020 11:14:36 AM Controller James Donovan Agora Cyber Charter School is not using single funding certification to document time.										
Monitor Comments										
4/19/2021 12:37:41 PM Monitor Joe Roberts The LEA does not use single funding certs to document time.										



Description	Requirements	Met	Not Met	N/A	Suggested Evidence of Implementation	Comments
	2. The LEA maintains Personnel Activity Reports (PARs) for employees who works on multiple cost objectives and are paid in full or in part from a federal grant. PARs include 100% of the employees time, are broken out by multiple cost objectives, are signed by the employee after the fact, are collected multiple times a year and are reconciled against payroll records so that the total amount charged to the federal grant is supported by the PARs.	<input type="checkbox"/>	<input type="checkbox"/>	<input checked="" type="checkbox"/>	<input type="checkbox"/> Time logs <input type="checkbox"/> Staff schedules	<p style="text-align: center;"><b>District Comments</b></p> <p>2/12/2020 11:15:36 AM            Controller James Donovan            All Agora Cyber Charter School employees funded by Title IV dedicate one hundred percent of their time to Title I activities.</p> <p style="text-align: center;"><b>Monitor Comments</b></p> <p>4/19/2021 12:38:30 PM            Monitor Joe Roberts            All employees dedicate 100 per cent of their time to Title I. They use signed time certifications.</p>
4. Equipment and Related Property  UGG 200.313	1. LEA maintains Inventory records, purchase orders and receipts for equipment (over \$5,000) purchased and Computing Devices and Special Purpose Equipment (\$300 - \$4,999)	<input type="checkbox"/>	<input type="checkbox"/>	<input checked="" type="checkbox"/>	<input type="checkbox"/> Inventory list of items purchased with Title IV	<p style="text-align: center;"><b>District Comments</b></p> <p>2/12/2020 11:16:07 AM            Controller James Donovan            Agora Cyber Charter School does not use Title IV funds for equipment and related property.</p> <p style="text-align: center;"><b>Monitor Comments</b></p> <p>4/19/2021 12:39:02 PM            Monitor Joe Roberts            The LEA does not use Title IV funds to purchase equipment.</p>

Desk monitoring only:

- Upload data reports supporting performance goal output report
- Upload Title IV budget
- Appropriate Time Documentation

[Title IV-Uploads-Fiscal 2019-20.pdf](#)  
[Single Certification SY 19-20 Semester 2.pdf](#)  
[Single Certification SY 19-20 Semester 1.pdf](#)

Description	Requirements	Met	Not Met	N/A	Suggested Evidence of Implementation	Comments
If you have additional comments to make about this section, enter them here:						

**Comments**

The Lea has successfully completed all the requirements for Title IV

## Personnel Interviews

Building	Date	Staff Member Interviewed	Staff Member Position
No interviews have been entered.			

**Division of Federal Program  
Consolidated Program Review  
2019-2020 School Year  
Agora Cyber CS**

**Agora Cyber Charter School**

**SCHOOL Level Monitoring**

	<b>Name</b>	<b>Check if Interviewed</b>
Principal:	<u>Dr. Rich Jensen</u>	<input checked="" type="checkbox"/>
Parent:	<u>Melissa Martinelli</u>	<input type="checkbox"/>
Parent:	_____	<input type="checkbox"/>
Parent:	_____	<input type="checkbox"/>
Parent:	_____	<input type="checkbox"/>
Parent:	_____	<input type="checkbox"/>

Program Reviewers: Joe Roberts                      Visit Date: 4/23/2021

## School Level Monitoring

### Component I: Requirements

Description	Requirements	Met	Not Met	N/A	Suggested Evidence of Implementation	Comments				
1. Time Documentation UGG Sec. 200.430	1A. The LEA maintains semi-annual certifications for all employees paid through a federal grant and working on a single cost objective. Single funding certifications are signed after the fact by the employee or supervisor with direct knowledge of the employee's activities.	<input checked="" type="checkbox"/>	<input type="checkbox"/>	<input type="checkbox"/>	<input checked="" type="checkbox"/> Semi-annual time certifications					
	1B. If LEA is using single funding certifications to document time for an employee with a fixed schedule, prior written approval from DFP was obtained.	<input type="checkbox"/>	<input type="checkbox"/>	<input checked="" type="checkbox"/>	<input type="checkbox"/> Documentation of Fixed schedule semi-annual time documentation DFP approval	<table border="1"> <thead> <tr> <th>District Comments</th> </tr> </thead> <tbody> <tr> <td>4/12/2021 2:37:50 PM Federal Programs Coordinator Alina Kitchell Agora Cyber Charter School Title Funded Staff spend 100% of their time and effort in those Title positions.</td> </tr> <tr> <th>Monitor Comments</th> </tr> <tr> <td>4/23/2021 9:47:45 AM Monitor Joe Roberts The Lea employees spend 100 per cent of their time in their Title I positions.</td> </tr> </tbody> </table>	District Comments	4/12/2021 2:37:50 PM Federal Programs Coordinator Alina Kitchell Agora Cyber Charter School Title Funded Staff spend 100% of their time and effort in those Title positions.	Monitor Comments	4/23/2021 9:47:45 AM Monitor Joe Roberts The Lea employees spend 100 per cent of their time in their Title I positions.
District Comments										
4/12/2021 2:37:50 PM Federal Programs Coordinator Alina Kitchell Agora Cyber Charter School Title Funded Staff spend 100% of their time and effort in those Title positions.										
Monitor Comments										
4/23/2021 9:47:45 AM Monitor Joe Roberts The Lea employees spend 100 per cent of their time in their Title I positions.										

Description	Requirements	Met	Not Met	N/A	Suggested Evidence of Implementation	Comments				
	2. The LEA maintains Personnel Activity Reports (PARs) for employees who works on multiple cost objectives and are paid in full or in part from a federal grant. PARs include 100% of the employees time, are broken out by multiple cost objectives, are signed by the employee after the fact, are collected multiple times a year and are reconciled against payroll records so that the total amount charged to the federal grant is supported by the PARs.	<input type="checkbox"/>	<input type="checkbox"/>	<input checked="" type="checkbox"/>	<input type="checkbox"/> Time logs <input type="checkbox"/> Staff schedules	<table border="1"> <thead> <tr> <th data-bbox="1646 128 2049 180">District Comments</th> </tr> </thead> <tbody> <tr> <td data-bbox="1646 180 2049 461">           4/12/2021 2:38:33 PM            Federal Programs            Coordinator Alina Kitchell            Agora Cyber Charter School            Title Funded Staff spend            100% of their time and effort            in those Title positions.         </td> </tr> <tr> <th data-bbox="1646 461 2049 513">Monitor Comments</th> </tr> <tr> <td data-bbox="1646 513 2049 686">           4/23/2021 9:46:53 AM            Monitor Joe Roberts            The Lea employees spend            100% of their time on Title I.         </td> </tr> </tbody> </table>	District Comments	4/12/2021 2:38:33 PM Federal Programs Coordinator Alina Kitchell Agora Cyber Charter School Title Funded Staff spend 100% of their time and effort in those Title positions.	Monitor Comments	4/23/2021 9:46:53 AM Monitor Joe Roberts The Lea employees spend 100% of their time on Title I.
District Comments										
4/12/2021 2:38:33 PM Federal Programs Coordinator Alina Kitchell Agora Cyber Charter School Title Funded Staff spend 100% of their time and effort in those Title positions.										
Monitor Comments										
4/23/2021 9:46:53 AM Monitor Joe Roberts The Lea employees spend 100% of their time on Title I.										
2. Building Level Budget	1. The LEA and Title I School maintain a building level budget documenting <b>ALL</b> Title I expenditures	<input checked="" type="checkbox"/>	<input type="checkbox"/>	<input type="checkbox"/>	<input checked="" type="checkbox"/> School's Title I building level budget including specific salary and benefits for personnel and supply orders for actual and anticipated expenditures, must be used for this analysis					
<p>Desk Monitoring Only:</p> <ul style="list-style-type: none"> <li>• Upload staff semi-annual certification and/or time logs</li> <li>• Upload schools Title I building level budget including specific salary and benefits for personnel and supply orders for actual and anticipated expenditures.</li> </ul>						<a href="#">school level monitoring.pdf</a>				
If you have additional comments to make about this section, enter them here:										

## Comments

The Lea has successfully completed all the requirements for school level monitoring.



## INDEPENDENT AUDITOR'S REPORT

January 14, 2022

To the Board of Trustees  
Agora Cyber Charter School  
King of Prussia, Pennsylvania

### Report on Financial Statements

We have audited the accompanying financial statements of the Agora Cyber Charter School ("the School"), a nonprofit organization, which comprise the statement of financial position as of June 30, 2021, and the related statements of activities, functional expenses, and cash flows for the year then ended, and the related notes to the financial statements.

### Management's Responsibility for the Financial Statements

Management is responsible for the preparation and fair presentation of these financial statements in accordance with accounting principles generally accepted in the United States of America; this includes the design, implementation, and maintenance of internal control relevant to the preparation and fair presentation of financial statements that are free from material misstatement, whether due to fraud or error.

### Auditor's Responsibility

Our responsibility is to express an opinion on these financial statements based on our audit. We conducted our audit in accordance with auditing standards generally accepted in the United States of America and the standards applicable to financial audits contained in *Government Auditing Standards*, issued by the Comptroller General of the United States. Those standards require that we plan and perform the audit to obtain reasonable assurance about whether the financial statements are free from material misstatement.

An audit involves performing procedures to obtain audit evidence about the amounts and disclosures in the financial statements. The procedures selected depend on the auditor's judgment, including the assessment of the risks of material misstatement of the financial statements, whether due to fraud or error. In making those risk assessments, the auditor considers internal control relevant to the entity's preparation



and fair presentation of the financial statements in order to design audit procedures that are appropriate in the circumstances, but not for the purpose of expressing an opinion on the effectiveness of the entity's internal control. Accordingly, we express no such opinion. An audit also includes evaluating the appropriateness of accounting policies used and the reasonableness of significant accounting estimates made by management, as well as evaluating the overall presentation of the financial statements.

We believe that the audit evidence we have obtained is sufficient and appropriate to provide a basis for our audit opinion.

#### Opinion

In our opinion, the financial statements referred to above present fairly, in all material respects, the financial position of the Agora Cyber Charter School as of June 30, 2021, and the changes in its net assets and its cash flows for the year then ended in conformity with accounting principles generally accepted in the United States of America.

#### Report on Summarized Comparative Information

We have previously audited the Agora Cyber Charter School's June 30, 2020 financial statements, and we expressed an unmodified opinion on those audited financial statements in our report dated January 21, 2021. In our opinion, the summarized comparative information presented herein as of and for the year ended June 30, 2020 is consistent, in all material respects, with the audited financial statements from which it has been derived.

#### Other Matters

##### *Other Information*

Our audit was conducted for the purpose of forming an opinion on the financial statements as a whole. The accompanying schedule of expenditures of federal awards, as required by Title 2 U.S. Code of Federal Regulations (CFR) Part 200, *Uniform Administrative Requirements, Cost Principles, and Audit Requirements for Federal Awards* ("Uniform Guidance"), is presented for purposes of additional analysis and is not a required part of the financial statements. Such information is the responsibility of management and was derived from and relates directly to the underlying accounting and other records used to prepare the financial statements. The information has been subjected to the auditing procedures applied in the audit of the financial statements and certain additional procedures, including comparing and reconciling such information directly to the underlying accounting and other records used to prepare the financial statements or to the financial statements themselves, and other additional procedures in accordance with auditing standards generally accepted in the United States of America. In our opinion, the schedule of expenditures of federal awards is fairly stated, in all material respects, in relation to the financial statements as a whole.

#### Other Reporting Required by Government Auditing Standards

In accordance with *Government Auditing Standards*, we have also issued our report dated January 14, 2022, on our consideration of the School's internal control over financial reporting and on our tests of its compliance with certain provisions of laws, regulations, contracts, and grant agreements and other

To the Board of Trustees  
Agora Cyber Charter School

matters. The purpose of that report is solely to describe the scope of our testing of internal control over financial reporting and compliance and the results of that testing, and not to provide an opinion on the effectiveness of internal control over financial reporting or on compliance. That report is an integral part of an audit performed in accordance with Government Auditing Standards in considering the School's internal control over financial reporting and compliance.

*Barbacane, Thornton & Company LLP*  
BARBACANE, THORNTON & COMPANY LLP



April 12, 2019

Dr. Michael Conti  
Chief Executive Officer  
Agora Cyber CS  
1018 West 8th Street  
King of Prussia, Pa 19406

Dear Dr. Conti:

Enclosed is the Report of Findings presenting results of the cyclical monitoring which was conducted by the Bureau of Special Education (BSE) in the Agora Cyber CS the week of January 14, 2019.

The Executive Summary is arranged in two parts and includes an Appendix. PART I presents the Summary of Findings including an explanation of the review process and general findings. PART II describes the corrective action process. A description identifying findings of noncompliance, corrective action required, improvement planning needed, and results of interviews of staff and parents can be found in the Appendix. The charter school must complete corrective action within the calendar days as outlined in the Charter School Corrective Action Verification/Compliance and Improvement Plan developed with the BSE Adviser. Follow-up onsite reviews verifying the charter school's completion of corrective action will be conducted by the BSE. The BSE Adviser will contact the charter school to schedule the initial visit within 60 days of issuance of the monitoring report.

34 CFR 300.600 mandates the BSE to carry out monitoring activities and implementation of any necessary corrective action. Legal compliance is the basis on which high quality programs are built. It is policy of the Department of Education to promote and ensure compliance with special education statutes and regulations through an array of activities such as a coordinated program of plan review, compliance monitoring, technical assistance, and funding decisions. However, if the Department does not succeed in obtaining prompt compliance through activities such as monitoring, then more rigorous steps can be taken to make sure compliance is resolved. These include:

- Disapproval or rescinded approval of the local special education plan
- Deferment of the disbursement of state or federal funds pending resolution of the issue
- Reduction of the amount of funds (for example, by the amount of money it takes to provide an appropriate education to a particular child or children) if a charter school is unwilling to provide appropriate services

None of these steps are desirable and none should be necessary if each charter school is familiar with and attentive to the rules governing special education.

If you have any questions about this report, contact Dr. Beth Marvin, the Chairperson of the compliance monitoring team.

Please convey my thanks to all staff who participated in the review. Their time and assistance is appreciated.

Sincerely,

Patricia Hozella  
Interim Director

Attachments: Executive Summary  
Appendix: Detailed Report of Findings, Including Corrective Actions Required

CC: Chairperson  
Jill Deitrich  
CS Monitoring File



**Executive Summary  
BSE Compliance Monitoring Review  
of the  
Agora Cyber CS**

**PART I  
SUMMARY OF FINDINGS**

**A. Review Process**

Prior to the Bureau's monitoring the week of January 14, 2019, the Agora Cyber CS was formally notified of the dates the onsite review would be conducted. Notice and invitation to comment was also provided to the Local Task Force on Right-to-Education. The charter school was informed of its responsibility to compile various reports, written policies, and procedures to document compliance with requirements.

While onsite, the monitoring team employed a variety of techniques to gain an in depth understanding of the charter school's program operations. This included:

- Interviews of charter school administrative and instructional personnel
- Review of policies, notices, plans, outcome and performance data, special education forms and formats, and data reports used and compiled by the charter school (Facilitated Self-Assessment)
- Comprehensive case studies (including classroom observations, student file reviews, and interviews of parents and general and special education teachers).

**B. General Findings**

In reaching compliance determinations, the Bureau of Special Education (BSE) monitoring teams apply criteria contained in federal and state special education regulations. Specifically, these are:

- Individuals with Disabilities Education Improvement Act of 2004
- 22 Pa. Code Chapter 711
- 34 CFR Part 300

This report focuses on compliance with regulatory requirements and also contains descriptive information (such as interview and survey results) intended to provide feedback to assist in program planning.

**C. Overall Findings**

**1. FACILITATED SELF ASSESSMENT (FSA)**

The team reviewed the FSA submitted by the charter school and conducted onsite verification activities of the information submitted in the FSA. The onsite verification activities included review of policies, notices, procedures, and file reviews.

<b>FSA</b>	<b>In Compliance</b>	<b>Out of Compliance</b>
Assistive Technology and Services; Hearing Aids	2	0
Positive Behavior Support Policy	1	0
Child Find (Annual Public Notice and General Dissemination Materials)	1	0
Confidentiality	1	0
Dispute Resolution (Due process hearing decision implementation)	0	0
Exclusions: Suspensions and Expulsions (Procedural Requirements)	0	0
Independent Education Evaluation	1	0
Least Restrictive Environment (LRE)	1	0
Provision of Extended School Year Services	1	0
Provision of Related Service Including Psychological Counseling	1	0
Parent Training	1	0
Public School Enrollment	1	0
Surrogate Parents (Students Requiring)	1	0
Personnel Training	1	0
Intensive Interagency Approach	0	0
Summary of Academic Achievement and Functional Performance/Procedural Safeguard Requirements for Graduation	1	0
SPP/APR Indicator 13 (Transition)	0	1
Disproportionate Representation that is the Result of Inappropriate Identification	1	0

<b>IMPROVEMENT PLAN REQUIRED*</b>	<b>Yes</b>	<b>No</b>
Effective Use of Dispute Resolution	0	0
Graduation Rates (SPP)	1	0
Dropout Rates (SPP)	1	0
Suspensions (Rates)	0	0
Least Restrictive Environment (LRE) (SPP)	1	0
Participation in PSSA and PASA (SPP)	1	0
Participation in Charter-Wide Assessment	0	1
Public School Enrollment	0	1
Disproportionate Representation that is the Result of Inappropriate Identification	0	1

\*This determination is based on the data used for the monitoring. More recent data provided by the LEA may demonstrate that the LEA does not require an improvement plan for this topic. Please refer to the Corrective Action Verification/Compliance and Improvement Plan for final guidance.

**2. FILE REVIEW (Student case studies)**

The education records of randomly selected students participating in special education programs were studied to determine whether the charter school complied with essential requirements.

The status of compliance of the Agora Cyber CS is as follows:

<b>Sections of the FILE REVIEW</b>	<b>In Compliance</b>	<b>Out of Compliance</b>	<b>NA</b>
Essential Student Documents Are Present and Were Prepared Within Timelines	85	2	73
Evaluation/Reevaluation: Process and Content	219	1	560
Individualized Education Program: Process and Content	532	2	266
Procedural Safeguards: Process and Content	115	4	1
<b>TOTALS</b>	<b>951</b>	<b>9</b>	<b>900</b>

**3. TEACHER AND PARENT INTERVIEWS**

Interviews were conducted with parents and teachers of students selected by the BSE for the sample group. The goal is to determine if the charter school involves parents and professionals in required processes (e.g., evaluation, IEP development), whether programs and services are being provided, and whether the charter school provides training to enhance knowledge. Parent and teacher satisfaction with the special education program is also generally assessed.

	<b># Yes Responses</b>	<b># No Responses</b>	<b># of Other Responses</b>
Program Implementation: General Ed Teacher Interviews	146	5	47
Program Implementation: Special Ed Teacher Interviews	316	5	125
Program Implementation: Parent Interviews	131	14	88
<b>TOTALS</b>	<b>593</b>	<b>24</b>	<b>260</b>

**4. CLASSROOM OBSERVATIONS**

Observations are conducted in classrooms of students selected by the BSE for the sample group.

	<b># Yes Responses</b>	<b># No Responses</b>	<b># of Other Responses</b>
Classroom Observations	0	0	0

**5. EDUCATIONAL BENEFIT REVIEW**

	<b>In Compliance</b>	<b>Out of Compliance</b>
Educational Benefit Review	X	

**PART II  
CORRECTIVE ACTION PROCESS**

PART I of this report presented an overall summary of findings. In the Appendix to the report, we have provided the detailed findings for each of the criteria of the compliance monitoring document, i.e. FSA, File Reviews, Interviews and Classroom Observations. The detailed report of findings includes:

- Criteria Number
- Statements of all requirements
- Whether each requirement was met, not met, not applicable or other
- Statements of corrective action required for those criteria not met. *Criteria not met that require corrective action by the charter school are gray-shaded.*

***Charter schools are advised that in accordance with requirements of the Individuals with Disabilities Education Act, all noncompliance must be corrected as soon as possible but in no case later than one year from the date of the monitoring report.*** The BSE is required to verify timely correction of noncompliance, and must report annually to the federal government and the public on this requirement.

Upon receipt of this report, the charter school should review the corrective action and improvement planning required. The report is formatted so that findings from all components of the monitoring are consolidated by topical area. The report lists the finding, and whether corrective action is required. For certain types of findings, corrective action will be prescribed, and will not vary from charter school to charter school. For example, if the finding is that the charter school lacks a specific required policy, it is reasonable to have the BSE prescribe a standardized remedy and timeline for correcting this deficiency. However, the majority of corrective action activities will be individually designed by the charter school based on their own unique circumstances and goals. Consistent with IDEA's general supervision requirements for states, BSE must approve all proposed corrective action.

With respect to the File Review, because students were selected at random, findings are generalized to the entire population of students with disabilities. During the corrective action review, the BSE Advisor will select students at random and will review updated data, i.e. records that were developed subsequent to the monitoring. Consequently, the charter school should approach corrective action on a systemic basis. As indicated above, the charter school is also required to correct student specific noncompliance identified during monitoring under the ICAP process. If there has been a finding of noncompliance in the Educational Benefit Review component, the individual students are identified to the charter school and, because of the significance of the provision of a free appropriate public education (FAPE) to these students; the charter school must take immediate corrective action.

The BSE Adviser will schedule an onsite visit with the charter school within 60 days following issuance of the monitoring report. The BSE Adviser, charter school, and PaTTAN staff will develop a Charter School Corrective Action Verification/Compliance and Improvement Plan. PaTTAN and IU staff are available to assist the charter school.

Upon conclusion of the corrective action process, the charter school will be notified of its successful completion of the monitoring process.

## Charter School Corrective Action Verification/Compliance and Improvement Plan - Bureau of Special Education

This form is designed to serve both as a planning tool and as verification of completion of corrective action.

Charter School: Agora Cyber CS

Chief Executive Officer: Dr. Michael Conti

Special Education Director/Coordinator: \_\_\_\_\_

BSE Special Education Adviser: Dr. Beth Marvin

Date of Report: April 12, 2019

Date Final Report Sent to LEA: April 12, 2019

**Reminder: The timelines for corrective action of all non-compliance items may not exceed ONE YEAR from the Date Final Report Sent to LEA**

First Visit Date: \_\_\_\_\_

Y	N	NA	DK	Not Obs	% #	Citation	Required Corrective Action Evidence of Change	Timelines and Resources	Closed Date
						<b>Topical Area 1: Policies, Practices, and Procedures</b>			
Y						1. <b>FSA-ASSISTIVE TECHNOLOGY AND SERVICES</b>  <b>Standard:</b> The Local Education Agency (LEA) observed the requirement that the provision of assistive technology is reflected in the student's IEP			
Y						1A. <b>FSA-HEARING AIDS</b>  <b>Standard:</b> Each public agency shall ensure that the hearing aids worn in school by children with hearing impairments, including deafness, are functioning properly. Each public agency must ensure that the external components of surgically implanted medical devices are functioning properly			
Y						2. <b>FSA-POSITIVE BEHAVIOR SUPPORT</b>  <b>Standard:</b> LEA complies with the positive behavior support policy requirements.			
Y						3. <b>FSA-CHILD FIND</b>  <b>Standard:</b> LEA demonstrates compliance with annual public notice requirements.			



Y	N	NA	DK	Not Obs	% #	Citation	Required Corrective Action Evidence of Change	Timelines and Resources	Closed Date
Y						4. <b>FSA-CONFIDENTIALITY</b>  Standard The LEA is in compliance with confidentiality requirements.			
		X				5. <b>FSA-DISPUTE RESOLUTION (DUE PROCESS HEARING DECISION IMPLEMENTATION)</b>  Standard: The LEA uses dispute resolution processes for program improvement.			
		X				8. <b>FSA-PROCEDURAL REQUIREMENTS FOR SUSPENSION</b>  Standard: The LEA adheres to procedural requirements in suspending students with disabilities.			
Y						10. <b>FSA-INDEPENDENT EDUCATIONAL EVALUATION</b>  Standard: The LEA documents a procedure for responding to requests made by parents for an independent educational evaluation at public expense.			
Y						11A. <b>FSA-LEAST RESTRICTIVE ENVIRONMENT</b>  Standard: The LEA's continuum of special education services supports the availability of LRE under 34 CFR Part 300.			
Y						12. <b>FSA-EXTENDED SCHOOL YEAR SERVICES</b>			
Y						13. <b>FSA-RELATED SERVICE INCLUDING PSYCHOLOGICAL COUNSELING</b>			
Y						15. <b>FSA-PARENT TRAINING</b>  Standard: Parent opportunities for training and information sharing address the special knowledge, skills and abilities needed to serve the unique needs of children with disabilities.			
						<b>INTERVIEW RESULTS (Parent)</b>			
						P 62. My school district/charter school makes available training related to the needs of students with disabilities that I could attend.			

Y	N	NA	D K	Not Obs	% #	Citation	Required Corrective Action Evidence of Change	Timelines and Resources	Closed Date
					4 0 0 2 0 0	Always Sometimes Rarely Never Don't Know Does not Apply			
					4 0 0 2 0 0	P 63. My school district/charter school invites parents to trainings that are available to school staff regarding research based best practices, supplementary aids and services, differentiating instruction and modifying the general education curriculum.  Always Sometimes Rarely Never Don't Know Does not Apply			
Y						18. <b>FSA-SURROGATE PARENTS (STUDENTS REQUIRING)</b>  <b>Standard:</b> The LEA identifies eligible students in need of surrogate parents and recruits, selects, trains, and assigns in a timely manner.			
Y						19. <b>FSA-PERSONNEL TRAINING</b>  <b>Standard:</b> In-service training appropriately and adequately prepares and trains personnel to address the special knowledge, skills, and abilities to serve the unique needs of children with disabilities, including those with low incidence disabilities, when applicable.			
						<b>INTERVIEW RESULTS (General &amp; Special Education Teacher)</b>			
6	0	0				GE 88. Do you receive training regarding how to differentiate instruction and modify the curriculum in your classroom?			
5	0	1				GE 89. Do you receive training regarding how to provide positive behavior supports for students with negative behaviors?			
2	0	4				GE 90. If you have a student with a behavioral need, have you been trained how to deescalate negative and aggressive student behavior?			
6	0	0				GE 91. Do you participate in determining the kinds of training and technical assistance needed to support students with IEPs in regular education classrooms?			

Y	N	NA	DK	Not Obs	% #	Citation	Required Corrective Action Evidence of Change	Timelines and Resources	Closed Date
1	0	5				GE 94. If a student has AT included in his/her current IEP, have you received training in AT, and accessing AT resources?			
8	1	1				SE 124. Do you collaborate with general education teachers and administrators to recommend training needs for personnel within the LEA?			
		X				20. <b>FSA-INTENSIVE INTERAGENCY APPROACH</b>  <b>Standard:</b> The LEA identifies, reports, and provides for the provision of Free Appropriate Public Education (FAPE) for all students with disabilities including those students needing intensive interagency approaches.			
Y						21. <b>FSA-SUMMARY OF ACADEMIC AND FUNCTIONAL PERFORMANCE/PROCEDURAL SAFEGUARD REQUIREMENTS FOR GRADUATION</b>  <b>Standard:</b> The LEA provides Summary of Academic Achievement and Functional Performance for children whose eligibility terminates due to graduation or aging out. The LEA provides required prior written notice for graduation			
	N					21A. <b>TRANSITION REQUIREMENTS</b>  <b>Standard:</b> The LEA complies with requirements for transition planning for students.	The LEA has been provided with the names of individual students for whom corrective action is required.		
						<b>Topical Area 2: Delivery of Service</b>			
Y						17. <b>FSA-PUBLIC SCHOOL ENROLLMENT</b>  <b>Standard:</b> The LEA's percentage of children with disabilities served in special education is comparable to state data.			
Y						17B. <b>FSA-PUBLIC SCHOOL ENROLLMENT</b>  <b>Standard:</b> Timely provision of FAPE for students who transfer public agencies within state, and from another state.			

Y	N	NA	DK	Not Obs	% #	Citation	Required Corrective Action Evidence of Change	Timelines and Resources	Closed Date
Y						22. <b>FSA-DISPROPORTIONATE REPRESENTATION THAT IS THE RESULT OF INAPPROPRIATE IDENTIFICATION</b>  <b>Standard:</b> LEA does not demonstrate disproportionate representation of racial/ethnic groups receiving special education or by disability group.			
Y						23. <b>FSA-EDUCATIONAL BENEFIT REVIEW</b>  <b>Standard:</b> The IEP meets procedural compliance and is reasonably calculated to enable the child to advance appropriately toward attaining their annual goals.			
						<b>CLASSROOM OBSERVATIONS</b>			
0	0	0		0		CO 1. Is the instruction provided to the student individualized as required by his/her IEP?			
0	0	0		0		CO 2. Is the instruction being provided in accordance with the goals in the student's IEP?			
0	0	0		0		CO 3. If assistive technology is included in the student's IEP and required for the activity observed, is it being used?			
0	0	0		0		CO 4. If the student is in a regular education setting, is he/she participating in the lesson taught by the general education teacher or a co-teacher?			
0	0	0		0		CO 5. If the student is in a regular education setting, is the student appropriately integrated (physically) in the class?			
0	0	0		0		CO 6. If the student's IEP contains supplementary aids and/or services, are they being delivered in the classroom setting as required?			
0	0	0		0		CO 7. Does this setting coincide with the student's IEP with regard to the extent to which the student is educated with non-disabled peers?			
						<b>INTERVIEW RESULTS (Parent, General &amp; Special Education Teacher)</b>			
						P 55. My child does classroom work in a regular classroom with students without disabilities.			
					3	Always			
					1	Sometimes			
					0	Rarely			
					1	Never			
					1	Don't Know			
					0	Does not Apply			

Y	N	NA	D K	Not Obs	% #	Citation	Required Corrective Action Evidence of Change	Timelines and Resources	Closed Date
					4 1 0 1 0 0	P 56. My child participates or has the opportunity to participate in school activities other than classroom work, including extra-curricular activities, with students without disabilities.  Always Sometimes Rarely Never Don't Know Does not Apply			
					2 3 0 1 0 0	P 56a. My child goes on field trips, attends school functions and/or participates in extracurricular activities with their same age/grade peers who are non-disabled.  Always Sometimes Rarely Never Don't Know Does not Apply			
					3 1 0 1 1 0	P 56b. There are routine opportunities for my child to interact with peers who are non-disabled that are planned and/or facilitated by school personnel.  Always Sometimes Rarely Never Don't Know Does not Apply			
6	0	0				GE 70. Are you familiar with the content of this student's current IEP, including accommodations, supplementary aids and services, and annual goals?			
6	0	0				GE 71. Do you adapt and modify the general education curriculum based on the student's current IEP?			
6	0	0				GE 72. Do you have support from special education personnel to help you modify curriculum, instruction and assessment as required in the student's current IEP?			
6	0	0				GE 73. Are you and the special education personnel working collaboratively to implement this student's program?			
6	0	0				GE 78. Are all the supplementary aids and services necessary for the student's progress in the general education class included in his/her current IEP?			
6	0	0				GE 80. Is the student making progress within the general education curriculum?			

Y	N	NA	DK	Not Obs	% #	Citation	Required Corrective Action Evidence of Change	Timelines and Resources	Closed Date
6	0	0				GE 80a. In your opinion, is this student benefiting from participation in your general education classroom?			
0	0	0				GE 80b. If yes, in what ways? Doing better, engaging with peer groups. Enjoys the curriculum, doing a great job with the work assigned. Enjoying the curriculum and doing a great job with it. Interacts with peers, building confidence. Opportunity to work in large and small settings. Getting good grades, completing work.			
0	0	6				GE 80c. If no, what does this student need that he/she is not receiving in your class?			
6	0	0				GE 85. Do you have sufficient time to collaborate with the special education teacher in order to meet this student's needs?			
6	0	0				GE 85a. Have you received sufficient training, technical assistance and other support to teach this student?			
0	0	6				GE 85b. If no, what training or support would assist you?			
6	0	0				GE 93. Do special education personnel work directly with you to help you reduce negative student behaviors?			
10	0	0				SE 95. Is this student participating in the general education class and curriculum with students without disabilities to the maximum extent possible?			
8	0	2				SE 95a. In the most recent IEP meeting for this student, did you discuss whether he/she could be educated in a general education classroom for the entire school day?			
8	0	2				SE 95b. In the most recent IEP meeting, did the IEP team recommend removal of this student from the general education classroom for any part of the school day?			
0	0	2				SE 95c. If yes, what reasons were discussed for recommending removal? Needed help in some core subjects. The need for more support. Needed extra help. Needed more support and service. Needs Needed more services. Needs require more support and service. Due to needs.			
0	0	2				SE 95d. If yes, how was the amount of time that this student would be removed from the general education classroom decided?			

Y	N	NA	DK	Not Obs	% #	Citation	Required Corrective Action Evidence of Change	Timelines and Resources	Closed Date
						Specific times during the day on regular schedule. IEP team. IEP team. IEP team. Needs additional supports and services. Based on specific classes that were needed. Team Needed more service and support.			
7	0	3				SE 95e. In the most recent IEP meeting, did the IEP team discuss whether this student could be educated satisfactorily in a general education classroom for the entire school day with supplementary aids and services?			
10	0	0				SE 96. Has the student been given the opportunity to participate in non-academic and extracurricular activities with children without disabilities?			
7	0	3				SE 97. Have necessary supports been offered and/or provided to enable that participation?			
10	0	0				SE 99. Are you and related services personnel working together toward meeting the measurable annual goals for this student?			
9	0	1				SE 100. Are you and general education personnel working together toward meeting the measurable annual goals for this student?			
6	3	1				SE 115. Did the IEP team have available information regarding use of the Supplementary Aids and Services ToolKit?			
8	1	1				SE 125. Do you collaborate with general education teachers to identify training needs related to the provision of supplementary aids and services to students with IEPs in the general education classroom?			
						<b>Topical Area 3: Performance Indicators</b>			
		X				5A. <b>FSA-EFFECTIVE USE OF DISPUTE RESOLUTION</b>  Standard: The LEA uses dispute resolution processes for program improvement.			
	N					6. <b>FSA-GRADUATION RATES (SPP)</b>  Standard: The graduation rate of the LEA's students with disabilities is comparable to the state graduation rate.	The LEA will develop an improvement plan to address meeting the SPP target for graduation rates.		

Y	N	NA	DK	Not Obs	% #	Citation	Required Corrective Action Evidence of Change	Timelines and Resources	Closed Date
	N					7. <b>FSA-DROPOUT RATES (SPP)</b>  <b>Standard:</b> The dropout rate of the LEA's students with disabilities is comparable to the state dropout rate.	The LEA will develop an improvement plan to address meeting the SPP target for drop out rates.		
		X				8A. <b>FSA-SUSPENSION RATES</b>  <b>Standard:</b> The LEA's rate of suspensions and expulsions of students with disabilities is comparable to the rate of other LEAs in the state.			
	N					11. <b>FSA-LEAST RESTRICTIVE ENVIRONMENT (SPP)</b>  <b>Standard:</b> Students with disabilities are provided for in the least restrictive environment	The LEA will develop an improvement plan to address meeting the SPP target for students with disabilities served inside the regular classroom less than 40% of the day.		
	N					16. <b>FSA-PARTICIPATION IN PSSA AND PASA (SPP)</b>  <b>Standard:</b> The LEA's population of students who participate in state assessment is comparable with the state data.	The LEA will develop an improvement plan to address meeting the SPP target to increase participation rate in state and local assessments.		
Y						16A. <b>FSA-LOCAL ASSESSMENT</b>			
						<b>Topical Area 4: Evaluation and Reevaluation Process and Content</b>			
						<b>CONSENT AND WAIVER REQUIREMENTS FOR EVALUATION/REEVALUATION</b>			
						<b>PERMISSION TO EVALUATE (File Reviews)</b>			
1	0	9				FR 153. PTE-Consent Form is present in the student file			
1	0	9				FR 154. Demographic data			
1	0	9				FR 155. Reason(s) for referral for evaluation			
1	0	9				FR 156. Proposed types of tests and assessments			
1	0	9				FR 157. Contact person's name and contact information			
1	0	9				FR 158. Parent signature or documentation of reasonable efforts to obtain consent			
1	0	9				FR 159. Parent has selected a consent option			
						<b>PERMISSION TO REEVALUATE (File Reviews)</b>			
4	1	5			20%	FR 194. PTRE-Consent Form is present in the student file			
4	0	6				FR 195. Demographic data			
4	0	6				FR 196. Reason for reevaluation			
4	0	6				FR 197. Types of assessment tools, tests and procedures to be used			
4	0	6				FR 198. Contact person's name and contact information			



Y	N	NA	D K	Not Obs	% #	Citation	Required Corrective Action Evidence of Change	Timelines and Resources	Closed Date
4	0	6				FR 199. Parent has selected a consent option			
4	0	6				FR 200. Parent signature or documentation of reasonable efforts to obtain consent			
						<b>AGREEMENT TO WAIVE REEVALUATION (File Reviews)</b>			
0	0	10				FR 201. Agreement to Waive Recvaluation is present in the student file			
0	0	10				FR 202. Waiver was completed within required timelines (3 years (2 years for any ID student or any student placed in an Approved Private School) from date of ER, prior RR, or Agreement to Waive RR)			
0	0	10				FR 203. Reason reevaluation is not necessary at this time is included			
0	0	10				FR 204. Contact person's name and contact information			
0	0	10				FR 205. Parent has selected a consent option			
0	0	10				FR 206. Parent signature			
						<b>EVALUATION REPORT (INITIAL) (File Reviews)</b>			
1	0	9				FR 160. ER is present in the student file			
0	1	9			100%	FR 161. Evaluation was completed within timelines			
1	0	9				FR 162. A copy of the ER was disseminated to parents at least 10 school days prior to meeting of the IEP team (unless this requirement is waived by parent in writing)			
1	0	9				FR 163. Demographic data			
1	0	9				FR 164. Date report was provided to parent			
1	0	9				FR 165. Reason(s) for referral			
1	0	9				FR 166. Reason(s) for referral reflect the reason(s) listed on the PTE-Consent Form			
1	0	9				FR 167. Evaluations and information provided by the parents of the student (or documentation of LEA's attempts to obtain parent input)			
1	0	9				FR 168. Teacher observations and observations by related service providers, when appropriate			
1	0	9				FR 169. Recommendations by teachers			
1	0	9				FR 170. The student's physical condition (including health, vision, hearing); social or cultural background; and adaptive behavior relevant to the student's suspected disability and potential need for special education			

Y	N	NA	DK	Not Obs	% #	Citation	Required Corrective Action Evidence of Change	Timelines and Resources	Closed Date
1	0	9				FR 171. Assessments, including when appropriate, current classroom based assessments, aptitude and achievement tests; local and/or state assessments; behavioral assessments; vocational technical education assessment results; interests, preferences, aptitudes (for secondary transition); etc.			
0	0	10				FR 172. If an assessment is not conducted under standard conditions, description of the extent to which it varied from standard conditions (including if the assessment was given in the student's native language or other mode of communication)			
1	0	9				FR 173. Lack of appropriate instruction in reading			
1	0	9				FR 174. Lack of appropriate instruction in math			
1	0	9				FR 175. Limited English proficiency			
1	0	9				FR 176. Present levels of academic achievement			
1	0	9				FR 177. Present levels of functional performance			
1	0	9				FR 178. Behavioral information			
1	0	9				FR 179. Conclusions			
1	0	9				FR 180. Disability Category			
1	0	9				FR 181. Recommendations for consideration by the IEP team			
1	0	9				FR 182. Evaluation Team Participants documented			
0	0	10				FR 183. For students evaluated for SLD documentation of Agree/Disagree			
0	0	10				FR 184. Documentation that the student does not achieve adequately for age, etc.			
0	0	10				FR 185. Indication of process(es) used to determine eligibility			
0	0	10				FR 186. Instructional strategies used and student-centered data collected			
0	0	10				FR 187. Educationally relevant medical findings, if any			
0	0	10				FR 188. Effects of the student's environment, culture, or economic background			
0	0	10				FR 189. Data demonstrating that regular education instruction was delivered by qualified personnel, including the ESL program, if applicable			
0	0	10				FR 190. Data based documentation of repeated assessments of achievement at reasonable intervals, which was provided to parents			
0	0	10				FR 191. Observation in the student's learning environment			
0	0	10				FR 192. Other data if needed			

Y	N	NA	D K	Not Obs	% #	Citation	Required Corrective Action Evidence of Change	Timelines and Resources	Closed Date
0	0	10				FR 193. Statement for all 6 items indicated to support conclusions of the evaluation team			
						<b>REEVALUATION REPORT (File Reviews)</b>			
9	0	1				FR 207. RR is present in the student file			
9	0	1				FR 208. Reevaluation was completed within timelines (either 60 calendar days from the date of LEA receipt of signed PTRE-Consent Form, excluding summer break, or within 3 years (2 years for any ID student or any student placed in an Approved Private School) of date of ER, prior RR, or Agreement to Waive RR)			
9	0	1				FR 209. A copy of the RR was disseminated to parents at least 10 school days prior to the meeting of the IEP team (unless this requirement was waived by a parent in writing)			
9	0	1				FR 210. Demographic data			
9	0	1				FR 211. Date IEP team reviewed existing evaluation data			
9	0	1				FR 212. Physical condition, social, or cultural background and adaptive behavior relevant to the student's need for special education			
9	0	1				FR 213. Evaluations and information provided by the parent (or documentation of LEA's attempts to obtain parent input)			
9	0	1				FR 214. Aptitude and achievement tests			
9	0	1				FR 215. Current classroom based assessments and local and/or state assessments			
9	0	1				FR 216. Observations by teacher(s) and related service provider(s) when appropriate			
9	0	1				FR 217. Teacher recommendations			
9	0	1				FR 218. Lack of appropriate instruction in reading			
9	0	1				FR 219. Lack of appropriate instruction in math			
9	0	1				FR 220. Limited English proficiency			
9	0	1				FR 221. Conclusion regarding need for additional data is indicated			
5	0	5				FR 222. Reasons additional data are not needed are included			
9	0	1				FR 223. Determination whether the child has a disability and requires special education			
9	0	1				FR 224. Disability category(ies)			
9	0	1				FR 225. Summary of findings includes student's educational strengths and needs			

Y	N	NA	DK	Not Obs	% #	Citation	Required Corrective Action Evidence of Change	Timelines and Resources	Closed Date
9	0	1				FR 226. Summary of findings includes present levels of academic achievement and related developmental needs, including transition needs as appropriate			
9	0	1				FR 227. Summary of findings includes recommendations for consideration by the IEP team regarding additions or modifications to the student's programs			
3	1	6			25%	FR 228. Interpretation of additional data			
0	0	10				FR 229. Documentation that the student does not achieve adequately for age, etc.			
0	0	10				FR 230. Indication of process(es) used to determine eligibility			
0	0	10				FR 231. Instructional strategies used and student-centered data collected			
0	0	10				FR 232. Educationally relevant medical findings, if any			
0	0	10				FR 233. Effects of the student's environment, culture, or economic background			
0	0	10				FR 234. Data demonstrating that regular education instruction was delivered by qualified personnel, including the ESL program, if applicable			
0	0	10				FR 235. Data based documentation of repeated assessments of achievement at reasonable intervals, which was provided to parents			
0	0	10				FR 236. Observation in the student's learning environment			
0	0	10				FR 237. Other data if needed			
0	0	10				FR 238. Statement for all 6 items			
9	0	1				FR 239. Documentation of Evaluation Team Participants			
0	0	10				FR 240. Documentation that team members Agree/Disagree			
						<b>INTERVIEW RESULTS (Parent &amp; Special Education Teacher)</b>			
5	1	0	0			P 24. Have you been asked to provide information for your child's evaluation/reevaluation?			
5	0	1	0			P 25. Were you given the opportunity to provide this information in writing or in another way that worked for you?			
5	0	1	0			P 26. Was the information you provided to the school for your child's evaluation considered in your child's Evaluation Report?			

Y	N	NA	DK	Not Obs	% #	Citation	Required Corrective Action Evidence of Change	Timelines and Resources	Closed Date
2	0	4	0			P 27. If your child was not reevaluated when required (every 2 years for children with intellectual disability (consent retardation), or any child placed in an Approved Private School, and every 3 years for children with other disabilities) did you agree in writing to waive the reevaluation?			
0	4	2	0			P 51. Have you requested an Independent Educational Evaluation (IEE) for your child to be paid for by the school?			
0	0	6	0			P 52. If you have obtained an IEE for your child, were the results of that evaluation considered by the team?			
0	0	6	0			P 53. Were the results of the IEE included in the school's Evaluation Report for your child?			
5	0	5				SE 119. If this student is not making progress, has he/she been reevaluated and/or has the IEP been reviewed?			
						<b>Topical Area 5: IEP Process and Content</b>			
						<b>INVITATION TO PARTICIPATE IN IEP TEAM OR OTHER MEETING (File Reviews)</b>			
10	0	0				FR 241. Invitation is present in the student file			
10	0	0				FR 242. Invitation to Participate in the IEP Meeting was issued prior to the meeting (or documentation that parent signed waiver to move directly to IEP meeting)			
9	1	0			10%	FR 243. Demographic data			
10	0	0				FR 244. Purpose(s) of the meeting			
6	0	4				FR 245. Transition planning and services – Invitation to parents is checked (age 14, younger if determined appropriate)			
6	0	4				FR 246. Transition planning and services - if appropriate, evidence that a representative of any participating agency was invited to the IEP team meeting with the prior consent of the parent or student			
6	0	4				FR 247. Transition planning and services – Invitation to student is checked (age 14, or younger if determined appropriate)			
10	0	0				FR 248. Invited IEP team members			
10	0	0				FR 249. Date/time/location of meeting			
10	0	0				FR 250. Parent response, or documentation of parent attendance at the meeting, or documentation of multiple efforts to encourage participation			
						<b>PARENT CONSENT TO EXCUSE MEMBERS FROM ATTENDING IEP TEAM MEETING (File Reviews)</b>			

Y	N	NA	DK	Not Obs	% #	Citation	Required Corrective Action Evidence of Change	Timelines and Resources	Closed Date
1	0	9				FR 251. Parent Consent to Excuse Members from Attending the IEP Team Meeting is present in the student file			
1	0	9				FR 252. Demographic data			
1	0	9				FR 253. Form designates required IEP team member(s) for whom attendance is not necessary			
1	0	9				FR 254. Form designates which members will submit written input prior to the meeting			
1	0	9				FR 255. Parent written consent is documented			
					0	FR 256. The team members excused:			
					1	a. General Education Teacher			
					0	b. Special Education Teacher			
						c. Local Education Agency Representative			
						<b>IEP CONTENT (File Reviews)</b>			
10	0	0				FR 257. IEP is present in the student file			
10	0	0				FR 258. IEP was completed within timelines			
10	0	0				FR 259. Demographic data			
10	0	0				FR 260. IEP implementation date			
10	0	0				FR 261. Anticipated duration of services and programs			
3	0	7				FR 262. If appropriate, LEA and parent agreement to make changes to IEP without convening an IEP meeting			
						<b>DOCUMENTATION OF IEP TEAM PARTICIPATION (File Reviews)</b>			
10	0	0				FR 263. Parents			
6	0	4				FR 264. Student			
10	0	0				FR 265. General Education Teacher			
10	0	0				FR 266. Special Education Teacher			
9	0	1				FR 267. Local Education Agency Representative			
1	0	9				FR 270. Community Agency Representative			
0	0	10				FR 271. Teacher of the Gifted			
1	0	9				FR 272. Written input provided by IEP team member(s) excused from participating in the IEP meeting if the invitation stated they were to provide written input			
9	1	0			10%	FR 273. Copy of Procedural Safeguards Notice was given to parent during the school year			
						<b>SPECIAL CONSIDERATIONS (File Reviews)</b>			
0	0	10				FR 274. If the student is blind or visually impaired, a description of the instruction in Braille and the use of Braille, unless the IEP team determines that such instruction is not appropriate			

Y	N	NA	DK	Not Obs	% #	Citation	Required Corrective Action Evidence of Change	Timelines and Resources	Closed Date
0	0	10				FR 275. If the student is deaf or hard of hearing, a communication plan			
3	0	7				FR 276. If the student has communication needs, needs must be addressed in the IEP			
0	0	10				FR 277. If the student requires assistive technology devices and/or services, needs must be addressed in the IEP			
0	0	10				FR 278. If the student has limited English proficiency, the IEP team must consider English as Second Language for provision of FAPE			
3	0	7				FR 279. If the student has behaviors that impede his/her learning or that of others, the IEP includes a Positive Behavior Support Plan based on a functional assessment of behavior utilizing positive behavior techniques			
3	0	7				FR 280. If the student has other special considerations, these are addressed in the IEP			
						<b>PRESENT LEVELS OF ACADEMIC ACHIEVEMENT AND FUNCTIONAL PERFORMANCE (File Reviews)</b>			
10	0	0				FR 281. Student's present levels of academic achievement			
10	0	0				FR 282. Student's present levels of functional performance			
6	0	4				FR 283. Present levels related to current postsecondary transition goals (if student is 14, or younger if determined by IEP team)			
9	0	1				FR 284. Parental concerns for enhancing the education of the student (if provided by parent to the LEA)			
10	0	0				FR 285. How the student's disability affects involvement and progress in the general education curriculum			
10	0	0				FR 286. Strengths			
10	0	0				FR 287. Academic, developmental, and functional needs related to student's disability			
						<b>TRANSITION SERVICES (File Reviews)</b>			
6	0	4				FR 289. Evidence that the measurable postsecondary goal(s) were based on age appropriate transition assessment			
6	0	4				FR 290. An appropriate measurable postsecondary goal or goals that covers education or training, employment, and, as needed, independent living			
6	0	4				FR 291. Evidence that the postsecondary goal or goals that covers education or training, employment, and, as needed, independent living are updated annually			

Y	N	NA	DK	Not Obs	% #	Citation	Required Corrective Action Evidence of Change	Timelines and Resources	Closed Date
6	0	4				FR 292. Location, Frequency, Projected Beginning Date, Anticipated Duration, and Person(s)/Agency Responsible for Activity/Service			
6	0	4				FR 292a. Transition services include courses of study that will reasonably enable the student to meet his/her postsecondary goal(s)			
6	0	4				FR 292b. Transition services in the IEP that will reasonably enable the student to meet his/her postsecondary goal(s)			
6	0	4				FR 292c. Annual goals are related to the student's transition services			
						<b>PARTICIPATION IN STATE AND LOCAL ASSESSMENTS (File Review)</b>			
8	0	2				FR 293. Documentation of IEP team decision regarding participation in statewide assessments (PSSA/Keystone Exams, ACCESS for ELLS, Alternate ACCESS for ELLS or PASA)			
4	0	6				FR 294. If the student will participate in the PSSA, documentation of IEP team decision regarding participation with or without accommodations			
4	0	6				FR 295. If the student will participate in the PASA, an explanation of why the student cannot participate in the PSSA/Keystone Exams			
3	0	7				FR 296. If the student will participate in the PASA, explanation of why PASA is appropriate			
3	0	7				FR 297. If the student will participate in the PASA, how student's performance will be documented (videotape or written narrative)			
10	0	0				FR 298. Indication of IEP team decision regarding participation in local assessments (local or alternate local)			
8	0	2				FR 299. If the student will participate in local assessments, indication of IEP team decision regarding participation with or without accommodations			
3	0	7				FR 300. If the IEP indicates the student will participate in an alternate local assessment, explanation of why the student cannot participate in the regular assessment			
3	0	7				FR 301. If the student will participate in an alternate local assessment, explanation of why the alternate assessment is appropriate			
						<b>ANNUAL GOALS AND OBJECTIVES (INCLUDING ACADEMIC AND FUNCTIONAL GOALS) (File Reviews)</b>			
10	0	0				FR 302. Measurable Annual Goals			



Y	N	NA	D K	Not Obs	% #	Citation	Required Corrective Action Evidence of Change	Timelines and Resources	Closed Date
10	0	0				FR 303. Description of how student progress toward meeting goals will be measured			
10	0	0				FR 304. Description of when periodic reports on progress will be provided to parents			
10	0	0				FR 305. Documentation of progress reporting on Annual Goals			
5	0	5				FR 306. Short Term Objectives			
						<b>SPECIAL EDUCATION/RELATED SERVICES/SUPPLEMENTARY AIDS AND SERVICES/PROGRAMS MODIFICATIONS (File Reviews)</b>			
10	0	0				FR 307. Program Modifications and Specially-Designed Instruction			
10	0	0				FR 308. If the student's most recent Evaluation Report contained recommendations for modifications and accommodations, did the IEP team address those recommendations in development of this IEP			
10	0	0				FR 309. If Program Modifications and Specially Designed Instruction are included on the IEP, the location, frequency, projected beginning date and anticipated duration of services			
0	0	10				FR 310. If a student attends a Career or Vocational Technical School, evidence that the specially designed instruction addresses the student's needs in Career and Vocational Technical School			
9	0	1				FR 311. If Related Services are included on the IEP, the location, frequency, projected beginning date and anticipated duration of services			
9	0	1				FR 312. If the student's most recent Evaluation Report contained recommendations for the provision of related services, including psychological counseling, did the IEP team address those recommendations in development of this IEP			
10	0	0				FR 313. If Supports for school personnel are included on the IEP, the personnel to receive support, support, location, frequency, projected beginning date and anticipated duration of services			
10	0	0				FR 314. If the student's most recent Evaluation Report contained recommendations for program modifications or supports for school personnel provided for the student, did the IEP team address those recommendations in development of this IEP			
0	0	10				FR 315. Support services, if the student is identified as gifted and also is identified as a student with a disability			

Y	N	NA	DK	Not Obs	% #	Citation	Required Corrective Action Evidence of Change	Timelines and Resources	Closed Date
10	0	0				FR 316. A conclusion regarding student eligibility for ESY			
10	0	0				FR 317. Information or data reviewed by the IEP team to support the ESY eligibility determination			
3	0	7				FR 318. Where ESY services were deemed appropriate, annual goals and when appropriate, short term objectives that are to be addressed in the child's ESY program			
3	0	7				FR 319. Where ESY was determined to be appropriate, ESY service to be provided, location, frequency, projected beginning date and anticipated duration of services			
						<b>EDUCATIONAL PLACEMENT (File Reviews)</b>			
10	0	0				FR 320. Explanation of the extent, if any, to which the student will not participate with students without disabilities in the regular education class			
10	0	0				FR 321. Explanation of the extent, if any, to which the student will not participate with students without disabilities in the general education curriculum			
10	0	0				FR 322. Type of support, by amount (itinerant, supplemental, full-time)			
10	0	0				FR 323. Type of special education supports, e.g. autistic support, emotional support, learning support, etc.			
10	0	0				FR 324. Location of student's program (name of LEA where the IEP will be implemented)			
10	0	0				FR 325. Location of student's program (name of School Building where the IEP will be implemented)			
2	0	8				FR 326. If child will not be attending his/her neighborhood school, reason why not			
						<b>PENNDATA REPORTING FOR EDUCATIONAL ENVIRONMENT (File Reviews)</b>			
10	0	0				FR 327. Completed Section A or Section B			
						<b>IEP DEVELOPMENT</b>			
						<b>INTERVIEW RESULTS (Parent &amp; General Education Teacher)</b>			
6	0	0	0			P 28. Were you invited to participate in your child's most recent IEP team meeting?			
6	0	0	0			P 29. Did you participate in developing the current IEP for your child?			
6	0	0	0			P 30. Was the meeting held at a time and location that was convenient for you?			
2	0	4	0			P 31. If you were unable to participate in person, did the school offer other arrangements for you to participate by phone or through other methods?			

Y	N	NA	DK	Not Obs	% #	Citation	Required Corrective Action Evidence of Change	Timelines and Resources	Closed Date
5	1	0	0			P 32. Was the input you provided considered in the development of your child's current IEP?			
4	1	1	0			P 32a. Have you received sufficient training, technical assistance and other support to participate as an IEP team member?			
0	0	5	0			P 32b. If no, what training or support would assist you? Need more information about my child's disability category and needs.			
4	0	2	0			P 33. Were the services you requested for your child considered by the IEP team in the development of your child's current IEP?			
6	0	0	0			P 35. Was the current IEP developed at the IEP meeting?			
6	0	0	0			P 36. If there was a draft IEP developed prior to the IEP meeting were you provided a copy of the draft either before or at the meeting?			
6	0	0	0			P 37. Were the special education teacher, the general education teacher and the school representative at the IEP meeting?			
0	0	6	0			P 38. If required IEP team members (special education teacher, general education teacher, or LEA) did not attend the meeting, did you agree in writing to them not being there?			
0	0	6	0			P 39. Was written input from the excused IEP team member(s) available to you before the meeting?			
		5	0		1	P 65. If you did not participate in your child's IEP meeting, what kept you from participating? g. other Appointment			
4	0	2				GE 74. Did you attend the most recent IEP meeting for this student or have the opportunity to provide input?			
3	1	2				GE 75. Did you recommend any needed supports to implement the current IEP for this student?			
3	0	3				GE 76. Were those recommendations considered by the IEP team?			
6	0	0				GE 86. When a student with a disability is included in your class do you have the opportunity to provide information to the IEP team?			
3	3	0				GE 87. Do you provide progress monitoring data as part of the IEP development process?			
						<b>IEP CONTENT</b>			
						<b>INTERVIEW RESULTS (Parent, General &amp; Special Education Teacher)</b>			

Y	N	NA	DK	Not Obs	% #	Citation	Required Corrective Action Evidence of Change	Timelines and Resources	Closed Date
6	0	0	0			P 40. Did the IEP team consider the recommendations that were made in your child's most recent evaluation, including all recommendations that were made by the evaluation team for special education, related services, and supports for school personnel?			
6	0	0	0			P 41. Did the IEP team accept or reject the evaluation team's recommendations for special education, related services, and supports for school personnel for appropriate educational reasons.			
6	0	0				GE 81. Are this student's goals based on the PA Standards/PA Common Core or, if appropriate, alternate standards?			
6	0	0				GE 82. Is the specially designed instruction in this student's current IEP appropriate to meet his/her educational needs?			
6	0	0				GE 83. Is the current IEP appropriate to meet this student's educational needs?			
10	0	0				SE 98. Unless otherwise specified in the student's IEP, is the length of this student's instructional day the same as nondisabled students?			
10	0	0				SE 102. Is the specially-designed instruction in the current IEP appropriate to meet this student's educational needs?			
10	0	0				SE 103. Are the student's annual goals based on the PA Standards/PA Common Core or, if appropriate, alternate standards?			
6	0	4				SE 104. If appropriate, are the student's annual goals based on functional performance?			
10	0	0				SE 106. If the student's most recent Evaluation Report contained recommendations for modifications and accommodations did the IEP team address those recommendations in development of the student's current IEP and accept or reject the ER recommendations for appropriate educational reasons?			
10	0	0				SE 107. If the student's most recent Evaluation Report contained recommendations for provision of related services, including psychological counseling, did the IEP team address those recommendations in development of the student's current IEP and accept or reject the ER recommendations for appropriate educational reasons?			

Y	N	NA	D K	Not Obs	% #	Citation	Required Corrective Action Evidence of Change	Timelines and Resources	Closed Date
10	0	0				SE 108. If the student's most recent Evaluation Report contained recommendations for program modifications or supports for school personnel that will be provided for the student, did the IEP team address those recommendations in development of the student's current IEP and accept or reject the ER recommendations for appropriate educational reasons?			
8	0	2				SE 112. Was it an IEP team decision as to whether this student would participate in the PSSA/Keystone Exams, PASA, and other district-wide/charter school-wide assessments?			
10	0	0				SE 117. Is this student making progress in meeting the annual goals of his/her current IEP?			
8	0	2				SE 117a. In your opinion, is this student benefiting from participation in the general education classroom?			
0	0	2				SE 117b. If yes, in what ways? Grades have improved, socially interacting more. Making good grades, gaining skills. Class participation, positive interactions with peers. Working with peers and making contribution in class. Working with peers and making contribution in class. Has made great leaps in progress. Able to model learning styles and team work with others. Likes being with peers.			
0	0	10				SE 117c. If no, what does this student need that he/she is not receiving?			
10	0	0				SE 118. Is the progress on annual goals recorded and reported to the parent based on objective and measurable data?			
						<b>IEP IMPLEMENTATION</b>			
						<b>INTERVIEW RESULTS (Parent, General &amp; Special Education Teacher)</b>			
6	0	0	0			P 48. Were the special education and related services in your child's current IEP provided within 10 school days of the completion of the IEP?			
6	0	0	0			P 49. Are the special education and related services included in your child's current IEP provided at no cost to you?			
						P 57. When all students in the school receive a report card, I also receive a progress report on my child's IEP goals.			

Y	N	NA	DK	Not Obs	% #	Citation	Required Corrective Action Evidence of Change	Timelines and Resources	Closed Date
					4 0 0 1 1 0	Always Sometimes Rarely Never Don't Know Does not Apply			
					5 0 0 1 0 0	P 58. My child's progress is reported to me by the school in a manner that I understand. Always Sometimes Rarely Never Don't Know Does not Apply			
6	0	0	0			P 64. My child is receiving the supports and services agreed upon at the IEP meeting.			
6	0	0				GE 77. If supports for school personnel are included in the student's current IEP, has the LEA provided those supports?			
6	0	0				GE 79. Are the supplementary aids and services, including program modifications and specially designed instruction in the student's current IEP, being provided?			
4	0	2				GE 79a. In the most recent IEP meeting for this student, did you discuss whether the student could be educated in a general education classroom for the entire school day?			
3	1	2				GE 79b. In the most recent IEP meeting, did the IEP team recommend removal of this student from the general education classroom for any part of the school day?			
0	0	3				GE 79c. If yes, what reasons were discussed for recommending removal? Specific needs. More support and services. Academic concerns.			
0	0	3				GE 79d. If yes, how was the amount of time that this student would be removed from the general education classroom decided? IEP team. Team based on needs. Based on need for additional support and service.			

Y	N	NA	D K	Not Obs	% #	Citation	Required Corrective Action Evidence of Change	Timelines and Resources	Closed Date
4	0	2				GE 79e. In the most recent IEP meeting, did the IEP team discuss whether this student could be educated satisfactorily in a general education classroom for the entire school day with supplementary aids and services?			
2	0	4				GE 84. If appropriate, are you implementing the positive behavior support plan for this student as written in the current IEP			
4	0	2				GE 92. If a student with an IEP is having behavioral difficulties in your classroom, do you address the behavior in your classroom rather than sending him/her back to the special education classroom to address the behavior issue unless indicated otherwise in the student's IEP?			
10	0	0				SE 105. Are the supplementary aids and services, including program modifications and specially designed instruction in the student's current IEP, being provided?			
10	0	0				SE 109. Is this student receiving the type and amount of special education instruction and related services specified in his/her current IEP?			
10	0	0				SE 110. Was this student's current IEP implemented no later than 10 school days after its completion or no later than the IEP implementation date?			
10	0	0				SE 111. If supports for school personnel are included in this student's current IEP, has the LEA provided those supports?			
9	0	1				SE 113. If required, were the testing accommodations included in this student's current IEP implemented?			
9	0	1				SE 114. Was the placement decision made by the IEP team after the annual goals, specially designed instruction, and related services were developed?			
10	0	0				SE 120. Is this student receiving the supports and services agreed upon in his/her current IEP, including related services?			
						<b>PROVISION OF ESY AND RELATED SERVICES INTERVIEW RESULTS (Parent &amp; Special Education Teacher)</b>			
4	0	2	0			P 42. If your child's current IEP includes psychological counseling as a related service, and he/she receives these services, including transportation, are they provided at no cost to you?			

Y	N	NA	DK	Not Obs	% #	Citation	Required Corrective Action Evidence of Change	Timelines and Resources	Closed Date
5	0	0	1			P 43. Was your child's need for extended school year (ESY) – which means services over the summer or during breaks from the regular school calendar - discussed at an IEP meeting?			
4	0	2	0			P 44. Did you receive an explanation of what would make your child eligible for ESY services?			
5	0	1	0			P 45. Did you agree with the IEP team's conclusion about your child's eligibility for ESY services?			
0	0	6	0			P 46. If you did not agree with the decision on ESY eligibility, were you given a written notice (NOREP/PWN) explaining that you could ask for a due process hearing?			
2	0	4	0			P 47. If your child was determined to be eligible for ESY services, did the IEP team decide upon the goals and services needed for the ESY program?			
9	0	1				SE 121. Was the consideration of ESY eligibility discussed during this student's current IEP meeting?			
5	0	5				SE 122. If this student was determined to be ESY eligible, did the IEP team determine what goals and services were needed and include them in the IEP?			
0	0	10				SE 122a. At the most recent IEP meeting, did the IEP team discuss the development of a plan to transition this student back into the school district (or charter school if student is enrolled in a charter school) with supplementary aids and services?			
0	0	10				SE 122b. Are staff from the home district (or charter school if student is enrolled in a charter school) involved with the planning and implementation of this student program?			
0	0	10				SE 122c. Does this student go on field trips, attend school functions or participate in extracurricular activities with his/her same age/grade peers who are non-disabled?			
0	0	10				SE 122d. Does this student need supplementary aids and services to participate in non-academic and/or extra-curricular activities?			
0	0	10				SE 122e. If yes, are needed supplementary aids and services being provided to this student?			
0	0	10				SE 122f. Are there routine opportunities for this student to interact with non-disabled peers that are planned and/or facilitated by school personnel?			



Y	N	NA	D K	Not Obs	% #	Citation	Required Corrective Action Evidence of Change	Timelines and Resources	Closed Date
						<b>SECONDARY TRANSITION (Parent &amp; Special Education Teacher)</b>			
2	0	3	1			P 50. If your child is age 14 or older was he/she invited to participate in the IEP meeting for transition planning?			
4	0	0	2			P 50a. In the most recent IEP meeting for your child, did you discuss whether your child could be educated in a general education classroom for the entire school day?			
0	5	1	0			P 50b. In the most recent IEP meeting, did the IEP team recommend removal of your child from the general education classroom for any part of the school day?			
0	0	6	0			P 50c. If yes, what reasons were discussed for recommending removal?			
0	0	6	0			P 50d. If yes, how was the amount of time that your child would be removed from the general education classroom decided?			
2	1	1	2			P 50e. In the most recent IEP meeting, did the IEP team discuss whether your child could be educated satisfactorily in a general education classroom for the entire school day with supplementary aids and services?			
5	1	0	0			P 50f. In your opinion, is your child benefiting from participation in the general education classroom?			
0	0	1	0			P 50g. If yes, in what ways? Interacts with peers. Works on skills in groups. Opportunity for learning and socialization with peers. Improving in core content classes. Improving content area and learning life skills.			
0	0	5	0			P 50h. If no, what does your child need that he/she is not receiving in the class? Too fast paced, content needs to be slower and broken down more.			
					2 0 0 0 0 4	P 59. I am satisfied with the transition services developed for my child.  Always Sometimes Rarely Never Don't Know Does not Apply			
						P 60. My child is learning skills that will lead to a high school diploma and further education and/or employment.			

Y	N	NA	D K	Not Obs	% #	Citation	Required Corrective Action Evidence of Change	Timelines and Resources	Closed Date
					6 0 0 0 0 0	Always Sometimes Rarely Never Don't Know Does not Apply			
6	0	4				SE 116. Were this student's desired post school outcomes considered when the IEP team developed the annual goals?			
10	0	0				SE 123. Where appropriate, does the LEA invite a representative of a participating agency that is likely to be responsible for providing or paying for transition services to the IEP meeting?			
						<b>Topical Area 6: NOREP/PWN</b>			
						<b>(File Reviews)</b>			
10	0	0				FR 328. NOREP/PWN is present in the student file			
9	1	0			10%	FR 329. Demographic data			
10	0	0				FR 330. Type of action taken			
10	0	0				FR 331. A description of the action proposed or refused by the LEA			
10	0	0				FR 332. An explanation of why the LEA proposed or refused to take the action			
10	0	0				FR 333. A description of the other options the IEP team considered and the reason why those options were rejected			
10	0	0				FR 334. Description of each evaluation procedure, assessment, record or report used as the basis for proposed action or action refused			
9	0	1				FR 335. Description of other factor(s) relevant to LEA's proposal or refusal			
10	0	0				FR 336. Educational placement recommended (including amount and type)			
9	1	0			10%	FR 337. Signature of school district superintendent or charter school CEO or designee			
9	1	0			10%	FR 338. Parent signature or documentation of reasonable efforts to obtain consent (e.g. mailed to parents, certified mail, visit to the parent's home, etc.)			
9	1	0			10%	FR 339. Parent has selected a consent option			
10	0	0				FR 340. NOREP/PWN reflects the educational placement indicated on the student's IEP			
						<b>INTERVIEW RESULTS (Parent)</b>			

Y	N	NA	D K	Not Obs	% #	Citation	Required Corrective Action Evidence of Change	Timelines and Resources	Closed Date
0	0	6	0			P 34. If services that you requested for your child were rejected by the school, did you receive a written notice (NOREP/PWN) explaining why the request was rejected?			
					5 1 0 0 0 0	Always Sometimes Rarely Never Don't Know Does not Apply			
						<b>Topical Area 7: Additional Interview Responses</b>			
						<b>INTERVIEW RESULTS (Parent &amp; Special Education Teacher)</b>			
					5 0 0 0 1 0	P 54. I am a partner with school personnel when we plan my child's education program. Always Sometimes Rarely Never Don't Know Does not Apply			
		0	0		1 2 1 1 2 2 5 1 5 1	P 66. Tell me anything you really like about your child's special education program. a. modifications b. progress reports c. staff-aide ratios d. staff's knowledge, training e. instructional materials g. staff open to suggestions, good communication i. support services j. student ratios k. staff's understanding and attitude l. more inclusion			
		3	0			P 67. Tell me anything you would like to change about the program.			

Y	N	NA	DK	Not Obs	% #	Citation	Required Corrective Action Evidence of Change	Timelines and Resources	Closed Date
					1	a. modifications			
					1	b. progress reports			
					1	d. staff's knowledge, training			
					1	e. instructional materials			
					1	g. staff open to suggestions, good communication			
					2	m. services provided outside neighborhood school			
					1	n. other			
						Fast pace setting in some areas.			
		0	0			P 68. The school explains what options parents have if the parent disagrees with a decision of the school.			
					2	a. Very strongly agree			
					4	c. Agree			
						P 69. Additional comments about your child's program. Sometimes I would like to have face to face meetings with specific staff.			
10	0	0				SE 101. Do you hold the required certification to implement this student's program?			
10	0	0				SE 101a. Have you received sufficient training, technical assistance and other support to teach this student?			
0	0	10				SE 101b. If no, what training or support would assist you?			
						<b>Topical Area 8: Other Non-compliance Issues</b>			
						<b>Topical Area 9: Other Improvement Plan Issues</b>			
						FSA 15A Parent Survey Results	Based on the results of the parent survey, the LEA will develop an improvement plan to address parent trainings.		
						FSA 19A Teacher Survey Results	Based on the results of the teacher survey, the LEA will develop an improvement plan to address teacher trainings, such as writing NOREPs, behavior management, use and knowledge of AT devices, and understanding how to differentiate instruction.		



## IEP Meeting Procedure

### **22 Pa Code §711.3(b)(24) incorporating:**

### **34 CFR §300.320-300.324. IEP**

(a) In addition to the requirements incorporated by reference (see 34 CFR 300.320—300.324), the IEP of each student with a disability must include:

(1) A description of the type or types of support as defined in this paragraph that the student will receive, the determination of which may not be based on the categories of the child's disability alone. Students may receive more than one type of support as appropriate and as outlined in the IEP and in accordance with this chapter. Special education supports and services may be delivered in the regular classroom setting and other settings as determined by the IEP team. In determining the educational placement, the IEP team must first consider the regular classroom with the provision of supplementary aids and services before considering the provision of services in other settings.

(i) *Autistic support.* Services for students with the disability of autism who require services to address needs primarily in the areas of communication, social skills or behaviors consistent with those of autism spectrum disorders. The IEP for these students must address needs as identified by the team which may include, as appropriate, the verbal and nonverbal communication needs of the child; social interaction skills and proficiencies; the child's response to sensory experiences and changes in the environment, daily routine and schedules; and, the need for positive behavior supports or behavioral interventions.

(ii) *Blind-visually impaired support.* Services for students with the disability of visual impairment including blindness, who require services to address needs primarily in the areas of accessing print and other visually-presented materials, orientation and mobility, accessing public and private accommodations, or use of assistive technologies designed for individuals with visual impairments or blindness. For students who are blind or visually impaired, the IEP must include a description of the instruction in Braille and the use of Braille unless the IEP team determines, after the evaluation of the child's reading and writing needs, and appropriate reading and writing media, the extent to which Braille will be taught and used for the student's learning materials.

(iii) *Deaf and hard of hearing support.* Services for students with the disability of deafness or hearing impairment, who require services to address needs primarily in the area of reading, communication, accessing public and private accommodations or use of assistive technologies designed for individuals with deafness or hearing impairment. For these students, the IEP must include a communication plan to address the language and communication needs, opportunities for direct communications with peers and professional personnel in the child's language and communication mode, academic level, and full range of needs, including opportunities for direct instruction in the child's language and communication mode; and assistive technology devices and services.

(iv) *Emotional support.* Services for students with a disability who require services primarily in the areas of social or emotional skills development or functional behavior.

(v) *Learning support.* Services for students with a disability who require services primarily in the areas of reading, writing, mathematics, or speaking or listening skills related to academic performance.

(vi) *Life skills support.* Services for students with a disability who require services primarily in the areas of academic, functional or vocational skills necessary for independent living.

(vii) *Multiple disabilities support.* Services for students with more than one disability the result of which is severe impairment requiring services primarily in the areas of academic, functional or vocational skills necessary for independent living.

(viii) *Physical support.* Services for students with a physical disability who require services primarily in the areas of functional motor skill development, including adaptive physical education or use of assistive technologies designed to provide or facilitate the development of functional motor capacity or skills.

(ix) *Speech and language support.* Services for students with speech and language impairments who require services primarily in the areas of communication or use of assistive technologies designed to provide or facilitate the development of communication capacity or skills.

(2) Supplementary aids and services in accordance with 34 CFR 300.42 (relating to supplementary aids and services).

(3) A description of the type or types of support (relating to personnel). *Note: May use as a guide but 22 Pa Code Chapter 14 not applicable to charters. 22 Pa Code Chapter 711.5 has the same content as to personnel but does not contain levels of support and caseloads as this is more dependent on individual charter school Charter Applications and Charters granted.*

(4) The location where the student attends school and whether this is the school the student would attend if the student did not have an IEP.

(5) For students who are 14 years of age or older, a transition plan that includes appropriate measurable postsecondary goals related to training, education, employment and, when appropriate, independent living skills.

(6) The IEP of each student shall be implemented as soon as possible, but no later than 10 school days after its completion.

(7) Every student receiving special education and related services provided for in an IEP developed prior to July 1, 2008, shall continue to receive the special education and related services under that IEP, subject to the terms, limitations and conditions set forth in law.

(b) In addition to the requirements incorporated by reference in 34 CFR 300.324 (relating to development, review, and revision of IEP), each school entity shall designate persons responsible to coordinate transition activities.

### **Scope and Application:**

IEPs must be reviewed annually at a minimum. Special Education Case Managers must ensure they schedule meetings in advance to meet required timelines. Parents/Legal Guardians cannot halt the IEP timeline due to refusal to communicate with the Special Education Case Manager, lack of availability, or disagreement with any/all of IEP. If such circumstances arise, a PWN/NOREP may be issued to memorialize school's attempts to obtain Parent/Legal Guardian's cooperation as an IEP Team member and school's attempts to comply with applicable timelines pursuant to IDEA and Chapter 711.

### **Responsibilities:**

Special Education Case Manager	Schedule the IEP meeting. Draft the special education documents.
--------------------------------	---

	<p>Create and send IEP Invitation</p> <p>Create and send procedural safeguards notice AND letter with Invitation to Parent</p> <p>Create and send excusal for team members</p> <p>Send out IEP Input Form</p> <p>Provide drafted documents and IEP Analysis to LEA 48 hours prior to IEP meeting</p> <p>Make relevant changes per the IEP meeting</p> <p>Finalize all IEP documents</p> <p>Complete doc2file procedures for submission</p>
LEA	<p>Review IEP documents prior to the meeting</p> <p>Assure changes needed prior, during and after the meeting were completed</p> <p>Complete the IEP Analysis form</p>
General Education Teacher	<p>Provide input for student prior to meeting to include classroom data and observations</p> <p>Attend the IEP meeting</p> <p>Review finalized specially designed instruction</p>

**Procedure:**

1. IEP Meeting Scheduling & Attempts

- a. Special Education Case Managers must contact the Parent/Legal Guardian to schedule the IEP meeting at least 30 days in advance of the IEP due date. Attempts to schedule should be made via phone, email, text, and/or mail, and documented in the student's file.
- b. Special Education Case Managers should attempt to contact the Parent/Legal Guardian in at least 2 different ways over 3 or more days (no more than 5 days). If the Parent/Legal Guardian is not responsive on the third attempt the Special Education Case Manager should provide the date and time of the IEP meeting to the Parent/Legal Guardian via voice mail and email, and document attempts in the student's file.
  - i. Special Education Case Managers should schedule the first attempt IEP meeting for a date at least three weeks before the IEP due date to include an IEP Invitation. Even if the Parent/Legal Guardian does not respond to the invite the team should convene and attempt to call the Parent/Legal Guardian at the agreed upon time.
  - ii. If the Parent/Legal Guardian does not show to the first scheduled attempt for the IEP meeting, the Special Education Case Manager should schedule the second attempt IEP meeting for a date at least 2 weeks before the IEP due date to include an IEP Invitation. This should be done via VM, email, text, and or mail but at least 2 ways, and document attempts in the student's file.
  - iii. If the Parent/Legal Guardian does not show to the second scheduled

attempt for the IEP meeting, the Special Education Case Manager should schedule the third attempt IEP meeting for a date at least 1 week before the IEP due date. This should be done via VM, email, text, and or mail but at least 2 ways.

- c. The IEP meeting must also be scheduled via the Outlook calendar with the IEP team. The invitation should be sent to all Agora staff participating in the IEP meeting. **The invitation should include the BBC link, Teams link and/or phone conference line.** Do not send this invitation to any providers that do not work for Agora. A separate email with IEP meeting information should be sent to the provider.
- d. If a meeting cannot be held due to the fault of the school or representation of the school, then that cannot be counted as an attempt (i.e. a required team member does not show). Once a meeting is accepted, all parties are expected to attend the IEP meeting unless the Special Education Case Manager is notified 48 hours in advance of the meeting.
  - i. Required members of the IEP meeting include:
    1. Parent/Legal Guardian
    2. Student (who is required to be invited from the age of 14 years and on)
    3. Special Education Teacher
    4. General Education Teacher
    5. LEA
    6. Related Service Providers (if applicable)
  - ii. If the student is transitioning from a 504 service agreement to an IEP, the School Counselor must be invited to the IEP meeting and included as a member of the IEP team.
- e. In the event of Divorced Parent/Legal Guardians, an invitation must be sent to both Parents/Legal Guardians for the same date and time. The school must attempt to have both Parents/Legal Guardians present in order to facilitate true team decisions unless court orders provide the school with other guidance.
  - i. If one Parent/Legal Guardian attends and the other Parent/Legal Guardian does not, the team should follow the procedure for scheduling 3 attempts to hold the meeting with both Parents/Legal Guardians.
  - ii. If one Parent/Legal Guardian declines to attend a meeting with the other Parent/Legal Guardian present, advise that there is the option of an ODR Facilitated IEP Team Meeting, whereas the facilitator will be primarily attending to keep order and have all team members' input considered at the meeting, in a respectful manner. The Special Education Case Manager must document the offer of the ODR Facilitated Meeting in a writing to both Parents/Legal Guardians as it is a voluntary method.
  - iii. If Parents/Legal Guardians do not agree to attend with or without a facilitator, then with all documentation, the school may proceed with holding separate meetings with scribing of comments/input by the respective Parents/Legal Guardians so that all input be shared with the other Parent/Legal Guardian at their meeting.

## 2. IEP Meeting Documents

- a. Once the IEP meeting has been scheduled the Procedural Safeguards Notice and Letter, IEP Invitation, draft IEP, and ER/RR should be emailed or mailed to the Parent/Legal Guardian and Parental Consent to Excuse Members from



Attending the IEP Team Meeting (if necessary). The Procedural Safeguards Notice and Letter and IEP Invitation should be sent within 48 hours to the Parent/Legal Guardian. The IEP and Parental Consent to Excuse (if necessary) should be sent to the Parent/Legal Guardian at least 24 hours in advance of the meeting. The Parental Consent to Excuse should be sent to the Parent/Legal Guardian in advance if a team member is not able to attend the IEP meeting. This should be utilized for most often if related service providers are unable to attend; however reasonable attempts must be made to obtain written input, which should progress data and may also include anecdotal information, from related service providers, in order to provide Parent/Legal Guardian with substantive information as to the student's progress. The Parental Consent to Excuse does not need to be sent for general education teachers as long as one of the student's general education teachers is able to attend. Required IEP team members cannot be excused from the IEP meeting. Refer to "Documenting IEP Team Participation" for required team member attendance.

- i. This should be provided to the Parent/Legal Guardian in advance when a team member will not be able to attend, but signature can be obtained during the IEP meeting if the Parent/Legal Guardian has not indicated he/she does not object to the team member's inability to attend.
  - ii. If a team member on the invitation does not attend unexpectedly, this should be presented to the Parent/Legal Guardian at the meeting, prior to proceeding in the event that the Parent/Legal Guardian elects not to go through with the IEP meeting until such team member is present.
- a. If the student has two IDEA Parent/Legal Guardians in separate households, documents must be mailed to both and both must be invited to the meeting.
  - b. The documents must be sent out for each attempt with an updated IEP Invitation.
  - c. All above listed documents should be emailed to the IEP team at least 24 hours in advance.
  - d. The Special Education Case Manager must complete a pre-IEP analysis for every IEP. The Special Education Case Manager should mark each section of the IEP complete and add any notes for the LEA. The Special Education Case Manager should make a working live Google Document of the analysis within the IEP Analysis Folder and mark each section of the IEP complete along with any notes for the LEA 48 hours in advance. IEP Analysis forms are not to be emailed.
  - e. The NOREP should NOT be sent to the Parent/Legal Guardian in advance. NOREPs should always be dated the date provided to the Parent/Legal Guardian. If the NOREP is presented at the meeting it will match the meeting date. If the NOREP is sent on a later date the NOREP date should be the later date which is the date that the NOREP is actually sent.

### 3. IEP Meeting Input Forms

- a. The Special Education Case Manager must create a separate teacher input google document for each student. Copy input template: [https://docs.google.com/document/d/111hLmOOR\\_5pq8-bnsAcQzO0wxDXMJPFsMLKaEQjzhDI/edit?usp=sharing](https://docs.google.com/document/d/111hLmOOR_5pq8-bnsAcQzO0wxDXMJPFsMLKaEQjzhDI/edit?usp=sharing)
  - i. The first page of the input form must include the directions for all team members invited. Each Input form must include the student's first name, last initial and student ID at the top of the first page (highlighted).
  - ii. The second page of the input form must include a chart with the example in the first row.

- b. The Special Education Case Manager must send the input form via an Outlook calendar invitation/reminder. The IEP Input calendar reminder is separate from the IEP meeting invitation.
  - i. The Input calendar reminder must be titled as: “student first name, last initial, ID – IEP Input Form Due”
  - ii. The Input calendar reminder should have a scheduled due date at least 3 days before the IEP meeting. Include the input form link.
  - iii. This should be sent to all IEP team participants with a reasonable amount of time to complete. Input is required by all – even if a teacher is declining attendance at the IEP meeting. Best practice is to send this 2-3 weeks before the meeting date.
  - iv. The “all day” box should be checked so that the reminder will appear at the top of the day and not block off any time during that day. The response box should be unchecked so no one can decline.
4. IEP Meeting Location
  - a. IEP meetings must be held in Blackboard Collaborate (BBC) or Teams unless there is a Parent/Legal Guardian request or other specific reason to do otherwise such as inability of Parent/Legal Guardian to attend due to their own disability(s) or need for translation if not English dominant and virtual translation services insufficient. All Special Education Case Managers must set up a free conference line in the event BBC and Teams are not working properly. All Special Education Case Managers should be prepared to call additional participants into the meeting via a 3-way call.
    - i. Meetings may be held in BBC while also using a free conference line simultaneously.
    - ii. The Parent/Legal Guardian or any providers that do not work for Agora should not be provided the conference line number unless approved by the Director or Assistant Director due to a special circumstance. The Parent/Legal Guardian or providers should be called in to the meeting. A Parent/Legal Guardian should NEVER be provided the conference line number.
    - iii. The BBC meeting link must be sent to the Parent/Legal Guardian or set up in the Parent/Legal Guardian’s Class Connect.
5. IEP Meeting Electronic Signatures
  - a. Special Education Case Managers must attempt to have the IEP Invitation, IEP Attendance, Medical Access, and NOREP signed during the IEP meeting in BBC.
  - b. The 10 day waiver must be signed if the ER/RR review meeting is held before the Parent/Legal Guardian has had 10 days to review the report. The Parent/Legal Guardian must agree to the waiver of the 10 day review period in order to hold the meeting.
6. The IEP Analysis must be reviewed and updates must be made to the IEP draft before finalizing.
7. Special Education Case Managers must submit all documents to Docs 2 File within 48 hours of the meeting.
8. Special Education Case Managers will email all finalized documents to the Parent/Legal Guardian. This would include the Invite, Excusal Form, IEP, NOREP,

and ER/RR if applicable. The Special Education Case Manager should then email the finalized IEP to all IEP team members.

9. If signatures were unable to be gathered at the IEP meeting, the Special Education Case Manager will submit all documents to Docs2File to be issued to the Parent/Legal Guardian for signature by the Records Assistants via Adobe Sign.
10. If a Parent/Legal Guardian requests in advance of the IEP meeting, pursuant to Board Policy on recording of IEP team meetings, to record the IEP meeting, the school should inquire of the Parent/Legal Guardian as to the reason for such request and document same in student records. However, even if Parent/Legal Guardian does not give disability-related or other legitimate reason for such request; given the likely claims by Parent/Legal Guardian in the future as to reasons provided to the school, the recording will be permitted if timely requested and the school also will record the IEP meeting per the Board Policy. If request not timely by Parent/Legal Guardian, the meeting may be reconvened at a later time to enable recording by the school in addition to the Parent/Legal Guardian recording. **Note: Please also see “Participation via Alternative Means and Recording of IEP Team Meeting” Board Policy.**

#### Document History

Authors	Reviewers	Date
Erinn Slacktish, Director of Special Education Jennifer Fisher, Director of Special Education	Erinn Hunt, Director of Special Education Jennifer Fisher, Director of Special Education	9/13/16
Erinn Slacktish, Director of Special Education Jennifer Fisher, Director of Special Education	Erinn Slacktish, Director of Special Education Jennifer Fisher, Director of Special Education	7/1/17
Erinn Slacktish, Director of Special Education Jennifer Fisher, Director of Special Education	Erinn Slacktish, Director of Special Education Jennifer Fisher, Director of Special Education	5/18/18
Jen Lucia, Assistant Director of Special Education	Erinn Slacktish, Director of Special Education Jennifer Fisher, Director of Special Education	10/14/19
Erinn Slacktish, Director of Special Education Danielle Schall, Assistant Director of Special Education	Makenna Snyder Legal Review	8/18/20
Maryann Johnson, Assistant Director of Special Education	Erinn Slacktish, Director of Special Education	10/21/20

# Agenda

- A Big Thank You
- Meet your ESY ADs
- What Can you Expect from your ESY ADs
- Duties & Responsibilities
- Substitute Information
- Timesheet Information
- Crisis Information
- ESY Folder 2022 and Essential Reminders
- Q&A

Please take note of any questions and save them for the end.



Event Title: ESY Case Manager Training												
Location: <a href="https://nam02.safelinks.protection.outlook.com/ap/t-59584e83/?url=https%3A%2F%2Fteams.microsoft.com%2F%2Fmeetup-join%2F19%253ameeting_YjQ5MWFhOWYtOWNJzi00MGU1LWE4NzYtZWUxOGUzNDA0N2Rh%2540thread.v2%2F0%3Fcontext%3D%257b%2522Tid%2522%253a%25221daf2f11-55f3-4b9b-b249-e66cb7cbbc22%2522%252c%2522Oid%2522%253a%2522c9bd3829-954d-4f76-a901-0f535c7fa941%2522%257d&amp;data=05%7C01%7Cvnatale%40agora.org%7Caaf59e9524424b2809c208da3cfc7725%7C1daf2f1155f34b9bb249e66cb7cbbc22%7C0%7C0%7C637889352270479327%7CUnknown%7CTWFpbG7">https://nam02.safelinks.protection.outlook.com/ap/t-59584e83/?url=https%3A%2F%2Fteams.microsoft.com%2F%2Fmeetup-join%2F19%253ameeting_YjQ5MWFhOWYtOWNJzi00MGU1LWE4NzYtZWUxOGUzNDA0N2Rh%2540thread.v2%2F0%3Fcontext%3D%257b%2522Tid%2522%253a%25221daf2f11-55f3-4b9b-b249-e66cb7cbbc22%2522%252c%2522Oid%2522%253a%2522c9bd3829-954d-4f76-a901-0f535c7fa941%2522%257d&amp;data=05%7C01%7Cvnatale%40agora.org%7Caaf59e9524424b2809c208da3cfc7725%7C1daf2f1155f34b9bb249e66cb7cbbc22%7C0%7C0%7C637889352270479327%7CUnknown%7CTWFpbG7</a>												
Start Date: 06/07/2022 3:00 PM												
SLOT - 06/07/2022 3:00 PM												
Educator First Name	Educator Last Name	Educator School	Presenter	Status	Signup Date	Waitlist Date	Hrs	Signed In	Approval	Credits Released	Comment	User Id
Christian	Baker	Middle School	Valerie Natale, Maryann Johnson	Approved	05/25/2022 9:08 AM		1.0	No	06/08/2022	No		720525
Theresa	Bash	Middle School	Valerie Natale, Maryann Johnson	Approved	05/25/2022 9:08 AM		1.0	No	06/08/2022	No		720395
Nicole	Chiado	Elementary School	Valerie Natale, Maryann Johnson	Approved	05/25/2022 9:08 AM		1.0	No	06/08/2022	No		916069
Meredith	Conway	Elementary School	Valerie Natale, Maryann Johnson	Approved	05/25/2022 9:08 AM		1.0	No	06/08/2022	No		720457
Jennifer	Fisher-Clark	Middle School	Valerie Natale, Maryann Johnson	Approved	05/25/2022 9:08 AM		1.0	No	06/08/2022	No		720404
David	Furka	Middle School	Valerie Natale, Maryann Johnson	Approved	05/25/2022 9:08 AM		1.0	No	06/08/2022	No		720587
Maria	Harlan	K-8	Valerie Natale, Maryann Johnson	Approved	05/25/2022 9:08 AM		1.0	No	06/08/2022	No		720797
Robin	Hartman	Elementary School	Valerie Natale, Maryann Johnson	Approved	05/25/2022 9:08 AM		1.0	No	06/08/2022	No		720620
Melanie	Hathaway	Middle School	Valerie Natale, Maryann Johnson	Approved	05/25/2022 9:08 AM		1.0	No	06/08/2022	No		720545
Maryann	Johnson	K-8	Valerie Natale, Maryann Johnson	Approved	05/25/2022 9:08 AM		1.0	No	06/08/2022	No		720459
Margret	Joseph	Elementary School	Valerie Natale, Maryann Johnson	Approved	05/25/2022 9:08 AM		1.0	No	06/08/2022	No		914487
Rebecca	Kenzakowski	High School	Valerie Natale, Maryann Johnson	Approved	05/25/2022 9:08 AM		1.0	No	06/08/2022	No		720311
Kristina	Lapsker	Elementary School	Valerie Natale, Maryann Johnson	Approved	05/25/2022 9:08 AM		1.0	No	06/08/2022	No		720599
Susan	Lipiec	Middle School	Valerie Natale, Maryann Johnson	Approved	05/25/2022 9:08 AM		1.0	No	06/08/2022	No		720820
Cathryn	Mack	K-8	Valerie Natale, Maryann Johnson	Approved	05/25/2022 9:08 AM		1.0	No	06/08/2022	No		720601
Valerie	Natale	High School	Valerie Natale, Maryann Johnson	Approved	05/25/2022 9:08 AM		1.0	No	06/08/2022	No		720678
Stephen	Nugent	High School	Valerie Natale, Maryann Johnson	Approved	05/25/2022 9:08 AM		1.0	No	06/08/2022	No		720735
Lynn	Pagliei	High School	Valerie Natale, Maryann Johnson	Approved	05/25/2022 9:08 AM		1.0	No	06/08/2022	No		720608
Michelle	Pelissier	K-8	Valerie Natale, Maryann Johnson	Approved	05/25/2022 9:08 AM		1.0	No	06/08/2022	No		720394
Amy	Raught	High School	Valerie Natale, Maryann Johnson	Approved	05/25/2022 9:08 AM		1.0	No	06/08/2022	No		720390
Carmen	Riggle	Elementary School	Valerie Natale, Maryann Johnson	Approved	05/25/2022 9:08 AM		1.0	No	06/08/2022	No		720770
Erin	Scrip	High School	Valerie Natale, Maryann Johnson	Approved	05/25/2022 9:08 AM		1.0	No	06/08/2022	No		720552
Beth	Shaffer	Middle School	Valerie Natale, Maryann Johnson	Approved	05/25/2022 9:08 AM		1.0	No	06/08/2022	No		720551
Erinn	Slacktish	High School	Valerie Natale, Maryann Johnson	Approved	05/25/2022 9:08 AM		1.0	No	06/08/2022	No		720696
Amber	Staley	High School	Valerie Natale, Maryann Johnson	Approved	05/25/2022 9:08 AM		1.0	No	06/08/2022	No		720649
Melissa	Stump	High School	Valerie Natale, Maryann Johnson	Approved	05/25/2022 9:08 AM		1.0	No	06/08/2022	No		720841
John	Thomas	Middle School	Valerie Natale, Maryann Johnson	Approved	05/25/2022 9:08 AM		1.0	No	06/08/2022	No		720307
Stacy	Vietmeier	K-8	Valerie Natale, Maryann Johnson	Approved	05/25/2022 9:08 AM		1.0	No	06/08/2022	No		720758
Shari	Widlund	High School	Valerie Natale, Maryann Johnson	Approved	05/25/2022 9:08 AM		1.0	No	06/08/2022	No		720723
Sasha	Young	High School	Valerie Natale, Maryann Johnson	Approved	05/25/2022 9:08 AM		1.0	No	06/08/2022	No		720833
Emily	Forrest	K-8	Valerie Natale, Maryann Johnson	Approved	05/25/2022 9:37 AM		1.0	No	06/08/2022	No		958921
Brittany	Brown	K-8	Valerie Natale, Maryann Johnson	Approved	06/07/2022 9:09 AM		1.0	No	06/08/2022	No		958922

# Push in Support Teacher

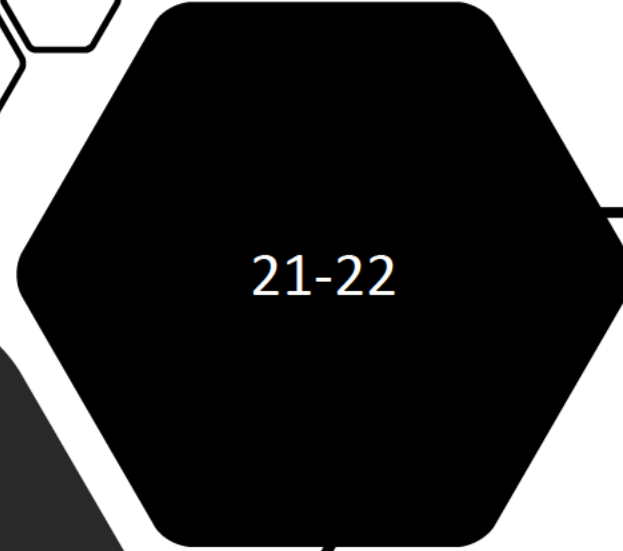
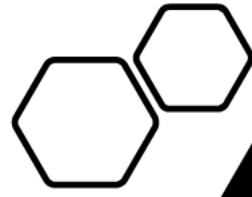

21-22

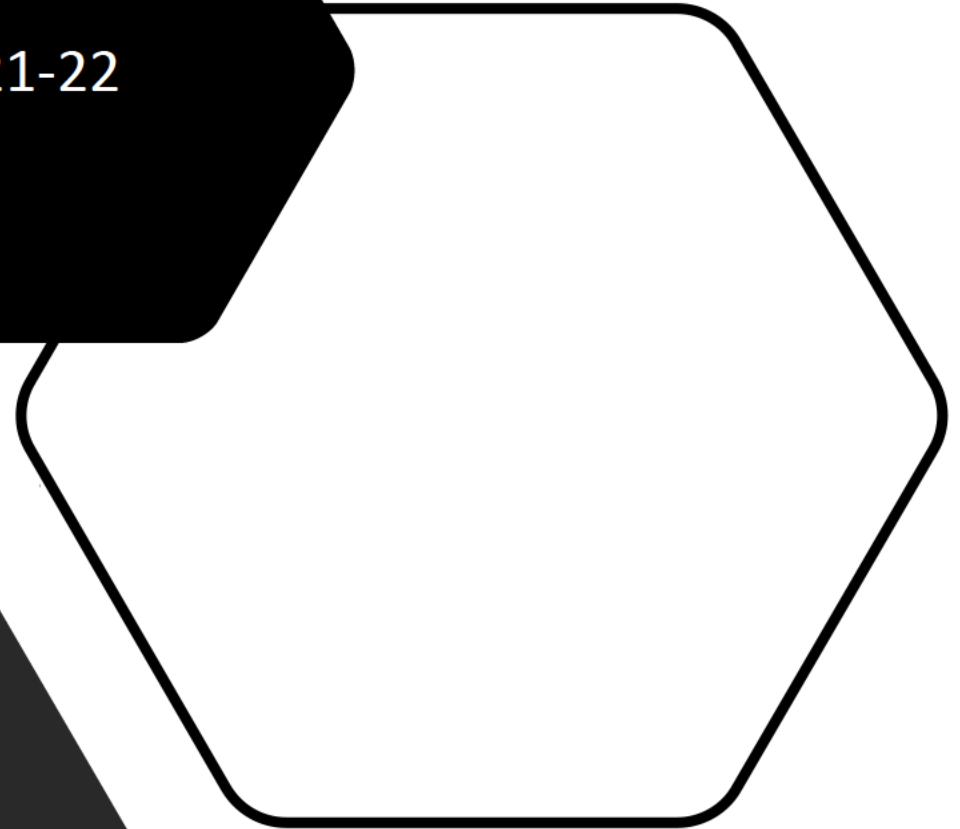

# Intentions

To allow time in the special ed teachers schedule to be able to work with their roster of students on IEP goal skills.

To provide more freedom with where you go to support students when they need it.

To provide more opportunities for collaboration between General and Special education teachers, providing more ownership of support for the General Ed teachers.

More time to work with students on  
Math and ELA goals!!

What is  
working?



# What isn't working?

- The current schedule only allows you to push in during certain times in the classes. It has been during direct instruction times, which doesn't allow for the opportunities to push into the classroom and support the students.

What ideas  
do you have  
for improving  
it for this  
year?

# Ideas that we came up with:

Target special ed students who are behind in assignments & help them complete them.

Send “to do” or “catch up” lists to student/parent/PCA of owed work.

**Assist with TDA's**

Provide Mods/Accom to Sci/History class. Meet in advance with Gen ed to know what material/concepts are coming up. Look at students Sdi's & their needs. Provide modifications to the Gen Ed teacher to use with students



Thoughts?  
Ideas?  
Suggestions?

1. Summary						
Attended participants	7					
Start time	2/10/22, 10:55:55 AM					
End time	2/10/22, 12:13:51 PM					
Meeting duration	1h 17m 56s					
Average attendance time	53m 35s					
2. Participants						
Name	First join	Last leave	In-meeting duration	Email	Participant ID (UPN)	Role
Stefanie Marcello	2/10/22, 10:56:01 AM	2/10/22, 11:59:36 AM	1h 3m 35s	smarcello@agora.org	smarcello@agora.org	Presenter
Stephanie Mannarino	2/10/22, 10:57:21 AM	2/10/22, 11:59:38 AM	1h 2m 17s	smannarino@agora.org	smannarino@agora.org	Presenter
Regina Mallon	2/10/22, 10:57:27 AM	2/10/22, 12:13:48 PM	1h 16m 21s	gmallon@agora.org	gmallon@agora.org	Presenter
Casey Chaffin	2/10/22, 10:58:59 AM	2/10/22, 11:59:36 AM	1h 37s	cchaffin@agora.org	cchaffin@agora.org	Presenter
Michelle Cukauskas	2/10/22, 10:59:24 AM	2/10/22, 12:13:51 PM	1h 14m 26s	mcukauskas@agora.org	mcukauskas@agora.org	Organizer
Laurie Super	2/10/22, 11:27:58 AM	2/10/22, 11:59:36 AM	31m 37s	lsuper@agora.org	lsuper@agora.org	Presenter
Melissa Franklin	2/10/22, 11:53:30 AM	2/10/22, 11:59:41 AM	6m 10s	mfranklin@agora.org	mfranklin@agora.org	Presenter
3. In-Meeting activities						
Name	Join time	Leave time	Duration	Email	Role	
Stefanie Marcello	2/10/22, 10:56:01 AM	2/10/22, 11:59:36 AM	1h 3m 35s	smarcello@agora.org	Presenter	
Stephanie Mannarino	2/10/22, 10:57:21 AM	2/10/22, 11:59:38 AM	1h 2m 17s	smannarino@agora.org	Presenter	
Regina Mallon	2/10/22, 10:57:27 AM	2/10/22, 12:13:48 PM	1h 16m 21s	gmallon@agora.org	Presenter	
Casey Chaffin	2/10/22, 10:58:59 AM	2/10/22, 11:59:36 AM	1h 37s	cchaffin@agora.org	Presenter	
Michelle Cukauskas	2/10/22, 10:59:24 AM	2/10/22, 12:13:51 PM	1h 14m 26s	mcukauskas@agora.org	Organizer	
Laurie Super	2/10/22, 11:27:58 AM	2/10/22, 11:59:36 AM	31m 37s	lsuper@agora.org	Presenter	
Melissa Franklin	2/10/22, 11:53:30 AM	2/10/22, 11:59:41 AM	6m 10s	mfranklin@agora.org	Presenter	

# TRANSITION TRAINING AGENDA



## Items to review today:

- IEP transition planning requirements
- Act 26 PIMS reporting questions
- Agency involvement
- Job training as a related service
- Work study program
- DCA reminders

## Poll the Audience

- A. I am a veteran transition plan writer and feel confident in my transition knowledge.
- B. I have knowledge of transition planning but I'm pretty sure I could use more training.
- C. I am brand new to transition planning and will be referencing this training often.
- D. I will not be writing IEP transition plans this year but want to stay fresh with my transition knowledge.

1. Summary						
Attended participants	118					
Start time	8/24/21, 11:09:38 AM					
End time	8/25/21, 9:19:31 AM					
Meeting duration	22h 9m 53s					
Average attendance time	2h 3m 45s					
2. Participants						
Name	First join	Last leave	In-meeting duration	Email	Participant ID (UPN)	Role
Cathryn Mack	8/24/21, 11:46:01 AM	8/24/21, 2:01:33 PM	2h 15m 32s	cmack@agora.org	cmack@agora.org	Attendee
Kimberly McLaughlin	8/24/21, 11:46:19 AM	8/24/21, 12:53:27 PM	1h 7m 8s	kmclaughlin@agora.org	kmclaughlin@agora.org	Attendee
Susan Lelko	8/24/21, 11:46:21 AM	8/24/21, 1:59:06 PM	2h 11m 16s	slelko@agora.org	slelko@agora.org	Attendee
Brett Stevens	8/24/21, 11:46:22 AM	8/24/21, 2:01:02 PM	2h 14m 40s	bstevens2@agora.org	bstevens2@agora.org	Attendee
Chris Baker	8/24/21, 11:48:21 AM	8/24/21, 2:01:14 PM	1h 57m 52s	cbaker@agora.org	cbaker@agora.org	Attendee
Tamara Kozak	8/24/21, 11:48:56 AM	8/24/21, 2:00:07 PM	2h 11m 11s	tkozak@agora.org	tkozak@agora.org	Attendee
Barb Cooper	8/24/21, 11:49:05 AM	8/24/21, 2:00:59 PM	2h 11m 53s	bcooper@agora.org	bcooper@agora.org	Attendee
Joy Fegely	8/24/21, 11:49:59 AM	8/24/21, 2:01:03 PM	2h 11m 4s	jfegely@agora.org	jfegely@agora.org	Attendee
Colien Byers	8/24/21, 11:50:17 AM	8/24/21, 2:00:16 PM	2h 9m 59s	cbyers@agora.org	cbyers@agora.org	Attendee
Amanda Moyer	8/24/21, 11:50:42 AM	8/24/21, 2:00:14 PM	2h 9m 32s	amoyer@agora.org	amoyer@agora.org	Attendee
Jennifer Flatley	8/24/21, 11:50:50 AM	8/24/21, 1:59:09 PM	2h 8m 18s	jflatley@agora.org	jflatley@agora.org	Attendee
Bridget Ellis	8/24/21, 11:51:22 AM	8/24/21, 2:01:06 PM	2h 9m 43s	bellis@agora.org	bellis@agora.org	Attendee
Allison Large	8/24/21, 11:51:32 AM	8/24/21, 1:59:15 PM	2h 7m 43s	alarge@agora.org	alarge@agora.org	Attendee
Kristy Welsh	8/24/21, 11:51:33 AM	8/24/21, 1:59:12 PM	2h 7m 39s	kwelsh@agora.org	kwelsh@agora.org	Attendee
Theresa Bash	8/24/21, 11:51:41 AM	8/24/21, 2:00:56 PM	2h 9m 15s	tbash@agora.org	tbash@agora.org	Attendee
Regina Kubica	8/24/21, 11:52:03 AM	8/24/21, 1:58:00 PM	2h 5m 56s	rkubica@agora.org	rkubica@agora.org	Attendee
Kimberly Paolino	8/24/21, 11:52:53 AM	8/24/21, 2:00:24 PM	2h 7m 31s	kpaolino@agora.org	kpaolino@agora.org	Attendee
Terri Hunkele	8/24/21, 11:53:14 AM	8/24/21, 1:59:41 PM	2h 6m 27s	thunkele@agora.org	thunkele@agora.org	Attendee
Kattreena Amodeo	8/24/21, 11:54:07 AM	8/24/21, 2:00:32 PM	2h 6m 25s	kamodeo@agora.org	kamodeo@agora.org	Attendee
Rachel Carmichael	8/24/21, 11:54:13 AM	8/24/21, 2:01:12 PM	2h 6m 58s	rcarmichael@agora.org	rcarmichael@agora.org	Attendee
Brittany Reamer	8/24/21, 11:54:19 AM	8/24/21, 2:00:54 PM	2h 6m 34s	breamer@agora.org	breamer@agora.org	Attendee
Jennifer Beeken	8/24/21, 11:54:33 AM	8/24/21, 2:01:12 PM	2h 6m 38s	jbeeken@agora.org	jbeeken@agora.org	Attendee
Kristal Costanzo	8/24/21, 11:54:37 AM	8/24/21, 2:01:14 PM	1h 59m 10s	kcostanzo@agora.org	kcostanzo@agora.org	Attendee
Danielle Pricer	8/24/21, 11:55:10 AM	8/24/21, 1:17:25 PM	1h 17m 2s	dpricer@agora.org	dpricer@agora.org	Attendee
Melissa McCracken	8/24/21, 11:55:14 AM	8/24/21, 2:00:52 PM	2h 1m 12s	mmccracken@agora.org	mmccracken@agora.org	Attendee

Molly Garczynski	8/24/21, 11:55:52 AM	8/24/21, 2:01:05 PM	2h 5m 12s	mgarczynski@agora.org	mgarczynski@agora.org	Attendee
Lisa Savitz	8/24/21, 11:55:55 AM	8/24/21, 2:01:07 PM	2h 5m 11s	lsavitz@agora.org	lsavitz@agora.org	Attendee
Jena Huffman	8/24/21, 11:56:08 AM	8/24/21, 2:00:15 PM	2h 4m 6s	jhuffman@agora.org	jhuffman@agora.org	Attendee
David Furka	8/24/21, 11:56:11 AM	8/24/21, 2:01:40 PM	2h 2m 55s	dfurka@agora.org	dfurka@agora.org	Attendee
Jenna Lee Dietrich	8/24/21, 11:56:12 AM	8/24/21, 2:01:08 PM	2h 4m 55s	jdietrich@agora.org	jdietrich@agora.org	Attendee
Melissa Stump	8/24/21, 11:56:17 AM	8/24/21, 2:00:48 PM	2h 4m 30s	mstump@agora.org	mstump@agora.org	Attendee
Brittany Froehlich	8/24/21, 11:56:21 AM	8/24/21, 2:01:06 PM	2h 4m 44s	BFroehlich@agora.org	BFroehlich@agora.org	Attendee
Melissa Love	8/24/21, 11:56:22 AM	8/24/21, 1:58:38 PM	2h 2m 16s	mlove@agora.org	mlove@agora.org	Attendee
Shannon Feeney Hoffmaster	8/24/21, 11:56:28 AM	8/24/21, 2:01:06 PM	2h 4m 38s	shoffmaster@agora.org	shoffmaster@agora.org	Attendee
Maria Harlan	8/24/21, 11:56:28 AM	8/24/21, 2:00:50 PM	1h 50m 52s	mharlan@agora.org	mharlan@agora.org	Attendee
Judy Deemer	8/24/21, 11:56:39 AM	8/24/21, 2:00:57 PM	2h 4m 17s	jdeemer@agora.org	jdeemer@agora.org	Attendee
Jill Moyer	8/24/21, 11:56:41 AM	8/24/21, 2:00:59 PM	2h 4m 18s	jmoyer2@agora.org	jmoyer2@agora.org	Attendee
Brianna Pontious	8/24/21, 11:56:47 AM	8/24/21, 2:01:08 PM	2h 4m 20s	bpontious@agora.org	bpontious@agora.org	Attendee
Heather Silberman	8/24/21, 11:56:53 AM	8/24/21, 2:03:38 PM	2h 4m 23s	hsilberman@agora.org	hsilberman@agora.org	Attendee
Leslie Spratt	8/24/21, 11:57:04 AM	8/24/21, 2:01:36 PM	2h 4m 31s	lspratt@agora.org	lspratt@agora.org	Attendee
Jennifer Cadieux	8/24/21, 11:57:07 AM	8/24/21, 2:01:12 PM	2h 4m 4s	jcadieux@agora.org	jcadieux@agora.org	Attendee
Lauren Svonavec	8/24/21, 11:57:18 AM	8/24/21, 2:00:28 PM	2h 3m 9s	lsvonavec@agora.org	lsvonavec@agora.org	Attendee
Morgan Witman	8/24/21, 11:57:21 AM	8/24/21, 2:03:36 PM	2h 6m 15s	mwitman@agora.org	mwitman@agora.org	Organizer
Shari Widlund	8/24/21, 11:57:26 AM	8/24/21, 1:59:19 PM	2h 1m 53s	swidlund@agora.org	swidlund@agora.org	Attendee
Jennifer Zollman	8/24/21, 11:57:33 AM	8/24/21, 2:00:21 PM	2h 2m 48s	jzollman@agora.org	jzollman@agora.org	Attendee
Kelly Berstecher	8/24/21, 11:57:46 AM	8/24/21, 2:01:03 PM	2h 3m 17s	kberstecher@agora.org	kberstecher@agora.org	Attendee
Michelle Pelissier	8/24/21, 11:57:49 AM	8/24/21, 2:00:51 PM	2h 1m 4s	mpelissier@agora.org	mpelissier@agora.org	Attendee
Veronica Jackson	8/24/21, 11:57:53 AM	8/24/21, 2:01:35 PM	2h 3m 42s	vjackson@agora.org	vjackson@agora.org	Attendee
Susan Lipiec	8/24/21, 11:57:56 AM	8/24/21, 2:00:58 PM	2h 3m 1s	slipiec@agora.org	slipiec@agora.org	Attendee
Heather Gallagher	8/24/21, 11:58:01 AM	8/24/21, 2:00:10 PM	2h 2m 9s	hgallagher@agora.org	hgallagher@agora.org	Attendee
Anna Baranoski	8/24/21, 11:58:01 AM	8/24/21, 2:01:02 PM	2h 3m 1s	abaranoski@agora.org	abaranoski@agora.org	Attendee
Lauren Lamison	8/24/21, 11:58:10 AM	8/24/21, 2:00:46 PM	2h 2m 35s	llamison@agora.org	llamison@agora.org	Attendee
Janelle Shaffer	8/24/21, 11:58:17 AM	8/24/21, 1:59:37 PM	2h 1m 20s	jshaffer3@agora.org	jshaffer3@agora.org	Attendee
Cathryn Ramsey	8/24/21, 11:58:22 AM	8/24/21, 2:00:52 PM	1h 35m 38s	cramsey@agora.org	cramsey@agora.org	Attendee
Tara Walker	8/24/21, 11:58:24 AM	8/24/21, 1:59:02 PM	1h 56m	twalker@agora.org	twalker@agora.org	Attendee
Cortney Barkley	8/24/21, 11:58:26 AM	8/24/21, 2:02:46 PM	2h 4m 19s	cbarkley@agora.org	cbarkley@agora.org	Attendee
Erinn Slacktish	8/24/21, 11:58:32 AM	8/24/21, 12:51:46 PM	53m 13s	eslacktish@agora.org	eslacktish@agora.org	Attendee
Sabrina Kennedy	8/24/21, 11:58:47 AM	8/24/21, 2:00:10 PM	1h 48m 13s	skennedy@agora.org	skennedy@agora.org	Attendee
Amber Staley	8/24/21, 11:58:48 AM	8/24/21, 2:00:09 PM	2h 1m 20s	astaley2@agora.org	astaley2@agora.org	Attendee



Lauren Kerns	8/24/21, 11:58:49 AM	8/24/21, 2:01:05 PM	2h 2m 15s	lkerns@agora.org	lkerns@agora.org	Attendee
Theresa Draeger	8/24/21, 11:58:50 AM	8/24/21, 2:01:22 PM	2h 2m 32s	tdraeger@agora.org	tdraeger@agora.org	Attendee
Michelle Olsavsky	8/24/21, 11:58:52 AM	8/24/21, 2:00:57 PM	2h 2m 4s	molsavsky@agora.org	molsavsky@agora.org	Attendee
Brittany Kieffer	8/24/21, 11:58:53 AM	8/24/21, 1:41:28 PM	1h 30m 8s	bkieffer@agora.org	bkieffer@agora.org	Attendee
Christine Thomas	8/24/21, 11:58:55 AM	8/24/21, 2:01:09 PM	2h 2m 13s	cthomas@agora.org	cthomas@agora.org	Attendee
Laura Stapf	8/24/21, 11:58:59 AM	8/24/21, 2:00:18 PM	2h 1m 18s	lstapf@agora.org	lstapf@agora.org	Attendee
Jesse Capitano	8/24/21, 11:59:03 AM	8/24/21, 2:00:58 PM	2h 1m 55s	jcapitano@agora.org	jcapitano@agora.org	Attendee
Brittney Cantwell	8/24/21, 11:59:13 AM	8/24/21, 2:00:46 PM	2h 1m 33s	bcantwell@agora.org	bcantwell@agora.org	Attendee
Sasha Young	8/24/21, 11:59:16 AM	8/24/21, 2:01:00 PM	2h 1m 44s	syoung@agora.org	syoung@agora.org	Attendee
Kimberly Fiscus	8/24/21, 11:59:19 AM	8/24/21, 2:01:05 PM	2h 1m 46s	kfiscus@agora.org	kfiscus@agora.org	Attendee
Jessica Linderman	8/24/21, 11:59:21 AM	8/24/21, 2:00:10 PM	2h 49s	jlinderman@agora.org	jlinderman@agora.org	Attendee
Joseph Passante	8/24/21, 11:59:22 AM	8/24/21, 1:18:49 PM	1h 19m 27s	jpassante@agora.org	jpassante@agora.org	Attendee
Kaelyn Hoffman	8/24/21, 11:59:31 AM	8/24/21, 2:01:01 PM	2h 1m 30s	khoffman@agora.org	khoffman@agora.org	Attendee
Melanie Stanforth	8/24/21, 11:59:33 AM	8/24/21, 2:01:03 PM	1h 50m 49s	mstanforth@agora.org	mstanforth@agora.org	Attendee
Danielle Schall	8/24/21, 11:59:43 AM	8/24/21, 2:01:04 PM	1h 19m 37s	dschall@agora.org	dschall@agora.org	Attendee
Whitney Bargerstock	8/24/21, 11:59:44 AM	8/24/21, 2:03:16 PM	2h 3m 31s	wbargerstock@agora.org	wbargerstock@agora.org	Presenter
Samantha Bonniger	8/24/21, 11:59:52 AM	8/24/21, 2:01:06 PM	2h 1m 13s	sbonniger@agora.org	sbonniger@agora.org	Attendee
Lynn Pagliei	8/24/21, 11:59:58 AM	8/24/21, 2:00:24 PM	2h 25s	lpagliei@agora.org	lpagliei@agora.org	Attendee
Kymberly Humanick	8/24/21, 12:00:17 PM	8/24/21, 2:01:05 PM	2h 48s	khumanick@agora.org	khumanick@agora.org	Attendee
Julie Doebereiner	8/24/21, 12:00:18 PM	8/24/21, 2:01:03 PM	1h 58m 5s	jdoebereiner@agora.org	jdoebereiner@agora.org	Attendee
Amanda Kammermeier	8/24/21, 12:00:24 PM	8/24/21, 2:01:13 PM	2h 49s	akammermeier@agora.org	akammermeier@agora.org	Attendee
Melissa Hale-Patterson	8/24/21, 12:00:27 PM	8/24/21, 2:01:00 PM	2h 32s	mpatterson@agora.org	mpatterson@agora.org	Attendee
Amanda Armstrong	8/24/21, 12:00:28 PM	8/24/21, 2:01:00 PM	2h 32s	aarmstrong@agora.org	aarmstrong@agora.org	Attendee
Nancy Reimers	8/24/21, 12:00:28 PM	8/24/21, 1:57:43 PM	1h 45m 32s	nreimers@agora.org	nreimers@agora.org	Attendee
Nicole Krol	8/24/21, 12:00:31 PM	8/24/21, 2:00:59 PM	2h 27s	nkrol@agora.org	nkrol@agora.org	Attendee
Carissa Emrick	8/24/21, 12:00:32 PM	8/24/21, 2:00:46 PM	2h 13s	cemrick@agora.org	cemrick@agora.org	Attendee
Angela Denham	8/24/21, 12:00:33 PM	8/24/21, 2:01:00 PM	2h 27s	adenham@agora.org	adenham@agora.org	Attendee
Anna Lepsch	8/24/21, 12:00:33 PM	8/24/21, 12:53:27 PM	52m 53s	alepsch@agora.org	alepsch@agora.org	Attendee
Rebekah Congdon	8/24/21, 12:00:33 PM	8/25/21, 8:23:13 AM	1h 56m 59s	rcongdon@agora.org	rcongdon@agora.org	Attendee
Lauren Radico	8/24/21, 12:01:04 PM	8/24/21, 2:01:54 PM	2h 50s	lradico@agora.org	lradico@agora.org	Attendee
Valerie Natale	8/24/21, 12:01:08 PM	8/24/21, 12:57:58 PM	56m 50s	vnatale@agora.org	vnatale@agora.org	Attendee
Gemma Mattox	8/24/21, 12:01:09 PM	8/24/21, 2:01:02 PM	1h 59m 53s	gmattox@agora.org	gmattox@agora.org	Attendee
Chelsey Panchura	8/24/21, 12:01:14 PM	8/24/21, 2:00:09 PM	1h 58m 55s	cpanchura@agora.org	cpanchura@agora.org	Attendee
Jennifer DePietro	8/24/21, 12:01:18 PM	8/24/21, 2:01:12 PM	1h 59m 53s	jdepietro@agora.org	jdepietro@agora.org	Attendee

Amber Brisbane	8/24/21, 12:01:55 PM	8/24/21, 2:00:59 PM	1h 59m 4s	abrisbane@agora.org	abrisbane@agora.org	Attendee
Breanne Scears	8/24/21, 12:01:56 PM	8/24/21, 1:59:37 PM	1h 57m 41s	bscears@agora.org	bscears@agora.org	Attendee
Lisa Brestensky	8/24/21, 12:02:07 PM	8/24/21, 2:00:57 PM	1h 58m 50s	lbrestensky@agora.org	lbrestensky@agora.org	Attendee
Kristina Lapsker	8/24/21, 12:02:09 PM	8/24/21, 2:00:24 PM	1h 58m 14s	klapsker@agora.org	klapsker@agora.org	Attendee
Erin Scrip	8/24/21, 12:02:16 PM	8/25/21, 9:19:31 AM	21h 17m 14s	escrip@agora.org	escrip@agora.org	Attendee
Tracey Ambuka	8/24/21, 12:02:21 PM	8/24/21, 2:00:58 PM	1h 58m 36s	tambuka@agora.org	tambuka@agora.org	Attendee
Serena Adams	8/24/21, 12:02:24 PM	8/24/21, 2:00:46 PM	1h 58m 22s	sadams@agora.org	sadams@agora.org	Attendee
Amy Raught	8/24/21, 12:02:32 PM	8/24/21, 2:01:12 PM	1h 58m 39s	araught@agora.org	araught@agora.org	Attendee
Patrick Lavelle	8/24/21, 12:02:37 PM	8/24/21, 2:00:03 PM	1h 57m 26s	plavelle@agora.org	plavelle@agora.org	Attendee
Stacy Vietmeier	8/24/21, 12:02:40 PM	8/24/21, 2:01:07 PM	1h 58m 27s	svietmeier@agora.org	svietmeier@agora.org	Attendee
Shelley Stump	8/24/21, 12:02:55 PM	8/24/21, 2:01:01 PM	1h 58m 5s	sstump@agora.org	sstump@agora.org	Attendee
Mindy Wesley	8/24/21, 12:03:04 PM	8/24/21, 1:46:26 PM	1h 43m 22s	mwesley@agora.org	mwesley@agora.org	Attendee
Colleen Freyvogel Bruss	8/24/21, 12:03:05 PM	8/24/21, 12:58:58 PM	55m 53s	cfreyvogel@agora.org	cfreyvogel@agora.org	Attendee
Jill Severino	8/24/21, 12:04:54 PM	8/24/21, 2:01:49 PM	1h 56m 54s	jseverino@agora.org	jseverino@agora.org	Attendee
Renee Perri	8/24/21, 12:05:02 PM	8/24/21, 2:01:02 PM	1h 55m 59s	rperri@agora.org	rperri@agora.org	Attendee
Katie O'Donnell	8/24/21, 12:06:55 PM	8/24/21, 1:59:34 PM	1h 52m 38s	kodonnell@agora.org	kodonnell@agora.org	Attendee
Jodeen Buckwalter	8/24/21, 12:08:42 PM	8/24/21, 1:59:20 PM	1h 50m 37s	jbuckwalter@agora.org	jbuckwalter@agora.org	Attendee
Heidi Dodge	8/24/21, 12:09:45 PM	8/24/21, 2:01:06 PM	1h 51m 20s	hdodge@agora.org	hdodge@agora.org	Attendee
Dana Pacolay	8/24/21, 12:11:55 PM	8/24/21, 1:59:50 PM	1h 47m 55s	dpacolay@agora.org	dpacolay@agora.org	Attendee
Jessica Barnhart	8/24/21, 12:27:07 PM	8/24/21, 2:01:08 PM	1h 34m 1s	jbarnhart@agora.org	jbarnhart@agora.org	Attendee
Melissa Gaso	8/24/21, 12:28:09 PM	8/24/21, 1:59:06 PM	1h 30m 57s	mgaso@agora.org	mgaso@agora.org	Attendee
Jennifer Fisher Clark	8/24/21, 12:37:08 PM	8/24/21, 12:59:41 PM	22m 33s	jclark@agora.org	jclark@agora.org	Attendee
Jen Lucia	8/24/21, 12:37:11 PM	8/24/21, 12:59:11 PM	22m	jlucia@agora.org	jlucia@agora.org	Attendee
Maryann Johnson	8/24/21, 12:52:55 PM	8/24/21, 12:57:58 PM	5m 3s	majohnson@agora.org	majohnson@agora.org	Attendee
Maura Basso	8/24/21, 1:13:58 PM	8/24/21, 2:35:22 PM	1h 21m 23s	mbasso@agora.org	mbasso@agora.org	Attendee
3. In-Meeting activities						
Name	Join time	Leave time	Duration	Email	Role	
Cathryn Mack	8/24/21, 11:46:01 AM	8/24/21, 2:01:33 PM	2h 15m 32s	cmack@agora.org	Attendee	
Kimberly McLaughlin	8/24/21, 11:46:19 AM	8/24/21, 12:53:27 PM	1h 7m 8s	kmclaughlin@agora.org	Attendee	
Susan Lelko	8/24/21, 11:46:21 AM	8/24/21, 1:01:39 PM	1h 15m 17s	slelko@agora.org	Attendee	
Susan Lelko	8/24/21, 1:03:06 PM	8/24/21, 1:59:06 PM	55m 59s	slelko@agora.org	Attendee	
Brett Stevens	8/24/21, 11:46:22 AM	8/24/21, 2:01:02 PM	2h 14m 40s	bstevens2@agora.org	Attendee	
Chris Baker	8/24/21, 11:48:21 AM	8/24/21, 11:48:48 AM	27s	cbaker@agora.org	Attendee	

Chris Baker	8/24/21, 12:03:48 PM	8/24/21, 2:01:14 PM	1h 57m 25s	cbaker@agora.org	Attendee	
Tamara Kozak	8/24/21, 11:48:56 AM	8/24/21, 2:00:07 PM	2h 11m 11s	tkozak@agora.org	Attendee	
Barb Cooper	8/24/21, 11:49:05 AM	8/24/21, 2:00:59 PM	2h 11m 53s	bcooper@agora.org	Attendee	
Joy Fegely	8/24/21, 11:49:59 AM	8/24/21, 2:01:03 PM	2h 11m 4s	jfegely@agora.org	Attendee	
Colien Byers	8/24/21, 11:50:17 AM	8/24/21, 2:00:16 PM	2h 9m 59s	cbyers@agora.org	Attendee	
Amanda Moyer	8/24/21, 11:50:42 AM	8/24/21, 2:00:14 PM	2h 9m 32s	amoyer@agora.org	Attendee	
Jennifer Flatley	8/24/21, 11:50:50 AM	8/24/21, 1:59:09 PM	2h 8m 18s	jflatley@agora.org	Attendee	
Bridget Ellis	8/24/21, 11:51:22 AM	8/24/21, 2:01:06 PM	2h 9m 43s	bellis@agora.org	Attendee	
Allison Large	8/24/21, 11:51:32 AM	8/24/21, 1:59:15 PM	2h 7m 43s	alarge@agora.org	Attendee	
Kristy Welsh	8/24/21, 11:51:33 AM	8/24/21, 1:59:12 PM	2h 7m 39s	kwelsh@agora.org	Attendee	
Theresa Bash	8/24/21, 11:51:41 AM	8/24/21, 2:00:56 PM	2h 9m 15s	tbash@agora.org	Attendee	
Regina Kubica	8/24/21, 11:52:03 AM	8/24/21, 1:58:00 PM	2h 5m 56s	rkubica@agora.org	Attendee	
Kimberly Paolino	8/24/21, 11:52:53 AM	8/24/21, 2:00:24 PM	2h 7m 31s	kpaolino@agora.org	Attendee	
Terri Hunkele	8/24/21, 11:53:14 AM	8/24/21, 1:59:41 PM	2h 6m 27s	thunkele@agora.org	Attendee	
Kattreena Amodeo	8/24/21, 11:54:07 AM	8/24/21, 2:00:32 PM	2h 6m 25s	kamodeo@agora.org	Attendee	
Rachel Carmichael	8/24/21, 11:54:13 AM	8/24/21, 2:01:12 PM	2h 6m 58s	rcarmichael@agora.org	Attendee	
Brittany Reamer	8/24/21, 11:54:19 AM	8/24/21, 2:00:54 PM	2h 6m 34s	breamer@agora.org	Attendee	
Jennifer Beeken	8/24/21, 11:54:33 AM	8/24/21, 2:01:12 PM	2h 6m 38s	jbeeken@agora.org	Attendee	
Kristal Costanzo	8/24/21, 11:54:37 AM	8/24/21, 12:50:03 PM	55m 25s	kcostanzo@agora.org	Attendee	
Kristal Costanzo	8/24/21, 12:57:28 PM	8/24/21, 2:01:14 PM	1h 3m 45s	kcostanzo@agora.org	Attendee	
Danielle Pricer	8/24/21, 11:55:10 AM	8/24/21, 1:03:54 PM	1h 8m 44s	dpricer@agora.org	Attendee	
Danielle Pricer	8/24/21, 1:09:07 PM	8/24/21, 1:17:25 PM	8m 18s	dpricer@agora.org	Attendee	
Melissa McCracken	8/24/21, 11:55:14 AM	8/24/21, 12:16:01 PM	20m 46s	mmccracken@agora.org	Attendee	
Melissa McCracken	8/24/21, 12:20:25 PM	8/24/21, 2:00:52 PM	1h 40m 26s	mmccracken@agora.org	Attendee	
Molly Garczynski	8/24/21, 11:55:52 AM	8/24/21, 2:01:05 PM	2h 5m 12s	mgarczynski@agora.org	Attendee	
Lisa Savitz	8/24/21, 11:55:55 AM	8/24/21, 2:01:07 PM	2h 5m 11s	lsavitz@agora.org	Attendee	
Jena Huffman	8/24/21, 11:56:08 AM	8/24/21, 2:00:15 PM	2h 4m 6s	jhuffman@agora.org	Attendee	
David Furka	8/24/21, 11:56:11 AM	8/24/21, 1:09:01 PM	1h 12m 50s	dfurka@agora.org	Attendee	
David Furka	8/24/21, 1:11:35 PM	8/24/21, 2:01:40 PM	50m 5s	dfurka@agora.org	Attendee	
Jenna Lee Dietrich	8/24/21, 11:56:12 AM	8/24/21, 2:01:08 PM	2h 4m 55s	jdietrich@agora.org	Attendee	
Melissa Stump	8/24/21, 11:56:17 AM	8/24/21, 2:00:48 PM	2h 4m 30s	mstump@agora.org	Attendee	
Brittany Froehlich	8/24/21, 11:56:21 AM	8/24/21, 2:01:06 PM	2h 4m 44s	BFroehlich@agora.org	Attendee	
Melissa Love	8/24/21, 11:56:22 AM	8/24/21, 1:58:38 PM	2h 2m 16s	mlove@agora.org	Attendee	
Shannon Feeney Hoffmaster	8/24/21, 11:56:28 AM	8/24/21, 2:01:06 PM	2h 4m 38s	shoffmaster@agora.org	Attendee	

Maria Harlan	8/24/21, 11:56:28 AM	8/24/21, 1:15:04 PM	1h 18m 35s	mharlan@agora.org	Attendee	
Maria Harlan	8/24/21, 1:28:32 PM	8/24/21, 2:00:50 PM	32m 17s	mharlan@agora.org	Attendee	
Judy Deemer	8/24/21, 11:56:39 AM	8/24/21, 2:00:57 PM	2h 4m 17s	jdeemer@agora.org	Attendee	
Jill Moyer	8/24/21, 11:56:41 AM	8/24/21, 2:00:59 PM	2h 4m 18s	jmoyer2@agora.org	Attendee	
Brianna Pontious	8/24/21, 11:56:47 AM	8/24/21, 2:01:08 PM	2h 4m 20s	bpontious@agora.org	Attendee	
Heather Silberman	8/24/21, 11:56:53 AM	8/24/21, 2:01:08 PM	2h 4m 15s	hsilberman@agora.org	Attendee	
Heather Silberman	8/24/21, 2:03:30 PM	8/24/21, 2:03:38 PM	8s	hsilberman@agora.org	Attendee	
Leslie Spratt	8/24/21, 11:57:04 AM	8/24/21, 2:01:36 PM	2h 4m 31s	lspratt@agora.org	Attendee	
Jennifer Cadieux	8/24/21, 11:57:07 AM	8/24/21, 2:01:12 PM	2h 4m 4s	jcadieux@agora.org	Attendee	
Lauren Svonavec	8/24/21, 11:57:18 AM	8/24/21, 2:00:28 PM	2h 3m 9s	lsvonavec@agora.org	Attendee	
Morgan Witman	8/24/21, 11:57:21 AM	8/24/21, 2:03:36 PM	2h 6m 15s	mwitman@agora.org	Organizer	
Shari Widlund	8/24/21, 11:57:26 AM	8/24/21, 1:59:19 PM	2h 1m 53s	swidlund@agora.org	Attendee	
Jennifer Zollman	8/24/21, 11:57:33 AM	8/24/21, 2:00:21 PM	2h 2m 48s	jzollman@agora.org	Attendee	
Kelly Berstecher	8/24/21, 11:57:46 AM	8/24/21, 2:01:03 PM	2h 3m 17s	kberstecher@agora.org	Attendee	
Michelle Pelissier	8/24/21, 11:57:49 AM	8/24/21, 1:01:16 PM	1h 3m 27s	mpelissier@agora.org	Attendee	
Michelle Pelissier	8/24/21, 1:03:14 PM	8/24/21, 2:00:51 PM	57m 37s	mpelissier@agora.org	Attendee	
Veronica Jackson	8/24/21, 11:57:53 AM	8/24/21, 2:01:35 PM	2h 3m 42s	vjackson@agora.org	Attendee	
Susan Lipiec	8/24/21, 11:57:56 AM	8/24/21, 2:00:58 PM	2h 3m 1s	slipiec@agora.org	Attendee	
Heather Gallagher	8/24/21, 11:58:01 AM	8/24/21, 2:00:10 PM	2h 2m 9s	hgallagher@agora.org	Attendee	
Anna Baranoski	8/24/21, 11:58:01 AM	8/24/21, 2:01:02 PM	2h 3m 1s	abaranoski@agora.org	Attendee	
Lauren Lamison	8/24/21, 11:58:10 AM	8/24/21, 2:00:46 PM	2h 2m 35s	llamison@agora.org	Attendee	
Janelle Shaffer	8/24/21, 11:58:17 AM	8/24/21, 1:59:37 PM	2h 1m 20s	jshaffer3@agora.org	Attendee	
Cathryn Ramsey	8/24/21, 11:58:22 AM	8/24/21, 12:03:10 PM	4m 48s	cramsey@agora.org	Attendee	
Cathryn Ramsey	8/24/21, 12:30:02 PM	8/24/21, 2:00:52 PM	1h 30m 50s	cramsey@agora.org	Attendee	
Tara Walker	8/24/21, 11:58:24 AM	8/24/21, 1:51:40 PM	1h 53m 15s	twalker@agora.org	Attendee	
Tara Walker	8/24/21, 1:56:17 PM	8/24/21, 1:59:02 PM	2m 45s	twalker@agora.org	Attendee	
Cortney Barkley	8/24/21, 11:58:26 AM	8/24/21, 2:02:46 PM	2h 4m 19s	cbarkley@agora.org	Attendee	
Erinn Slacktish	8/24/21, 11:58:32 AM	8/24/21, 12:51:46 PM	53m 13s	eslacktish@agora.org	Attendee	
Sabrina Kennedy	8/24/21, 11:58:47 AM	8/24/21, 12:19:01 PM	20m 13s	skennedy@agora.org	Attendee	
Sabrina Kennedy	8/24/21, 12:32:10 PM	8/24/21, 2:00:10 PM	1h 28m	skennedy@agora.org	Attendee	
Amber Staley	8/24/21, 11:58:48 AM	8/24/21, 2:00:09 PM	2h 1m 20s	astaley2@agora.org	Attendee	
Lauren Kerns	8/24/21, 11:58:49 AM	8/24/21, 2:01:05 PM	2h 2m 15s	lkerns@agora.org	Attendee	
Theresa Draeger	8/24/21, 11:58:50 AM	8/24/21, 2:01:22 PM	2h 2m 32s	tdraeger@agora.org	Attendee	
Michelle Olsavsky	8/24/21, 11:58:52 AM	8/24/21, 2:00:57 PM	2h 2m 4s	molsavsky@agora.org	Attendee	

Brittany Kieffer	8/24/21, 11:58:53 AM	8/24/21, 12:09:17 PM	10m 24s	bkieffer@agora.org	Attendee	
Brittany Kieffer	8/24/21, 12:12:05 PM	8/24/21, 12:30:08 PM	18m 3s	bkieffer@agora.org	Attendee	
Brittany Kieffer	8/24/21, 12:36:40 PM	8/24/21, 12:42:32 PM	5m 51s	bkieffer@agora.org	Attendee	
Brittany Kieffer	8/24/21, 12:45:37 PM	8/24/21, 1:41:28 PM	55m 50s	bkieffer@agora.org	Attendee	
Christine Thomas	8/24/21, 11:58:55 AM	8/24/21, 2:01:09 PM	2h 2m 13s	cthomas@agora.org	Attendee	
Laura Stapf	8/24/21, 11:58:59 AM	8/24/21, 2:00:18 PM	2h 1m 18s	lstapf@agora.org	Attendee	
Jesse Capitano	8/24/21, 11:59:03 AM	8/24/21, 2:00:58 PM	2h 1m 55s	jcapitano@agora.org	Attendee	
Brittney Cantwell	8/24/21, 11:59:13 AM	8/24/21, 2:00:46 PM	2h 1m 33s	bcantwell@agora.org	Attendee	
Sasha Young	8/24/21, 11:59:16 AM	8/24/21, 2:01:00 PM	2h 1m 44s	syoung@agora.org	Attendee	
Kimberly Fiscus	8/24/21, 11:59:19 AM	8/24/21, 2:01:05 PM	2h 1m 46s	kfiscus@agora.org	Attendee	
Jessica Linderman	8/24/21, 11:59:21 AM	8/24/21, 2:00:10 PM	2h 49s	jlinderman@agora.org	Attendee	
Joseph Passante	8/24/21, 11:59:22 AM	8/24/21, 1:18:49 PM	1h 19m 27s	jpassante@agora.org	Attendee	
Kaelyn Hoffman	8/24/21, 11:59:31 AM	8/24/21, 2:01:01 PM	2h 1m 30s	khoffman@agora.org	Attendee	
Melanie Stanforth	8/24/21, 11:59:33 AM	8/24/21, 1:46:20 PM	1h 46m 47s	mstanforth@agora.org	Attendee	
Melanie Stanforth	8/24/21, 1:57:00 PM	8/24/21, 2:01:03 PM	4m 2s	mstanforth@agora.org	Attendee	
Danielle Schall	8/24/21, 11:59:43 AM	8/24/21, 12:57:44 PM	58m 1s	dschall@agora.org	Attendee	
Danielle Schall	8/24/21, 1:39:27 PM	8/24/21, 2:01:04 PM	21m 36s	dschall@agora.org	Attendee	
Whitney Bargerstock	8/24/21, 11:59:44 AM	8/24/21, 2:03:16 PM	2h 3m 31s	wbargerstock@agora.org	Presenter	
Samantha Bonniger	8/24/21, 11:59:52 AM	8/24/21, 2:01:06 PM	2h 1m 13s	sbonniger@agora.org	Attendee	
Lynn Pagliei	8/24/21, 11:59:58 AM	8/24/21, 2:00:24 PM	2h 25s	lpagliei@agora.org	Attendee	
Kymberly Humanick	8/24/21, 12:00:17 PM	8/24/21, 2:01:05 PM	2h 48s	khumanick@agora.org	Attendee	
Julie Doebereiner	8/24/21, 12:00:18 PM	8/24/21, 1:44:13 PM	1h 43m 55s	jdoebereiner@agora.org	Attendee	
Julie Doebereiner	8/24/21, 1:46:52 PM	8/24/21, 2:01:03 PM	14m 10s	jdoebereiner@agora.org	Attendee	
Amanda Kammermeier	8/24/21, 12:00:24 PM	8/24/21, 2:01:13 PM	2h 49s	akammermeier@agora.org	Attendee	
Melissa Hale-Patterson	8/24/21, 12:00:27 PM	8/24/21, 2:01:00 PM	2h 32s	mpatterson@agora.org	Attendee	
Amanda Armstrong	8/24/21, 12:00:28 PM	8/24/21, 2:01:00 PM	2h 32s	aarmstrong@agora.org	Attendee	
Nancy Reimers	8/24/21, 12:00:28 PM	8/24/21, 12:27:29 PM	27m	nreimers@agora.org	Attendee	
Nancy Reimers	8/24/21, 12:39:10 PM	8/24/21, 1:57:43 PM	1h 18m 32s	nreimers@agora.org	Attendee	
Nicole Krol	8/24/21, 12:00:31 PM	8/24/21, 2:00:59 PM	2h 27s	nkrol@agora.org	Attendee	
Carissa Emrick	8/24/21, 12:00:32 PM	8/24/21, 2:00:46 PM	2h 13s	cemrick@agora.org	Attendee	
Angela Denham	8/24/21, 12:00:33 PM	8/24/21, 2:01:00 PM	2h 27s	adenham@agora.org	Attendee	
Anna Lepsch	8/24/21, 12:00:33 PM	8/24/21, 12:53:27 PM	52m 53s	alepsch@agora.org	Attendee	
Rebekah Congdon	8/24/21, 12:00:33 PM	8/24/21, 12:19:15 PM	18m 42s	rcongdon@agora.org	Attendee	
Rebekah Congdon	8/24/21, 12:22:50 PM	8/24/21, 2:00:39 PM	1h 37m 49s	rcongdon@agora.org	Attendee	

Rebekah Congdon	8/25/21, 8:22:45 AM	8/25/21, 8:23:13 AM	28s	rcongdon@agora.org	Attendee	
Lauren Radico	8/24/21, 12:01:04 PM	8/24/21, 2:01:54 PM	2h 50s	lradico@agora.org	Attendee	
Valerie Natale	8/24/21, 12:01:08 PM	8/24/21, 12:57:58 PM	56m 50s	vnatale@agora.org	Attendee	
Gemma Mattox	8/24/21, 12:01:09 PM	8/24/21, 2:01:02 PM	1h 59m 53s	gmattox@agora.org	Attendee	
Chelsey Panchura	8/24/21, 12:01:14 PM	8/24/21, 2:00:09 PM	1h 58m 55s	cpanchura@agora.org	Attendee	
Jennifer DePietro	8/24/21, 12:01:18 PM	8/24/21, 2:01:12 PM	1h 59m 53s	jdepietro@agora.org	Attendee	
Amber Brisbane	8/24/21, 12:01:55 PM	8/24/21, 2:00:59 PM	1h 59m 4s	abrisbane@agora.org	Attendee	
Breanne Scears	8/24/21, 12:01:56 PM	8/24/21, 1:59:37 PM	1h 57m 41s	bscears@agora.org	Attendee	
Lisa Brestensky	8/24/21, 12:02:07 PM	8/24/21, 2:00:57 PM	1h 58m 50s	lbrestensky@agora.org	Attendee	
Kristina Lapsker	8/24/21, 12:02:09 PM	8/24/21, 2:00:24 PM	1h 58m 14s	klapsker@agora.org	Attendee	
Erin Scrip	8/24/21, 12:02:16 PM	8/25/21, 9:19:31 AM	21h 17m 14s	escrip@agora.org	Attendee	
Tracey Ambuka	8/24/21, 12:02:21 PM	8/24/21, 2:00:58 PM	1h 58m 36s	tambuka@agora.org	Attendee	
Serena Adams	8/24/21, 12:02:24 PM	8/24/21, 2:00:46 PM	1h 58m 22s	sadams@agora.org	Attendee	
Amy Raught	8/24/21, 12:02:32 PM	8/24/21, 2:01:12 PM	1h 58m 39s	araught@agora.org	Attendee	
Patrick Lavelle	8/24/21, 12:02:37 PM	8/24/21, 2:00:03 PM	1h 57m 26s	plavelle@agora.org	Attendee	
Stacy Vietmeier	8/24/21, 12:02:40 PM	8/24/21, 2:01:07 PM	1h 58m 27s	svietmeier@agora.org	Attendee	
Shelley Stump	8/24/21, 12:02:55 PM	8/24/21, 2:01:01 PM	1h 58m 5s	sstump@agora.org	Attendee	
Mindy Wesley	8/24/21, 12:03:04 PM	8/24/21, 1:46:26 PM	1h 43m 22s	mwesley@agora.org	Attendee	
Colleen Freyvogel Bruss	8/24/21, 12:03:05 PM	8/24/21, 12:58:58 PM	55m 53s	cfreyvogel@agora.org	Attendee	
Jill Severino	8/24/21, 12:04:54 PM	8/24/21, 2:01:49 PM	1h 56m 54s	jseverino@agora.org	Attendee	
Renee Perri	8/24/21, 12:05:02 PM	8/24/21, 2:01:02 PM	1h 55m 59s	rperri@agora.org	Attendee	
Katie O'Donnell	8/24/21, 12:06:55 PM	8/24/21, 1:59:34 PM	1h 52m 38s	kodonnell@agora.org	Attendee	
Jodeen Buckwalter	8/24/21, 12:08:42 PM	8/24/21, 1:59:20 PM	1h 50m 37s	jbuckwalter@agora.org	Attendee	
Heidi Dodge	8/24/21, 12:09:45 PM	8/24/21, 2:01:06 PM	1h 51m 20s	hdodge@agora.org	Attendee	
Dana Pacolay	8/24/21, 12:11:55 PM	8/24/21, 1:59:50 PM	1h 47m 55s	dpacolay@agora.org	Attendee	
Jessica Barnhart	8/24/21, 12:27:07 PM	8/24/21, 2:01:08 PM	1h 34m 1s	jbarnhart@agora.org	Attendee	
Melissa Gaso	8/24/21, 12:28:09 PM	8/24/21, 1:59:06 PM	1h 30m 57s	mgaso@agora.org	Attendee	
Jennifer Fisher Clark	8/24/21, 12:37:08 PM	8/24/21, 12:59:41 PM	22m 33s	jclark@agora.org	Attendee	
Jen Lucia	8/24/21, 12:37:11 PM	8/24/21, 12:59:11 PM	22m	jlucia@agora.org	Attendee	
Maryann Johnson	8/24/21, 12:52:55 PM	8/24/21, 12:57:58 PM	5m 3s	majohnson@agora.org	Attendee	
Maura Basso	8/24/21, 1:13:58 PM	8/24/21, 2:35:22 PM	1h 21m 23s	mbasso@agora.org	Attendee	

# CONDUCT FOR PROVIDING IN-HOME AND VIRTUAL SERVICES AGENDA

- Thank you!!
- Expectations:Accepting the Case
- Expectations:What should I do if I cannot schedule?
- Expectations:What should I do if the Student missed sessions?
- Expectations in the Home:Arriving at the Home and Cancellations
- Expectations in the Home: Safety
- Expectations in the Home: Health & Safety Plan
- Expectations in the Home: Conduct
- Expectations in the Home: Confidentiality
- Expectations in the virtual setting
- Provider Names and Logging Into NewRow
- Expectations in Newrow
- Communication in NewRow
- Expectations: Communication
- Questions or Concerns regarding Curriculum, Instruction, Etc.
- Above all else...
- Any Questions?

Meeting Summary						
Total Number of Participants	137					
Meeting Title	Related Services Training					
Meeting Start Time	8/26/2021, 2:45:03 PM					
Meeting End Time	8/26/2021, 4:02:57 PM					
Meeting Id	f527cca7-bc75-41a1-9432-532215889006					
Full Name	Join Time	Leave Time	Duration	Email	Role	Participant ID (UPN)
Melanie Stanforth	8/26/2021, 2:45:03 PM	8/26/2021, 3:48:24 PM	1h 3m	mstanforth@agora.org	Presenter	mstanforth@agora.org
Michelle Pelissier	8/26/2021, 2:45:09 PM	8/26/2021, 3:43:39 PM	58m 30s	mpelissier@agora.org	Presenter	mpelissier@agora.org
Amy Raught	8/26/2021, 2:45:12 PM	8/26/2021, 4:02:57 PM	1h 17m	araught@agora.org	Presenter	araught@agora.org
Cathryn Mack	8/26/2021, 2:45:16 PM	8/26/2021, 3:43:26 PM	58m 9s	cmack@agora.org	Presenter	cmack@agora.org
Melissa Gaso	8/26/2021, 2:45:18 PM	8/26/2021, 3:43:25 PM	58m 7s	mgaso@agora.org	Presenter	mgaso@agora.org
Joseph Passante	8/26/2021, 2:45:21 PM	8/26/2021, 3:48:21 PM	1h 2m	jpassante@agora.org	Presenter	jpassante@agora.org
Janet Ulewicz	8/26/2021, 2:45:23 PM	8/26/2021, 3:43:24 PM	58m 1s	julewicz@agora.org	Presenter	julewicz@agora.org
Justin Groshon	8/26/2021, 2:45:24 PM	8/26/2021, 3:46:12 PM	1h	jgroshon@agora.org	Presenter	jgroshon@agora.org
Judy Deemer	8/26/2021, 2:45:26 PM	8/26/2021, 3:43:29 PM	58m 3s	jdeemer@agora.org	Presenter	jdeemer@agora.org
Samantha Bonniger	8/26/2021, 2:46:14 PM	8/26/2021, 3:43:51 PM	57m 36s	sbonniger@agora.org	Presenter	sbonniger@agora.org
Heather Silberman	8/26/2021, 2:47:14 PM	8/26/2021, 3:43:24 PM	56m 9s	hsilberman@agora.org	Presenter	hsilberman@agora.org
Theresa Bash	8/26/2021, 2:48:27 PM	8/26/2021, 3:43:24 PM	54m 56s	tbash@agora.org	Presenter	tbash@agora.org
Susan Lelko	8/26/2021, 2:48:29 PM	8/26/2021, 3:43:28 PM	54m 59s	slelko@agora.org	Presenter	slelko@agora.org
Jennifer Flatley	8/26/2021, 2:49:23 PM	8/26/2021, 3:43:22 PM	53m 58s	jflatley@agora.org	Presenter	jflatley@agora.org
Jodeen Buckwalter	8/26/2021, 2:49:27 PM	8/26/2021, 3:07:46 PM	18m 18s	jbuckwalter@agora.org	Presenter	jbuckwalter@agora.org
Tracey Ambuka	8/26/2021, 2:49:40 PM	8/26/2021, 3:43:40 PM	54m	tambuka@agora.org	Presenter	tambuka@agora.org
Katie O'Donnell	8/26/2021, 2:51:09 PM	8/26/2021, 3:46:20 PM	55m 11s	kodonnell@agora.org	Presenter	kodonnell@agora.org
Lisa Savitz	8/26/2021, 2:52:21 PM	8/26/2021, 3:43:42 PM	51m 20s	lsavitz@agora.org	Presenter	lsavitz@agora.org
Kaelyn Hoffman	8/26/2021, 2:52:23 PM	8/26/2021, 3:43:36 PM	51m 12s	khoffman@agora.org	Presenter	khoffman@agora.org
Amanda Armstrong	8/26/2021, 2:52:42 PM	8/26/2021, 3:43:41 PM	50m 58s	aarmstrong@agora.org	Presenter	aarmstrong@agora.org
Sarah Pittman	8/26/2021, 2:52:51 PM	8/26/2021, 3:43:30 PM	50m 38s	spittman@agora.org	Presenter	spittman@agora.org
Kristal Costanzo	8/26/2021, 2:53:06 PM	8/26/2021, 3:43:39 PM	50m 32s	kcostanzo@agora.org	Presenter	kcostanzo@agora.org
Kimberly Paolino	8/26/2021, 2:53:11 PM	8/26/2021, 3:43:24 PM	50m 13s	kpaolino@agora.org	Presenter	kpaolino@agora.org
Lauren Lamison	8/26/2021, 2:53:13 PM	8/26/2021, 3:43:22 PM	50m 8s	llamison@agora.org	Presenter	llamison@agora.org
Allison Large	8/26/2021, 2:53:18 PM	8/26/2021, 3:43:29 PM	50m 11s	alarge@agora.org	Presenter	alarge@agora.org
Amber Brisbane	8/26/2021, 2:53:32 PM	8/26/2021, 3:43:24 PM	49m 51s	abrisbane@agora.org	Presenter	abrisbane@agora.org



Marlee Atwood	8/26/2021, 2:53:38 PM	8/26/2021, 3:43:28 PM	49m 50s	matwood@agora.org	Presenter	matwood@agora.org
Carmen Riggie	8/26/2021, 2:53:50 PM	8/26/2021, 3:43:22 PM	49m 32s	criggie@agora.org	Presenter	criggie@agora.org
Lauren Kerns	8/26/2021, 2:53:54 PM	8/26/2021, 3:43:34 PM	49m 39s	lkerns@agora.org	Presenter	lkerns@agora.org
Rachel Carmichael	8/26/2021, 2:54:04 PM	8/26/2021, 3:43:50 PM	49m 45s	rcarmichael@agora.org	Presenter	rcarmichael@agora.org
Regina Kubica	8/26/2021, 2:54:09 PM	8/26/2021, 3:43:27 PM	49m 17s	rkubica@agora.org	Presenter	rkubica@agora.org
Susan Lipiec	8/26/2021, 2:54:22 PM	8/26/2021, 3:45:42 PM	51m 19s	slipiec@agora.org	Presenter	slipiec@agora.org
Melissa Love	8/26/2021, 2:54:28 PM	8/26/2021, 3:43:24 PM	48m 55s	mlove@agora.org	Presenter	mlove@agora.org
Amanda Moyer	8/26/2021, 2:54:45 PM	8/26/2021, 3:43:43 PM	48m 57s	amoyer@agora.org	Presenter	amoyer@agora.org
Laura Stapf	8/26/2021, 2:55:18 PM	8/26/2021, 3:43:36 PM	48m 17s	lstapf@agora.org	Presenter	lstapf@agora.org
Jennifer Beeken	8/26/2021, 2:55:18 PM	8/26/2021, 3:43:40 PM	48m 22s	jbeeken@agora.org	Presenter	jbeeken@agora.org
Veronica Jackson	8/26/2021, 2:55:22 PM	8/26/2021, 3:45:07 PM	49m 45s	vjackson@agora.org	Presenter	vjackson@agora.org
Jill Moyer	8/26/2021, 2:55:26 PM	8/26/2021, 3:43:33 PM	48m 6s	jmoyer2@agora.org	Presenter	jmoyer2@agora.org
Regina Mallon	8/26/2021, 2:55:37 PM	8/26/2021, 3:43:29 PM	47m 51s	gmallon@agora.org	Presenter	gmallon@agora.org
Janelle Shaffer	8/26/2021, 2:55:38 PM	8/26/2021, 3:43:37 PM	47m 59s	jshaffer3@agora.org	Presenter	jshaffer3@agora.org
Melissa Stump	8/26/2021, 2:55:39 PM	8/26/2021, 3:43:24 PM	47m 44s	mstump@agora.org	Presenter	mstump@agora.org
Terri Hunkele	8/26/2021, 2:55:42 PM	8/26/2021, 3:43:40 PM	47m 57s	thunkele@agora.org	Presenter	thunkele@agora.org
Shari Widlund	8/26/2021, 2:55:43 PM	8/26/2021, 3:43:23 PM	47m 39s	swidlund@agora.org	Presenter	swidlund@agora.org
Keri Shannon	8/26/2021, 2:55:44 PM	8/26/2021, 3:43:35 PM	47m 51s	kshannon@agora.org	Presenter	kshannon@agora.org
Heather Gallagher	8/26/2021, 2:55:46 PM	8/26/2021, 3:43:43 PM	47m 56s	hgallagher@agora.org	Presenter	hgallagher@agora.org
Jenna Lee Dietrich	8/26/2021, 2:55:53 PM	8/26/2021, 3:43:24 PM	47m 30s	jdietrich@agora.org	Presenter	jdietrich@agora.org
Tamara Kozak	8/26/2021, 2:56:06 PM	8/26/2021, 3:43:34 PM	47m 27s	tkozak@agora.org	Presenter	tkozak@agora.org
Danielle Pricer	8/26/2021, 2:56:07 PM	8/26/2021, 3:43:58 PM	47m 51s	dpricer@agora.org	Presenter	dpricer@agora.org
Rebekah Congdon	8/26/2021, 2:56:19 PM	8/26/2021, 3:43:21 PM	47m 2s	rcongdon@agora.org	Presenter	rcongdon@agora.org
Shannon Feeney Hoffmaster	8/26/2021, 2:56:30 PM	8/26/2021, 3:43:27 PM	46m 56s	shoffmaster@agora.org	Presenter	shoffmaster@agora.org
Ashley Schmidt	8/26/2021, 2:56:37 PM	8/26/2021, 3:43:20 PM	46m 42s	aschmidt@agora.org	Presenter	aschmidt@agora.org
Kristina Lapsker	8/26/2021, 2:56:38 PM	8/26/2021, 3:43:23 PM	46m 45s	klapsker@agora.org	Presenter	klapsker@agora.org
Serena Adams	8/26/2021, 2:56:43 PM	8/26/2021, 3:43:26 PM	46m 42s	sadams@agora.org	Presenter	sadams@agora.org
Theresa Draeger	8/26/2021, 2:56:49 PM	8/26/2021, 3:45:03 PM	48m 14s	tdraeger@agora.org	Presenter	tdraeger@agora.org
Melissa Hale-Patterson	8/26/2021, 2:56:49 PM	8/26/2021, 3:43:40 PM	46m 50s	mpatterson@agora.org	Presenter	mpatterson@agora.org
Joy Fegely	8/26/2021, 2:56:52 PM	8/26/2021, 3:43:23 PM	46m 30s	jfegely@agora.org	Presenter	jfegely@agora.org
Jennifer Buss	8/26/2021, 2:56:57 PM	8/26/2021, 3:43:29 PM	46m 32s	jbuss@agora.org	Presenter	jbuss@agora.org
Jessica Barnhart	8/26/2021, 2:57:08 PM	8/26/2021, 3:43:41 PM	46m 33s	jbarnhart@agora.org	Presenter	jbarnhart@agora.org
Brett Stevens	8/26/2021, 2:57:17 PM	8/26/2021, 3:43:26 PM	46m 8s	bstevens2@agora.org	Presenter	bstevens2@agora.org
Jennifer Zollman	8/26/2021, 2:57:17 PM	8/26/2021, 3:43:34 PM	46m 16s	jzollman@agora.org	Presenter	jzollman@agora.org

Shelley Stump	8/26/2021, 2:57:18 PM	8/26/2021, 3:43:28 PM	46m 9s	sstump@agora.org	Presenter	sstump@agora.org
Brittany Froehlich	8/26/2021, 2:57:30 PM	8/26/2021, 3:43:23 PM	45m 52s	BFroehlich@agora.org	Presenter	BFroehlich@agora.org
Laurie Super	8/26/2021, 2:57:31 PM	8/26/2021, 3:43:40 PM	46m 8s	lsuper@agora.org	Presenter	lsuper@agora.org
Morgan Witman	8/26/2021, 2:57:32 PM	8/26/2021, 3:43:26 PM	45m 53s	mwitman@agora.org	Presenter	mwitman@agora.org
Stacy Vietmeier	8/26/2021, 2:57:57 PM	8/26/2021, 3:43:35 PM	45m 37s	svietmeier@agora.org	Presenter	svietmeier@agora.org
Amber Staley	8/26/2021, 2:57:59 PM	8/26/2021, 3:43:34 PM	45m 34s	astaley2@agora.org	Presenter	astaley2@agora.org
Sasha Young	8/26/2021, 2:58:03 PM	8/26/2021, 3:43:33 PM	45m 29s	syoung@agora.org	Presenter	syoung@agora.org
Ashley Farster	8/26/2021, 2:58:09 PM	8/26/2021, 3:43:33 PM	45m 23s	afarster@agora.org	Presenter	afarster@agora.org
Kimberly McLaughlin	8/26/2021, 2:58:10 PM	8/26/2021, 3:49:09 PM	50m 58s	kmclaughlin@agora.org	Presenter	kmclaughlin@agora.org
Chris Baker	8/26/2021, 2:58:12 PM	8/26/2021, 3:02:58 PM	4m 46s	cbaker@agora.org	Presenter	cbaker@agora.org
Chris Baker	8/26/2021, 3:04:43 PM	8/26/2021, 3:43:32 PM	38m 49s	cbaker@agora.org	Presenter	cbaker@agora.org
Colien Byers	8/26/2021, 2:58:19 PM	8/26/2021, 3:43:40 PM	45m 20s	cbyers@agora.org	Presenter	cbyers@agora.org
Brianna Pontious	8/26/2021, 2:58:20 PM	8/26/2021, 3:43:31 PM	45m 11s	bpontious@agora.org	Presenter	bpontious@agora.org
Ashley Salimbene	8/26/2021, 2:58:20 PM	8/26/2021, 3:43:26 PM	45m 6s	asalimbene@agora.org	Presenter	asalimbene@agora.org
Molly Garczynski	8/26/2021, 2:58:24 PM	8/26/2021, 3:43:32 PM	45m 7s	mgarczynski@agora.org	Presenter	mgarczynski@agora.org
Valerie Natale	8/26/2021, 2:58:26 PM	8/26/2021, 3:16:12 PM	17m 45s	vnatale@agora.org	Presenter	vnatale@agora.org
Valerie Natale	8/26/2021, 3:17:18 PM	8/26/2021, 3:43:35 PM	26m 16s	vnatale@agora.org	Presenter	vnatale@agora.org
Jennifer DePietro	8/26/2021, 2:58:27 PM	8/26/2021, 3:43:35 PM	45m 7s	jdepietro@agora.org	Presenter	jdepietro@agora.org
Kayla Flores	8/26/2021, 2:58:31 PM	8/26/2021, 3:43:46 PM	45m 15s	kflores@agora.org	Presenter	kflores@agora.org
Kattreena Amodeo	8/26/2021, 2:58:40 PM	8/26/2021, 3:43:29 PM	44m 48s	kamodeo@agora.org	Presenter	kamodeo@agora.org
Gemma Mattox	8/26/2021, 2:58:42 PM	8/26/2021, 3:43:32 PM	44m 49s	gmattox@agora.org	Presenter	gmattox@agora.org
Lauren Svonavec	8/26/2021, 2:58:47 PM	8/26/2021, 3:43:22 PM	44m 35s	lsvonavec@agora.org	Presenter	lsvonavec@agora.org
Sabrina Kennedy	8/26/2021, 2:58:49 PM	8/26/2021, 3:43:31 PM	44m 41s	skennedy@agora.org	Presenter	skennedy@agora.org
Angela Denham	8/26/2021, 2:58:51 PM	8/26/2021, 3:43:29 PM	44m 37s	adenham@agora.org	Presenter	adenham@agora.org
Cathryn Ramsey	8/26/2021, 2:59:06 PM	8/26/2021, 3:43:21 PM	44m 14s	cramsey@agora.org	Presenter	cramsey@agora.org
Cathrine Hartman	8/26/2021, 2:59:08 PM	8/26/2021, 3:43:38 PM	44m 30s	chartman@agora.org	Presenter	chartman@agora.org
Jennifer McGinty	8/26/2021, 2:59:18 PM	8/26/2021, 3:43:30 PM	44m 11s	jmcginty@agora.org	Presenter	jmcginty@agora.org
Whitney Bargerstock	8/26/2021, 2:59:23 PM	8/26/2021, 3:43:52 PM	44m 28s	wbargerstock@agora.org	Presenter	wbargerstock@agora.org
Breanne Scears	8/26/2021, 2:59:25 PM	8/26/2021, 3:43:41 PM	44m 15s	bscears@agora.org	Presenter	bscears@agora.org
Erin Connor	8/26/2021, 2:59:27 PM	8/26/2021, 3:43:25 PM	43m 58s	econnor@agora.org	Presenter	econnor@agora.org
Erinn Slacktish	8/26/2021, 2:59:27 PM	8/26/2021, 3:43:25 PM	43m 57s	eslacktish@agora.org	Presenter	eslacktish@agora.org
Rachel Weeks	8/26/2021, 2:59:28 PM	8/26/2021, 3:43:22 PM	43m 54s	rweeks@agora.org	Presenter	rweeks@agora.org
Jesse Capitano	8/26/2021, 2:59:31 PM	8/26/2021, 3:43:35 PM	44m 4s	jcapitano@agora.org	Presenter	jcapitano@agora.org
Maria Harlan	8/26/2021, 2:59:32 PM	8/26/2021, 3:43:37 PM	44m 4s	mharlan@agora.org	Presenter	mharlan@agora.org

Amirah McIntyre	8/26/2021, 2:59:33 PM	8/26/2021, 3:27:10 PM	27m 36s	amcintyre@agora.org	Presenter	amcintyre@agora.org
Amirah McIntyre	8/26/2021, 3:28:43 PM	8/26/2021, 3:28:44 PM	1s	amcintyre@agora.org	Presenter	amcintyre@agora.org
Amirah McIntyre	8/26/2021, 3:32:41 PM	8/26/2021, 3:43:26 PM	10m 44s	amcintyre@agora.org	Presenter	amcintyre@agora.org
Bridget Ellis	8/26/2021, 2:59:33 PM	8/26/2021, 3:43:28 PM	43m 54s	bellis@agora.org	Presenter	bellis@agora.org
Danielle Schall	8/26/2021, 2:59:36 PM	8/26/2021, 3:43:41 PM	44m 4s	dschall@agora.org	Presenter	dschall@agora.org
Brittany Kieffer	8/26/2021, 2:59:37 PM	8/26/2021, 3:43:30 PM	43m 53s	bkieffer@agora.org	Presenter	bkieffer@agora.org
Carissa Emrick	8/26/2021, 2:59:40 PM	8/26/2021, 3:44:01 PM	44m 20s	cemrick@agora.org	Presenter	cemrick@agora.org
Heidi Dodge	8/26/2021, 2:59:42 PM	8/26/2021, 3:43:38 PM	43m 55s	hdodge@agora.org	Presenter	hdodge@agora.org
Jena Huffman	8/26/2021, 2:59:49 PM	8/26/2021, 3:43:28 PM	43m 38s	jhuffman@agora.org	Presenter	jhuffman@agora.org
Maura Basso	8/26/2021, 2:59:49 PM	8/26/2021, 3:38:20 PM	38m 30s	mbasso@agora.org	Presenter	mbasso@agora.org
Jessica Linderman	8/26/2021, 2:59:53 PM	8/26/2021, 3:43:39 PM	43m 46s	jlinderman@agora.org	Presenter	jlinderman@agora.org
Barry Sigal	8/26/2021, 2:59:53 PM	8/26/2021, 3:29:04 PM	29m 10s	bsigal@agora.org	Presenter	bsigal@agora.org
Leslie Spratt	8/26/2021, 2:59:54 PM	8/26/2021, 3:43:37 PM	43m 43s	lspratt@agora.org	Presenter	lspratt@agora.org
Lynn Pagliei	8/26/2021, 2:59:55 PM	8/26/2021, 3:43:19 PM	43m 23s	lpagliei@agora.org	Presenter	lpagliei@agora.org
Jennifer Cadieux	8/26/2021, 2:59:56 PM	8/26/2021, 3:43:38 PM	43m 42s	jcadieux@agora.org	Presenter	jcadieux@agora.org
Dana Pacolay	8/26/2021, 3:00:01 PM	8/26/2021, 3:43:47 PM	43m 46s	dpacolay@agora.org	Presenter	dpacolay@agora.org
Nancy Reimers	8/26/2021, 3:00:08 PM	8/26/2021, 3:43:41 PM	43m 33s	nreimers@agora.org	Presenter	nreimers@agora.org
Karen Siwik	8/26/2021, 3:00:09 PM	8/26/2021, 3:27:24 PM	27m 15s	ksiwik@agora.org	Presenter	ksiwik@agora.org
Olivia Eckels	8/26/2021, 3:00:09 PM	8/26/2021, 3:43:40 PM	43m 31s	oeckels@agora.org	Presenter	oeckels@agora.org
Kymerly Humanick	8/26/2021, 3:00:27 PM	8/26/2021, 3:32:54 PM	32m 27s	khumanick@agora.org	Presenter	khumanick@agora.org
Kimberly Fiscus	8/26/2021, 3:00:29 PM	8/26/2021, 3:43:30 PM	43m 1s	kfiscus@agora.org	Presenter	kfiscus@agora.org
Lisa Brestensky	8/26/2021, 3:00:33 PM	8/26/2021, 3:45:25 PM	44m 52s	lbrestensky@agora.org	Presenter	lbrestensky@agora.org
Anna Lepsch	8/26/2021, 3:00:34 PM	8/26/2021, 3:43:29 PM	42m 55s	alepsch@agora.org	Presenter	alepsch@agora.org
Casey Chaffin	8/26/2021, 3:00:36 PM	8/26/2021, 3:43:31 PM	42m 55s	cchaffin@agora.org	Presenter	cchaffin@agora.org
Brittany Reamer	8/26/2021, 3:00:38 PM	8/26/2021, 3:43:23 PM	42m 44s	breamer@agora.org	Presenter	breamer@agora.org
Chelsey Panchura	8/26/2021, 3:00:40 PM	8/26/2021, 3:43:39 PM	42m 59s	cpanchura@agora.org	Presenter	cpanchura@agora.org
Renee Perri	8/26/2021, 3:00:41 PM	8/26/2021, 3:43:29 PM	42m 47s	rperri@agora.org	Presenter	rperri@agora.org
Nicole Krol	8/26/2021, 3:00:45 PM	8/26/2021, 3:43:32 PM	42m 46s	nkrol@agora.org	Presenter	nkrol@agora.org
Melissa McCracken	8/26/2021, 3:00:51 PM	8/26/2021, 3:43:25 PM	42m 34s	mmccracken@agora.org	Presenter	mmccracken@agora.org
Jill Severino	8/26/2021, 3:01:27 PM	8/26/2021, 3:43:45 PM	42m 17s	jseverino@agora.org	Presenter	jseverino@agora.org
Erin Scrip	8/26/2021, 3:01:50 PM	8/26/2021, 3:51:52 PM	50m 1s	escrip@agora.org	Presenter	escrip@agora.org
Jen Lucia	8/26/2021, 3:02:21 PM	8/26/2021, 3:44:04 PM	41m 42s	jlucia@agora.org	Presenter	jlucia@agora.org
Colleen Freyvogel Bruss	8/26/2021, 3:02:35 PM	8/26/2021, 3:43:39 PM	41m 4s	cfreyvogel@agora.org	Presenter	cfreyvogel@agora.org
Cortney Barkley	8/26/2021, 3:02:58 PM	8/26/2021, 3:44:00 PM	41m 2s	cbarkley@agora.org	Presenter	cbarkley@agora.org

Patrick Lavelle	8/26/2021, 3:03:29 PM	8/26/2021, 3:47:03 PM	43m 33s	plavelle@agora.org	Presenter	plavelle@agora.org
Anna Baranoski	8/26/2021, 3:04:46 PM	8/26/2021, 3:43:40 PM	38m 54s	abaranoski@agora.org	Presenter	abaranoski@agora.org
Amanda Kammermeier	8/26/2021, 3:04:53 PM	8/26/2021, 3:43:47 PM	38m 54s	akammermeier@agora.org	Presenter	akammermeier@agora.org
Melissa Franklin	8/26/2021, 3:05:09 PM	8/26/2021, 3:43:34 PM	38m 24s	mfranklin@agora.org	Presenter	mfranklin@agora.org
Gina Rodriguez	8/26/2021, 3:05:18 PM	8/26/2021, 3:43:40 PM	38m 21s	grodriguez@agora.org	Presenter	grodriguez@agora.org
Lauren Radico	8/26/2021, 3:05:24 PM	8/26/2021, 3:44:24 PM	38m 59s	lradico@agora.org	Presenter	lradico@agora.org
Barb Cooper	8/26/2021, 3:05:44 PM	8/26/2021, 3:43:23 PM	37m 38s	bcooper@agora.org	Presenter	bcooper@agora.org
Tara Walker	8/26/2021, 3:05:55 PM	8/26/2021, 3:43:33 PM	37m 37s	twalker@agora.org	Presenter	twalker@agora.org
Gillian Kaufman	8/26/2021, 3:06:10 PM	8/26/2021, 3:43:28 PM	37m 17s	gkaufman@agora.org	Presenter	gkaufman@agora.org
Dana O'Donnell	8/26/2021, 3:06:19 PM	8/26/2021, 3:47:00 PM	40m 40s	Dodonnell@agora.org	Presenter	Dodonnell@agora.org
David Furka	8/26/2021, 3:06:25 PM	8/26/2021, 3:43:39 PM	37m 13s	dfurka@agora.org	Presenter	dfurka@agora.org
Kelly Berstecher	8/26/2021, 3:06:33 PM	8/26/2021, 3:43:38 PM	37m 4s	kberstecher@agora.org	Presenter	kberstecher@agora.org
Julie Doebereiner	8/26/2021, 3:12:06 PM	8/26/2021, 3:43:24 PM	31m 18s	jdoebereiner@agora.org	Presenter	jdoebereiner@agora.org



# 504 Overview Objectives

- Identify the difference between IDEA and 504
- Summarize the 504 Process at Agora
- Locate 504 program alerts and student documents in Tyler SIS
- Identify what steps to take if a student is transitioning between a 504 service agreement and special education



1. Summary						
Attended participants		34				
Start time	8/26/21, 1:25:35 PM					
End time	8/26/21, 2:45:08 PM					
Meeting duration	1h 19m 33s					
Average attendance time	56m 25s					
2. Participants						
Name	First join	Last leave	In-meeting duration	Email	Participant ID (UPN)	Role
Ryan Learn	8/26/21, 1:25:44 PM	8/26/21, 2:33:07 PM	1h 7m 23s	rlearn@agora.org	rlearn@agora.org	Presenter
Justin Groshon	8/26/21, 1:26:00 PM	8/26/21, 2:45:08 PM	1h 17m 39s	jgroshon@agora.org	jgroshon@agora.org	Presenter
Roxanne Zeisloft	8/26/21, 1:26:52 PM	8/26/21, 2:33:07 PM	1h 6m 14s	rzeisloft@agora.org	rzeisloft@agora.org	Presenter
Tara Quisito	8/26/21, 1:27:14 PM	8/26/21, 2:33:09 PM	1h 4m 42s	tquisito@agora.org	tquisito@agora.org	Presenter
Stephanie Shivetts	8/26/21, 1:27:22 PM	8/26/21, 2:33:10 PM	1h 5m 48s	sshivetts@agora.org	sshivetts@agora.org	Presenter
Danielle Ambrose	8/26/21, 1:27:37 PM	8/26/21, 2:33:04 PM	1h 5m 26s	dambrose@agora.org	dambrose@agora.org	Presenter
Mia Jafarian	8/26/21, 1:27:43 PM	8/26/21, 2:18:15 PM	50m 32s	MJafarian@agora.org	MJafarian@agora.org	Presenter
Morgan Witman	8/26/21, 1:27:45 PM	8/26/21, 2:33:33 PM	1h 4m 17s	mwitman@agora.org	mwitman@agora.org	Organizer
Pamela Zakielarz	8/26/21, 1:27:45 PM	8/26/21, 2:33:04 PM	1h 5m 18s	pzakielarz@agora.org	pzakielarz@agora.org	Presenter
Danielle Pricer	8/26/21, 1:27:52 PM	8/26/21, 2:33:14 PM	1h 5m 21s	dpricer@agora.org	dpricer@agora.org	Presenter
Kelly Noss	8/26/21, 1:28:00 PM	8/26/21, 2:33:15 PM	1h 5m 14s	knoss@agora.org	knoss@agora.org	Presenter
Barron Whited	8/26/21, 1:28:12 PM	8/26/21, 2:33:09 PM	1h 4m 57s	bwhited@agora.org	bwhited@agora.org	Presenter
Suzanne Klein	8/26/21, 1:28:18 PM	8/26/21, 2:33:04 PM	1h 4m 46s	sklein@agora.org	sklein@agora.org	Presenter
Erica Lee	8/26/21, 1:28:23 PM	8/26/21, 2:33:06 PM	1h 4m 42s	elee@agora.org	elee@agora.org	Presenter
Amy Shea	8/26/21, 1:28:26 PM	8/26/21, 2:33:10 PM	1h 4m 43s	ashea@agora.org	ashea@agora.org	Presenter
Laura Manko	8/26/21, 1:28:27 PM	8/26/21, 2:27:44 PM	59m 17s	lmanko@agora.org	lmanko@agora.org	Presenter
Mindy Rockower	8/26/21, 1:29:16 PM	8/26/21, 2:33:05 PM	1h 2m 10s	mrockower@agora.org	mrockower@agora.org	Presenter
Amy Shehan	8/26/21, 1:29:37 PM	8/26/21, 2:33:25 PM	1h 3m 48s	ashehan@agora.org	ashehan@agora.org	Presenter
Elena Laubach	8/26/21, 1:29:38 PM	8/26/21, 2:33:06 PM	1h 3m 28s	elaubach@agora.org	elaubach@agora.org	Presenter
Eileen Nelson	8/26/21, 1:29:39 PM	8/26/21, 2:33:12 PM	1h 3m 32s	enelson@agora.org	enelson@agora.org	Presenter
Brittany Kieffer	8/26/21, 1:29:43 PM	8/26/21, 2:33:07 PM	1h 3m 23s	bkieffer@agora.org	bkieffer@agora.org	Presenter
Tim Kreider	8/26/21, 1:29:45 PM	8/26/21, 2:33:23 PM	1h 3m 37s	tkreider@agora.org	tkreider@agora.org	Presenter
Lauren Stenson	8/26/21, 1:29:46 PM	8/26/21, 2:33:05 PM	1h 3m 18s	lstenson@agora.org	lstenson@agora.org	Presenter
Mike Mirth	8/26/21, 1:29:51 PM	8/26/21, 2:33:07 PM	1h 3m 16s	mmirth@agora.org	mmirth@agora.org	Presenter
Shelley Stump	8/26/21, 1:29:52 PM	8/26/21, 2:33:09 PM	1h 3m 17s	sstump@agora.org	sstump@agora.org	Presenter

# Meeting Agenda

- Advisory
- General Information
- Schedule
- Asynchronous Expectations
- Baseline and Progress Monitoring
- PLC
- Input Forms
- Lesson Plans
- Supplemental Programs
- Interventions
- Walkthroughs and Observations





# Our Academic Resource Room Team

Resource Room Teacher	Resource Room
JoDeen Buckwalter	Reading RR B & C
Nancy Reimers	Reading RR C & D
Katie O'Donnell	Reading RR D
Barb Cooper	Writing RR B & C
Tara Walker	Writing RR C & D
Mandi Moyer	Math RR B
Veronica Jackson	Math RR C & D
Jill Moyer	Math RR C
Jennifer Flatley	Math RR D

**Instructional Coach**

**Michelle Olsavsky**



Erinn Slacktish	8/26/21, 1:30:08 PM	8/26/21, 2:00:10 PM	30m 1s	eslacktish@agora.org	eslacktish@agora.org	Presenter
Fallon Nicholas	8/26/21, 1:30:39 PM	8/26/21, 2:33:15 PM	1h 2m 35s	fnicholas@agora.org	fnicholas@agora.org	Presenter
Jennifer Fisher Clark	8/26/21, 1:31:34 PM	8/26/21, 2:00:25 PM	28m 50s	jclark@agora.org	jclark@agora.org	Presenter
Mindy Wesley	8/26/21, 1:32:43 PM	8/26/21, 2:10:50 PM	38m 7s	mwesley@agora.org	mwesley@agora.org	Presenter
Jennifer McGinty	8/26/21, 1:34:55 PM	8/26/21, 2:32:13 PM	57m 18s	jmcginty@agora.org	jmcginty@agora.org	Presenter
Kayla Flores	8/26/21, 1:39:37 PM	8/26/21, 2:34:57 PM	55m 20s	kflores@agora.org	kflores@agora.org	Presenter
Kimberly McLaughlin	8/26/21, 1:54:17 PM	8/26/21, 2:32:53 PM	38m 36s	kmclaughlin@agora.org	kmclaughlin@agora.org	Presenter
16102302980	8/26/21, 2:00:39 PM	8/26/21, 2:00:43 PM	3s			Attendee
16102302716	8/26/21, 2:09:02 PM	8/26/21, 2:10:39 PM	1m 36s			Attendee
3. In-Meeting activities						
Name	Join time	Leave time	Duration	Email	Role	
Ryan Learn	8/26/21, 1:25:44 PM	8/26/21, 2:33:07 PM	1h 7m 23s	rlearn@agora.org	Presenter	
Justin Groshon	8/26/21, 1:26:00 PM	8/26/21, 1:27:49 PM	1m 49s	jgroshon@agora.org	Presenter	
Justin Groshon	8/26/21, 1:29:17 PM	8/26/21, 2:45:08 PM	1h 15m 50s	jgroshon@agora.org	Presenter	
Roxanne Zeisloft	8/26/21, 1:26:52 PM	8/26/21, 2:33:07 PM	1h 6m 14s	rzeisloft@agora.org	Presenter	
Tara Quisito	8/26/21, 1:27:14 PM	8/26/21, 1:40:55 PM	13m 40s	tquisito@agora.org	Presenter	
Tara Quisito	8/26/21, 1:42:06 PM	8/26/21, 2:33:09 PM	51m 2s	tquisito@agora.org	Presenter	
Stephanie Shivetts	8/26/21, 1:27:22 PM	8/26/21, 2:33:10 PM	1h 5m 48s	sshivetts@agora.org	Presenter	
Danielle Ambrose	8/26/21, 1:27:37 PM	8/26/21, 2:33:04 PM	1h 5m 26s	dambrose@agora.org	Presenter	
Mia Jafarian	8/26/21, 1:27:43 PM	8/26/21, 2:18:15 PM	50m 32s	MJafarian@agora.org	Presenter	
Morgan Witman	8/26/21, 1:27:45 PM	8/26/21, 1:59:58 PM	32m 13s	mwitman@agora.org	Organizer	
Morgan Witman	8/26/21, 2:01:28 PM	8/26/21, 2:33:33 PM	32m 4s	mwitman@agora.org	Organizer	
Pamela Zakielarz	8/26/21, 1:27:45 PM	8/26/21, 2:33:04 PM	1h 5m 18s	pzakielarz@agora.org	Presenter	
Danielle Pricer	8/26/21, 1:27:52 PM	8/26/21, 2:33:14 PM	1h 5m 21s	dpricer@agora.org	Presenter	
Kelly Noss	8/26/21, 1:28:00 PM	8/26/21, 2:33:15 PM	1h 5m 14s	knoss@agora.org	Presenter	
Barron Whited	8/26/21, 1:28:12 PM	8/26/21, 2:33:09 PM	1h 4m 57s	bwhited@agora.org	Presenter	
Suzanne Klein	8/26/21, 1:28:18 PM	8/26/21, 2:33:04 PM	1h 4m 46s	sklein@agora.org	Presenter	
Erica Lee	8/26/21, 1:28:23 PM	8/26/21, 2:33:06 PM	1h 4m 42s	elee@agora.org	Presenter	
Amy Shea	8/26/21, 1:28:26 PM	8/26/21, 2:33:10 PM	1h 4m 43s	ashea@agora.org	Presenter	
Laura Manko	8/26/21, 1:28:27 PM	8/26/21, 2:27:44 PM	59m 17s	lmanko@agora.org	Presenter	
Mindy Rockower	8/26/21, 1:29:16 PM	8/26/21, 1:40:19 PM	11m 2s	mrockower@agora.org	Presenter	
Mindy Rockower	8/26/21, 1:41:56 PM	8/26/21, 2:33:05 PM	51m 8s	mrockower@agora.org	Presenter	
Amy Shehan	8/26/21, 1:29:37 PM	8/26/21, 2:33:25 PM	1h 3m 48s	ashehan@agora.org	Presenter	

Elena Laubach	8/26/21, 1:29:38 PM	8/26/21, 2:33:06 PM	1h 3m 28s	elaubach@agora.org	Presenter	
Eileen Nelson	8/26/21, 1:29:39 PM	8/26/21, 2:33:12 PM	1h 3m 32s	enelson@agora.org	Presenter	
Brittany Kieffer	8/26/21, 1:29:43 PM	8/26/21, 2:33:07 PM	1h 3m 23s	bkieffer@agora.org	Presenter	
Tim Kreider	8/26/21, 1:29:45 PM	8/26/21, 2:33:23 PM	1h 3m 37s	tkreider@agora.org	Presenter	
Lauren Stenson	8/26/21, 1:29:46 PM	8/26/21, 2:33:05 PM	1h 3m 18s	lstenson@agora.org	Presenter	
Mike Mirth	8/26/21, 1:29:51 PM	8/26/21, 2:33:07 PM	1h 3m 16s	mmirth@agora.org	Presenter	
Shelley Stump	8/26/21, 1:29:52 PM	8/26/21, 2:33:09 PM	1h 3m 17s	sstump@agora.org	Presenter	
Erinn Slacktish	8/26/21, 1:30:08 PM	8/26/21, 2:00:10 PM	30m 1s	eslacktish@agora.org	Presenter	
Fallon Nicholas	8/26/21, 1:30:39 PM	8/26/21, 2:33:15 PM	1h 2m 35s	fnicholas@agora.org	Presenter	
Jennifer Fisher Clark	8/26/21, 1:31:34 PM	8/26/21, 2:00:25 PM	28m 50s	jclark@agora.org	Presenter	
Mindy Wesley	8/26/21, 1:32:43 PM	8/26/21, 2:10:50 PM	38m 7s	mwesley@agora.org	Presenter	
Jennifer McGinty	8/26/21, 1:34:55 PM	8/26/21, 2:32:13 PM	57m 18s	jmcginty@agora.org	Presenter	
Kayla Flores	8/26/21, 1:39:37 PM	8/26/21, 2:34:57 PM	55m 20s	kflores@agora.org	Presenter	
Kimberly McLaughlin	8/26/21, 1:54:17 PM	8/26/21, 2:32:53 PM	38m 36s	kmclaughlin@agora.org	Presenter	
16102302980	8/26/21, 2:00:39 PM	8/26/21, 2:00:43 PM	3s		Attendee	
16102302716	8/26/21, 2:09:02 PM	8/26/21, 2:10:39 PM	1m 36s		Attendee	

# Meeting Agenda

- Our Team
- Team Expectations
- Professionalism
- Team Meetings & PLC
- PTO
- Differentiated Supervision
- Advisory Welcome Calls
- General Ed. Odds and Ends
- Student Assembly Info
- Reminders
- Have a fabulous week!



## Danielle & Michelle

Teacher	Role
JoDeen Buckwalter	Reading B/C
Nancy Reimers	Reading C/D
Katie O'Donnell	Reading D
Amanda Mover	Math B
Veronica Jackson	Math C/D
Jill Mover	Math C
Jennifer Flatley	Math D
Barb Cooper	Writing B/C
Tara Walker	Writing C/D
Sasha Youna	LS & 1:1
Allison Sweeney	1-2 LS CM
Sue Lelko	1-2 LS CM
Keri Shannon	1-2 LS CM
Heather Silberman	1-2 LS CM
Jennifer Zollman	1-2 LS CM
Melissa Love	3A&B LS CM
Lynn Paaliej	3A&B LS CM
Becky Conadon	3A&B LS CM
Terri Hunkele	3A&B LS CM
Theresa Draeaer	3A&B LS CM
Lisa Savitz	3A&B LS CM
Kattreena Omodeo	3A&B LS CM
NEW LS Case Manager	1-3B LS CM

# MEET OUR TEAM

~

DANIELLE SCHALL - AD  
MICHELLE OLSAVSKY - IC

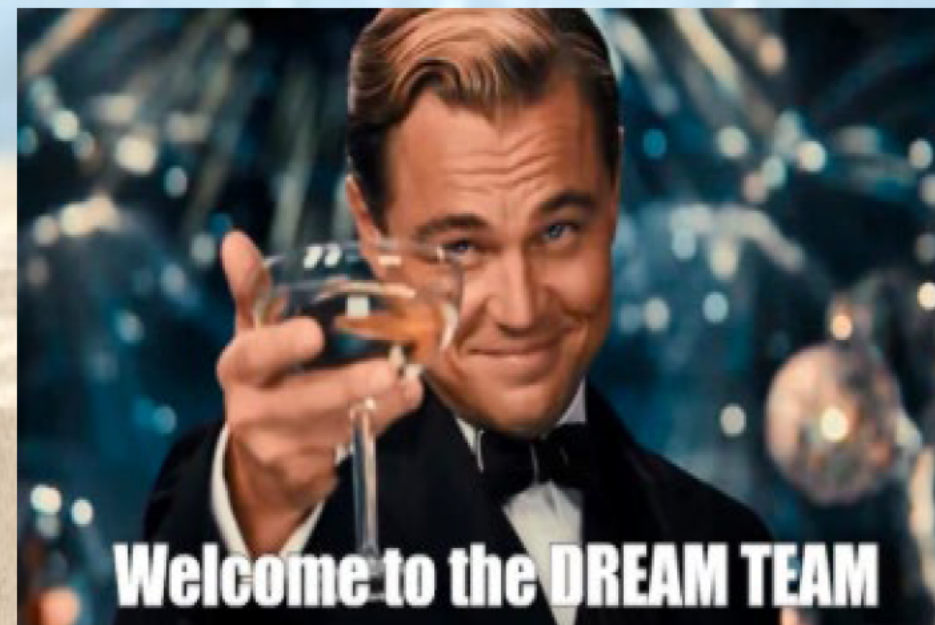

# **Agenda**

Special Education Credit Recovery 2022

June 8, 2022 @ 2:30 PM

Review Team (Replacement Courses & Regular Ed supports)

- Course Pacing
- Attendance
- Summer Scheduling
- Timeline
- Substitutes
- Expectations

[Join](#)[Close](#)

## SUMMARY

### 15

Attended

### 10:50 AM - 11:57 AM

Start and end time

### 1h 6m 43s

Meeting duration

### 32m 17s

Average attendance time

## PARTICIPANTS

Name	Duration	Join time	Leave time	Role
Lisa Savitz lsavitz@agora.org	37m 28s	10:50 AM	11:28 AM	Presenter
Shari Widlund swidlund@agora.org	37m 12s	10:50 AM	11:28 AM	Presenter
Jennifer Flatley jflatley@agora.org	36m 38s	10:51 AM	11:28 AM	Presenter
Carissa Emrick cemrick@agora.org	35m 5s	10:53 AM	11:28 AM	Presenter
Brett Stevens bstevens2@agora.org	33m 38s	10:54 AM	11:28 AM	Presenter
Erinn Slacktish eslacktish@agora.org	32m 1s	10:56 AM	11:28 AM	Presenter
Serena Costello scostello@agora.org	30m 30s	10:57 AM	11:28 AM	Presenter
Danielle Schall dschall@agora.org	30m 50s	10:57 AM	11:28 AM	Presenter

# TODAY'S OBJECTIVES

- Special Education Attendance Process
- Revising the IEP & Completing a SAIP



Timestamp	Email Address	Name	PPID	Supervisor	
8/11/2020 16:09:17	eslacktish@agora.org	First Name	Last Name	ANSWER KEY	
8/10/2020 16:17:54	bfroehlich@agora.org	Brittany	Froehlich	5897815	Lucia
8/11/2020 9:47:35	lolbryk@agora.org	Lacey	Olbryk	8725401	Lucia
8/11/2020 14:10:36	asweeney@agora.org	Allison	Sweeney	6797603	Natale
8/11/2020 14:39:46	cmack@agora.org	Cathryn	Mack	9457194	Johnson
8/11/2020 15:46:09	twalker@agora.org	Tara	Walker		Schall
8/11/2020 22:22:43	lsvonavec@agora.org	Lauren	Svonavec	6873915	Johnson
8/12/2020 7:39:19	bscears@agora.org	Breanne	Scears	2918713	Val Natale
8/12/2020 9:11:40	jshaffer3@agora.org	Janelle	Shaffer	1783096	Freyvogel
8/12/2020 9:15:59	kbeadle@agora.org	Karla	Beadle		Cukauskas
8/12/2020 12:09:49	jdepietro@agora.org	Jenn	DePietro	1051274	Witman
8/12/2020 12:35:02	jdeemer@agora.org	Judy	Deemer		Natale
8/12/2020 15:02:45	jbeeken@agora.org	Jennifer	Beeken	1431604	Freyvogel
8/12/2020 20:06:27	bcantwell@agora.org	Brittney	Cantwell	6989082	Johnson
8/13/2020 10:07:21	svietmeier@agora.org	Stacy	Vietmeier	5735753	Johnson
8/13/2020 10:45:26	aschmidt@agora.org	Ashley	Schmidt	6546756	Cukauskas
8/13/2020 11:28:25	cbarkley@agora.org	Cortney	Barkley	9674013	Lucia
8/13/2020 13:36:30	lstapf@agora.org	Laura	Stapf	5026504	Natale
8/13/2020 13:59:15	chartman@agora.org	Cathrine	Hartman	3606539	Cukauskas
8/13/2020 15:48:05	slelko@agora.org	Susan	Lelko	9089175	Natale
8/13/2020 15:48:19	nreimers@agora.org	Nancy	Reimers	6041706	Schall
8/14/2020 13:51:48	rperri@agora.org	Renee	Perri	1810325	Natale
8/14/2020 14:24:45	cganter@agora.org	Crysta	Ganter	1673067	Cukauskas
8/14/2020 17:38:21	lbrestensky@agora.org	Lisa	Brestensky	8491596	Freyvogel
8/14/2020 22:27:50	jreese@agora.org	Jessica	Reese	5207967	Lucia
8/17/2020 8:13:08	ckirchner@agora.org	Carly	Kirchner	6725723	Freyvogel
8/17/2020 10:45:27	cbryan@agora.org	Carol	Bryan	6408509	Cukauskas
8/17/2020 13:10:54	jfecik@agora.org	Justine	Fecik	1607938	Schall
8/17/2020 13:37:32	dfurka@agora.org	David	Furka	5839145	Johnson
8/17/2020 13:39:05	jhuffman@agora.org	Jena	Huffman	7165636	Natale
8/17/2020 20:06:34	klapsker@agora.org	Kristina	Lapsker		



<b>Timestamp</b>	<b>Email Address</b>	<b>Name</b>		<b>PPID</b>	<b>Supervisor</b>
8/18/2020 11:05:17	aarmstrong@agora.org	Amanda	Armstrong	1830841	Freyvogel
8/18/2020 11:05:19	mgaso@agora.org	Melissa	Gaso	1678431	Natale
8/18/2020 11:48:33	nkrol@agora.org	Nicole	Krol	8487304	Freyvogel
8/18/2020 12:19:35	kfitzgerald@agora.org	Kim	Fitzgerald	7953824	Lucia
8/18/2020 13:35:37	jdunlap@agora.org	Jill	Dunlap	3951391	Freyvogel
8/18/2020 13:39:38	lradico@agora.org	Lauren	Radico	5674767	Freyvogel
8/18/2020 13:57:21	dodonnell@agora.org	Dana	O'Donnell	5397505	Johnson
8/18/2020 15:21:25	oeckels@agora.org	Olivia	Eckels	1835849	Cukauskas
8/18/2020 15:38:49	slipiec@agora.org	Susan	Lipiec	7462653	Lucia
8/18/2020 15:51:27	jcapitano@agora.org	Jesse	Capitano	8981801	Freyvogel
8/18/2020 16:32:45	mstump@agora.org	Melissa	Stump	8359342	Natale
8/18/2020 17:23:11	adenham@agora.org	Angie	Denham	5837679	Witman
8/18/2020 19:19:32	kcostanzo@agora.org	Kristal	Costanzo	4721493	Lucia
8/19/2020 12:29:00	cpanchura@agora.org	Chelsey	Panchura	5735207	Freyvogel
8/19/2020 13:04:57	lspratt@agora.org	Leslie	Spratt	2579716	Johnson
8/19/2020 13:28:28	kwelsh@agora.org	Kristy	Welsh	3715812	Natale
8/19/2020 14:04:01	thunkele@agora.org	Terri	Hunkele	7871924	Schall
8/19/2020 14:17:41	jdietrich@agora.org	Jenna	Dietrich	4096064	Lucia
8/19/2020 18:33:36	astaley2@agora.org	Amber	Staley	2865256	Freyvogel
8/19/2020 20:04:12	mpelissier@agora.org	Michelle	Pelissier	1391528	Johnson
8/19/2020 20:59:44	hsilberman@agora.org	Heather	Silberman		Schall
8/19/2020 21:11:16	jmoyer2@agora.org	Jill	Moyer		Schall
8/20/2020 13:30:53	rcongdon@agora.org	Rebekah	Congdon	5045706	Schall
8/20/2020 21:31:40	jbarnhart@agora.org	Jessica	Barnhart	4590197	Lucia
8/21/2020 9:26:40	mlove@agora.org	Melissa	Love	1097861	Schall
8/21/2020 9:50:17	tdraeger@agora.org	Theresa	Draeger	1585189	Schall
8/21/2020 12:44:58	jzollman@agora.org	Jennifer	Zollman	8725829	Natale
8/21/2020 23:42:12	mgarczynski@agora.org	Molly	Garczynski	8048158	Johnson
8/22/2020 10:20:46	alarge@agora.org	Allison	Large	7934971	Freyvogel
8/22/2020 13:49:32	skennedy@agora.org	Sabrina	Kennedy	8258565	Natale

Timestamp	Email Address	Name		PPID	Supervisor
8/23/2020 10:02:27	lkerns@agora.org	Lauren	Kerns	6463102	Natale
8/23/2020 16:54:22	syounng@agora.org	Sasha	Young	6136347	Schall
8/23/2020 17:39:05	amalec@agora.org	Ashley	Malec	1652126	Lucia
8/23/2020 17:46:49	dpacolay@agora.org	Dana	Pacolay	5325374	Freyvogel
8/23/2020 18:00:49	jseverino@agora.org	Jill	Severino	1205208	Lucia
8/23/2020 20:09:34	abrisbane@agora.org	Amber	Brisbane	3612063	Witman
8/24/2020 4:47:10	hcobert@agora.org	Heather	Cobert	4102713	Freyvogel
8/24/2020 9:26:21	cemrick@agora.org	Carissa	Emrick	5403689	Schall
8/24/2020 10:02:30	jbuss@agora.org	Jennifer	Buss	5732496	Cukauskas
8/24/2020 10:23:14	lpagliei@agora.org	Lynn	Pagliei	3109573	Schall
8/24/2020 10:30:20	gmallon@agora.org	Regina	Mallon	1907396	Cukauskas
8/24/2020 10:31:07	afarster@agora.org	Ashley	Farster	2480142	Cukauskas
8/24/2020 11:20:45	tambuka@agora.org	Tracey	Ambuka	2941592	Freyvogel
8/24/2020 14:47:00	akimmage@agora.org	Amanda	Moyer	3056185	Schall
8/24/2020 15:18:03	gfiscus@agora.org	Grace	Fiscus	8105219	Cukauskas
8/24/2020 16:55:32	cbaker@agora.org	Chris	Baker	6760832	Lucia
8/24/2020 19:29:17	kpaolino@agora.org	Kim	Paolino	3172707	Johnson
8/24/2020 20:00:40	jlinderman@agora.org	Jessica	Linderman	9045025	Johnson
8/24/2020 20:06:37	cwiddop@agora.org	Christen	Widdop	6597585	Cukauskas
8/24/2020 20:12:17	bpontious@agora.org	Brianna	Pontious	9616535	Lucia
8/24/2020 21:35:20	bfink@agora.org	Brittany	Fink	9891649	Johnson
8/24/2020 23:34:43	jdoebereiner@agora.org	Julie	Doebereiner	7489562	Lucia
8/25/2020 7:09:21	lsavitz@agora.org	Lisa	Savitz	6402734	Schall
8/25/2020 7:51:17	lsavitz@agora.org	Lisa	Savitz	6402734	Schall
8/25/2020 8:16:48	gdonch@agora.org	Gina	Rodriguez	3791683	Cukauskas
8/25/2020 14:24:16	jcadioux@agora.org	Jenn	Cadioux	2746171	Freyvogel
8/25/2020 15:32:19	hdodge@agora.org	Heidi	Dodge	2569601	Johnson
8/26/2020 12:28:55	cramsey@agora.org	Cathryn	Ramsey	8190103	Lucia
8/26/2020 12:32:17	ehenretta@agora.org	Erikka	Henretta	1872897	Cukauskas
8/26/2020 12:45:28	mbasso@agora.org	Maura	Basso	6941361	Lucia

<b>Timestamp</b>	<b>Email Address</b>	<b>Name</b>		<b>PPID</b>	<b>Supervisor</b>
8/31/2020 13:21:53	mbotti@agora.org	Michelle	Botti	9294146	Lucia
9/1/2020 13:51:36	khoffman@agora.org	Kaelyn	Hoffman	5371396	Lucia
9/3/2020 10:23:57	kshannon@agora.org	Keri	Shannon	5341385	Natale
9/7/2020 13:21:15	bcooper@agora.org	Barb	Cooper		Schall
9/8/2020 11:11:54	mmccracken@agora.org	Melissa	McCracken	7467268	Freyvogel
9/15/2020 9:25:05	llamison@agora.org	Lauren Lamison		9614984	Natale
9/15/2020 9:46:24	scostello@agora.org	Serena Costello		6237909	Natale
9/15/2020 11:00:20	nhollenbach@agora.org	Nicolette Hollenbach		5776786	Natale
9/16/2020 15:45:42	araught@agora.org	Amy Raught		4603802	Freyvogel
9/16/2020 22:36:17	tkozak@agora.org	Tamara Kozak		2986176	Natale
9/29/2020 11:14:06	hgallagher@agora.org	Heather Gallagher		7959715	Natale
10/8/2020 16:17:43	akammermeier@agora.or	Amanda Kammermeier		2010834	Natale

# Meeting Agenda

## Updates and Reminders

- Who's Who
- Expectations (team / professionalism)
- Communication Protocols
- Tyler Documentation
- Grading Policies
- Catch-Up Days
- Common Planning Block
- PTO
- Differentiated Supervision
- Advisory Welcome Calls
- Odds and Ends
- Student Assembly Info
- Good of the Group



**Freyvogel Team Training Attendance 8/23/21**

Allison Large

Amanda Armstrong

Amber Staley

Brett Stevens

Carissa Emrick

Chelsey Panchura

Colien Byers

Colleen Freyvogel Bruss

Dana Pacolay

Erin Scrip

Janelle Shaffer

Jennifer Beeken

Jennifer Cadiuex

Kimberly Fiscus

Kristy Welsh

Lauren Radico

Lisa Brestensky

Melissa McCracken

Nicole Krol

Regina Kubica

Renee Perri

Shannon Hoffmaster

Tracey Ambuka

Whitney Bargerstock

# AGENDA



- ❑ Roster Setup
- ❑ Diagnostic Assessment Implementation
- ❑ Personalized Practice Implementation & SmartScore
  - ❑ Working on the Weekly Recommendations
  - ❑ Working on the Weekly Diagnostic
- ❑ Dig into Data
  - ❑ Where is it all? And what am I looking at?
- ❑ Daily/Whole Class Instruction & Interventions
  - ❑ Interventions
  - ❑ Manipulate lessons
  - ❑ Supplement curriculum
- ❑ Standards Prep Implementation
- ❑ Progress Reports



1193241\_MS. KIMBERLY FISCUS\_Agora TEACHER

KIMBERLY FISCUS (Moderator)  
Whitney Bargerstock (Participant)  
Freyvogel\_Janelle Shaffer (Participant)  
Schall\_Terri Hunkele (Participant)  
Freyvogel\_Amy Raught (Participant)  
Freyvogel\_Brett Stevens 1 (Participant)  
freyvogel\_jenn cadieux (Participant)  
Nagy\_Beth Ryan (Participant)  
Freyvogel\_Allison Large (Participant)  
Freyvogel\_Bruss\_ReneePerri (Participant)  
Schall\_Theresa Draeger (Participant)  
Schall\_Mandi Moyer (Participant)  
Schall\_Becky Congdon (Participant)  
Schall\_Jill Moyer (Participant)  
Freyvogel-Bruss\_Jess Capitano (Participant)  
Freyvogel\_Amber Staley (Participant)  
Nicole Krol (Participant)  
Schall\_Sasha Young (Participant)  
Erinn Slacktish (Participant)  
Nagy\_Judy Marsiliano (Participant)  
Nagy\_Jill Boisvert (Participant)  
Freyvogel\_Heather\_Cobert (Participant)  
Freyvogel\_Dana Pacolay (Participant)  
Freyvogel\_Bruss\_Jennifer Beeken (Participant)  
Freyvogel\_Chelsey Panchura (Participant)



## Agenda

- \*Team Referral
- \*Parent Request
- \*Already Identified Students
- \*Teacher Ratings and Input

## **QUESTIONS?**

DROP IN CHAT

Q & A TO FOLLOW



1225280\_MS. ERINN SLACKTISH\_AGORA TEACHER

AGORA ADMIN (Moderator)  
Kate Giordano (Moderator)  
Szczepkowski\_Debra McTague (Participant)  
Hornbake\_Robin Hartman (Participant)  
Hilson\_RebeccaKenzkowski (Participant)  
Kozar\_Noreen Davish (Participant)  
McCormick\_Barbara Karp (Participant)  
Montgomery\_Jessi Eberly (Participant)  
Hilson\_Bri Ryen (Participant)  
Kozar\_Casey Oakes (Participant)  
Nagy\_Beth Ryan (Participant)  
Kozar\_Luke Lubich (Participant)  
Allen\_Barbara Thayer (Participant)  
Montgomery\_Megan Kiebler (Participant)  
Kozar\_Heidi Lucier (Participant)  
Hilson\_Sarah Rau (Participant)  
Nagy\_Judy Marsiliano (Participant)  
Szczepkowski\_Chris Moser (Participant)  
Hawk\_Jennifer Connelly (Participant)  
Nagy\_Gil McGlynn (Participant)  
Allen\_Allison Read (Participant)  
Hawk\_Erin Nawn (Participant)  
Hilson\_Heather Stiles (Participant)  
Szczepkowski\_Renee Dachenhausen (Participant)  
Bianconi\_Linda Dupes (Participant)  
Montgomery\_Laurel Breyak (Participant)  
Montgomery\_Melissa Erdmann (Participant)  
Buffington\_Amy Barrett (Participant)  
Hornbake\_Katie Wright (Participant)  
Keth\_Laurie Daugherty (Participant)  
McCormick\_Alison Force (Participant)  
Kreider\_Amanda Mullen (Participant)  
Goldman\_Jeannine Rogers (Participant)  
Hawk\_Tammy Saad (Participant)  
Buffington\_Selina Shepard (Participant)  
Allen\_Aggie Patrick (Participant)  
McCormick\_Nicole Camaioni (Participant)  
Goldman\_Jenn Szerlag (Participant)  
McCormick\_Wes Marquis (Participant)  
Montgomery\_Lisa Salony (Participant)  
shebeck\_brigitt watts (Participant)  
Szczepkowski\_Nancy Janelli (Participant)  
Shebeck\_Sharon Lynn (Participant)  
Szczepkowski\_Cassie Thomas (Participant)  
Buffington\_Suzanne Postler (Participant)  
Keth\_Ryan Baird (Participant)  
Allen\_Tovah MacLacklin (Participant)  
Hilson\_Ericka Nicol (Participant)  
Montgomery\_Jennifer Thompson (Participant)  
Kozar\_Erin Howe (Participant)  
Szczepkowski\_Carrie Yapple (Participant)

Nagy\_Steve Gussow (Participant)  
Hilson\_Lisa Karosas (Participant)  
Allen\_Jordan Alderson (Participant)  
Hornbake\_Denise Curry (Participant)  
Hawk\_Felicia Rizzo (Participant)  
Szczepkowski\_Angie Green (Participant)  
Allen\_Samantha Miller (Participant)  
Montgomery\_Christy Nickerson-Little (Participant)  
Bianconi\_Dorry Altman (Participant)  
McCormick\_Jaclyn Scherrbaum (Participant)  
Goldman\_Tiffany Joyner (Participant)  
McCormick\_Ocie Hill (Participant)  
Kozar\_Lauren Schlager (Participant)  
Buffington\_Catherine Brand (Participant)  
Kozar\_Pam Sieger (Participant)  
Hawk\_Olivia Schwartz (Participant)  
Kreider\_Jen Barrios (Participant)  
Szczepkowski\_Chad Mullen (Participant)  
Szczepkowski\_Tara Brandt (Participant)  
Keth\_Lillian Marquez (Participant)  
Bianconi\_MelanieHathaway (Participant)  
Montgomery\_Beth Maines (Participant)  
Nagy\_Kimberly Worrell (Participant)  
Keth\_Stella Petraglia (Participant)  
Montgomery\_Jean Brennan (Participant)  
Butler\_Jeff Miller (Participant)  
Szczepkowski\_Michael Chapman (Participant)  
Szczepkowski\_Shelley Rex (Participant)  
Goldman\_Michael Reaves :) (Participant)  
Hawk\_Tawny Binder (Participant)  
ward (Participant)  
Allen\_Darian Kiger (Participant)  
Bianconi\_Mike Smyntek (Participant)  
Szczepkowski\_Gaila Swindell (Participant)  
Buffington\_Brandon Bird (Participant)  
Miller\_Annie Mueller (Participant)  
Montgomery\_Jen Johnston (Participant)  
Detwiler\_William Kunkel (Participant)  
Montgomery\_Connie Barber (Participant)  
Detwiler\_Jessica Porreca (Participant)  
Bianconi\_Dean Griffith (Participant)  
Kreider\_Susan Detwiler (Participant)  
Szczepkowski\_Ginger Shaffer (Participant)  
Goldman\_Melissa Rodway (Participant)  
McCormick\_Susan Clark (Participant)  
Keth\_David Steinfurth (Participant)  
Nagy\_Marcy Purdy (Participant)  
Buffington\_Robert Pratt (Participant)  
Detwiler\_Carla Krochak (Participant)  
Buffington\_Marisa Walter (Participant)  
Montgomery\_Jill Schar (Participant)  
Montgomery\_Jamie Shaffer (Participant)  
Hawk\_Camille Arcuri (Participant)  
Kozar\_Laurie Pastin (Participant)

Buffington\_Barb Harvey (Participant)  
Montgomery\_Adrienne McCreary (Participant)  
Kozar\_Ali Shaltes (Participant)  
Keth\_Janet Panza (Participant)  
Hawk\_Jenn Royer (Participant)  
Montgomery\_Lauren Witmer (Participant)  
Bianconi\_Gabrielle Ferrara (Participant)  
Shebeck\_Elley Jimenez (Participant)  
Montgomery\_Shauna Rosenberger (Participant)  
Bianconi\_Dayna Houseknecht (Participant)  
Detwiler\_Chakola Hall (Participant)  
Montgomery\_Jill Mahon (Participant)  
Miller\_Frank Nagy (Participant)  
Montgomery\_Carol Bryan (Participant)  
Montgomery\_Melissa Creaven (Participant)  
Bianconi\_Jacque Monterroso (Participant)  
Goldman\_Jessica Martinez (Participant)  
Keth\_Rich Lipski (Participant)  
Hawk\_Melissa Mikkelsen (Participant)  
Montgomery\_Kristen Lanzilotta (Participant)  
Miller\_Regan Shebeck (Participant)  
Montgomery\_Kim Strong (Participant)  
Hawk\_Jaymee Stadler (Participant)  
Montgomery\_Melissa McCreedy (Participant)  
Allen\_Kelly Pease (Participant)  
Montgomery\_Shannon Angelo (Participant)  
Bianconi\_Anne Dillon (Participant)  
Hilson\_Joseph B Smith (Participant)  
Keth\_Stephanie Lyman (Participant)  
Shebeck\_Brynne Allcorn (Participant)  
Buffington\_Tammy Barger (Participant)  
Nagy\_Daniel Berkey (Participant)  
Steve Nugent (Participant)  
Bianconi\_Roberta Love (Participant)  
Shebeck\_Danielle Horton 1 (Participant)  
Detwiler\_Heather Ronco (Participant)  
Hilson\_Cindy Shonberg (Participant)  
Montgomery\_Krista Kowalok (Participant)  
Shebeck\_Jay Vasil (Participant)  
Buffington\_Scott Radio (Participant)  
Nagy\_Rebecca Adams (Participant)  
Miller\_Heather McCormick (Participant)  
Allen\_Mary Walsh (Participant)  
Palme\_Suzanne Klein (Participant)  
Allen\_Rosalyn Finlayson (Participant)  
Keth-MichelleGeorge (Participant)  
Miller\_Erin Hilson (Participant)  
Szczepkowski\_Sara Stephenson (Participant)  
Montgomery\_Jill Buck (Participant)  
Hilson\_Diane Kunitsky (Participant)  
Hilson\_Taryn Morgan (Participant)  
Dani Pricer (Moderator)  
Palme\_Roxanne Zeisloft (Participant)  
Nagy\_JeremyCarver (Participant)

Shebeck\_Tom Shields (Participant)  
Hornbake\_Mike Floyd (Participant)  
Montgomery\_Ashley Alcorn (Participant)  
Montgomery\_Kim Gallis (Participant)  
Buffington\_Mark Laser (Participant)  
Montgomery\_Rachel Sams (Participant)  
Detwiler\_Tyler Bui (Participant)  
Detwiler\_Chris Wrigley (Participant)  
Goldman\_Stephanie Whitted (Participant)  
Nagy\_Paul Folmar (Participant)  
Kozar\_Michelle Tilsner (Participant)  
Montgomery\_Jessica Boyer (Participant)  
Goldman\_Ahrin Gibbons (Participant)  
Detwiler\_Melissa Evangelista (Participant)  
Shebeck\_Jennifer Dumas (Participant)  
Shebeck\_Marc Kramer (Participant)  
Bianconi\_Valerie McCarthy (Participant)  
Goldman\_Mara Sears (Participant)  
Keth\_Pam Holtzman (Participant)  
Quisito\_Mike Mirth (Participant)  
Detwiler\_Jessica Porreca 1 (Participant)  
Kozar\_John Thomas (Participant)  
Hawk\_Shannon Ciarlone 1 (Participant)  
Kozar\_Kim Kreseski (Participant)  
Buffington\_Ashley Smith (Participant)  
Kozar\_Colleen Richardson (Participant)  
Szepkowski\_Judy Willison (Participant)  
Keth\_Molly Pratt (Participant)  
Kreider\_Pam Keth (Participant)  
McCormick\_Christopher Weisz (Participant)  
Lynn Wilson (Participant)  
Montgomery\_Natalie Steinberg (Participant)  
Hilson\_Marianne Keck (Participant)  
Hilson\_Emily Nugent (Participant)  
Hilson\_Christina Abul-Ela (Participant)  
Shebeck\_Jason Donley (Participant)  
Kozar\_Liz McEwen (Participant)  
Detwiler\_Monique Ketter (Participant)  
Buffington\_Amy Cadwallader (Participant)  
Allen\_John Riggs (Participant)  
Shebeck\_Trisa Lesczynski (Participant)  
Montgomery\_Amanda Tomik (Participant)  
Kozar\_Tracy Harris (Participant)  
Hawk\_Laura Logan (Participant)  
Montgomery\_Tammy McCauley (Participant)  
Keth\_Kristen Lake (Participant)  
Nagy\_Jill Boisvert (Participant)  
Kreider\_Kristin Thatcher (Participant)  
McCormick\_Christine Barney (Participant)  
McCormick\_Jon Pytko (Participant)  
Allen\_Shelly McGlothlin (Participant)  
Detwiler\_Cathy Stabilito (Participant)  
Goldman\_Taché Burnett (Participant)  
Allen\_Amber Tkach (Participant)

Nagy\_Cathy Boyer (Participant)  
Allen\_Janelle McKeown (Participant)  
Montgomery\_Casey Marshall (Participant)  
Kozar\_Beth Largent (Participant)  
McCormick\_Katie DiStefano (Participant)  
Shebeck\_Sarah Weikert (Participant)  
Hawk\_Ashley Wise (Participant)  
Hornbake\_Jim Montgomery (Participant)  
Keth\_Kimberly Watson (Participant)  
Hawk\_Grace Fiscus (Participant)  
Hilson\_Kate McAndrew (Participant)  
Szepkowski\_Kim Gruver (Participant)  
Hilson\_Julie McCrea (Participant)  
Hawk\_Chelsea Noss (Participant)  
Kozar\_Heather Bianconi (Participant)  
Keth\_Cindy Imbarlina (Participant)  
Detwiler\_Jessica Porreca 2 (Participant)  
Montgomery\_Katey Curry-Puskar (Participant)  
Goldman\_Kimyatta Woods (Participant)  
Goldman\_Jaime Sosonkin (Participant)  
Detwiler\_Katie Renner (Participant)  
Kreider\_Erin Owen (Participant)  
McCormick\_Jesse Nicholas (Participant)  
Kreider\_Eileen Nelson (Participant)  
Hawk\_Michelle Staab (Participant)  
Szepkowski\_Sandy Cashman (Participant)  
McCormick\_Jessica Whitmoyer (Participant)  
Bianconi\_Kelly Snyder (Participant)  
Bianconi\_Jill Phillips (Participant)  
Nagy\_Susan Tybl (Participant)  
Butler\_Tim Kreider (Participant)  
Kreider-Laura Goldman (Participant)  
Allen\_Meghan Stalebrink (Participant)  
Morgan Witman (Participant)  
Allen\_Jaime Lombardo (Participant)  
Bianconi\_Emily Sattler (Participant)  
Miller\_Morgan Galonski (Participant)  
Nagy\_Maureen Donnelly (Participant)  
Buffington\_Arlene Sheffo (Participant)  
Montgomery\_Janet Whippo (Participant)  
Hawk\_Michelle Verbecken (Participant)  
Nagy\_Michael\_McNulty (Participant)  
Shebeck\_Melissa Jusko (Participant)  
Quisito\_Amy Shea (Participant)  
Goldman\_Colleen Egan (Participant)  
Hornbake\_Kristie Hawk (Participant)  
Butler\_Jansen Hornbake (Participant)  
Buffington\_Michelle Klara (Participant)  
Hilson\_Melanie Walters (Participant)  
Hawk\_Lisa Hill (Participant)  
Hawk\_Elyse Alcott (Participant)  
Hawk\_Ashley Huff (Participant)  
Montgomery\_Ken Sarber (Participant)  
Quisito\_Erica Lee (Participant)

Buono\_James Lisk (Participant)  
Hilson\_Caleb Cragle (Participant)  
Shebeck\_LorySoda (Participant)  
Keth\_Misty Wilson (Participant)  
Nagy\_Lauren Goughnour (Participant)  
Shebeck\_Kate Brown (Participant)  
Butler\_Bridget Kozar (Participant)  
Shebeck\_Jennifer Martin (Participant)  
Hornbake\_Candace Kreutzer (Participant)  
Shebeck\_Erin Jackson (Participant)  
Miller\_Gina Evangelista (Participant)  
Allen\_Dena Petruzzelli (Participant)  
Detwiler\_Gwen Fredette (Participant)  
Buffington\_Karen Hamburger (Participant)  
Hawk\_Deborah LaVacca (Participant)  
Goldman\_Lauren Napoli (Participant)  
Kozar\_Bridget Kozar (Participant)  
Shebeck\_Megan Sinan (Participant)  
McCormick\_JP Tumas (Participant)  
Montgomery\_Kelli Moreno (Participant)  
Goldman\_Michele Pelipesky 1 (Participant)  
Shebeck\_Nicole Bowie (Participant)  
Shebeck\_Kevin McCracken (Participant)  
Erinn Slacktish (Participant)  
Montgomery\_Autumn Whitebread (Participant)  
Hilson\_Matthew Bruenn (Participant)  
Szczepkowski\_Deb Garrison (Participant)  
Shebeck\_Pam Heard 1 (Participant)  
Keth\_Carissa Ondesko Bost (Participant)  
Hilson\_Bob Galonski (Participant)  
Allen\_Sharon Kelso (Participant)  
Buffington\_Erin Tainter (Participant)  
Montgomery\_Ellen Hopkins 1 (Participant)  
McCormick\_Anita Deloe (Participant)  
Nagy\_Patty Smith (Participant)  
Goldman\_Mary Johnson (Participant)  
Nagy\_Daniel McMullen (Participant)  
Shebeck\_Rhonda Williams (Participant)  
Detwiler\_Jeremy Smith (Participant)  
Shebeck-Keith Platt (Participant)  
Shebeck\_Victoria E. Brownlie (Participant)  
Allen\_Danielle Kerner (Participant)  
Goldman\_Ashley Von Grossen (Participant)  
Shebeck\_Diane Broniszewski (Participant)  
Hawk\_Jalina Robosky (Participant)  
Allen\_Starr Whitten (Participant)  
Shebeck\_Jamie McCarthy (Participant)  
Hawk\_Grace CuvIELLO (Participant)  
McCormick\_David Clagett (Participant)  
Shebeck\_Ryan Webb (Participant)  
Allen\_Erica Macuga (Participant)  
Bianconi\_Leslie Laudenslager (Participant)  
Miller\_Holly Allen (Participant)  
Montgomery\_Caitlin Johnson (Participant)

Keth\_Andrea Baker (Participant)  
Hilson\_Cara Schweizer (Participant)  
Shebeck\_Meghan\_Lynn (Participant)  
Buffington\_Thy Schmick (Participant)  
Allen\_Ashly Staley (Participant)  
Bianconi\_Zoleanne Ruffner (Participant)  
Kreider\_Gina Szczepkowski (Participant)  
McCormick\_Jennine Thomas (Participant)  
Shebeck\_Sally Devinney (Participant)  
Hawk\_Beth Shoop (Participant)  
Quisito\_Kelly Noss (Participant)  
Detwiler\_Michele Trobman (Participant)  
Hilson\_Heather Coyne (Participant)  
Bianconi\_Kelly McCullough (Participant)  
Hilson\_MelissaHL (Participant)  
Buffington\_Andrew White (Participant)  
Nagy\_Sharon Berry (Participant)  
Hilson\_Shila Cramer (Participant)  
Kozar\_Jenna Gruber (Participant)  
McCormick\_Stephen Shuttleworth (Participant)  
Bianconi\_Corey McNulty (Participant)  
McCormick\_Sarah Menzler (Participant)  
Montgomery\_Karen Girard (Participant)  
Nagy\_Joanne Mulvey (Participant)  
Keth\_Kelly McQuaide #2 (Participant)  
Hawk\_Angela Majzlik (Participant)  
McCormick\_Angela Hetrick (Participant)  
Nagy\_Lori Andrews (Participant)  
Kreider\_Amy Shehan (Participant)



# NOTICE OF RECOMMENDED EDUCATION PLACEMENT

Elementary Mini PD Series- 3-10-22



# WHAT IS YOUR COMFORT LEVEL WITH NOREPS



## NOREP/PWN: Purpose

- Provides vehicle for LEA to ensure parent participation in special education process
- Summarizes for parents the recommendations of the LEA for the child's educational program and other actions taken by the LEA
- Outlines the recommended educational placement for the student and other options that were considered by the IEP team

## NOREP/PWN: Informed Consent

---



- LEA must ensure parent understands action/recommendation
- IDEA requires NOREP/PWN is
  - Written in language understandable to general public and
  - Provided in native language of parent or other mode of communication used by parent
    - Unless clearly not feasible to do so

34 CFR §300.503(c)

---

## NOREP/PWN: Contents of the PA Form

---



1. Type of action taken
2. Description of action proposed or refused by LEA
3. Explanation of why LEA proposed/refused to take the action
4. Description of other options IEP team considered and reasons why those options rejected
5. Description of each evaluation procedure, assessment, record or report LEA used in deciding to propose/refuse the action
6. Description of other factors relevant to LEA's proposal/refusal
7. The recommended educational placement for the child and statement that the parents of a child with a disability have protections under the law and how to obtain a copy of the Procedural Safeguards Notice
8. Parent Consent options
9. Sources for parents to contact for help in understanding the provisions of this part

**NOREP/PWVN:  
When  
Required**

**Required for these Types of Action**

- Proposal of initial provision of special education/related services
- Refusal to initiate evaluation
- Proposal/Refusal to change identification, evaluation, placement of child or provision of FAPE
- Disciplinary change of placement
- District-initiated due process hearing/expedited due process hearing
- Graduation from high school
- Exiting high school due to exceeding age eligibility for a FAPE
- Exiting special education
- Extended School Year (ESY) services
- Response to request for independent educational evaluation (IEE) at public expense

# NOREP/PWN: **When is Parental Consent Required?**

---



## • **Proposal of initial provision of special education/ related services**



- Refusal to initiate evaluation
- Proposal/Refusal to change identification, evaluation, placement of child or provision of FAPE
- Disciplinary change of placement
- District-initiated due process hearing/expedited due process hearing
- Graduation from high school
- Exiting high school due to exceeding age eligibility for a FAPE
- Exiting special education
- Extended School Year (ESY) services
- Response to request for independent educational evaluation (IEE) at public expense



## The WHO of the NOREP/PWN

- Purpose 1: The **LEA** completes the NOREP/PWN to notify the **parent(s)** of the school's action regarding the "child's"/student's educational program.
- Purpose 2: For the LEA Use Only Box: Record the business date this form was received by the LEA. This will act as documentation that the parent responded to the NOREP/PWN.

- Purpose 1 is what we provide to parents after we hold the IEP mtg.
- Purpose 2-Our office staff complete this. This helps keep us compliant with the 10 day timelines.



The WHY of the  
NOREP/PWN  
(global reasons)

- To remain in compliance with federal and state regulations.
  - Important! Procedural Safeguards Notice
    1. Initial provision of FAPE
    2. Change of placement due to disciplinary reasons

The agreement between LEA and parent in regards to education and programming for students. It is also used to remain in compliance with federal and state regulations.





The WHEN of the  
NOREP/PWN  
(Type of Action  
Taken by LEA)

- Proposes initial provision of special education and related services (For this action, the school may not proceed without your written consent in Section 8 of this document.)
- Refusal to initiate an evaluation (Must issue Procedural Safeguards Notice)
- Proposes to change the identification, evaluation or educational placement of the child or the provision of a free appropriate public education (FAPE)
- Refusal to change the identification, evaluation or educational placement of the child or the provision of a free appropriate public education (FAPE)
- Change of placement for disciplinary reasons (Must issue Procedural Safeguards Notice)



The WHEN of the  
NOREP/PWN –  
continued  
(Type of Action  
Taken LEA)

- Due process hearing, or an expedited due process hearing, initiated by school/district
- Graduation from high school
- Exiting special education
- Exiting high school due to exceeding the age eligibility for a free appropriate public education (FAPE)
- Refusal to change the identification, evaluation or a free appropriate public education (FAPE)
- Extended School Year (ESY) services
- Response to request for an independent educational evaluation (IEE) at public expense
- Other

\*The first action, requires parental consent, may not proceed without it.

\*If you have discussed ESY in the meeting, you should also check ESY box and note it in the IEP. (That way you don't have to issue a separate ESY NOREP, in most situations.

## The HOW of the NOREP/PWN

### LEA completes each section as follows:

#### 1. The type of action taken

##### 1. Type of action taken:

- Proposes initial provision of special education and related services (For this action, the school may not proceed without your written ~~consent in Section 8 of this document.~~)
- Refusal to initiate an evaluation (Must issue Procedural Safeguards Notice)
- Proposes to change the identification, evaluation or educational placement of the child or the provision of a free appropriate public education (FAPE)
- Refusal to change the identification, evaluation or educational placement of the child or the provision of a free appropriate public education (FAPE)
- Change of placement for disciplinary reasons (Must issue Procedural Safeguards Notice)
- Due process hearing, or an expedited due process hearing, ~~initiated by school district~~
- Graduation from high school
- Exiting special education
- Exiting high school due to exceeding the age eligibility for a free appropriate public education (FAPE)
- Refusal to change the identification, evaluation or a free appropriate public education (FAPE)
- Extended School Year (ESY) services
- Response to request for an independent educational evaluation (IEE) at public expense
- Other



## The HOW of the NOREP/PWN

### LEA completes each section as follows:

2. The description of the action proposed or refused by the LEA/school district
3. An explanation of why the LEA/school district proposed or refused to take the action
4. A description of other options that the IEP team considered and the reasons why those options were rejected.

Options Considered	Reason for Rejection

2. Indicate what you are proposing (or refusing)

3. This is provides the reasons why the actions were proposed: Eval data says they don't meet eligibility any longer. Has met exit criteria; an evaluation and considers the data valid

4. Reasons why the options weren't found to in need of specific supports. Must begin with the general ed option first.



# Options Considered

4. A description of other options that the IEP team considered and the reasons why those options were rejected. If the action proposed or refused is in regard to educational placement, options considered must begin with the regular educational environment with supplementary aids and services (information about supplementary aids and services is available on the PaTTAN website at [www.pattan.net](http://www.pattan.net)):

Click to add text

Options Considered	Reason for Rejection

**Provides the team options to document the options considered and explain that a specific option was not proposed. Should include options on the continuum**



The HOW of the  
NOREP/PWN  
(continued)

LEA completes each section as follows:

5. A description of each evaluation procedure(s), assessment(s), record(s) or report(s) used as a basis for the proposed action or action refused
6. A description of other factors that were relevant to the school's/district's proposal or refusal
7. The educational placement recommended for your child is: (State the type of supports, e.g., Itinerant Learning Support, Supplemental Autistic Support, Full-Time Emotional Support)

5. Your records, procedures, etc.  
Examples: MTSS, PM data, Oral Reading Fluency Data, parent observations, data from classroom observations, PSSA data, etc

6. Other Factors: We usually put None. (student has a medical condition that requires an extended leave from school.

7. Informs amount and type of supports that are being recommended.

- Itinerant/Supplemental/Full Time- only choose one.
- Type of support, Learning, Emotional, Speech and Language, Autistic Support, etc. You can choose more than one here. Make sure what the student is receiving is noted here.



Parental Consent  
(refers back to  
the global  
"WHY")

- Parents are to select the appropriate option indicating their approval or disapproval of the proposed action.
  - ✓ I request a meeting to discuss this recommendation with school personnel
  - ✓ I approve this action/recommendation.
  - ✓ I do not approve this action/recommendation.

- Parent selects one of the options and signs. You may want to review this with parents for newly ID students, as this is a new process for the parent. Helping them understand this section can help clear up any confusion that they may have when they look at this document in DocuSign.



Parental Consent  
(refers back to  
the global  
"WHY")  
(continued)

1 request a meeting to discuss this recommendation with school personnel

I approve this action/recommendation.

I do not approve this action/recommendation.\* My reason for disapproval is:



I request: (Contact the Office for Dispute Resolution at 800-222-3353 for additional information)

2  Mediation

3  Due process hearing



# Parental Consent on NOREP/PWN

## 8. PARENTAL CONSENT

• Directions for Parent/Guardian/Surrogate: Please check one of the options, sign this form, and return it within 10 calendar days. In circumstances when this form is NOT completed and parental consent is NOT required, the school will proceed as proposed after 10 calendar days.

- I request an informal meeting with school personnel to discuss this recommendation.
- I approve this action/recommendation.
- I do not approve this action/recommendation.\* My reason for disapproval is:

I request (Contact the Office for Dispute Resolution at 800-222-3353 for information on Mediation and Due Process Hearing):

- Mediation
- Due Process Hearing

\* Except for placement in an interim alternative educational setting due to drugs, weapons, or serious bodily injury (§300.530(g), §300.530(i), and §300.531), if you do not approve the action/recommendation, your child will remain in the current program/placement only if you request a due process hearing or mediation through the Office for Dispute Resolution. If you do not request Due Process or Mediation through the Office for Dispute Resolution, the LEA will implement the action/recommendation.

## NOREP/PWN: **When is the PSN Also Required?**

- Proposal of initial provision of special education/related services
- **Refusal to initiate evaluation**
- Proposal/Refusal to change identification, evaluation, placement of child or provision of FAPE
- **Disciplinary change of placement**
- District-initiated due process hearing/expedited due process hearing
- Graduation from high school
- Exiting high school due to exceeding age eligibility for a FAPE
- Exiting special education
- Extended School Year (ESY) services
- Response to request for independent educational evaluation (IEE) at public expense

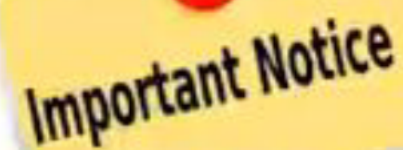

**Important Notice**

**When parent requests mediation or a due process hearing, LEA must provide PSN, which contains Due Process Complaint Notice.**

# NOREP/PWN: Timelines for Consent

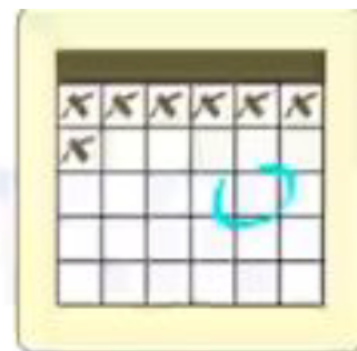

## Notice must be given reasonable time before LEA proposes/refuses action

- Reasonable determined to be 10 calendar days in PA

## Consent options for parents

- Request meeting with LEA personnel to discuss action/recommendation
- Approval of action/recommendation
- Request for mediation/due process hearing

## Parental response

- Parents have 10 calendar days to approve/disapprove of LEA recommendations after receipt of NOREP/PWN

## NOREP/PWN: Timelines for Consent (cont'd)

---

If parent does not approve the action/recommendation, child remains in current program/placement only if parent requests due process hearing or mediation through the Office for Dispute Resolution

If NOREP/PWN is NOT completed and parent consent is NOT required, the school can proceed as proposed after 10 calendar days

- LEA must wait 10 calendar days for parents to respond to NOREP/PWN
- Impacts on implementation date of the IEP

# EXAMPLE: INITIAL PROVISION

## 1. Type of action taken:

- Proposes initial provision of special education and related services (For
- Refusal to initiate an evaluation (Must issue *Procedural Safeguards N*
- Proposes to change the identification, evaluation or educational place
- Refusal to change the identification, evaluation or educational placem
- Change of placement for disciplinary reasons (Must issue Procedural
- Due process hearing, or an expedited due process hearing, initiated b
- Graduation from high school
- Exiting special education
- Exiting high school due to exceeding the age eligibility for a free appr
- Extended School Year (ESY) services
- Response to request for an independent educational evaluation (IEE)
- Other:



2. A description of the action proposed or refused by the LEA:

Agora proposes to implement [REDACTED] IEP developed as a result of an Evaluation Report (ER) dated [REDACTED], Speech Reevaluation Report (RR) dated [REDACTED], and IEP meetings held on [REDACTED] and [REDACTED]. A copy of the IEP is attached. Through the IEP, Agora proposes an itinerant autistic and learning support program with occupational and speech/language therapies.

3. An explanation of why the LEA proposed or refused to take the action:

Agora proposes this action in response to review of [REDACTED] ER, RR, and the IEP team meeting held on [REDACTED]

4. A description of other options that the IEP team considered and the reasons why those options were rejected. If the action proposed or refused is in regard to educational placement, options considered must begin with the regular educational environment with supplementary aids and services (information about supplementary aids and services is available on the PaTTAN website at [www.pattan.net](http://www.pattan.net))

	Options Considered	Reason for Rejection
	[REDACTED] would return to the general education environment without special education programming or services.	[REDACTED] is eligible for and in need of Special Education services to make appropriate progress.
	[REDACTED] would receive Supplemental Learning and Autistic Support with related services.	Reports and team discussion indicate that an itinerant program with related services is [REDACTED] Least Restrictive Environment at this time.

---

5. A description of each evaluation procedure, assessment, record or report used as a basis for the proposed action or action refused:

The following items were used as a basis for this proposed action: ER, RR, IEP team observations, data, and discussions.

7. The educational placement recommended for your child is

---

Itinerant Autistic and Learning Support

Speech/Language Therapy

Occupational Therapy



---

This is to notify you of the Local Education Agency's (LEA's) action regarding your child's educational program.

1. Type of action taken:

- Proposes initial provision of special education and related services (For this action, the school may not proceed without your written consent in Section 8 of this document)
- Refusal to initiate an evaluation (Must issue *Procedural Safeguards Notice*)
- Proposes to change the identification, evaluation or educational placement of the child or the provision of a free appropriate public education (FAPE)
- Refusal to change the identification, evaluation or educational placement of the child or the provision of a free appropriate public education (FAPE)
- Change of placement for disciplinary reasons (Must issue *Procedural Safeguards Notice*)
- Due process hearing, or an expedited due process hearing, initiated by LEA
- Graduation from high school
- Exiting special education
- Exiting high school due to exceeding the age eligibility for a free appropriate public education (FAPE)
- Extended School Year (ESY) services
- Response to request for an independent educational evaluation (IEE) at public expense
- Other:



2. A description of the action proposed or refused by the LEA:

Agora proposes to implement [REDACTED] IEP dated [REDACTED] with revisions on 2/12/21, 2/26/21, and 3/25/21. A copy of the IEP is attached. Through this IEP, Agora proposes a Supplemental Autistic and Speech/Language Support program with Occupational Therapy, Counseling services, Board Certified Behavior Analyst (BCBA) Services, Personal Care Assistant (PCA) Services, 1:1 Certified Special Education Teacher services, Psychology Services for team consultation, and Extended School Year services for the summer of [REDACTED].

3. An explanation of why the LEA proposed or refused to take the action:

Agora proposes this action in response to IEP meetings, an informal meeting, and IEP revisions noted in this IEP.

4. A description of other options that the IEP team considered and the reasons why those options were rejected. If the action proposed or refused is in regard to educational placement, options considered must begin with the regular educational environment with supplementary aids and services (information about supplementary aids and services is available on the PaTTAN website at [www.pattan.net](http://www.pattan.net))

	Options Considered	Reason for Rejection
	[REDACTED] would return to the general education environment without special education programming and services.	[REDACTED] is eligible for and in need of special education services to make appropriate progress.
	[REDACTED] would receive Itinerant Autistic and Speech/Language Support.	Data, documentation, and team discussion indicate that [REDACTED] requires a supplemental special education placement to make appropriate progress.
	[REDACTED] would receive Full-Time Autistic and Speech/Language Support.	Data, documentation, and team discussion indicate that [REDACTED] requires a supplemental special education placement to make appropriate progress.
	[REDACTED] would not receive extended school year services in [REDACTED].	Data indicates that [REDACTED] qualifies for ESY for [REDACTED].

5. A description of each evaluation procedure, assessment, record or report used as a basis for the proposed action or action refused:

The following items were used as a basis for this action: Evaluation Report dated [REDACTED], [REDACTED], Curriculum Progress and Curriculum Based Assessments, progress monitoring data, present levels of functional and academic performance, IEP team meetings on [REDACTED], [REDACTED], and [REDACTED], IEP revisions, parent input, teacher input and data collection, and related service provider input and data collection.

6. A description of other factors that were relevant to the LEA's proposal or refusal:

There are no other factors of note.

7. The educational placement recommended for your child is (State the amount and type of special education supports, e.g., Itinerant Learning Support, Supplemental Autistic Support, Full-Time Emotional Support):

Supplemental Autistic and Speech/Language Support  
Occupational Therapy  
Counseling Services  
Board Certified Behavior Analyst (BCBA) Services  
Personal Care Assistant (PCA) Services  
1:1 Certified Special Education Teacher  
Psychology Services for team consultation  
Extended School Year for 2021



**QUESTIONS?**



1. Summary						
Attended participants	7					
Start time	3/10/22, 11:56:23 AM					
End time	3/10/22, 12:33:09 PM					
Meeting duration	36m 46s					
Average attendance time	22m 47s					
2. Participants						
Name	First join	Last leave	In-meeting duration	Email	Participant ID (UPN)	Role
Jennifer Buss	3/10/22, 11:56:32 AM	3/10/22, 12:21:52 PM	25m 20s	jbuss@agora.org	jbuss@agora.org	Presenter
Michelle Cukauskas	3/10/22, 11:56:54 AM	3/10/22, 12:33:09 PM	36m 14s	mcukauskas@agora.org	mcukauskas@agora.org	Organizer
Amanda Gruszewski	3/10/22, 11:59:18 AM	3/10/22, 12:21:52 PM	22m 33s	agruszewski@agora.org	agruszewski@agora.org	Presenter
Ashley Farster	3/10/22, 12:00:26 PM	3/10/22, 12:21:50 PM	21m 23s	afarster@agora.org	afarster@agora.org	Presenter
Casey Chaffin	3/10/22, 12:01:15 PM	3/10/22, 12:33:07 PM	31m 51s	cchaffin@agora.org	cchaffin@agora.org	Presenter
Carmen Riggle	3/10/22, 12:08:14 PM	3/10/22, 12:21:07 PM	12m 52s	criggle@agora.org	criggle@agora.org	Presenter
Janet Ulewicz	3/10/22, 12:12:35 PM	3/10/22, 12:21:53 PM	9m 18s	julewicz@agora.org	julewicz@agora.org	Presenter
3. In-Meeting activities						
Name	Join time	Leave time	Duration	Email	Role	
Jennifer Buss	3/10/22, 11:56:32 AM	3/10/22, 12:21:52 PM	25m 20s	jbuss@agora.org	Presenter	
Michelle Cukauskas	3/10/22, 11:56:54 AM	3/10/22, 12:33:09 PM	36m 14s	mcukauskas@agora.org	Organizer	
Amanda Gruszewski	3/10/22, 11:59:18 AM	3/10/22, 12:21:52 PM	22m 33s	agruszewski@agora.org	Presenter	
Ashley Farster	3/10/22, 12:00:26 PM	3/10/22, 12:21:50 PM	21m 23s	afarster@agora.org	Presenter	
Casey Chaffin	3/10/22, 12:01:15 PM	3/10/22, 12:33:07 PM	31m 51s	cchaffin@agora.org	Presenter	
Carmen Riggle	3/10/22, 12:08:14 PM	3/10/22, 12:21:07 PM	12m 52s	criggle@agora.org	Presenter	
Janet Ulewicz	3/10/22, 12:12:35 PM	3/10/22, 12:21:53 PM	9m 18s	julewicz@agora.org	Presenter	

---

# Agenda

- IEP Analysis
- Case Study 1
- Case Study 2
- LEA Resources



1225280\_MS. ERINN SLACKTISH\_AGORA TEACHER

AGORA ADMIN (Moderator)  
Dieter\_Brittany Kieffer (Participant)  
Heather McCormick (Participant)  
Mindy Wesley (Participant)  
Mike Scheirer (Participant)  
Erinn Slacktish (Moderator)  
Katie Wright (Participant)  
Kozar\_Angela Bayly (Participant)  
Morgan Witman (Participant)  
Kozar\_Liz McEwen (Participant)  
Holly Allen (Participant)  
Jen Fisher (Moderator)  
Maryann Johnson (Moderator)  
Valerie Natale (Moderator)  
Dieter\_Kayla Flores (Participant)  
Fisher\_Cukauskas\_Michelle (Moderator)  
Susan Detwiler (Participant)  
Crystal Long (Participant)  
Melissa Patterson (Participant)  
Heather Bianconi (Participant)  
Candace Kreutzer (Participant)  
Frank Nagy (Participant)  
Dieter\_Jennifer McGinty (Participant)  
John Thomas (Participant)  
Jen Lucia (Moderator)  
Val Volpe (Participant)  
Hornbake\_Jim Montgomery (Participant)  
Butler\_Amanda Harbaugh (Participant)  
Regan Shebeck (Participant)  
Erin Hilson (Participant)  
Butler\_Jansen Hornbake (Participant)  
Colleen Freyvogel (Moderator)  
Steve Nugent (Participant)  
Butler\_Lauren Shaffer (Participant)  
Laura Goldman (Participant)  
Freyvogel\_Whitney Bargerstock (Participant)  
Hornbake\_Denise Curry (Participant)  
Hornbake\_Kristie Hawk (Participant)  
Jeff Miller (Participant)  
Hornbake\_Mike Floyd (Participant)  
Steve Calabro (Participant)  
Hornbake\_Jamie Grant (Participant)  
Schall\_Michelle Olsavsky (Participant)

# Thank you for coming today!



Melanie Stanforth, Agora  
Speech Pathologist

Joe Passante - Related  
Services Coordinator

We're going to talk about:

- Related services in schools (specifically at Agora)
- What to do with related services as your year begins

1. Summary						
Attended participants	60					
Start time	8/20/21, 9:35:14 AM					
End time	8/20/21, 11:19:39 AM					
Meeting duration	1h 44m 26s					
Average attendance time	1h 3m 29s					
2. Participants						
Name	First join	Last leave	In-meeting duration	Email	Participant ID (UPN)	Role
Melanie Stanforth	8/20/21, 9:41:24 AM	8/20/21, 11:13:17 AM	1h 31m 53s	mstanforth@agora.org	mstanforth@agora.org	Presenter
Ms. Andaiye Hall (Guest)	8/20/21, 9:41:26 AM	8/20/21, 11:12:43 AM	1h 31m 17s			Attendee
Joseph Passante	8/20/21, 9:45:58 AM	8/20/21, 11:12:58 AM	1h 27m	jpassante@agora.org	jpassante@agora.org	Organizer
Aaron Schuschu	8/20/21, 9:49:36 AM	8/20/21, 11:02:11 AM	1h 12m 34s			Attendee
Daril Bradley (Guest)	8/20/21, 9:50:14 AM	8/20/21, 11:12:52 AM	1h 22m 38s			Attendee
Amirah McIntyre	8/20/21, 9:53:21 AM	8/20/21, 11:13:04 AM	1h 19m 42s	amcintyre@agora.org	amcintyre@agora.org	Presenter
admin@keppleybehavioralconsulting.com (Guest)	8/20/21, 9:58:06 AM	8/20/21, 11:09:58 AM	1h 11m 52s			Attendee
Stephanie Siko (Guest)	8/20/21, 9:58:07 AM	8/20/21, 11:09:41 AM	1h 11m 33s			Attendee
Music Therapy Associates (Guest)	8/20/21, 9:58:16 AM	8/20/21, 11:10:03 AM	1h 11m 46s			Attendee
Paula- US Healthcare Services (Guest)	8/20/21, 9:58:19 AM	8/20/21, 11:12:52 AM	1h 14m 32s			Attendee
Erin Nock	8/20/21, 9:58:19 AM	8/20/21, 11:11:28 AM	1h 13m 8s	enock@eastersealswcpenna.org	enock@eastersealswcpenna.org	Attendee
lynette waldron (Guest)	8/20/21, 9:58:19 AM	8/20/21, 11:10:06 AM	1h 11m 47s			Attendee
Mrs. Jennifer Young IA/PCA Therapist	8/20/21, 9:58:19 AM	8/20/21, 11:09:49 AM	1h 11m 30s			Attendee
Nicole Stockton	8/20/21, 9:58:20 AM	8/20/21, 11:12:07 AM	1h 13m 47s	nstockton@attainaba.com	nstockton@attainaba.com	Attendee
Yolanda Coleman (Guest)	8/20/21, 9:58:20 AM	8/20/21, 11:10:18 AM	1h 11m 57s			Attendee
Logen Fogal (Guest)	8/20/21, 9:58:20 AM	8/20/21, 11:13:06 AM	1h 14m 46s			Attendee
Romano, Cara	8/20/21, 9:58:20 AM	8/20/21, 11:09:35 AM	1h 11m 14s	cara.romano@goodwillswpa.org	cara.romano@goodwillswpa.org	Attendee
Cynthia Phifer	8/20/21, 9:58:21 AM	8/20/21, 10:55:14 AM	56m 52s	cphifer@universalcompanies.org	cphifer@universalcompanies.org	Attendee
U.S. Healthcare Services (Guest)	8/20/21, 9:58:21 AM	8/20/21, 11:10:09 AM	1h 11m 47s			Attendee
Patrick Rein (PCA) (Guest)	8/20/21, 9:58:21 AM	8/20/21, 11:13:30 AM	1h 15m 8s			Attendee
	14128629631	8/20/21, 9:58:21 AM	8/20/21, 11:10:12 AM			Attendee
Morgan Wheeler (Guest)	8/20/21, 9:58:52 AM	8/20/21, 11:09:41 AM	1h 10m 48s			Attendee
Carrie Hughes (Guest)	8/20/21, 9:58:52 AM	8/20/21, 11:12:46 AM	1h 13m 53s			Attendee
Lindsey Callado (Guest)	8/20/21, 9:58:53 AM	8/20/21, 11:10:23 AM	1h 11m 29s			Attendee
Support Brands (Guest)	8/20/21, 9:58:59 AM	8/20/21, 10:17:57 AM	18m 58s			Attendee
Lauren Rowe	8/20/21, 9:59:02 AM	8/20/21, 11:09:50 AM	1h 10m 48s	lrowe@living-unlimitedinc.com	lrowe@living-unlimitedinc.com	Attendee
JaTanna Parrish	8/20/21, 9:59:13 AM	8/20/21, 11:10:13 AM	1h 11m	jparrish@living-unlimitedinc.com	jparrish@living-unlimitedinc.com	Attendee
Kelsey (Guest)	8/20/21, 9:59:32 AM	8/20/21, 11:00:23 AM	1h 50s			Attendee
Katie Ruffner (Guest)	8/20/21, 9:59:33 AM	8/20/21, 11:09:57 AM	1h 10m 23s			Attendee
Amber Laylon	8/20/21, 9:59:43 AM	8/20/21, 10:58:27 AM	58m 43s	alaylon@living-unlimitedinc.com	alaylon@living-unlimitedinc.com	Attendee
Eileen H. Council	8/20/21, 10:00:22 AM	8/20/21, 11:12:59 AM	1h 12m 37s	Eileen.H.Council@MeetCTP.com	Eileen.H.Council@MeetCTP.com	Attendee
Jessica Williamson	8/20/21, 10:00:25 AM	8/20/21, 11:09:42 AM	1h 9m 17s	jwilliamson@abasupportservices.com	jwilliamson@abasupportservices.com	Attendee
Maria Marcum (Guest)	8/20/21, 10:00:31 AM	8/20/21, 11:09:48 AM	1h 9m 16s			Attendee
Susan Adisa	8/20/21, 10:00:39 AM	8/20/21, 11:09:59 AM	1h 8m 11s	sadisa@attainaba.com	sadisa@attainaba.com	Attendee
Brielle (Guest)	8/20/21, 10:00:52 AM	8/20/21, 10:10:03 AM	9m 10s			Attendee
Christina K. Sampson	8/20/21, 10:01:00 AM	8/20/21, 11:10:10 AM	1h 9m 9s	Christina.K.Sampson@MeetCTP.com	Christina.K.Sampson@MeetCTP.com	Attendee
Erinn Slacktish	8/20/21, 10:01:07 AM	8/20/21, 11:10:14 AM	1h 9m 7s	eslacktish@agora.org	eslacktish@agora.org	Attendee
Cari Tomczyk	8/20/21, 10:01:13 AM	8/20/21, 11:13:31 AM	1h 12m 18s	Cari.Tomczyk@MeetCTP.com	Cari.Tomczyk@MeetCTP.com	Attendee



Jennifer Fisher Clark	8/20/21, 10:01:14 AM	8/20/21, 11:09:50 AM	1h 8m 36s	jclark@agora.org	jclark@agora.org	Attendee
christina johnson (Guest)	8/20/21, 10:01:55 AM	8/20/21, 11:10:30 AM	1h 8m 34s			Attendee
Azkiyah Hall (Guest)	8/20/21, 10:02:03 AM	8/20/21, 10:20:52 AM	18m 49s			Attendee
Mike (Guest)	8/20/21, 10:02:10 AM	8/20/21, 11:09:50 AM	1h 7m 39s			Attendee
Brianna T. Peterson	8/20/21, 10:02:16 AM	8/20/21, 10:57:28 AM	55m 11s	Brianna.T.Peterson@MeetCTP.com	Brianna.T.Peterson@MeetCTP.com	Attendee
Laura Draghiciu	8/20/21, 10:02:37 AM	8/20/21, 11:09:45 AM	1h 7m 8s	LauraD@txsource.com	LauraD@txsource.com	Attendee
Lisa A. Kowalski	8/20/21, 10:02:37 AM	8/20/21, 11:09:37 AM	1h 6m 59s	Lisa.A.Kowalski@MeetCTP.com	Lisa.A.Kowalski@MeetCTP.com	Attendee
Nicole M. Nies	8/20/21, 10:02:40 AM	8/20/21, 11:13:02 AM	1h 7m 42s	Nicole.M.Yencho@MeetCTP.com	Nicole.M.Yencho@MeetCTP.com	Attendee
Braelyn Beaver	8/20/21, 10:03:26 AM	8/20/21, 11:09:36 AM	1h 6m 9s	bbeaver@easterseals-sepa.org	bbeaver@easterseals-sepa.org	Attendee
Amy P. Ronen	8/20/21, 10:03:32 AM	8/20/21, 11:09:56 AM	1h 6m 24s	Amy.P.Ronen@MeetCTP.com	Amy.P.Ronen@MeetCTP.com	Attendee
Amber S.	8/20/21, 10:04:23 AM	8/20/21, 11:10:31 AM	1h 6m 8s			Attendee
Paulette Hall (Guest)	8/20/21, 10:06:19 AM	8/20/21, 10:20:52 AM	14m 33s			Attendee
Azkiyah Hall (Guest)	8/20/21, 10:06:21 AM	8/20/21, 11:19:39 AM	1h 13m 18s			Attendee
19084720117	8/20/21, 10:09:35 AM	8/20/21, 11:02:25 AM	52m 50s			Attendee
Bobbie Jo Thompson (Guest)	8/20/21, 10:10:03 AM	8/20/21, 11:09:51 AM	59m 47s			Attendee
Brielle (Guest)	8/20/21, 10:10:28 AM	8/20/21, 11:10:06 AM	59m 37s			Attendee
Valerie Natale	8/20/21, 10:11:43 AM	8/20/21, 11:09:55 AM	58m 12s	vnatale@agora.org	vnatale@agora.org	Attendee
Paulette Hall (Guest)	8/20/21, 10:14:27 AM	8/20/21, 11:12:49 AM	58m 22s			Attendee
Maryann Johnson	8/20/21, 10:16:21 AM	8/20/21, 10:16:51 AM	30s	majohnson@agora.org	majohnson@agora.org	Attendee
Cara (Guest)	8/20/21, 10:18:35 AM	8/20/21, 11:10:11 AM	51m 35s			Attendee
Jessica Noel (Guest)	8/20/21, 10:41:18 AM	8/20/21, 11:10:02 AM	28m 44s			Attendee
Michelle Cukauskas	8/20/21, 10:41:54 AM	8/20/21, 11:10:04 AM	28m 9s	mcukauskas@agora.org	mcukauskas@agora.org	Attendee
3. In-Meeting activities						
Name	Join time	Leave time	Duration	Email	Role	
Melanie Stanforth	8/20/21, 9:41:24 AM	8/20/21, 11:13:17 AM	1h 31m 53s	mstanforth@agora.org	Presenter	
Ms. Andaiye Hall (Guest)	8/20/21, 9:41:26 AM	8/20/21, 11:12:43 AM	1h 31m 17s		Attendee	
Joseph Passante	8/20/21, 9:45:58 AM	8/20/21, 11:12:58 AM	1h 27m	jpassante@agora.org	Organizer	
Aaron Schuschu	8/20/21, 9:49:36 AM	8/20/21, 11:02:11 AM	1h 12m 34s		Attendee	
Daril Bradley (Guest)	8/20/21, 9:50:14 AM	8/20/21, 11:12:52 AM	1h 22m 38s		Attendee	
Amirah McIntyre	8/20/21, 9:53:21 AM	8/20/21, 11:13:04 AM	1h 19m 42s	amcintyre@agora.org	Presenter	
admin@keppleybehavioralconsulting.com (Guest)	8/20/21, 9:58:06 AM	8/20/21, 11:09:58 AM	1h 11m 52s		Attendee	
Stephanie Siko (Guest)	8/20/21, 9:58:07 AM	8/20/21, 11:09:41 AM	1h 11m 33s		Attendee	
Music Therapy Associates (Guest)	8/20/21, 9:58:16 AM	8/20/21, 11:10:03 AM	1h 11m 46s		Attendee	
Paula- US Healthcare Services (Guest)	8/20/21, 9:58:19 AM	8/20/21, 11:12:52 AM	1h 14m 32s		Attendee	
Erin Nock	8/20/21, 9:58:19 AM	8/20/21, 11:11:28 AM	1h 13m 8s	enock@eastersealswcpenna.org	Attendee	
lynette waldron (Guest)	8/20/21, 9:58:19 AM	8/20/21, 11:10:06 AM	1h 11m 47s		Attendee	
Mrs. Jennifer Young IA/PCA Therapist	8/20/21, 9:58:19 AM	8/20/21, 11:09:49 AM	1h 11m 30s		Attendee	
Nicole Stockton	8/20/21, 9:58:20 AM	8/20/21, 11:12:07 AM	1h 13m 47s	nstockton@attainaba.com	Attendee	
Yolanda Coleman (Guest)	8/20/21, 9:58:20 AM	8/20/21, 11:10:18 AM	1h 11m 57s		Attendee	
Logen Fogal (Guest)	8/20/21, 9:58:20 AM	8/20/21, 11:13:06 AM	1h 14m 46s		Attendee	
Romano, Cara	8/20/21, 9:58:20 AM	8/20/21, 11:09:35 AM	1h 11m 14s	cara.romano@goodwillswpa.org	Attendee	
Cynthia Phifer	8/20/21, 9:58:21 AM	8/20/21, 10:55:14 AM	56m 52s	cphifer@universalcompanies.org	Attendee	
U.S. Healthcare Services (Guest)	8/20/21, 9:58:21 AM	8/20/21, 11:10:09 AM	1h 11m 47s		Attendee	
Patrick Rein (PCA) (Guest)	8/20/21, 9:58:21 AM	8/20/21, 11:13:30 AM	1h 15m 8s		Attendee	
14128629631	8/20/21, 9:58:21 AM	8/20/21, 11:10:12 AM	1h 11m 50s		Attendee	
Morgan Wheeler (Guest)	8/20/21, 9:58:52 AM	8/20/21, 11:09:41 AM	1h 10m 48s		Attendee	

Carrie Hughes (Guest)	8/20/21, 9:58:52 AM	8/20/21, 11:12:46 AM	1h 13m 53s		Attendee
Lindsey Callado (Guest)	8/20/21, 9:58:53 AM	8/20/21, 11:10:23 AM	1h 11m 29s		Attendee
Support Brands (Guest)	8/20/21, 9:58:59 AM	8/20/21, 10:17:57 AM	18m 58s		Attendee
Lauren Rowe	8/20/21, 9:59:02 AM	8/20/21, 11:09:50 AM	1h 10m 48s	lrowe@living-unlimitedinc.com	Attendee
JaTanna Parrish	8/20/21, 9:59:13 AM	8/20/21, 11:10:13 AM	1h 11m	jparrish@living-unlimitedinc.com	Attendee
Kelsey (Guest)	8/20/21, 9:59:32 AM	8/20/21, 11:00:23 AM	1h 50s		Attendee
Katie Ruffner (Guest)	8/20/21, 9:59:33 AM	8/20/21, 11:09:57 AM	1h 10m 23s		Attendee
Amber Laylon	8/20/21, 9:59:43 AM	8/20/21, 10:58:27 AM	58m 43s	alaylon@living-unlimitedinc.com	Attendee
Eileen H. Council	8/20/21, 10:00:22 AM	8/20/21, 11:12:59 AM	1h 12m 37s	Eileen.H.Council@MeetCTP.com	Attendee
Jessica Williamson	8/20/21, 10:00:25 AM	8/20/21, 11:09:42 AM	1h 9m 17s	jwilliamson@abasupportservices.com	Attendee
Maria Marcum (Guest)	8/20/21, 10:00:31 AM	8/20/21, 11:09:48 AM	1h 9m 16s		Attendee
Susan Adisa	8/20/21, 10:00:39 AM	8/20/21, 10:02:45 AM	2m 5s	sadisa@attainaba.com	Attendee
Susan Adisa	8/20/21, 10:03:52 AM	8/20/21, 11:09:59 AM	1h 6m 6s	sadisa@attainaba.com	Attendee
Brielle (Guest)	8/20/21, 10:00:52 AM	8/20/21, 10:10:03 AM	9m 10s		Attendee
Brielle (Guest)	8/20/21, 10:10:28 AM	8/20/21, 11:10:06 AM	59m 37s		Attendee
Christina K. Sampson	8/20/21, 10:01:00 AM	8/20/21, 11:10:10 AM	1h 9m 9s	Christina.K.Sampson@MeetCTP.com	Attendee
Erinn Slacktish	8/20/21, 10:01:07 AM	8/20/21, 11:10:14 AM	1h 9m 7s	eslacktish@agora.org	Attendee
Cari Tomczyk	8/20/21, 10:01:13 AM	8/20/21, 11:13:31 AM	1h 12m 18s	Cari.Tomczyk@MeetCTP.com	Attendee
Jennifer Fisher Clark	8/20/21, 10:01:14 AM	8/20/21, 11:09:50 AM	1h 8m 36s	jclark@agora.org	Attendee
christina johnson (Guest)	8/20/21, 10:01:55 AM	8/20/21, 11:10:30 AM	1h 8m 34s		Attendee
Azkiyah Hall (Guest)	8/20/21, 10:02:03 AM	8/20/21, 10:20:52 AM	18m 49s		Attendee
Azkiyah Hall (Guest)	8/20/21, 10:06:21 AM	8/20/21, 11:19:39 AM	1h 13m 18s		Attendee
Mike (Guest)	8/20/21, 10:02:10 AM	8/20/21, 11:09:50 AM	1h 7m 39s		Attendee
Brianna T. Peterson	8/20/21, 10:02:16 AM	8/20/21, 10:57:28 AM	55m 11s	Brianna.T.Peterson@MeetCTP.com	Attendee
Laura Draghiciu	8/20/21, 10:02:37 AM	8/20/21, 11:09:45 AM	1h 7m 8s	LauraD@txsource.com	Attendee
Lisa A. Kowalski	8/20/21, 10:02:37 AM	8/20/21, 11:09:37 AM	1h 6m 59s	Lisa.A.Kowalski@MeetCTP.com	Attendee
Nicole M. Nies	8/20/21, 10:02:40 AM	8/20/21, 11:09:59 AM	1h 7m 18s	Nicole.M.Yencho@MeetCTP.com	Attendee
Nicole M. Nies	8/20/21, 11:12:38 AM	8/20/21, 11:13:02 AM	24s	Nicole.M.Yencho@MeetCTP.com	Attendee
Braelyn Beaver	8/20/21, 10:03:26 AM	8/20/21, 11:09:36 AM	1h 6m 9s	bbeaver@easterseals-sepa.org	Attendee
Amy P. Ronen	8/20/21, 10:03:32 AM	8/20/21, 11:09:56 AM	1h 6m 24s	Amy.P.Ronen@MeetCTP.com	Attendee
Amber S.	8/20/21, 10:04:23 AM	8/20/21, 11:10:31 AM	1h 6m 8s		Attendee
Paulette Hall (Guest)	8/20/21, 10:06:19 AM	8/20/21, 10:20:52 AM	14m 33s		Attendee
	19084720117	8/20/21, 10:09:35 AM	8/20/21, 11:02:25 AM	52m 50s	
Bobbie Jo Thompson (Guest)	8/20/21, 10:10:03 AM	8/20/21, 11:09:51 AM	59m 47s		Attendee
Valerie Natale	8/20/21, 10:11:43 AM	8/20/21, 11:09:55 AM	58m 12s	vnatale@agora.org	Attendee
Paulette Hall (Guest)	8/20/21, 10:14:27 AM	8/20/21, 11:12:49 AM	58m 22s		Attendee
Maryann Johnson	8/20/21, 10:16:21 AM	8/20/21, 10:16:51 AM	30s	majohnson@agora.org	Attendee
Cara (Guest)	8/20/21, 10:18:35 AM	8/20/21, 11:10:11 AM	51m 35s		Attendee
Jessica Noel (Guest)	8/20/21, 10:41:18 AM	8/20/21, 11:10:02 AM	28m 44s		Attendee
Michelle Cukauskas	8/20/21, 10:41:54 AM	8/20/21, 11:10:04 AM	28m 9s	mcukauskas@agora.org	Attendee

# Agenda

- ▶ Why should you know how to utilize Easy Trac?
- ▶ What information should you have handy before logging in?
- ▶ How do you log into Easy Trac
- ▶ How do you access a student?
- ▶ Select the correct student
- ▶ How do I find information-Option A
- ▶ How do I find information-Option B
- ▶ WAIT! What if I see more than one therapist?
- ▶ Related services tab
- ▶ How do I run a service report for a related service?
- ▶ Service Report Sample
- ▶ Running Service Documentation Review Report
- ▶ Documenting contact in EasyTrac
- ▶ Communication with Therapist
- ▶ Sample introduction email
- ▶ Monthly email
- ▶ Thank you!!

<b>Timestamp</b>	<b>Email Address</b>	<b>First Name</b>
8/10/2021 12:41:39	bstevens2@agora.org	Brett
8/10/2021 13:25:00	jshaffer3@agora.org	Janelle
8/11/2021 12:09:17	tkozak@agora.org	Tamara
8/11/2021 13:30:24	klapsker@agora.org	Kristina
8/11/2021 13:33:11	svietmeier@agora.org	Stacy
8/11/2021 14:32:10	matwood@agora.org	Maree
8/11/2021 15:40:36	asweeney@agora.org	Allison
8/11/2021 23:18:04	bcantwell@agora.org	Brittney
8/12/2021 10:52:15	mlove@agora.org	Melissa
8/12/2021 16:28:26	lbrestensky@agora.org	Lisa
8/12/2021 16:54:27	nreimers@agora.org	Nancy
8/13/2021 10:03:32	hsilberman@agora.org	Heather
8/13/2021 11:42:53	jbuss@agora.org	Jennifer
8/13/2021 12:46:01	cbyers@agora.org	Colien
8/13/2021 15:17:44	rperri@agora.org	Renee
8/13/2021 16:09:09	jdepietro@agora.org	Jennifer
8/13/2021 20:55:21	dpacolay@agora.org	Dana
8/14/2021 21:00:04	slelko@agora.org	Susan
8/14/2021 23:33:14	akimmage@agora.org	Amanda
8/14/2021 23:36:05	akimmage@agora.org	Amanda
8/15/2021 17:08:50	alarge@agora.org	Allison
8/16/2021 0:00:14	akammermeier@agora.org	Amanda
8/16/2021 7:41:06	jhuffman@agora.org	Jena
8/16/2021 10:07:08	lstapf@agora.org	Laura
8/16/2021 10:07:23	sbonniger@agora.org	Samantha
8/16/2021 13:10:32	abrisbane@agora.org	Amber
8/16/2021 15:11:18	rcarmichael@agora.org	Rachel
8/16/2021 16:20:27	mstump@agora.org	Melissa
8/16/2021 16:36:23	criggle@agora.org	Carmen
8/16/2021 16:38:21	jbuckwalter@agora.org	JoDeen
8/17/2021 8:34:25	jdeemer@agora.org	Judith

<b>Timestamp</b>	<b>Email Address</b>	<b>First Name</b>
8/17/2021 9:49:26	molsavsky@agora.org	Michelle
8/17/2021 10:22:34	aarmstrong@agora.org	Amanda
8/17/2021 10:37:49	nkrol@agora.org	Nicole
8/17/2021 11:08:31	cmack@agora.org	Cathryn
8/17/2021 11:59:25	cbarkley@agora.org	Cortney
8/17/2021 12:04:49	cbarkley@agora.org	Cortney
8/17/2021 12:09:28	twalker@agora.org	Tara
8/17/2021 14:32:09	astaley2@agora.org	Amber
8/17/2021 21:29:27	jmoyer2@agora.org	Jill
8/17/2021 21:31:29	asalimbene@agora.org	Ashley
8/18/2021 0:06:29	kodonnell@agora.org	Katie
8/18/2021 8:21:57	tdraeger@agora.org	Theresa
8/18/2021 10:23:15	jflatley@agora.org	Jennifer
8/18/2021 11:59:35	cpanchura@agora.org	Chelsey
8/18/2021 12:01:16	cemrick@agora.org	Carissa
8/18/2021 13:43:54	bpontious@agora.org	Brianna
8/18/2021 13:55:32	dodonnell@agora.org	Dana
8/18/2021 13:58:33	dodonnell@agora.org	Dana
8/18/2021 14:02:16	jbeeken@agora.org	Jennifer
8/18/2021 15:23:10	mgaso@agora.org	Melissa
8/18/2021 18:03:07	skennedy@agora.org	Sabrina
8/18/2021 18:08:31	skennedy@agora.org	Sabrina
8/19/2021 7:53:35	mfranklin@agora.org	Melissa
8/19/2021 8:27:17	cwiddop@agora.org	Christen
8/19/2021 11:22:23	bcooper@agora.org	Barb
8/19/2021 13:50:04	tambuka@agora.org	Tracey
8/19/2021 13:54:06	tambuka@agora.org	Tracey
8/19/2021 14:08:38	gkaufman@agora.org	Gillian
8/19/2021 14:09:56	jbarnhart@agora.org	Jessica
8/19/2021 14:14:18	aschmidt@agora.org	Ashley

<b>Timestamp</b>	<b>Email Address</b>	<b>First Name</b>
8/19/2021 14:15:03	afarster@agora.org	Ashley
8/19/2021 14:54:30	adenham@agora.org	Angela
8/19/2021 15:28:35	gmattox@agora.org	Gemma
8/19/2021 16:04:26	lsvonavec@agora.org	Lauren
8/19/2021 23:00:42	gdonch@agora.org	Gina
8/20/2021 7:34:08	khumanick@agora.org	Kymberly
8/20/2021 9:33:01	eslacktish@agora.org	Erinn
8/20/2021 9:49:03	llamison@agora.org	Lauren
8/20/2021 11:38:46	gmallon@agora.org	Gina
8/20/2021 12:02:12	sadams@agora.org	Serena
8/20/2021 12:10:11	sadams@agora.org	Serena
8/20/2021 12:42:03	mpatterson@agora.org	Melissa
8/20/2021 14:08:48	araught@agora.org	Amy
8/20/2021 15:21:12	lspratt@agora.org	Leslie
8/20/2021 15:29:10	lspratt@agora.org	Leslie
8/20/2021 15:58:29	jscadieux@agora.org	Jennifer
8/20/2021 17:13:32	kshannon@agora.org	Keri
8/20/2021 18:55:27	mbasso@agora.org	Maura Basso
8/20/2021 22:55:02	lkerns@agora.org	Lauren
8/21/2021 20:24:52	mgarczynski@agora.org	Molly
8/21/2021 23:26:39	rcongdon@agora.org	Rebekah
8/22/2021 11:24:32	escrip@agora.org	Erin
8/22/2021 11:51:22	slipiec@agora.org	Susan
8/22/2021 15:27:21	kwelsh@agora.org	Kristy
8/22/2021 16:07:39	lradico@agora.org	Lauren
8/22/2021 20:04:08	kplatt@agora.org	Keith
8/22/2021 22:33:21	bfroehlich@agora.org	Brittany
8/23/2021 0:41:04	cbaker@agora.org	Chris
8/23/2021 7:48:58	jzollman@agora.org	Jennifer
8/23/2021 8:28:14	vjackson@agora.org	Veronica

<b>Timestamp</b>	<b>Email Address</b>	<b>First Name</b>
8/23/2021 9:30:52	kamodeo@agora.org	Kattreena
8/23/2021 13:01:05	lsavitz@agora.org	Lisa
8/23/2021 13:27:45	abaranoski@agora.org	Anna
8/23/2021 14:21:12	kcostanzo@agora.org	Kristal
8/23/2021 14:22:44	cthomas@agora.org	Christi
8/24/2021 11:19:44	bellis@agora.org	Bridget
8/24/2021 11:23:10	bellis@agora.org	Bridget
8/24/2021 14:17:59	syoung@agora.org	Sasha
8/26/2021 8:58:43	dfurka@agora.org	David
8/26/2021 9:01:27	dfurka@agora.org	David
8/26/2021 11:23:06	kpaolino@agora.org	Kimberly
8/26/2021 11:24:32	breamer@agora.org	Brittany
8/26/2021 11:48:10	jlinderman@agora.org	Jessica
8/26/2021 17:45:34	jdoebereiner@agora.org	Julie
8/27/2021 15:34:24	khoffman@agora.org	Kaelyn
8/29/2021 22:53:54	jreese@agora.org	Jessica
8/30/2021 12:03:58	tbash@agora.org	Theresa
8/30/2021 12:09:52	tbash@agora.org	Theresa
8/30/2021 12:13:00	tbash@agora.org	Theresa
9/1/2021 12:21:18	mmccracken@agora.org	Melissa
9/1/2021 12:23:15	rkubica@agora.org	Regina
9/1/2021 12:39:03	shoffmaster@agora.org	Shannon
9/1/2021 15:52:54	smarcello@agora.org	Stefanie

## **TODAY, WE WILL**

- ❖ **Highlight IEP Meeting Tips.**
  - ❖ **Highlight Legal Tips.**
  - ❖ **Review IEP documents and highlight important items to look for.**
  - ❖ **Share the IEP analysis for your use and IEP writing guide for your reference.**
  - ❖ **Highlight COVID items.**
  - ❖ **Answer general questions.**
- 

## **Today, you will**

- ❖ **Listen, ask and Learn!**
- ❖ **Respond to Questions**
- ❖ **Learn and Grow as an LEA.**
- ❖ **Have fun!**



## Tracking



Erinn Slacktish  
Organizer



6 Accepted 1 Declined



Tonya Smith  
Accepted



Bridget Kozar  
Accepted



Marie Williams  
Accepted



Danielle Schall  
Accepted



Gina Szczepkowski  
Accepted



Melissa Hale-Patterson  
Declined



Katy Giovanisci, Ed.D  
Unknown



Denise Curry  
Unknown



Katie Wright  
Unknown



Laurie Super  
Unknown



Robin Hartman  
Unknown



Jamie Grant  
Unknown



Jansen Hornbake  
Unknown



Lauren Shaffer  
Unknown



Lauren Wilson  
Unknown



Michelle Cukauskas  
Unknown



Kristie Hawk  
Unknown



John Butler  
Unknown



Kayla Flores  
Unknown



Jesse Capitano  
Unknown



Colleen Freyvogel Bruss  
Unknown



Kimberly Fiscus  
Unknown



Whitney Bargerstock  
Unknown



Candace Kreutzer  
Unknown



James Montgomery  
Unknown



Brittany Kieffer  
Unknown



Amanda Harbaugh  
Unknown



Colleen Richardson  
Unknown



Jennifer Fisher Clark  
Unknown



Anna Lepsch  
Unknown



Maryann Johnson  
Unknown



Alina Kitchell  
Unknown



John Thomas  
Unknown



ERIC BUFFINGTON  
Unknown



HEATHER BIANCONI  
Unknown



Alyson Scheib  
Unknown



Angela Bayly  
Unknown



Susan Detwiler  
Unknown



Elizabeth McEwen  
Unknown



Jen Lucia  
Unknown



Melissa Jusko  
Unknown



Rebecca Adams  
Unknown



gsczepakowski@agora.org  
Unknown



Crystal Long  
Unknown



Heather McCormick  
Unknown



Michael Floyd  
Unknown



Julie McCrea  
Unknown



Regan Shebeck  
Unknown



Jeffrey Miller  
Unknown



Laura Goldman  
Unknown



Mindy Wesley  
Unknown



Jennifer McGinty  
Unknown



Holly Allen  
Unknown



Tara Quisito  
Unknown



Stephen Nugent  
Unknown



joreiley@agora.org  
Unknown



Kimberly McLaughlin  
Unknown



Caleb Cragle  
Unknown



Michelle Olsavsky  
Unknown



Erin Hilson  
Unknown



Pamela Keth  
Unknown



Katherine DiStefano  
Unknown



Morgan Witman  
Unknown



Val Natale  
Unknown



Anne Butler, Ed.D  
Unknown



Jaclyn O'Reilly  
Unknown



Michael Scheirer  
Unknown

**Optional**



Brianne Ryen  
Accepted

# Meeting Agenda

- Advisory
- General Information
- Schedule
- Asynchronous Expectations
- Baseline and Progress Monitoring
- PLC
- Input Forms
- Lesson Plans
- Supplemental Programs
- Interventions
- Walkthroughs and Observations





# Our Academic Resource Room Team

Resource Room Teacher	Resource Room
JoDeen Buckwalter	Reading RR B & C
Nancy Reimers	Reading RR C & D
Katie O'Donnell	Reading RR D
Barb Cooper	Writing RR B & C
Tara Walker	Writing RR C & D
Mandi Moyer	Math RR B
Veronica Jackson	Math RR C & D
Jill Moyer	Math RR C
Jennifer Flatley	Math RR D

**Instructional Coach**

**Michelle Olsavsky**



1. Summary						
Attended participants	18					
Start time	9/3/21, 9:54:07 AM					
End time	9/3/21, 11:18:59 AM					
Meeting duration	1h 24m 52s					
Average attendance time	1h 3m					
2. Participants						
Name	First join	Last leave	In-meeting duration	Email	Participant ID (UPN)	Role
Jennifer Buss	9/3/21, 9:54:23 AM	9/3/21, 11:18:47 AM	1h 24m 24s	jbuss@agora.org	jbuss@agora.org	Presenter
Carmen Riggle	9/3/21, 9:54:41 AM	9/3/21, 11:06:20 AM	1h 11m 38s	criggle@agora.org	criggle@agora.org	Presenter
Marlee Atwood	9/3/21, 9:55:10 AM	9/3/21, 11:06:35 AM	1h 11m 25s	matwood@agora.org	matwood@agora.org	Presenter
Erin Connor	9/3/21, 9:55:27 AM	9/3/21, 10:48:18 AM	52m 51s	econnor@agora.org	econnor@agora.org	Presenter
Ashley Schmidt	9/3/21, 9:58:02 AM	9/3/21, 10:57:54 AM	59m 51s	aschmidt@agora.org	aschmidt@agora.org	Presenter
Laurie Super	9/3/21, 9:58:15 AM	9/3/21, 11:18:59 AM	1h 20m 44s	lsuper@agora.org	lsuper@agora.org	Presenter
Janet Ulewicz	9/3/21, 9:58:17 AM	9/3/21, 11:06:45 AM	1h 8m 27s	julewicz@agora.org	julewicz@agora.org	Presenter
Regina Mallon	9/3/21, 9:58:40 AM	9/3/21, 11:08:58 AM	1h 10m 18s	gmallon@agora.org	gmallon@agora.org	Presenter
Brittney Walczak	9/3/21, 9:59:12 AM	9/3/21, 11:06:16 AM	1h 7m 3s	bwalczak@agora.org	bwalczak@agora.org	Presenter
Ashley Farster	9/3/21, 9:59:35 AM	9/3/21, 11:08:54 AM	1h 9m 18s	afarster@agora.org	afarster@agora.org	Presenter
Whitney Bargerstock	9/3/21, 9:59:48 AM	9/3/21, 11:11:24 AM	1h 11m 35s	wbargerstock@agora.org	wbargerstock@agora.org	Presenter
Michelle Cukauskas	9/3/21, 10:00:17 AM	9/3/21, 11:18:46 AM	1h 18m 29s	mcukauskas@agora.org	mcukauskas@agora.org	Organizer
Rachel Weeks	9/3/21, 10:00:21 AM	9/3/21, 11:06:17 AM	1h 5m 55s	rweeks@agora.org	rweeks@agora.org	Presenter
Cathrine Hartman	9/3/21, 10:00:32 AM	9/3/21, 11:06:34 AM	1h 6m 1s	chartman@agora.org	chartman@agora.org	Presenter
Olivia Eckels	9/3/21, 10:00:52 AM	9/3/21, 11:07:26 AM	35m 48s	oeckels@agora.org	oeckels@agora.org	Presenter
Casey Chaffin	9/3/21, 10:00:54 AM	9/3/21, 11:05:47 AM	1h 4m 53s	cchaffin@agora.org	cchaffin@agora.org	Presenter
Stefanie Marcello	9/3/21, 10:19:57 AM	9/3/21, 11:08:53 AM	48m 55s	smarcello@agora.org	smarcello@agora.org	Presenter
John Butler	9/3/21, 11:12:09 AM	9/3/21, 11:18:46 AM	6m 36s	jbutler@agora.org	jbutler@agora.org	Presenter
3. In-Meeting activities						
Name	Join time	Leave time	Duration	Email	Role	
Jennifer Buss	9/3/21, 9:54:23 AM	9/3/21, 11:18:47 AM	1h 24m 24s	jbuss@agora.org	Presenter	
Carmen Riggle	9/3/21, 9:54:41 AM	9/3/21, 11:06:20 AM	1h 11m 38s	criggle@agora.org	Presenter	
Marlee Atwood	9/3/21, 9:55:10 AM	9/3/21, 11:06:35 AM	1h 11m 25s	matwood@agora.org	Presenter	
Erin Connor	9/3/21, 9:55:27 AM	9/3/21, 10:48:18 AM	52m 51s	econnor@agora.org	Presenter	
Ashley Schmidt	9/3/21, 9:58:02 AM	9/3/21, 10:57:54 AM	59m 51s	aschmidt@agora.org	Presenter	
Laurie Super	9/3/21, 9:58:15 AM	9/3/21, 11:18:59 AM	1h 20m 44s	lsuper@agora.org	Presenter	
Janet Ulewicz	9/3/21, 9:58:17 AM	9/3/21, 11:06:45 AM	1h 8m 27s	julewicz@agora.org	Presenter	
Regina Mallon	9/3/21, 9:58:40 AM	9/3/21, 11:08:58 AM	1h 10m 18s	gmallon@agora.org	Presenter	
Brittney Walczak	9/3/21, 9:59:12 AM	9/3/21, 11:06:16 AM	1h 7m 3s	bwalczak@agora.org	Presenter	
Ashley Farster	9/3/21, 9:59:35 AM	9/3/21, 11:08:54 AM	1h 9m 18s	afarster@agora.org	Presenter	
Whitney Bargerstock	9/3/21, 9:59:48 AM	9/3/21, 11:11:24 AM	1h 11m 35s	wbargerstock@agora.org	Presenter	

Michelle Cukauskas	9/3/21, 10:00:17 AM	9/3/21, 11:18:46 AM	1h 18m 29s	mcukauskas@agora.org	Organizer	
Rachel Weeks	9/3/21, 10:00:21 AM	9/3/21, 11:06:17 AM	1h 5m 55s	rweeks@agora.org	Presenter	
Cathrine Hartman	9/3/21, 10:00:32 AM	9/3/21, 11:06:34 AM	1h 6m 1s	chartman@agora.org	Presenter	
Olivia Eckels	9/3/21, 10:00:52 AM	9/3/21, 10:33:50 AM	32m 58s	oeckels@agora.org	Presenter	
Olivia Eckels	9/3/21, 11:04:35 AM	9/3/21, 11:07:26 AM	2m 50s	oeckels@agora.org	Presenter	
Casey Chaffin	9/3/21, 10:00:54 AM	9/3/21, 11:05:47 AM	1h 4m 53s	cchaffin@agora.org	Presenter	
Stefanie Marcello	9/3/21, 10:19:57 AM	9/3/21, 11:08:53 AM	48m 55s	smarcello@agora.org	Presenter	
John Butler	9/3/21, 11:12:09 AM	9/3/21, 11:18:46 AM	6m 36s	jbutler@agora.org	Presenter	

# Meeting Agenda

- Our Team
- Team Expectations
- Professionalism
- Team Meetings & PLC
- PTO
- Differentiated Supervision
- Advisory Welcome Calls
- General Ed. Odds and Ends
- Student Assembly Info
- Reminders
- Have a fabulous week!



## Danielle & Michelle

Teacher	Role
JoDeen Buckwalter	Reading B/C
Nancy Reimers	Reading C/D
Katie O'Donnell	Reading D
Amanda Mover	Math B
Veronica Jackson	Math C/D
Jill Mover	Math C
Jennifer Flatley	Math D
Barb Cooper	Writing B/C
Tara Walker	Writing C/D
Sasha Youna	LS & 1:1
Allison Sweeney	1-2 LS CM
Sue Lelko	1-2 LS CM
Keri Shannon	1-2 LS CM
Heather Silberman	1-2 LS CM
Jennifer Zollman	1-2 LS CM
Melissa Love	3A&B LS CM
Lynn Paaliej	3A&B LS CM
Becky Conadon	3A&B LS CM
Terri Hunkele	3A&B LS CM
Theresa Draeaer	3A&B LS CM
Lisa Savitz	3A&B LS CM
Kattreena Omodeo	3A&B LS CM
NEW LS Case Manager	1-3B LS CM

# MEET OUR TEAM

~

DANIELLE SCHALL - AD  
MICHELLE OLSAVSKY - IC

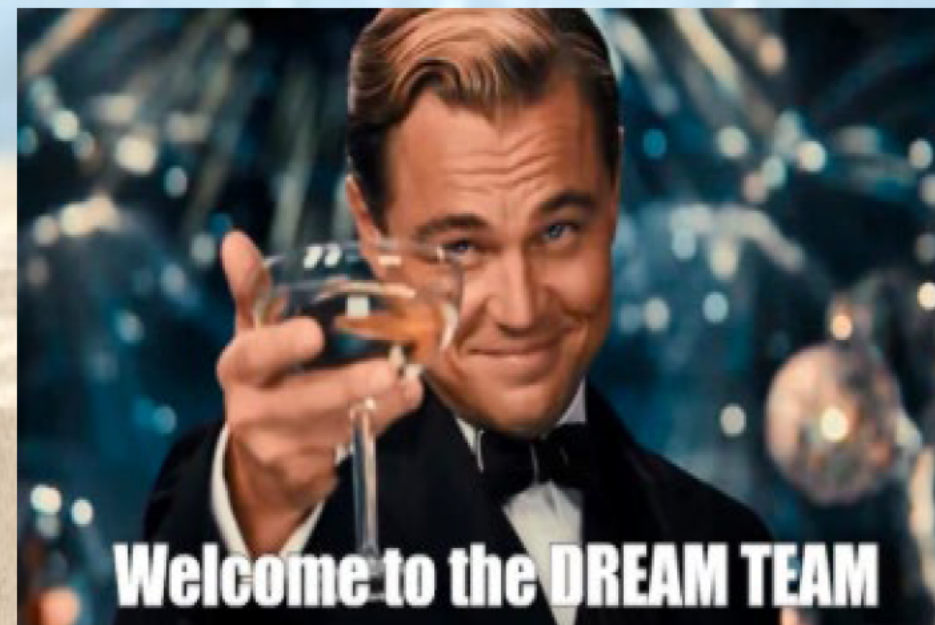

# Today's Objectives



## This session will:



- Cover IEP Writing Guide
- Distribute updated IEP Writing Guide and 2020-2021 IEP Analysis form
- Provide Measurable Annual Goal writing training

Timestamp	Email Address	Name	PPID	Supervisor	
8/11/2020 16:09:17	eslacktish@agora.org	First Name	Last Name	ANSWER KEY	
8/10/2020 16:17:54	bfroehlich@agora.org	Brittany	Froehlich	5897815	Lucia
8/11/2020 9:47:35	lolbryk@agora.org	Lacey	Olbryk	8725401	Lucia
8/11/2020 14:10:36	asweeney@agora.org	Allison	Sweeney	6797603	Natale
8/11/2020 14:39:46	cmack@agora.org	Cathryn	Mack	9457194	Johnson
8/11/2020 15:46:09	twalker@agora.org	Tara	Walker		Schall
8/11/2020 22:22:43	lsvonavec@agora.org	Lauren	Svonavec	6873915	Johnson
8/12/2020 7:39:19	bscears@agora.org	Breanne	Scears	2918713	Val Natale
8/12/2020 9:11:40	jshaffer3@agora.org	Janelle	Shaffer	1783096	Freyvogel
8/12/2020 9:15:59	kbeadle@agora.org	Karla	Beadle		Cukauskas
8/12/2020 12:09:49	jdepietro@agora.org	Jenn	DePietro	1051274	Witman
8/12/2020 12:35:02	jdeemer@agora.org	Judy	Deemer		Natale
8/12/2020 15:02:45	jbeeken@agora.org	Jennifer	Beeken	1431604	Freyvogel
8/12/2020 20:06:27	bcantwell@agora.org	Brittney	Cantwell	6989082	Johnson
8/13/2020 10:07:21	svietmeier@agora.org	Stacy	Vietmeier	5735753	Johnson
8/13/2020 10:45:26	aschmidt@agora.org	Ashley	Schmidt	6546756	Cukauskas
8/13/2020 11:28:25	cbarkley@agora.org	Cortney	Barkley	9674013	Lucia
8/13/2020 13:36:30	lstapf@agora.org	Laura	Stapf	5026504	Natale
8/13/2020 13:59:15	chartman@agora.org	Cathrine	Hartman	3606539	Cukauskas
8/13/2020 15:48:05	slelko@agora.org	Susan	Lelko	9089175	Natale
8/13/2020 15:48:19	nreimers@agora.org	Nancy	Reimers	6041706	Schall
8/14/2020 13:51:48	rperri@agora.org	Renee	Perri	1810325	Natale
8/14/2020 14:24:45	cganter@agora.org	Crysta	Ganter	1673067	Cukauskas
8/14/2020 17:38:21	lbrestensky@agora.org	Lisa	Brestensky	8491596	Freyvogel
8/14/2020 22:27:50	jreese@agora.org	Jessica	Reese	5207967	Lucia
8/17/2020 8:13:08	ckirchner@agora.org	Carly	Kirchner	6725723	Freyvogel

<b>Timestamp</b>	<b>Email Address</b>	<b>Name</b>		<b>PPID</b>	<b>Supervisor</b>
8/17/2020 10:45:27	cbryan@agora.org	Carol	Bryan	6408509	Cukauskas
8/17/2020 13:10:54	jfecik@agora.org	Justine	Fecik	1607938	Schall
8/17/2020 13:37:32	dfurka@agora.org	David	Furka	5839145	Johnson
8/17/2020 13:39:05	jhuffman@agora.org	Jena	Huffman	7165636	Natale
8/17/2020 20:06:34	klapsker@agora.org	Kristina	Lapsker		
8/18/2020 11:05:17	aarmstrong@agora.org	Amanda	Armstrong	1830841	Freyvogel
8/18/2020 11:05:19	mgaso@agora.org	Melissa	Gaso	1678431	Natale
8/18/2020 11:48:33	nkrol@agora.org	Nicole	Krol	8487304	Freyvogel
8/18/2020 12:19:35	kfitzgerald@agora.org	Kim	Fitzgerald	7953824	Lucia
8/18/2020 13:35:37	jdunlap@agora.org	Jill	Dunlap	3951391	Freyvogel
8/18/2020 13:39:38	lradico@agora.org	Lauren	Radico	5674767	Freyvogel
8/18/2020 13:57:21	dodonnell@agora.org	Dana	O'Donnell	5397505	Johnson
8/18/2020 15:21:25	oeckels@agora.org	Olivia	Eckels	1835849	Cukauskas
8/18/2020 15:38:49	slipiec@agora.org	Susan	Lipiec	7462653	Lucia
8/18/2020 15:51:27	jcapitano@agora.org	Jesse	Capitano	8981801	Freyvogel
8/18/2020 16:32:45	mstump@agora.org	Melissa	Stump	8359342	Natale
8/18/2020 17:23:11	adenham@agora.org	Angie	Denham	5837679	Witman
8/18/2020 19:19:32	kcostanzo@agora.org	Kristal	Costanzo	4721493	Lucia
8/19/2020 12:29:00	cpanchura@agora.org	Chelsey	Panchura	5735207	Freyvogel
8/19/2020 13:04:57	lspratt@agora.org	Leslie	Spratt	2579716	Johnson
8/19/2020 13:28:28	kwelsh@agora.org	Kristy	Welsh	3715812	Natale
8/19/2020 14:04:01	thunkele@agora.org	Terri	Hunkele	7871924	Schall
8/19/2020 14:17:41	jdietrich@agora.org	Jenna	Dietrich	4096064	Lucia
8/19/2020 18:33:36	astaley2@agora.org	Amber	Staley	2865256	Freyvogel
8/19/2020 20:04:12	mpelissier@agora.org	Michelle	Pelissier	1391528	Johnson
8/19/2020 20:59:44	hsilberman@agora.org	Heather	Silberman		Schall

<b>Timestamp</b>	<b>Email Address</b>	<b>Name</b>		<b>PPID</b>	<b>Supervisor</b>
8/19/2020 21:11:16	jmoyer2@agora.org	Jill	Moyer		Schall
8/20/2020 13:30:53	rcongdon@agora.org	Rebekah	Congdon	5045706	Schall
8/20/2020 21:31:40	jbarnhart@agora.org	Jessica	Barnhart	4590197	Lucia
8/21/2020 9:26:40	mlove@agora.org	Melissa	Love	1097861	Schall
8/21/2020 9:50:17	tdraeger@agora.org	Theresa	Draeger	1585189	Schall
8/21/2020 12:44:58	jzollman@agora.org	Jennifer	Zollman	8725829	Natale
8/21/2020 23:42:12	mgarczynski@agora.org	Molly	Garczynski	8048158	Johnson
8/22/2020 10:20:46	alarge@agora.org	Allison	Large	7934971	Freyvogel
8/22/2020 13:49:32	skennedy@agora.org	Sabrina	Kennedy	8258565	Natale
8/23/2020 10:02:27	lkerns@agora.org	Lauren	Kerns	6463102	Natale
8/23/2020 16:54:22	syounng@agora.org	Sasha	Young	6136347	Schall
8/23/2020 17:39:05	amalec@agora.org	Ashley	Malec	1652126	Lucia
8/23/2020 17:46:49	dpacolay@agora.org	Dana	Pacolay	5325374	Freyvogel
8/23/2020 18:00:49	jseverino@agora.org	Jill	Severino	1205208	Lucia
8/23/2020 20:09:34	abrisbane@agora.org	Amber	Brisbane	3612063	Witman
8/24/2020 4:47:10	hcobert@agora.org	Heather	Cobert	4102713	Freyvogel
8/24/2020 9:26:21	cemrick@agora.org	Carissa	Emrick	5403689	Schall
8/24/2020 10:02:30	jbuss@agora.org	Jennifer	Buss	5732496	Cukauskas
8/24/2020 10:23:14	lpagliei@agora.org	Lynn	Pagliei	3109573	Schall
8/24/2020 10:30:20	gmallon@agora.org	Regina	Mallon	1907396	Cukauskas
8/24/2020 10:31:07	afarster@agora.org	Ashley	Farster	2480142	Cukauskas
8/24/2020 11:20:45	tambuka@agora.org	Tracey	Ambuka	2941592	Freyvogel
8/24/2020 14:47:00	akimimage@agora.org	Amanda	Moyer	3056185	Schall
8/24/2020 15:18:03	gfiscus@agora.org	Grace	Fiscus	8105219	Cukauskas
8/24/2020 16:55:32	cbaker@agora.org	Chris	Baker	6760832	Lucia
8/24/2020 19:29:17	kpaolino@agora.org	Kim	Paolino	3172707	Johnson



<b>Timestamp</b>	<b>Email Address</b>	<b>Name</b>		<b>PPID</b>	<b>Supervisor</b>
8/24/2020 20:00:40	jlinderman@agora.org	Jessica	Linderman	9045025	Johnson
8/24/2020 20:06:37	cwiddop@agora.org	Christen	Widdop	6597585	Cukauskas
8/24/2020 20:12:17	bpontious@agora.org	Brianna	Pontious	9616535	Lucia
8/24/2020 21:35:20	bfink@agora.org	Brittany	Fink	9891649	Johnson
8/24/2020 23:34:43	jdoebereiner@agora.org	Julie	Doebereiner	7489562	Lucia
8/25/2020 7:09:21	lsavitz@agora.org	Lisa	Savitz	6402734	Schall
8/25/2020 7:51:17	lsavitz@agora.org	Lisa	Savitz	6402734	Schall
8/25/2020 8:16:48	gdonch@agora.org	Gina	Rodriguez	3791683	Cukauskas
8/25/2020 14:24:16	jcadieux@agora.org	Jenn	Cadieux	2746171	Freyvogel
8/25/2020 15:32:19	hdodge@agora.org	Heidi	Dodge	2569601	Johnson
8/26/2020 12:28:55	cramsey@agora.org	Cathryn	Ramsey	8190103	Lucia
8/26/2020 12:32:17	ehenretta@agora.org	Erikka	Henretta	1872897	Cukauskas
8/26/2020 12:45:28	mbasso@agora.org	Maura	Basso	6941361	Lucia
8/31/2020 13:21:53	mbotti@agora.org	Michelle	Botti	9294146	Lucia
9/1/2020 13:51:36	khoffman@agora.org	Kaelyn	Hoffman	5371396	Lucia
9/3/2020 10:23:57	kshannon@agora.org	Keri	Shannon	5341385	Natale
9/7/2020 13:21:15	bcooper@agora.org	Barb	Cooper		Schall
9/8/2020 11:11:54	mmccracken@agora.org	Melissa	McCracken	7467268	Freyvogel
9/15/2020 9:25:05	llamison@agora.org	Lauren Lamison		9614984	Natale
9/15/2020 9:46:24	scostello@agora.org	Serena Costello		6237909	Natale
9/15/2020 11:00:20	nhollenbach@agora.org	Nicolette Hollenbach		5776786	Natale
9/16/2020 15:45:42	araught@agora.org	Amy Raught		4603802	Freyvogel
9/16/2020 22:36:17	tkozak@agora.org	Tamara Kozak		2986176	Natale
9/29/2020 11:14:06	hgallagher@agora.org	Heather Gallagher		7959715	Natale
10/8/2020 16:17:43	akammermeier@agora.org	Amanda Kammermeier		2010834	Natale

What is one example of a formative assessment?	Academic goals have a standard, anchor, or element from the curriculum framework. This standard should:	Related service goals	Performance criteria does not include	When setting up your sub folder what is something you should not include?	For substitute coverage I have to do the following at least 48 hours in advance:
Classroom test scores	should be on the student's	Must have all 4 parts of th	clearly defined behavior	prior year's information	Create a folder with less
Classroom test scores	should be on the student's	Must have all 4 parts of th	clearly defined behavior	prior year's information	Create a folder with less
CDT	should be on the student's	Must have all 4 parts of th	clearly defined behavior	prior year's information	Email subrequest with dat
Classroom test scores	should be on the student's	Must have all 4 parts of th	clearly defined behavior	prior year's information	Email subrequest with dat
CDT	should be on the student's	Must have all 4 parts of th	an evaluation schedule	prior year's information	Email subrequest with dat
Classroom test scores	always be on the student's	Must have all 4 parts of th	clearly defined behavior	prior year's information	Create a folder with less
Classroom test scores	should be on the student's	Must have all 4 parts of th	clearly defined behavior	prior year's information	Email subrequest with dat
Classroom test scores	should be on the student's	Must have all 4 parts of th	the level of mastery	prior year's information	Create a folder with less
Classroom test scores	should be on the student's	Must have all 4 parts of th	clearly defined behavior	prior year's information	Create slides for the less
CDT	always be on the student's	Must have all 4 parts of th	clearly defined behavior	prior year's information	Create a folder with less
Classroom test scores	always be on the student's	Must have all 4 parts of th	clearly defined behavior	prior year's information	Create a folder with less
CDT	should be on the student's	Must have all 4 parts of th	clearly defined behavior	prior year's information	Email subrequest with dat
Classroom test scores	should be on the student's	Must have all 4 parts of th	clearly defined behavior	prior year's information	Create a folder with less
Classroom test scores	should be on the student's	Must have all 4 parts of th	clearly defined behavior	prior year's information	Email subrequest with dat
Classroom test scores	should be on the student's	Must have all 4 parts of th	clearly defined behavior	prior year's information	Email subrequest with dat
Classroom test scores	should be on the student's	Must have all 4 parts of th	number of times needed t	prior year's information	Create slides for the less
Classroom test scores	should be on the student's	Must have all 4 parts of th	clearly defined behavior	prior year's information	Create slides for the less
Classroom test scores	always be on the student's	Must have all 4 parts of th	an evaluation schedule	prior year's information	Email subrequest with dat
Classroom test scores	should be on the student's	Must have all 4 parts of th	clearly defined behavior	prior year's information	Create slides for the less
Classroom test scores	should be on the student's	Must have 3 parts of the l	an evaluation schedule	prior year's information	Create a folder with less
Classroom test scores	should be on the student's	Must have all 4 parts of th	clearly defined behavior	prior year's information	Email subrequest with dat
Classroom test scores	should be on the student's	Must have all 4 parts of th	clearly defined behavior	prior year's information	Email subrequest with dat
CDT	should be on the student's	Must have all 4 parts of th	an evaluation schedule	prior year's information	Email subrequest with dat
Classroom test scores	should be on the student's	Must have all 4 parts of th	clearly defined behavior	prior year's information	Create a folder with less
Classroom test scores	should be on the student's	Must have all 4 parts of th	clearly defined behavior	prior year's information	Email subrequest with dat
Classroom test scores	should be on the student's	Must have all 4 parts of th	clearly defined behavior	prior year's information	Create a folder with less
Classroom test scores	should be on the student's	Must have all 4 parts of th	clearly defined behavior	prior year's information	Create slides for the less

What is one example of a formative assessment?	Academic goals have a standard, anchor, or element from the curriculum framework. This standard should:	Related service goals	Performance criteria does not include	When setting up your sub folder what is something you should not include?	For substitute coverage I have to do the following at least 48 hours in advance:
Classroom test scores	should be on the student's	Must have all 4 parts of the MAG criteria or it is inco	prior year's information	prior year's information	Create slides for the lessc
Classroom test scores	should be on the student's	Must have 3 parts of the M	the level of mastery	prior year's information	Create slides for the lessc
Classroom test scores	always be on the student's	Must have all 4 parts of th	an evaluation schedule	prior year's information	Email subrequest with dat
Classroom test scores	should be on the student's	Must have all 4 parts of th	clearly defined behavior	prior year's information	Create a folder with lessc
Classroom test scores	should be on the student's	Must have all 4 parts of th	clearly defined behavior	prior year's information	Email subrequest with dat
CDT	should be on the student's	Must have all 4 parts of th	clearly defined behavior	prior year's information	Create slides for the lessc
CDT	should be on the student's	Must have all 4 parts of th	clearly defined behavior	prior year's information	Create slides for the lessc
PSSAs	should be on the student's	Must have all 4 parts of th	an evaluation schedule	prior year's information	Email subrequest with dat
Classroom test scores	should be on the student's	Must have all 4 parts of th	an evaluation schedule	prior year's information	Email subrequest with dat
Classroom test scores	should be on the student's	Must have all 4 parts of th	the level of mastery	prior year's information	Create slides for the lessc
Classroom test scores	should be on the student's	Must have all 4 parts of th	the level of mastery	prior year's information	Create slides for the lessc
Classroom test scores	always be on the student's	Must have 3 parts of the M	number of times needed t	prior year's information	Email subrequest with dat
Classroom test scores	should be on the student's	Must have all 4 parts of th	clearly defined behavior	prior year's information	Email subrequest with dat
Classroom test scores	should be on the student's	Must have all 4 parts of th	an evaluation schedule	prior year's information	Email subrequest with dat
Classroom test scores	should be on the student's	Must have all 4 parts of th	clearly defined behavior	prior year's information	Create slides for the lessc
Classroom test scores	should be on the student's	Must have all 4 parts of th	clearly defined behavior	prior year's information	Create a folder with lessc
Classroom test scores	always be on the student's	Must have all 4 parts of th	an evaluation schedule	prior year's information	Create a folder with lessc
Classroom test scores	should be on the student's	Must have all 4 parts of th	clearly defined behavior	prior year's information	Create a folder with lessc
Classroom test scores	should be on the student's	Must have all 4 parts of th	clearly defined behavior	prior year's information	Create a folder with lessc
Classroom test scores	should be on the student's	Must have all 4 parts of th	an evaluation schedule	prior year's information	Email subrequest with dat
Classroom test scores	should be on the student's	Must have all 4 parts of th	clearly defined behavior	prior year's information	Create slides for the lessc
CDT	should be on the student's	Must have all 4 parts of th	number of times needed t	prior year's information	Email subrequest with dat
Classroom test scores	should be on the student's	Must have all 4 parts of th	clearly defined behavior	prior year's information	Create slides for the lessc
Classroom test scores	should be on the student's	Must have all 4 parts of th	clearly defined behavior	prior year's information	Create a folder with lessc
Classroom test scores	always be on the student's	Must have all 4 parts of th	an evaluation schedule	prior year's information	Create a folder with lessc

What is one example of a formative assessment?	Academic goals have a standard, anchor, or element from the curriculum framework. This standard should:	Related service goals	Performance criteria does not include	When setting up your sub folder what is something you should not include?	For substitute coverage I have to do the following at least 48 hours in advance:
Classroom test scores	should be on the student's	Must have all 4 parts of th	clearly defined behavior	prior year's information	Email subrequest with dat
Classroom test scores	should be on the student's	Must have all 4 parts of th	an evaluation schedule	prior year's information	Create slides for the lessc
Classroom test scores	should be on the student's	Must have all 4 parts of th	clearly defined behavior	prior year's information	Create slides for the lessc
CDT	should be on the student's	Must have all 4 parts of th	clearly defined behavior	prior year's information	Email subrequest with dat
CDT	always be on the student's	Must have all 4 parts of th	an evaluation schedule	prior year's information	Create a folder with lessc
Classroom test scores	always be on the student's	Must have all 4 parts of th	clearly defined behavior	prior year's information	Email subrequest with dat
CDT	should be on the student's	Must have all 4 parts of th	an evaluation schedule	prior year's information	Create slides for the lessc
CDT	always be on the student's	Must have 3 parts of the	number of times needed t	prior year's information	Create slides for the lessc
Classroom test scores	should be on the student's	Must have all 4 parts of th	clearly defined behavior	prior year's information	Create a folder with lessc
CDT	should be on the student's	Must have all 4 parts of th	clearly defined behavior	prior year's information	Email subrequest with dat
Classroom test scores	should be on the student's	Must have all 4 parts of th	clearly defined behavior	prior year's information	Email subrequest with dat
Classroom test scores	should be on the student's	Must have all 4 parts of th	an evaluation schedule	prior year's information	Email subrequest with dat
Classroom test scores	should be on the student's	Must have all 4 parts of th	an evaluation schedule	prior year's information	Create slides for the lessc
Classroom test scores	should be on the student's	Must have all 4 parts of th	clearly defined behavior	prior year's information	Email subrequest with dat
Classroom test scores	should be on the student's	Must have all 4 parts of th	clearly defined behavior	prior year's information	Create a folder with lessc
Classroom test scores	should be on the student's	Must have all 4 parts of th	clearly defined behavior	prior year's information	Email subrequest with dat
CDT	should be on the student's	Must have 3 parts of the	an evaluation schedule	prior year's information	Create slides for the lessc
PSSAs	should be on the student's	Must have all 4 parts of th	clearly defined behavior	prior year's information	Create slides for the lessc
Classroom test scores	should be on the student's	Must have all 4 parts of the	MAG criteria or it is inco	prior year's information	Create slides for the lessc
Classroom test scores	should be on the student's	Must have all 4 parts of th	an evaluation schedule	prior year's information	Email subrequest with dat
Classroom test scores	should be on the student's	Must have all 4 parts of th	an evaluation schedule	prior year's information	Email subrequest with dat
Classroom test scores	should be on the student's	Do not always need to be	clearly defined behavior	prior year's information	I prefer not to have a sub
Classroom test scores	should be on the student's	Must have all 4 parts of th	clearly defined behavior	prior year's information	Create a folder with lessc
Classroom test scores	should be on the student's	Must have all 4 parts of th	an evaluation schedule	prior year's information	Email subrequest with dat
Classroom test scores	should be on the student's	Must have all 4 parts of th	clearly defined behavior	prior year's information	Create a folder with lessc
Classroom test scores	should be on the student's	Must have all 4 parts of th	an evaluation schedule	prior year's information	Email subrequest with dat

What is one example of a formative assessment?	Academic goals have a standard, anchor, or element from the curriculum framework. This standard should:	Related service goals	Performance criteria does not include	When setting up your sub folder what is something you should not include?	For substitute coverage I have to do the following at least 48 hours in advance:
PSSAs	should be on the student's	Must have 3 parts of the	1 clearly defined behavior	prior year's information	Email subrequest with dat
Classroom test scores	should be on the student's	Must have all 4 parts of th	an evaluation schedule	prior year's information	Create a folder with less
Classroom test scores	should be on the student's	Must have all 4 parts of th	clearly defined behavior	prior year's information	Email subrequest with dat
Classroom test scores	should be on the student's	Must have all 4 parts of th	an evaluation schedule	prior year's information	Create a folder with less
Classroom test scores	should be on the student's	Must have all 4 parts of th	clearly defined behavior	prior year's information	Create slides for the less
CDT	should be on the student's	Must have all 4 parts of th	clearly defined behavior	prior year's information	Email subrequest with dat
CDT	should be on the student's	Must have all 4 parts of th	clearly defined behavior	prior year's information	Email subrequest with dat
Classroom test scores	should be on the student's	Must have all 4 parts of th	an evaluation schedule	prior year's information	I prefer not to have a sub
Classroom test scores	should be on the student's	Must have all 4 parts of th	an evaluation schedule	prior year's information	I prefer not to have a sub
Classroom test scores	should be on the student's	Must have all 4 parts of th	an evaluation schedule	prior year's information	Email subrequest with dat
Classroom test scores	always be on the student's	Must have 3 parts of the	1 clearly defined behavior	prior year's information	Email subrequest with dat
Classroom test scores	should be on the student's	Must have all 4 parts of th	clearly defined behavior	prior year's information	Create a folder with less
Classroom test scores	should be on the student's	Must have all 4 parts of th	an evaluation schedule	prior year's information	Email subrequest with dat
Classroom test scores	always be on the student's	Must have all 4 parts of th	number of times needed t	prior year's information	Create a folder with less
Classroom test scores	should be on the student's	Must have all 4 parts of th	clearly defined behavior	prior year's information	Create a folder with less
Classroom test scores	should be on the student's	Must have all 4 parts of th	clearly defined behavior	prior year's information	Email subrequest with dat
Classroom test scores	should be on the student's	Must have all 4 parts of th	an evaluation schedule	prior year's information	Create a folder with less
Classroom test scores	should be on the student's	Must have all 4 parts of th	an evaluation schedule	prior year's information	Email subrequest with dat
CDT	should be on the student's	Must have all 4 parts of the	MAG criteria or it is inco	prior year's information	Email subrequest with dat
CDT	should be on the student's	Must have all 4 parts of th	an evaluation schedule	prior year's information	Email subrequest with dat
CDT	always be on the student's	Must have all 4 parts of th	clearly defined behavior	prior year's information	Email subrequest with dat
Classroom test scores	always be on the student's	Must have all 4 parts of th	clearly defined behavior	login info for TV/K12	Email subrequest with dat
Classroom test scores	should be on the student's	Must have 3 parts of the	1 the level of mastery	prior year's information	Create a folder with less
Classroom test scores	always be on the student's	Must have all 4 parts of th	number of times needed t	prior year's information	Email subrequest with dat
Classroom test scores	always be on the student's	Must have all 4 parts of th	clearly defined behavior	prior year's information	Email subrequest with dat

**If a student needs special materials listed in his/her IEP such as print materials, enlargements, or access to a curriculum I should:**

**IEPs do not need to be held if:**

**A student should have a NEW baseline if:**

**A full team meeting is needed for a SAIP when:**

n plan info.	Submit the special educational	the IEP is compliant, the	€ All of the above are reason	it now always needs to be
n plan info.	Email my supervisor with	the IEP is compliant, the	€ All of the above are reason	it now always needs to be
es, times, and the name of the classes in which I nee	Submit the special educational	the IEP is compliant, the	€ All of the above are reason	it now always needs to be
es, times, and the name of the classes in which I nee	Submit the special educational	the IEP is compliant, the	€ All of the above are reason	it now always needs to be
es, times, and the name of the classes in which I nee	Submit the special educational	the IEP is compliant, the	€ All of the above are reason	it now always needs to be
n plan info.	Submit the special educational	the IEP is compliant, the	€ All of the above are reason	it now always needs to be
es, times, and the name of the classes in which I nee	Submit the special educational	the IEP is compliant, the	€ All of the above are reason	it now always needs to be
n plan info.	Submit the special educational	the parent doesn't prefer	€ All of the above are reason	it now always needs to be
on that include answers to the problems	Submit the special educational	the IEP is compliant, the	€ All of the above are reason	it now always needs to be
n plan info.	Submit the special educational	the IEP is compliant, the	€ All of the above are reason	it now always needs to be
n plan info.	Submit the special educational	the IEP is compliant, the	€ The student is not making it	now always needs to be
es, times, and the name of the classes in which I nee	Submit the special educational	the IEP is compliant, the	€ All of the above are reason	only when it's the third me
n plan info.	Submit the special educational	the IEP is compliant, the	€ All of the above are reason	it now always needs to be
es, times, and the name of the classes in which I nee	Submit the special educational	the IEP is compliant, the	€ The data is more than 6 m	it now always needs to be
on that include answers to the problems	Submit the special educational	the IEP is compliant, the	€ All of the above are reason	it now always needs to be
on that include answers to the problems	Email my supervisor with	the IEP is compliant, the	€ The data is more than 6 m	it now always needs to be
es, times, and the name of the classes in which I nee	Submit the special educational	the IEP is compliant, the	€ All of the above are reason	it now always needs to be
on that include answers to the problems	Submit the special educational	the IEP is compliant, the	€ All of the above are reason	it now always needs to be
n plan info.	Submit the special educational	the IEP is compliant, the	€ The data is more than 6 m	it now always needs to be
es, times, and the name of the classes in which I nee	Submit the special educational	the IEP is compliant, the	€ The data is more than 6 m	it now always needs to be
es, times, and the name of the classes in which I nee	Submit the special educational	the IEP is compliant, the	€ The data is more than 6 m	it now always needs to be
es, times, and the name of the classes in which I nee	Email my supervisor with	the IEP is compliant, the	€ All of the above are reason	it now always needs to be
n plan info.	Submit the special educational	the IEP is compliant, the	€ All of the above are reason	it now always needs to be
es, times, and the name of the classes in which I nee	Submit the special educational	the IEP is compliant, the	€ All of the above are reason	it now always needs to be
n plan info.	Submit the special educational	the IEP is compliant, the	€ The data is more than 6 m	it now always needs to be
on that include answers to the problems	Submit the special educational	the IEP is compliant, the	€ All of the above are reason	it now always needs to be

**If a student needs special materials listed in his/her IEP such as print materials, enlargements, or access to a curriculum I should:**

**IEPs do not need to be held if:**

**A student should have a NEW baseline if:**

**A full team meeting is needed for a SAIP when:**

on that include answers to the problems	Submit the special educational	the IEP is compliant, the	€ All of the above are reason	it now always needs to be
on that include answers to the problems	Submit the special educational	the IEP is compliant, the	€ All of the above are reason	it now always needs to be
es, times, and the name of the classes in which I need	Submit the special educational	the IEP is compliant, the	€ All of the above are reason	it now always needs to be
n plan info.	Email my supervisor with	the IEP is compliant, the	€ All of the above are reason	it now always needs to be
es, times, and the name of the classes in which I need	Submit the special educational	the IEP is compliant, the	€ All of the above are reason	it now always needs to be
on that include answers to the problems	Submit the special educational	the IEP is compliant, the	€ All of the above are reason	it now always needs to be
on that include answers to the problems	Submit the special educational	the IEP is compliant, the	€ All of the above are reason	it now always needs to be
es, times, and the name of the classes in which I need	Submit the special educational	the IEP is compliant, the	€ All of the above are reason	it now always needs to be
es, times, and the name of the classes in which I need	Submit the special educational	the IEP is compliant, the	€ All of the above are reason	it now always needs to be
on that include answers to the problems	Submit the special educational	the IEP is compliant, the	€ The data is more than 6 m	n it now always needs to be
on that include answers to the problems	Submit the special educational	the IEP is compliant, the	€ The data is more than 6 m	n it now always needs to be
es, times, and the name of the classes in which I need	Submit the special educational	the IEP is compliant, the	€ All of the above are reason	it now always needs to be
es, times, and the name of the classes in which I need	Submit the special educational	the parent doesn't prefer	€ All of the above are reason	only when it's the third me
es, times, and the name of the classes in which I need	Email my supervisor with	the IEP is compliant, the	€ The data is more than 6 m	n it now always needs to be
on that include answers to the problems	Submit the special educational	the IEP is compliant, the	€ All of the above are reason	it now always needs to be
n plan info.	Submit the special educational	the IEP is compliant, the	€ The data is more than 6 m	n it now always needs to be
n plan info.	Submit the special educational	the IEP is compliant, the	€ All of the above are reason	it now always needs to be
n plan info.	Submit the special educational	the IEP is compliant, the	€ The data is more than 6 m	n it now always needs to be
n plan info.	Submit the special educational	the IEP is compliant, the	€ The data is more than 6 m	n it now always needs to be
on that include answers to the problems	Submit the special educational	it's an RR since those onl	The data is more than 6 m	n it now always needs to be
es, times, and the name of the classes in which I need	Submit the special educational	the parent doesn't prefer	€ All of the above are reason	only when it's the third me
on that include answers to the problems	Submit the special educational	the IEP is compliant, the	€ All of the above are reason	it now always needs to be
es, times, and the name of the classes in which I need	Submit the special educational	the IEP is compliant, the	€ All of the above are reason	it now always needs to be
on that include answers to the problems	Submit the special educational	the IEP is compliant, the	€ All of the above are reason	it now always needs to be
n plan info.	Submit the special educational	the IEP is compliant, the	€ The data is more than 6 m	n it now always needs to be
n plan info.	Submit the special educational	the IEP is compliant, the	€ All of the above are reason	it now always needs to be

**If a student needs special materials listed in his/her IEP such as print materials, enlargements, or access to a curriculum I should:**

**IEPs do not need to be held if:**

**A student should have a NEW baseline if:**

**A full team meeting is needed for a SAIP when:**

es, times, and the name of the classes in which I need	Submit the special educational materials	the IEP is compliant, the data is more than 6 months old	All of the above are reasons it now always needs to be held
on that include answers to the problems	Submit the special educational materials	the IEP is compliant, the data is more than 6 months old	it now always needs to be held
on that include answers to the problems	Submit the special educational materials	the IEP is compliant, the data is more than 6 months old	it now always needs to be held
es, times, and the name of the classes in which I need	Submit the special educational materials	the parent doesn't prefer the IEP is compliant, the data is more than 6 months old	it now always needs to be held
n plan info.	Email my supervisor with the IEP is compliant, the data is more than 6 months old	the IEP is compliant, the data is more than 6 months old	only when it's the second meeting
es, times, and the name of the classes in which I need	Submit the special educational materials	the IEP is compliant, the data is more than 6 months old	it now always needs to be held
on that include answers to the problems	Email my supervisor with the IEP is compliant, the data is more than 6 months old	the IEP is compliant, the data is more than 6 months old	it now always needs to be held
on that include answers to the problems	Submit the special educational materials	it's an RR since those only the IEP is compliant, the data is more than 6 months old	it now always needs to be held
n plan info.	Submit the special educational materials	the IEP is compliant, the data is more than 6 months old	only when it's the third meeting
es, times, and the name of the classes in which I need	Email my supervisor with the IEP is compliant, the data is more than 6 months old	the IEP is compliant, the data is more than 6 months old	it now always needs to be held
es, times, and the name of the classes in which I need	Submit the special educational materials	the IEP is compliant, the data is more than 6 months old	it now always needs to be held
es, times, and the name of the classes in which I need	Submit the special educational materials	the IEP is compliant, the data is more than 6 months old	only when it's the third meeting
on that include answers to the problems	Submit the special educational materials	the IEP is compliant, the data is more than 6 months old	it now always needs to be held
es, times, and the name of the classes in which I need	Submit the special educational materials	the IEP is compliant, the data is more than 6 months old	it now always needs to be held
n plan info.	Submit the special educational materials	the IEP is compliant, the data is more than 6 months old	it now always needs to be held
es, times, and the name of the classes in which I need	Submit the special educational materials	the IEP is compliant, the data is more than 6 months old	it now always needs to be held
on that include answers to the problems	Submit the special educational materials	the IEP is compliant, the data is more than 6 months old	it now always needs to be held
on that include answers to the problems	Submit the special educational materials	the IEP is compliant, the data is more than 6 months old	it now always needs to be held
on that include answers to the problems	Submit the special educational materials	the IEP is compliant, the data is more than 6 months old	it now always needs to be held
es, times, and the name of the classes in which I need	Submit the special educational materials	the IEP is compliant, the data is more than 6 months old	it now always needs to be held
es, times, and the name of the classes in which I need	Submit the special educational materials	the IEP is compliant, the data is more than 6 months old	it now always needs to be held
so I just need to let my supervisor know I'm pushing	Submit the special educational materials	the IEP is compliant, the data is more than 6 months old	only when it's the third meeting
n plan info.	Submit the special educational materials	the IEP is compliant, the data is more than 6 months old	it now always needs to be held
es, times, and the name of the classes in which I need	Submit the special educational materials	the IEP is compliant, the data is more than 6 months old	it now always needs to be held
n plan info.	Submit the special educational materials	the IEP is compliant, the data is more than 6 months old	it now always needs to be held
es, times, and the name of the classes in which I need	Submit the special educational materials	the IEP is compliant, the data is more than 6 months old	only when it's the second meeting
es, times, and the name of the classes in which I need	Submit the special educational materials	the IEP is compliant, the data is more than 6 months old	it now always needs to be held



**If a student needs special materials listed in his/her IEP such as print materials, enlargements, or access to a curriculum I should:**

**IEPs do not need to be held if:**

**A student should have a NEW baseline if:**

**A full team meeting is needed for a SAIP when:**

es, times, and the name of the classes in which I need to submit the special education plan info.	Submit the special education plan info.	the IEP is compliant, the data is more than 6 months old.	All of the above are reasonable.	it now always needs to be held.
es, times, and the name of the classes in which I need to submit the special education plan info.	Submit the special education plan info.	the IEP is compliant, the data is more than 6 months old.	All of the above are reasonable.	it now always needs to be held.
on that include answers to the problems	Submit the special education plan info.	the IEP is compliant, the data is more than 6 months old.	All of the above are reasonable.	only when it's the second meeting.
es, times, and the name of the classes in which I need to submit the special education plan info.	Submit the special education plan info.	the IEP is compliant, the data is more than 6 months old.	The data is more than 6 months old.	only when it's the third meeting.
so I just need to let my supervisor know I'm pushing for it	Email my supervisor with the IEP.	the IEP is compliant, the data is more than 6 months old.	The data is more than 6 months old.	it now always needs to be held.
so I just need to let my supervisor know I'm pushing for it	Submit the special education plan info.	it's an RR since those only need to be held once a year.	All of the above are reasonable.	it now always needs to be held.
es, times, and the name of the classes in which I need to submit the special education plan info.	Submit the special education plan info.	the IEP is compliant, the data is more than 6 months old.	All of the above are reasonable.	it now always needs to be held.
es, times, and the name of the classes in which I need to submit the special education plan info.	Submit the special education plan info.	the IEP is compliant, the data is more than 6 months old.	All of the above are reasonable.	only when it's the third meeting.
es, times, and the name of the classes in which I need to submit the special education plan info.	Submit the special education plan info.	the IEP is compliant, the data is more than 6 months old.	The data is more than 6 months old.	it now always needs to be held.
es, times, and the name of the classes in which I need to submit the special education plan info.	Submit the special education plan info.	it's an RR since those only need to be held once a year.	All of the above are reasonable.	it now always needs to be held.
es, times, and the name of the classes in which I need to submit the special education plan info.	Submit the special education plan info.	the IEP is compliant, the data is more than 6 months old.	All of the above are reasonable.	only when it's the third meeting.
es, times, and the name of the classes in which I need to submit the special education plan info.	Submit the special education plan info.	the IEP is compliant, the data is more than 6 months old.	All of the above are reasonable.	it now always needs to be held.
es, times, and the name of the classes in which I need to submit the special education plan info.	Submit the special education plan info.	the IEP is compliant, the data is more than 6 months old.	All of the above are reasonable.	only when it's the third meeting.
es, times, and the name of the classes in which I need to submit the special education plan info.	Submit the special education plan info.	the IEP is compliant, the data is more than 6 months old.	All of the above are reasonable.	it now always needs to be held.
es, times, and the name of the classes in which I need to submit the special education plan info.	Submit the special education plan info.	the parent doesn't prefer the IEP.	All of the above are reasonable.	it now always needs to be held.
es, times, and the name of the classes in which I need to submit the special education plan info.	Submit the special education plan info.	a parent asks for a meeting.	All of the above are reasonable.	it now always needs to be held.
es, times, and the name of the classes in which I need to submit the special education plan info.	Submit the special education plan info.	the IEP is compliant, the data is more than 6 months old.	All of the above are reasonable.	it now always needs to be held.
es, times, and the name of the classes in which I need to submit the special education plan info.	Submit the special education plan info.	the IEP is compliant, the data is more than 6 months old.	All of the above are reasonable.	when a parent isn't in agreement.
es, times, and the name of the classes in which I need to submit the special education plan info.	Submit the special education plan info.	the IEP is compliant, the data is more than 6 months old.	All of the above are reasonable.	it now always needs to be held.



<b>Why do I need to complete a related services webform after a SAIP meeting?</b>	<b>Do I need to request ASYNC attendance mode if the student has a doctor's note requesting this?</b>	<b>Where is the best place to obtain therapist contact information?</b>	<b>Where should I document contact with related service providers?</b>	<b>How often should I keep in contact with my student's related service provider?</b>	<b>What norms should be used this year for goal setting?</b>
If the student isn't attending	Maybe. The team has to	Easy Trac	Easy Trac	At least as often as the IE	Winter
If the student isn't attending	Yes, because it's a doctor	Easy Trac	Easy Trac	At least as often as the IE	Winter
The student is being exited	Maybe. The team has to	Easy Trac	Tyler	Weekly	Fall
If the student isn't attending	Maybe. The team has to	Easy Trac	Easy Trac	At least as often as the IE	Winter
If the student isn't attending	Maybe. The team has to	Easy Trac	Easy Trac	Weekly	Winter
If the student isn't attending	Maybe. The team has to	Easy Trac	Easy Trac	At least as often as the IE	Winter
If the student isn't attending	Maybe. The team has to	Easy Trac	Easy Trac	At least as often as the IE	Winter
If the student isn't attending	Maybe. The team has to	Easy Trac	Tyler	Weekly	Fall
If the student isn't attending	Maybe. The team has to	Easy Trac	Easy Trac	Quarterly	Winter
If the student isn't attending	Maybe. The team has to	Easy Trac	Easy Trac	At least as often as the IE	Winter
If the student isn't attending	Maybe. The team has to	Easy Trac	Easy Trac	At least as often as the IE	Winter
I do not need to complete	Maybe. The team has to	Easy Trac	Easy Trac	Quarterly	Winter
If the student isn't attending	Maybe. The team has to	Easy Trac	Easy Trac	At least as often as the IE	Fall
If the student isn't attending	Maybe. The team has to	Easy Trac	Easy Trac	Quarterly	Winter
If the student isn't attending	Maybe. The team has to	Easy Trac	Easy Trac	At least as often as the IE	Winter
If the student isn't attending	Maybe. The team has to	Easy Trac	Easy Trac	Weekly	Winter
The student is being exited	Maybe. The team has to	Easy Trac	Tyler	At least as often as the IE	Fall
If the student isn't attending	Maybe. The team has to	Easy Trac	Easy Trac	At least as often as the IE	Winter
If the student isn't attending	Maybe. The team has to	Easy Trac	Tyler	At least as often as the IE	Winter
If the student isn't attending	Maybe. The team has to	Easy Trac	Tyler	At least as often as the IE	Winter
If the student isn't attending	Maybe. The team has to	Easy Trac	Easy Trac	At least as often as the IE	Fall
If the student isn't attending	Maybe. The team has to	Easy Trac	Tyler	At least as often as the IE	Winter
If the student isn't attending	Maybe. The team has to	Easy Trac	Easy Trac	At least as often as the IE	Winter
If the student isn't attending	Maybe. The team has to	Easy Trac	Easy Trac	Weekly	Winter
If the student isn't attending	Maybe. The team has to	Easy Trac	Tyler	At least as often as the IE	Winter
If the student isn't attending	Maybe. The team has to	Easy Trac	Easy Trac	At least as often as the IE	Winter

Why do I need to complete a related services webform after a SAIP meeting?	Do I need to request ASYNC attendance mode if the student has a doctor's note requesting this?	Where is the best place to obtain therapist contact information?	Where should I document contact with related service providers?	How often should I keep in contact with my student's related service provider?	What norms should be used this year for goal setting?
If the student isn't attending	Maybe. The team has to	Easy Trac	Easy Trac	At least as often as the IE	Winter
If the student isn't attending	Maybe. The team has to	Easy Trac	Easy Trac	At least as often as the IE	Winter
If the student isn't attending	No, Agora doesn't follow a	Easy Trac	Easy Trac	At least as often as the IE	Winter
If the student isn't attending	No, Agora doesn't follow a	Easy Trac	Easy Trac	At least as often as the IE	Winter
I do not need to complete	Maybe. The team has to	Easy Trac	Easy Trac	At least as often as the IE	Winter
If the student isn't attending	Maybe. The team has to	Easy Trac	Tyler	Quarterly	Winter
If the student isn't attending	Maybe. The team has to	Easy Trac	Easy Trac	At least as often as the IE	Fall
If the student isn't attending	Maybe. The team has to	Easy Trac	My personal notes	At least as often as the IE	Winter
If the student isn't attending	Maybe. The team has to	Easy Trac	Easy Trac	At least as often as the IE	Winter
If the student isn't attending	Maybe. The team has to	Easy Trac	Easy Trac	At least as often as the IE	Winter
If the student isn't attending	Maybe. The team has to	Easy Trac	Easy Trac	At least as often as the IE	Winter
If the student isn't attending	Maybe. The team has to	Easy Trac	Easy Trac	At least as often as the IE	Winter
If the student isn't attending	Maybe. The team has to	Easy Trac	Tyler	At least as often as the IE	Winter
If the student isn't attending	Maybe. The team has to	Easy Trac	Easy Trac	At least as often as the IE	Winter
If the student isn't attending	Maybe. The team has to	Easy Trac	Easy Trac	At least as often as the IE	Winter
If the student isn't attending	Maybe. The team has to	Easy Trac	Easy Trac	At least as often as the IE	Winter
If the student isn't attending	Maybe. The team has to	Easy Trac	Easy Trac	At least as often as the IE	Winter
If the student isn't attending	Maybe. The team has to	Easy Trac	Easy Trac	At least as often as the IE	Winter
If the student isn't attending	Maybe. The team has to	Easy Trac	Easy Trac	At least as often as the IE	Winter
If the student isn't attending	Maybe. The team has to	Easy Trac	Easy Trac	At least as often as the IE	Winter
If the student isn't attending	Maybe. The team has to	Easy Trac	Easy Trac	At least as often as the IE	Winter
If the student isn't attending	Maybe. The team has to	Easy Trac	Easy Trac	At least as often as the IE	Winter
If the student isn't attending	Maybe. The team has to	Easy Trac	Easy Trac	At least as often as the IE	Winter
If the student isn't attending	Maybe. The team has to	Easy Trac	Easy Trac	At least as often as the IE	Winter
If the student isn't attending	Yes, because it's a doctor	Easy Trac	Easy Trac	Quarterly	Winter
If the student isn't attending	Maybe. The team has to	Easy Trac	Easy Trac	Quarterly	Winter
If the student isn't attending	Maybe. The team has to	Easy Trac	Easy Trac	At least as often as the IE	Winter

<b>Why do I need to complete a related services webform after a SAIP meeting?</b>	<b>Do I need to request ASYNC attendance mode if the student has a doctor's note requesting this?</b>	<b>Where is the best place to obtain therapist contact information?</b>	<b>Where should I document contact with related service providers?</b>	<b>How often should I keep in contact with my student's related service provider?</b>	<b>What norms should be used this year for goal setting?</b>
If the student isn't attending	Maybe. The team has to	Easy Trac	Easy Trac	At least as often as the IE	Winter
If the student isn't attending	Maybe. The team has to	Easy Trac	Tyler	At least as often as the IE	Winter
If the student isn't attending	Maybe. The team has to	Easy Trac	Easy Trac	At least as often as the IE	Winter
If the student isn't attending	Maybe. The team has to	Easy Trac	Easy Trac	At least as often as the IE	Winter
If the student isn't attending	Maybe. The team has to	Easy Trac	Easy Trac	At least as often as the IE	Winter
If the student isn't attending	Maybe. The team has to	Easy Trac	Tyler	At least as often as the IE	Winter
If the student isn't attending	Maybe. The team has to	Easy Trac	Tyler	At least as often as the IE	Winter
If the student isn't attending	Maybe. The team has to	Smartsheet	Easy Trac	Quarterly	Winter
If the student isn't attending	Maybe. The team has to	Easy Trac	Easy Trac	At least as often as the IE	Winter
If the student isn't attending	Maybe. The team has to	Easy Trac		At least as often as the IE	Winter
If the student isn't attending	Maybe. The team has to	Easy Trac	Tyler	Quarterly	Winter
If the student isn't attending	Maybe. The team has to	Easy Trac	Email only	At least as often as the IE	Fall
If the student isn't attending	Maybe. The team has to	Easy Trac	Easy Trac	Quarterly	Spring
The student is being exited	Maybe. The team has to	Easy Trac	Tyler	At least as often as the IE	Winter
If the student isn't attending	Maybe. The team has to	Easy Trac	Tyler	At least as often as the IE	Winter
If the student isn't attending	Maybe. The team has to	Easy Trac	Easy Trac	At least as often as the IE	Winter
If the student isn't attending	Maybe. The team has to	Easy Trac	Tyler	At least as often as the IE	Fall
If the student isn't attending	Maybe. The team has to	Easy Trac	Easy Trac	At least as often as the IE	Winter
If the student isn't attending	Maybe. The team has to	Easy Trac	Easy Trac	Weekly	Winter
I do not need to complete	Maybe. The team has to	Easy Trac	My personal notes	At least as often as the IE	Winter
If the student isn't attending	Yes, because it's a doctor	Easy Trac	Tyler	At least as often as the IE	Spring
If the student isn't attending	Maybe. The team has to	Easy Trac	Easy Trac	At least as often as the IE	Winter
If the student isn't attending	Maybe. The team has to	Easy Trac	Easy Trac	Quarterly	Spring
I do not need to complete	Yes, because it's a doctor	Tyler	Tyler	At least as often as the IE	Fall
If the student isn't attending	Maybe. The team has to	Easy Trac	Easy Trac	At least as often as the IE	Winter



**Why can't you use the goal set slider in AimswebPlus when goal setting for the Classic Measures?**

**All students should be baselined up to the:**

- below average range There are no Student Growth Percentiles loaded.
- well below average range There are no Student Growth Percentiles loaded.
- average range The norms are only based on the LEA norms and not the National norms.
- well below average range There are no Student Growth Percentiles loaded.
- well below average range There are no Student Growth Percentiles loaded.
- frustration level range There are no Student Growth Percentiles loaded.
- frustration level range There are no Student Growth Percentiles loaded.
- frustration level range There are no Student Growth Percentiles loaded.
- well below average range There are no Student Growth Percentiles loaded.
- well below average range There are no Student Growth Percentiles loaded.
- well below average range There are no Student Growth Percentiles loaded.
- frustration level range There are no Student Growth Percentiles loaded.
- well below average range There are no Student Growth Percentiles loaded.
- well below average range There are no Student Growth Percentiles loaded.
- well below average range There are no Student Growth Percentiles loaded.
- well below average range
- average range The norms are only based on the LEA norms and not the National norms.
- well below average range There are no Student Growth Percentiles loaded.
- well below average range There are no Student Growth Percentiles loaded.
- well below average range There are no Student Growth Percentiles loaded.
- frustration level range There are no Student Growth Percentiles loaded.
- well below average range There are no Student Growth Percentiles loaded.
- well below average range You should always use the goal set slider.
- well below average range There are no Student Growth Percentiles loaded.
- well below average range There are no Student Growth Percentiles loaded.
- well below average range There are no Student Growth Percentiles loaded.

**Why can't you use the goal set slider in AimswebPlus when goal setting for the Classic Measures?**

**All students should be baselined up to the:**

- well below average range There are no Student Growth Percentiles loaded.
- well below average range There are no Student Growth Percentiles loaded.
- well below average range There are no Student Growth Percentiles loaded.
- well below average range There are no Student Growth Percentiles loaded.
- frustration level range You should always use the goal set slider.
- well below average range You should always use the goal set slider.
- frustration level range There are no Student Growth Percentiles loaded.
- well below average range There are no Student Growth Percentiles loaded.
- well below average range There are no Student Growth Percentiles loaded.
- well below average range There are no Student Growth Percentiles loaded.
- well below average range There are no Student Growth Percentiles loaded.
- well below average range There are no Student Growth Percentiles loaded.
- below average range There are no Student Growth Percentiles loaded.
- well below average range There are no Student Growth Percentiles loaded.
- well below average range There are no Student Growth Percentiles loaded.
- well below average range There are no Student Growth Percentiles loaded.
- well below average range There are no Student Growth Percentiles loaded.
- frustration level range There are no Student Growth Percentiles loaded.
- well below average range There are no Student Growth Percentiles loaded.
- well below average range There are no Student Growth Percentiles loaded.
- well below average range There are no Student Growth Percentiles loaded.
- frustration level range The norms are only based on the LEA norms and not the National norms.
- well below average range There are no Student Growth Percentiles loaded.
- well below average range There are no Student Growth Percentiles loaded.
- well below average range There are no Student Growth Percentiles loaded.
- average range There are no Student Growth Percentiles loaded.



**Why can't you use the goal set slider in AimswebPlus when goal setting for the Classic Measures?**

**All students should be baselined up to the:**

- well below average range The norms are only based on the LEA norms and not the National norms.
- well below average range There are no Student Growth Percentiles loaded.
- well below average range There are no Student Growth Percentiles loaded.
- well below average range There are no Student Growth Percentiles loaded.
- well below average range The norms are only based on the LEA norms and not the National norms.
- well below average range There are no Student Growth Percentiles loaded.
- well below average range There are no Student Growth Percentiles loaded.
- well below average range You should always use the goal set slider.
- frustration level range There are no Student Growth Percentiles loaded.
- well below average range There are no Student Growth Percentiles loaded.
- well below average range There are no Student Growth Percentiles loaded.
- well below average range The norms are only based on the LEA norms and not the National norms.
- below average range There are no Student Growth Percentiles loaded.
- well below average range There are no Student Growth Percentiles loaded.
- well below average range There are no Student Growth Percentiles loaded.
- well below average range There are no Student Growth Percentiles loaded.
- average range There are no Student Growth Percentiles loaded.
- frustration level range There are no Student Growth Percentiles loaded.
- frustration level range You should always use the goal set slider.
- below average range There are no Student Growth Percentiles loaded.
- frustration level range There are no Student Growth Percentiles loaded.
- well below average range There are no Student Growth Percentiles loaded.
- frustration level range The norms are only based on the LEA norms and not the National norms.
- average range The norms are only based on the LEA norms and not the National norms.
- well below average range There are no Student Growth Percentiles loaded.

# Agenda

- Introduction to MobyMax
- Placement Tests & How to Assign
- Modules for ELA & Math
- Progress Monitoring & Progress Reports
- Goals
- Monitoring Student Progress
- Q&A

Session Name	Moby Max Progress Monitoring
Session Type	Small Group
Instructional Level	General
Session Owner	Lapsker, Kristina
Teacher	Lapsker, Kristina
Subject	Other
Unit / Lesson	
Program(s)	None
Date and Time	Fri 06/11/2021, 01:00pm-02:00pm (EDT)
Number of Required and Optional Participants	100%
Participation Rate of Required and Optional Participants	100%
Number of Required Participants	100%
Participation Rate of Required Participants	100%
Number of Guests	3600%
Course Codes	
Course Names	

Elementary Special Education  
Team Meeting: Act 13 & CR's  
1/13/22



## Act 13 & Constructive Response



Act 13 for all Push-in and K-2 MC teachers will use Benchmark Completion data

MC Teachers in 3-5 will continue with CR's

For Act 13, there will NOT be benchmark data or Q3. You will need to go back and enter scores for Q1 (that would be the Fall benchmark)

This data will become part of your metrics in your EOY evaluation.

1. Summary						
Attended participants	14					
Start time	1/13/22, 12:23:00 PM					
End time	1/13/22, 12:52:13 PM					
Meeting duration	29m 13s					
Average attendance time	23m 19s					
2. Participants						
Name	First join	Last leave	In-meeting duration	Email	Participant ID (UPN)	Role
Jennifer Buss	1/13/22, 12:23:15 PM	1/13/22, 12:52:10 PM	28m 54s	jbuss@agora.org	jbuss@agora.org	Presenter
Carmen Riggle	1/13/22, 12:23:29 PM	1/13/22, 12:52:07 PM	28m 38s	criggle@agora.org	criggle@agora.org	Presenter
Regina Mallon	1/13/22, 12:23:46 PM	1/13/22, 12:52:03 PM	28m 17s	gmallon@agora.org	gmallon@agora.org	Presenter
Laurie Super	1/13/22, 12:26:29 PM	1/13/22, 12:51:59 PM	25m 30s	lsuper@agora.org	lsuper@agora.org	Presenter
Casey Chaffin	1/13/22, 12:27:41 PM	1/13/22, 12:52:05 PM	24m 23s	cchaffin@agora.org	cchaffin@agora.org	Presenter
Amanda Gruszewski	1/13/22, 12:28:09 PM	1/13/22, 12:52:06 PM	23m 56s	agruszewski@agora.org	agruszewski@agora.org	Presenter
Stephanie Mannarino	1/13/22, 12:28:25 PM	1/13/22, 12:52:02 PM	23m 37s	smannarino@agora.org	smannarino@agora.org	Presenter
Janet Ulewicz	1/13/22, 12:30:05 PM	1/13/22, 12:52:02 PM	21m 57s	julewicz@agora.org	julewicz@agora.org	Presenter
Brittney Walczak	1/13/22, 12:30:19 PM	1/13/22, 12:52:02 PM	21m 42s	bwalczak@agora.org	bwalczak@agora.org	Presenter
Caleb Cragle	1/13/22, 12:30:51 PM	1/13/22, 12:52:01 PM	21m 9s	ccragle@agora.org	ccragle@agora.org	Presenter
Melissa Franklin	1/13/22, 12:31:49 PM	1/13/22, 12:52:05 PM	20m 15s	mfranklin@agora.org	mfranklin@agora.org	Presenter
Michelle Cukauskas	1/13/22, 12:32:12 PM	1/13/22, 12:52:08 PM	19m 56s	mcukauskas@agora.org	mcukauskas@agora.org	Organizer
Stefanie Marcello	1/13/22, 12:32:43 PM	1/13/22, 12:52:13 PM	19m 29s	smarcello@agora.org	smarcello@agora.org	Presenter
Cathrine Hartman	1/13/22, 12:33:17 PM	1/13/22, 12:52:02 PM	18m 45s	chartman@agora.org	chartman@agora.org	Presenter
3. In-Meeting activities						
Name	Join time	Leave time	Duration	Email	Role	
Jennifer Buss	1/13/22, 12:23:15 PM	1/13/22, 12:52:10 PM	28m 54s	jbuss@agora.org	Presenter	
Carmen Riggle	1/13/22, 12:23:29 PM	1/13/22, 12:52:07 PM	28m 38s	criggle@agora.org	Presenter	
Regina Mallon	1/13/22, 12:23:46 PM	1/13/22, 12:52:03 PM	28m 17s	gmallon@agora.org	Presenter	
Laurie Super	1/13/22, 12:26:29 PM	1/13/22, 12:51:59 PM	25m 30s	lsuper@agora.org	Presenter	
Casey Chaffin	1/13/22, 12:27:41 PM	1/13/22, 12:52:05 PM	24m 23s	cchaffin@agora.org	Presenter	
Amanda Gruszewski	1/13/22, 12:28:09 PM	1/13/22, 12:52:06 PM	23m 56s	agruszewski@agora.org	Presenter	
Stephanie Mannarino	1/13/22, 12:28:25 PM	1/13/22, 12:52:02 PM	23m 37s	smannarino@agora.org	Presenter	
Janet Ulewicz	1/13/22, 12:30:05 PM	1/13/22, 12:52:02 PM	21m 57s	julewicz@agora.org	Presenter	
Brittney Walczak	1/13/22, 12:30:19 PM	1/13/22, 12:52:02 PM	21m 42s	bwalczak@agora.org	Presenter	
Caleb Cragle	1/13/22, 12:30:51 PM	1/13/22, 12:52:01 PM	21m 9s	ccragle@agora.org	Presenter	

Melissa Franklin	1/13/22, 12:31:49 PM	1/13/22, 12:52:05 PM	20m 15s	mfranklin@agora.org	Presenter	
Michelle Cukauskas	1/13/22, 12:32:12 PM	1/13/22, 12:52:08 PM	19m 56s	mcukauskas@agora.org	Organizer	



# Answers to your Questions

Special Education Team  
Mtg 9/3/21





*HAPPY BIRTHDAY ERIN*



# School-Wide PD Days

- Sept 29      March 16
- Oct 22      March 25
- Nov 4      June 6
- Nov 11      June 7
- Dec 15      June 8
- Jan 3      June 9
- Jan 20      June 10
- Feb 10

\*\*The calendar was uploaded to our Elementary Folder in the Google Drive

## 2021-2022 AGORA CYBER CHARTER SCHOOL ACADEMIC CALENDAR

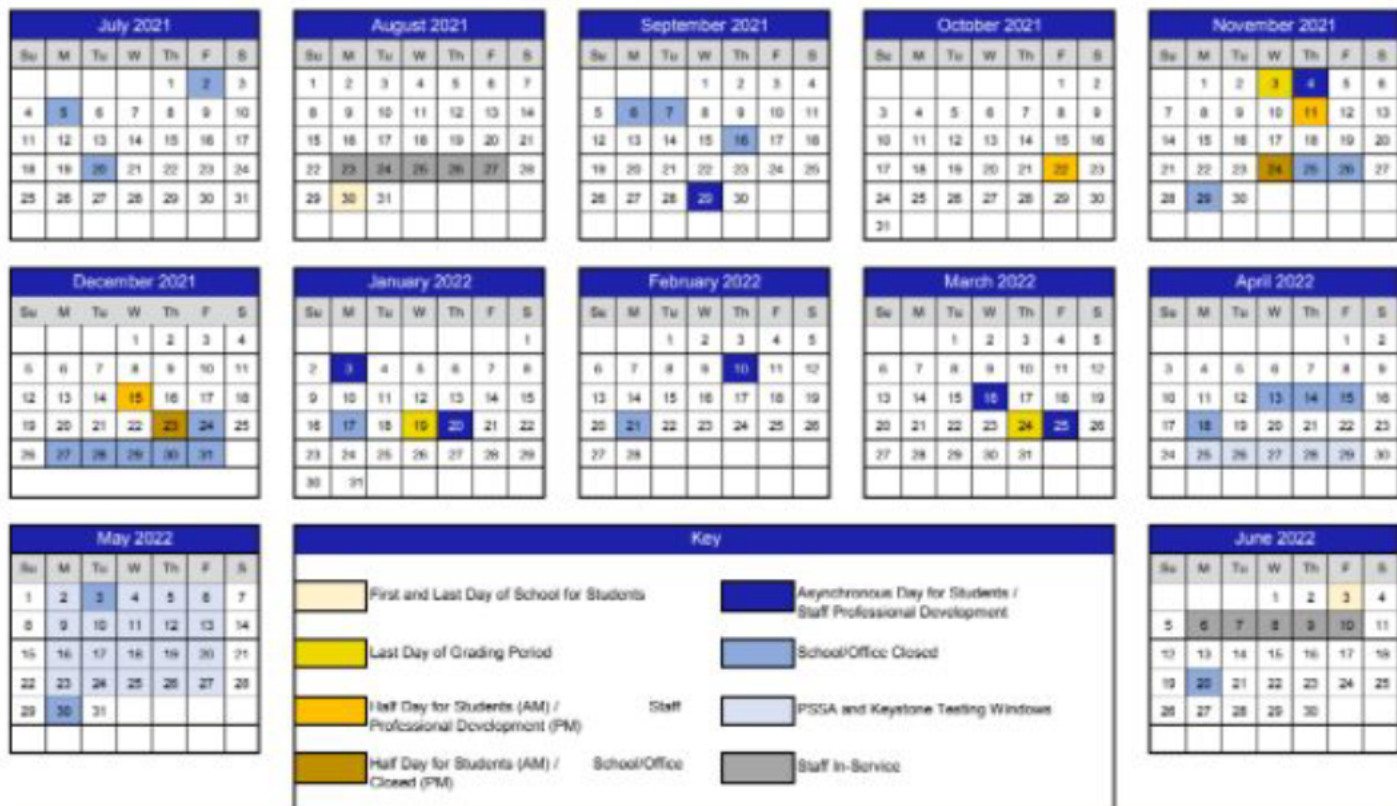

# SHOUT IT OUT Form

<https://forms.gle/vxwtzSU2xYab1GFV6>



- We want you to celebrate YOURSELF and EACH OTHER by SHOUTING IT OUT!!

- You can fill out this form, one per celebration.

- If someone did something awesome, tell me about it.

- If YOU did something awesome, tell me about it!

- The information will be added to the individuals PAETEP notes.

With our new email system, do we still need to password protect when sending documents to parents?



Nope! You do not have to password protect anything that you send to parents anymore.

- 
- Lesson plans should be completed for your small group session.
  - There should be a shell in Atlas for you to upload your lessons.



# Atlas

Political Map of the World, October 2010

**LEGEND**  
■ Independent state  
■ Dependence or area of special sovereignty  
■ Island / island group  
● Capital  
■ Landlocked  
■ International territory



- Atlas is our road map for the Curriculum
- This is where our content and lesson plans will be housed.
- General Ed Curriculum/lessons are already uploaded in there.
- For RC, we have created a duplicate of Gen Ed and you can adjust and modify to fit your students needs.
- Michelle and the Curriculum Team can meet with you if you have questions about this.

# Schedule for Students

---

- The classes are longer, but they allow for direct instruction and then small group, intervention, etc
- Focus Time and Learning Lab allow for Pull Out time based on students needs.
- Students can notify teachers when they need a break in Newrow and take a break anytime in class.
- You will be able to push in and support or offer suggestions







# Reading

Content Code	Eligible Content	Grades					
		K	1	2	3	4	5
<b>Key Ideas and Details:</b>							
<b>Literature Text</b>							
<a href="#">CC.1.3.K.B</a>	Answer questions about key details in a text.	•					
<a href="#">CC.1.3.1.B</a>	Ask and answer questions about key details in a text.		•				
<a href="#">CC.1.3.2.B</a>	Ask and answer questions such as who, what, where, when, why, and how to demonstrate understanding of key details in a text.			•			
<a href="#">EO3.A-K.1.1.1</a>	Ask and answer questions to demonstrate understanding of a text, referring explicitly to the text as the basis for the answers.						
<a href="#">EO4.A-K.1.1.1</a>	Refer to details and examples in a text when explaining what the text says explicitly and when drawing inferences from the text.						
<a href="#">EO5.A-K.1.1.1</a>	Quote accurately from a text when explaining what the text says explicitly and when drawing inferences and/or making generalizations from the text.						
<a href="#">EO6.A-K.1.1.1</a>	Cite textual evidence to support analysis of what the text says explicitly as well as inferences and/or generalizations drawn from the text.						
<a href="#">EO7.A-K.1.1.1</a>	Cite several pieces of textual evidence to support analysis of what the text says explicitly as well as inferences, conclusions, and/or generalizations drawn from the text.						
<a href="#">EO8.A-K.1.1.1</a>	Cite the textual evidence that most strongly supports an analysis of what the text says explicitly as well as inferences, conclusions, and/or generalizations drawn from the text.						
<a href="#">LF.2.1.1</a>	Make inferences and/or draw conclusions based on analysis of a text.						

# Writing

Content Code	Eligible Content	Grades					English Composition		
		K	1	2	3	4	5	Module 1 Informative/ Explanatory	Module 2 Argumentative
<b>Quality of Writing: Opinion/Argumentative: Focus &amp; Organization</b>									
<a href="#">CC.14.K.H</a>	Form an opinion by choosing between two given topics.	●							
<a href="#">CC.14.1.H</a>	Form an opinion by choosing among given topics.	■	●						
<a href="#">CC.14.2.H</a>	Identify the topic and state an opinion.		■	●					
<a href="#">E03.C.1.1.J</a>	Introduce the topic or text for the intended audience, state an opinion, and create an organizational structure that lists reasons to support the writer's purpose.			■	●				
<a href="#">E04.C.1.1.J</a>	Introduce a topic or text for the intended audience, state an opinion, and create an organizational structure in which related ideas are grouped to support the writer's purpose.				■	●			
<a href="#">E05.C.1.1.J</a>	Introduce a topic or text for the intended audience, state an opinion, and create an organizational structure in which ideas are logically grouped to support the writer's purpose.					■	●		
<a href="#">E06.C.1.1.J</a>	Introduce claim(s) for the intended audience and support the writer's purpose by organizing the reasons and evidence.						■		
<a href="#">E07.C.1.1.J</a>	Introduce claim(s) for the intended audience, acknowledge alternate or opposing claims, and support the writer's purpose by logically organizing the reasons and evidence.								
<a href="#">E08.C.1.1.J</a>	Introduce claim(s) for the intended audience, acknowledge and distinguish the claim(s) from alternate or opposing claims, and support the writer's purpose by logically organizing reasons and evidence.								
<a href="#">C.A.1.1.J</a>	Write argumentative pieces that include a clearly stated position made convincing through the use of appropriate methods. Write with a sharp, distinct controlling point that clearly states a position and demonstrates awareness of task, purpose, and audience.								●
<a href="#">C.A.1.13</a>	<b>Write argumentative pieces that include a clearly stated position made convincing through the use of appropriate methods.</b> Organize the argument using effective strategies to develop a strong, well-supported position.								●
<a href="#">CC.14.1.J</a>	Create an organizational structure that includes reasons and provides some sense of closure.		■	●					
<a href="#">CC.14.2.J</a>	Create an organizational structure that includes reasons and includes a concluding statement.		■	●					

# Newsletter-Coming this Month

- Coming soon 😊

- Theresa Bash's video on how to make PM work in Newrow
- She has made a District Library and many are already in the folders already!!

# Progress Monitoring in Newrow

Log into Nearpod

On the left hand tool bar when they log in they will see district library

Click on that there is a special education aimsweb folder. I have been working on uploading what I have. There is at least one probe for every grade in MCAP. I am working on MAZE.

• [https://365accs-my.sharepoint.com/:v:/g/personal/tbash\\_agora\\_org/EXMfHziyDVhAun6gDsJe6vsBbtH2A\\_aD3iEdqrs6w-sOgg?isSPOFile=1](https://365accs-my.sharepoint.com/:v:/g/personal/tbash_agora_org/EXMfHziyDVhAun6gDsJe6vsBbtH2A_aD3iEdqrs6w-sOgg?isSPOFile=1)

# Aimweb and PM in Newrow

- Emails from Michelle about this.
- Let us know if you have more questions about using New Row and Progress Monitoring

1. Summary						
Attended participants	18					
Start time	9/3/21, 9:54:07 AM					
End time	9/3/21, 11:18:59 AM					
Meeting duration	1h 24m 52s					
Average attendance time	1h 3m					
2. Participants						
Name	First join	Last leave	In-meeting duration	Email	Participant ID (UPN)	Role
Jennifer Buss	9/3/21, 9:54:23 AM	9/3/21, 11:18:47 AM	1h 24m 24s	jbuss@agora.org	jbuss@agora.org	Presenter
Carmen Riggle	9/3/21, 9:54:41 AM	9/3/21, 11:06:20 AM	1h 11m 38s	criggle@agora.org	criggle@agora.org	Presenter
Marlee Atwood	9/3/21, 9:55:10 AM	9/3/21, 11:06:35 AM	1h 11m 25s	matwood@agora.org	matwood@agora.org	Presenter
Erin Connor	9/3/21, 9:55:27 AM	9/3/21, 10:48:18 AM	52m 51s	econnor@agora.org	econnor@agora.org	Presenter
Ashley Schmidt	9/3/21, 9:58:02 AM	9/3/21, 10:57:54 AM	59m 51s	aschmidt@agora.org	aschmidt@agora.org	Presenter
Laurie Super	9/3/21, 9:58:15 AM	9/3/21, 11:18:59 AM	1h 20m 44s	lsuper@agora.org	lsuper@agora.org	Presenter
Janet Ulewicz	9/3/21, 9:58:17 AM	9/3/21, 11:06:45 AM	1h 8m 27s	julewicz@agora.org	julewicz@agora.org	Presenter
Regina Mallon	9/3/21, 9:58:40 AM	9/3/21, 11:08:58 AM	1h 10m 18s	gmallon@agora.org	gmallon@agora.org	Presenter
Brittney Walczak	9/3/21, 9:59:12 AM	9/3/21, 11:06:16 AM	1h 7m 3s	bwalczak@agora.org	bwalczak@agora.org	Presenter
Ashley Farster	9/3/21, 9:59:35 AM	9/3/21, 11:08:54 AM	1h 9m 18s	afarster@agora.org	afarster@agora.org	Presenter
Whitney Bargerstock	9/3/21, 9:59:48 AM	9/3/21, 11:11:24 AM	1h 11m 35s	wbargerstock@agora.org	wbargerstock@agora.org	Presenter
Michelle Cukauskas	9/3/21, 10:00:17 AM	9/3/21, 11:18:46 AM	1h 18m 29s	mcukauskas@agora.org	mcukauskas@agora.org	Organizer
Rachel Weeks	9/3/21, 10:00:21 AM	9/3/21, 11:06:17 AM	1h 5m 55s	rweeks@agora.org	rweeks@agora.org	Presenter
Cathrine Hartman	9/3/21, 10:00:32 AM	9/3/21, 11:06:34 AM	1h 6m 1s	chartman@agora.org	chartman@agora.org	Presenter
Olivia Eckels	9/3/21, 10:00:52 AM	9/3/21, 11:07:26 AM	35m 48s	oeckels@agora.org	oeckels@agora.org	Presenter
Casey Chaffin	9/3/21, 10:00:54 AM	9/3/21, 11:05:47 AM	1h 4m 53s	cchaffin@agora.org	cchaffin@agora.org	Presenter
Stefanie Marcello	9/3/21, 10:19:57 AM	9/3/21, 11:08:53 AM	48m 55s	smarcello@agora.org	smarcello@agora.org	Presenter
John Butler	9/3/21, 11:12:09 AM	9/3/21, 11:18:46 AM	6m 36s	jbutler@agora.org	jbutler@agora.org	Presenter
3. In-Meeting activities						
Name	Join time	Leave time	Duration	Email	Role	
Jennifer Buss	9/3/21, 9:54:23 AM	9/3/21, 11:18:47 AM	1h 24m 24s	jbuss@agora.org	Presenter	
Carmen Riggle	9/3/21, 9:54:41 AM	9/3/21, 11:06:20 AM	1h 11m 38s	criggle@agora.org	Presenter	
Marlee Atwood	9/3/21, 9:55:10 AM	9/3/21, 11:06:35 AM	1h 11m 25s	matwood@agora.org	Presenter	
Erin Connor	9/3/21, 9:55:27 AM	9/3/21, 10:48:18 AM	52m 51s	econnor@agora.org	Presenter	
Ashley Schmidt	9/3/21, 9:58:02 AM	9/3/21, 10:57:54 AM	59m 51s	aschmidt@agora.org	Presenter	
Laurie Super	9/3/21, 9:58:15 AM	9/3/21, 11:18:59 AM	1h 20m 44s	lsuper@agora.org	Presenter	
Janet Ulewicz	9/3/21, 9:58:17 AM	9/3/21, 11:06:45 AM	1h 8m 27s	julewicz@agora.org	Presenter	
Regina Mallon	9/3/21, 9:58:40 AM	9/3/21, 11:08:58 AM	1h 10m 18s	gmallon@agora.org	Presenter	
Brittney Walczak	9/3/21, 9:59:12 AM	9/3/21, 11:06:16 AM	1h 7m 3s	bwalczak@agora.org	Presenter	
Ashley Farster	9/3/21, 9:59:35 AM	9/3/21, 11:08:54 AM	1h 9m 18s	afarster@agora.org	Presenter	
Whitney Bargerstock	9/3/21, 9:59:48 AM	9/3/21, 11:11:24 AM	1h 11m 35s	wbargerstock@agora.org	Presenter	

Michelle Cukauskas	9/3/21, 10:00:17 AM	9/3/21, 11:18:46 AM	1h 18m 29s	mcukauskas@agora.org	Organizer	
Rachel Weeks	9/3/21, 10:00:21 AM	9/3/21, 11:06:17 AM	1h 5m 55s	rweeks@agora.org	Presenter	
Cathrine Hartman	9/3/21, 10:00:32 AM	9/3/21, 11:06:34 AM	1h 6m 1s	chartman@agora.org	Presenter	
Olivia Eckels	9/3/21, 10:00:52 AM	9/3/21, 10:33:50 AM	32m 58s	oeckels@agora.org	Presenter	
Olivia Eckels	9/3/21, 11:04:35 AM	9/3/21, 11:07:26 AM	2m 50s	oeckels@agora.org	Presenter	
Casey Chaffin	9/3/21, 10:00:54 AM	9/3/21, 11:05:47 AM	1h 4m 53s	cchaffin@agora.org	Presenter	
Stefanie Marcello	9/3/21, 10:19:57 AM	9/3/21, 11:08:53 AM	48m 55s	smarcello@agora.org	Presenter	
John Butler	9/3/21, 11:12:09 AM	9/3/21, 11:18:46 AM	6m 36s	jbutler@agora.org	Presenter	



# Exiting Students from Related Services

---

MELANIE STANFORTH

AGORA SPEECH  
LANGUAGE PATHOLOGIST



# 'Tis the season for related services exits

Lots of RS providers use the end of the year to wrap up therapy for students

Depending on the service being provided, students are dismissed in different ways





# RS Provider contacts you -

---

“Great news! Ariel found her voice and is no longer combing her hair with a fork. She’s ready for exit from speech and OT!”

Check Progress Reports – did the student show progress? Is there anything that seems strange?

Ask – did they discuss exiting from services with the family?

- It’s the provider’s responsibility to touch base with the family first
- The family doesn’t drive that decision, but surprise exits are no fun

## Recommendation for Related Services Discharge

**Date Completed:**

**Student's Name:**

**Related Services Provider Information:**

- Your Title (Mr/Ms/Miss/Mrs/Dr):
- Name (First and Last):
- Credentials:
- Type of related service provided:

**Therapeutic Progress**

- Please list current level of all IEP goals showing they are met, and/or detail lack of progress or carryover leading to exit. Quantitative Data must be included. Include any additional information that will help support decision to exit.

**Parent Input**

- Please include input/information provided by the parent/guardian regarding their opinion of their child's progress and their continuing concerns.

\*Please have this conversation with the parent before returning this form.

**Recommendation for Discharge**

- Clearly state reason to exit and why

**Additional Information and/or Descriptions**

# Step 1:

The provider must fill out the Recommendation for Related Service Discharge Form

# This is the data we need to move forward



We don't do standardized testing to exit students from related services

We use the data collection from the provider and input from all members of the student's team

- Educational Necessity!

When a provider reaches out to you stating that a student is ready to be exited from services, send them the form to fill out and return to you

# You have the RS Discharge Form...

---



# Let's start with Speech Therapy

Speech and Language  
Impairment is a  
*DISABILITY CATEGORY*

That's why there can be  
Speech Only IEPs

Speech exits are treated  
a little differently

## 6. CONCLUSIONS – Determination of Eligibility and Educational Needs

Complete A or B or C.

A.  The student does not have a disability and therefore is not eligible for special education.

OR

B.  The student has a disability but does not need specifically designed instruction, and therefore is not eligible for special education.

OR

C.  The student has a disability AND is in need of specifically designed instruction, and therefore IS eligible for special education.

1. Disability Category

Primary disability category: Speech and Language Impairment

Secondary disability category:

# A Reevaluation Report needs to be written to exit students from speech therapy!!



This is unique to speech therapy

It DOES NOT change a student's triennial reevaluation report date

It's a stand-alone RR that is necessary to remove Speech Language Impairment as a disability category

*No extra work for you!*

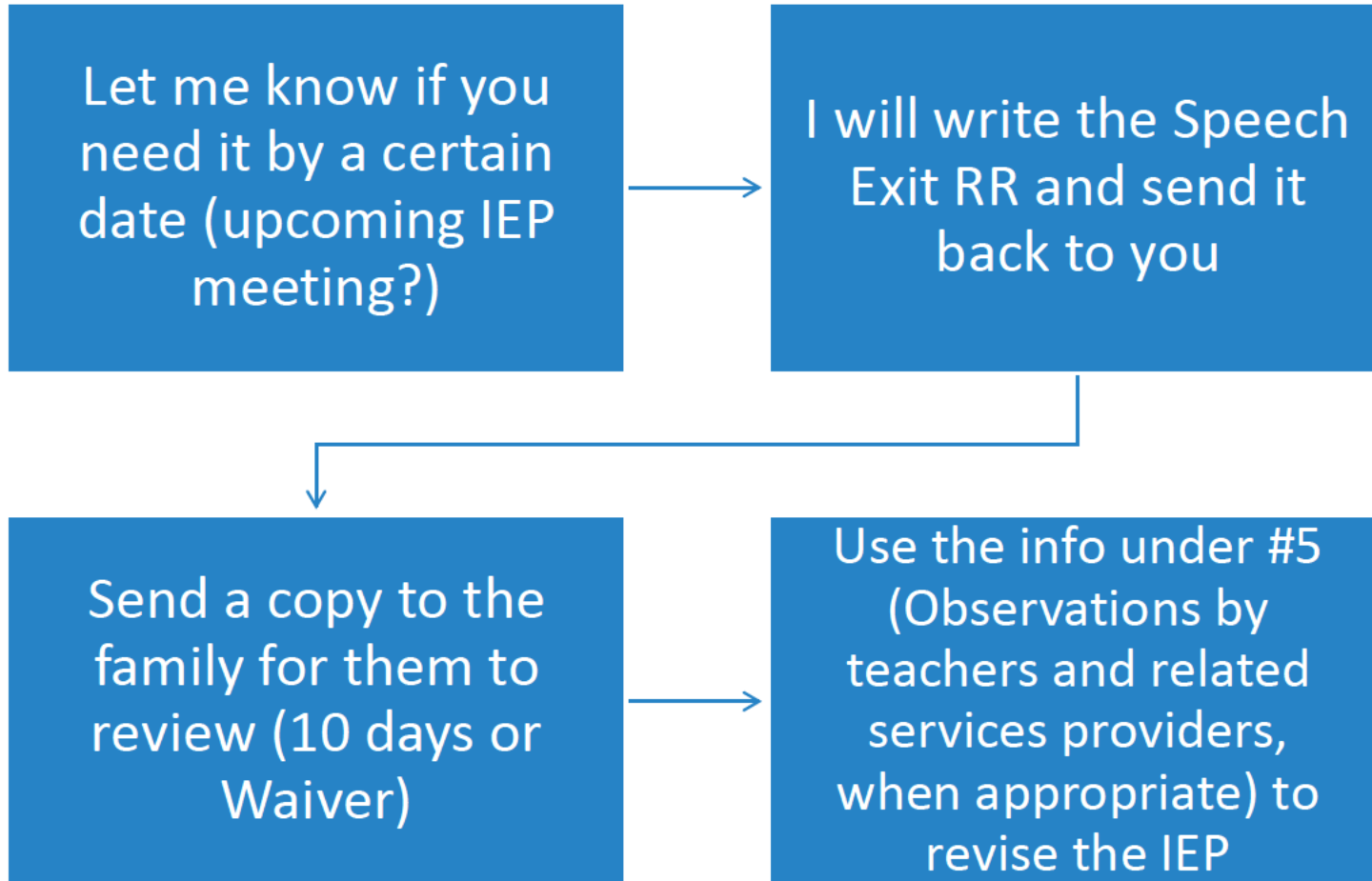

Step 2 for Speech:  
Send me the Recommendation for Related Service Discharge Form





**Make sure related services don't just magically disappear!**

# Removing Speech from an IEP...

Special Considerations

Present Levels of Functional Performance

Needs

Goals

SDIs

Related Services Grid

Supports for School Personnel

Educational Placement

Penn Data

NOREP

# Step 2 for Exiting Other RS:

---

No Exit RR needed if the RS isn't a disability category

Once you receive the Recommendation for Related Service Discharge Form you can revise the IEP

- Present Levels of Functional Performance
- Needs
- Goals
- SDIs
- Related Services
- Supports for School Personnel
- Educational Placement
- Penn Data
- NOREP





# A few housekeeping items...

---

The RS provider needs to continue providing services until the IEP is revised and the NOREP is signed.

Send the Speech Exit RR via Docs to File with everything else



Document, document, document!

It's a team decision to exit a student from related services

As always, all decisions are driven by *EDUCATIONAL NECESSITY*

A hand holding a sign that says "ANY QUESTIONS?". The sign is white with a black border and is held by a hand with a black sleeve. The background is red.

**ANY  
QUESTIONS?**

Please don't  
hesitate to reach  
out any time you  
have a question  
about Related  
Services!

# Quick Reference Guide

---

## Speech Therapy Exit

Confer with IEP team

Check Progress Reports

Send Recommendation for Related Service Discharge Form to RS provider

Contact Melanie to write Speech Exit RR

Send RR to family

Revise IEP to remove speech

- Special Considerations
- Present Levels of Functional Performance
- Needs
- Goals
- SDIs
- Related Services gird
- Educational Placement
- (Transition if necessary)

## Other Related Services Exit

Confer with IEP team

Check Progress Reports

Send Recommendation for Related Service Discharge Form to RS provider

Revise IEP to remove speech

- Present Levels of Functional Performance
- Needs
- Goals
- SDIs
- Related Services gird
- Educational Placement
- (Transition if necessary)



*Thank you!!*

---

Event Title: Exiting Students from Related Services													
Location: Teams Link in Details													
Start Date: 04/21/2022 2:00 PM													
<b>SLOT - 04/21/2022 2:00 PM</b>													
Educator First Name	Educator Last Name	Educator Local ID	Educator School	Presenter	Status	Signup Date	Waitlist Date	Hrs	Signed In	Approval	Credits Released	Comment	User Id
Brittney	Cantwell	6989082	Elementary School		Approved	04/05/2022 8:38 AM		1.0	Yes	04/21/2022	Yes		720508
Casey	Chaffin	9075298	Elementary School		Approved	04/05/2022 8:38 AM		1.0	Yes	06/08/2022	Yes		720296
Ashley	Farster	2480142	Elementary School		Approved	04/05/2022 8:38 AM		1.0	Yes	04/21/2022	Yes		720452
Amanda	Gruszewski		Elementary School		Approved	04/05/2022 8:38 AM		1.0	Yes	04/21/2022	Yes		720623
Cathrine	Hartman	3606539	Elementary School		Approved	04/05/2022 8:38 AM		1.0	Yes	04/21/2022	Yes		720520
Amber	Heppenstell	7315086	Elementary School		Approved	04/05/2022 8:38 AM		1.0	No	04/21/2022	Yes		908403
Carmen	Riggle	9076017	Elementary School		Approved	04/05/2022 8:38 AM		1.0	Yes	04/21/2022	Yes		720770
Brittney	Walczak		Elementary School		Approved	04/05/2022 8:38 AM		1.0	No	04/21/2022	Yes		720553
Jennifer	Buss	5732496	Elementary School		Approved	04/05/2022 8:40 AM		1.0	Yes	04/21/2022	Yes		720451
Erin	Connor	2614786	Elementary School		Approved	04/05/2022 8:40 AM		1.0	Yes	04/21/2022	Yes		720843
Gillian	Kaufman	7598317	Elementary School		Approved	04/05/2022 8:40 AM		1.0	Yes	04/21/2022	Yes		720772
Kristen	Moore	6383075	Elementary School		Approved	04/05/2022 8:40 AM		1.0	No	04/21/2022	Yes		853909
Dana	O'Donnell	5397505	Elementary School		Approved	04/05/2022 8:40 AM		1.0	No	04/21/2022	Yes		720432
Janet	Ulewicz	1953249	Elementary School		Approved	04/05/2022 8:40 AM		1.0	Yes	04/21/2022	Yes		720638
Olivia	Eckels	1835849	Elementary School		Approved	04/05/2022 8:42 AM		1.0	Yes	04/21/2022	Yes		720378
Melissa	Franklin	4904954	Elementary School		Approved	04/05/2022 8:42 AM		1.0	Yes	04/21/2022	Yes		720361
Kristina	Lapsker	9379892	Elementary School		Approved	04/05/2022 8:42 AM		1.0	Yes	04/21/2022	Yes		720599
Kristine	Lorcheim		Elementary School		Approved	04/05/2022 8:42 AM		1.0	Yes	04/21/2022	Yes		730338
Stephanie	Mannarino	8037641	Elementary School		Approved	04/05/2022 8:42 AM		1.0	Yes	04/21/2022	Yes		720495
Stefanie	Marcello	9431073	Elementary School		Approved	04/05/2022 8:42 AM		1.0	No	04/21/2022	Yes		720609
Sarah	Pittman	8023861	Elementary School		Enrolled	04/05/2022 8:42 AM		0.0	No		No		720505
Regina	Mallon	1907396	Elementary School		Approved	04/05/2022 8:42 AM		1.0	Yes	04/21/2022	Yes		720850
Michelle	Cukauskas	2427256	Elementary School		Approved	04/05/2022 8:43 AM		1.0	No	04/21/2022	Yes		720401
Maryann	Johnson	9682934	K-8		Enrolled	04/05/2022 8:43 AM		0.0	No		No		720459
Anna	Lepsch	6850415	K-8		Enrolled	04/05/2022 8:43 AM		0.0	No		No		720542
Laurie	Super	8068396	Elementary School		Approved	04/05/2022 8:43 AM		1.0	Yes	04/21/2022	Yes		720453
Kelly	Berstecher	3460531	Middle School		Approved	04/05/2022 8:43 AM		1.0	Yes	04/21/2022	Yes		720694
Heidi	Dodge	2569601	K-8		Approved	04/05/2022 8:43 AM		1.0	No	04/21/2022	Yes		720854
David	Furka	5839145	Middle School		Enrolled	04/05/2022 8:43 AM		0.0	No		No		720587
KyMBERly	Humanick	3547971	K-8		Enrolled	04/05/2022 8:43 AM		0.0	No		No		720536
Jessica	Linderman	9045025	Middle School		Approved	04/05/2022 8:43 AM		1.0	Yes	04/21/2022	Yes		720562
Cathryn	Mack	9457194	K-8		Approved	04/05/2022 8:43 AM		1.0	No	04/21/2022	Yes		720601
Brittany	Reamer	9891649	Middle School		Enrolled	04/05/2022 8:43 AM		0.0	No		No		720710
Marlee	Atwood	7279386	Middle School		Approved	04/05/2022 8:44 AM		1.0	Yes	04/21/2022	Yes		720804



<b>Educator First Name</b>	<b>Educator Last Name</b>	<b>Educator Local ID</b>	<b>Educator School</b>	<b>Presenter</b>	<b>Status</b>	<b>Signup Date</b>	<b>Waitlist Date</b>	<b>Hrs</b>	<b>Signed In</b>	<b>Approval</b>	<b>Credits Released</b>	<b>Comment</b>	<b>User Id</b>
Maria	Harlan	8209824	K-8		Approved	04/05/2022 8:44 AM		1.0	Yes	04/21/2022	Yes		720797
Leslie	Spratt	2579716	Middle School		Enrolled	04/05/2022 8:44 AM		0.0	No		No		720660
Melanie	Stanforth	1534506	K-12		Approved	04/05/2022 8:44 AM		1.0	No	04/21/2022	Yes		720480
Lauren	Svonavec	6873915	Middle School		Approved	04/05/2022 8:44 AM		1.0	Yes	04/21/2022	Yes		720463
Molly	Garczynski	8048158	Middle School		Approved	04/05/2022 8:45 AM		1.0	Yes	04/21/2022	Yes		720414
Michelle	Pelissier	1391528	K-8		Approved	04/05/2022 8:45 AM		1.0	No	06/05/2022	Yes		720394
Stacy	Vietmeier	5735753	K-8		Approved	04/05/2022 8:45 AM		1.0	Yes	04/21/2022	Yes		720758
Kimberly	Paolino	3172707	Middle School		Enrolled	04/05/2022 8:45 AM		0.0	No		No		720588
Jennifer	Fisher-Clark	8961729	Middle School		Enrolled	04/05/2022 8:46 AM		0.0	No		No		720404

# Professional Responsibilities Agenda August 2020

- Agenda
  - Special Ed Shared Drive
  - Tyler Communication Log
  - Email Etiquette
  - Paperwork Responsibilities
  - IEP's-Roles and Responsibilities
  - Aimsweb Plus
  - Progress Monitoring
  - Progress Reports
  - Attendance
  - Directives/Meeting Timelines
  - Lesson Plans
  - Docs 2 File
  - Related Services
  - Replacement Curriculum
  - Assistive Technology Requests
  - Instructional Coaches
  - Procedures-Where To?
  - PAETEP
  - Beginning of Year Timeline



Timestamp	Email Address	Name	PPID	Supervisor	
8/11/2020 16:09:17	eslacktish@agora.org	First Name	Last Name	ANSWER KEY	
8/10/2020 16:17:54	bfroehlich@agora.org	Brittany	Froehlich	5897815	Lucia
8/11/2020 9:47:35	lolbryk@agora.org	Lacey	Olbryk	8725401	Lucia
8/11/2020 14:10:36	asweeney@agora.org	Allison	Sweeney	6797603	Natale
8/11/2020 14:39:46	cmack@agora.org	Cathryn	Mack	9457194	Johnson
8/11/2020 15:46:09	twalker@agora.org	Tara	Walker		Schall
8/11/2020 22:22:43	lsvonavec@agora.org	Lauren	Svonavec	6873915	Johnson
8/12/2020 7:39:19	bscears@agora.org	Breanne	Scears	2918713	Val Natale
8/12/2020 9:11:40	jshaffer3@agora.org	Janelle	Shaffer	1783096	Freyvogel
8/12/2020 9:15:59	kbeadle@agora.org	Karla	Beadle		Cukauskas
8/12/2020 12:09:49	jdepietro@agora.org	Jenn	DePietro	1051274	Witman
8/12/2020 12:35:02	jdeemer@agora.org	Judy	Deemer		Natale
8/12/2020 15:02:45	jbeeken@agora.org	Jennifer	Beeken	1431604	Freyvogel
8/12/2020 20:06:27	bcantwell@agora.org	Brittney	Cantwell	6989082	Johnson
8/13/2020 10:07:21	svietmeier@agora.org	Stacy	Vietmeier	5735753	Johnson
8/13/2020 10:45:26	aschmidt@agora.org	Ashley	Schmidt	6546756	Cukauskas
8/13/2020 11:28:25	cbarkley@agora.org	Cortney	Barkley	9674013	Lucia
8/13/2020 13:36:30	lstapf@agora.org	Laura	Stapf	5026504	Natale
8/13/2020 13:59:15	chartman@agora.org	Cathrine	Hartman	3606539	Cukauskas
8/13/2020 15:48:05	slelko@agora.org	Susan	Lelko	9089175	Natale
8/13/2020 15:48:19	nreimers@agora.org	Nancy	Reimers	6041706	Schall
8/14/2020 13:51:48	rperri@agora.org	Renee	Perri	1810325	Natale
8/14/2020 14:24:45	cganter@agora.org	Crysta	Ganter	1673067	Cukauskas
8/14/2020 17:38:21	lbrestensky@agora.org	Lisa	Brestensky	8491596	Freyvogel
8/14/2020 22:27:50	jreese@agora.org	Jessica	Reese	5207967	Lucia
8/17/2020 8:13:08	ckirchner@agora.org	Carly	Kirchner	6725723	Freyvogel
8/17/2020 10:45:27	cbryan@agora.org	Carol	Bryan	6408509	Cukauskas
8/17/2020 13:10:54	jfecik@agora.org	Justine	Fecik	1607938	Schall
8/17/2020 13:37:32	dfurka@agora.org	David	Furka	5839145	Johnson
8/17/2020 13:39:05	jhuffman@agora.org	Jena	Huffman	7165636	Natale
8/17/2020 20:06:34	klapsker@agora.org	Kristina	Lapsker		

<b>Timestamp</b>	<b>Email Address</b>	<b>Name</b>		<b>PPID</b>	<b>Supervisor</b>
8/18/2020 11:05:17	aarmstrong@agora.org	Amanda	Armstrong	1830841	Freyvogel
8/18/2020 11:05:19	mgaso@agora.org	Melissa	Gasco	1678431	Natale
8/18/2020 11:48:33	nkrol@agora.org	Nicole	Krol	8487304	Freyvogel
8/18/2020 12:19:35	kfitzgerald@agora.org	Kim	Fitzgerald	7953824	Lucia
8/18/2020 13:35:37	jdunlap@agora.org	Jill	Dunlap	3951391	Freyvogel
8/18/2020 13:39:38	lradico@agora.org	Lauren	Radico	5674767	Freyvogel
8/18/2020 13:57:21	dodonnell@agora.org	Dana	O'Donnell	5397505	Johnson
8/18/2020 15:21:25	oeckels@agora.org	Olivia	Eckels	1835849	Cukauskas
8/18/2020 15:38:49	slipiec@agora.org	Susan	Lipiec	7462653	Lucia
8/18/2020 15:51:27	jcapitano@agora.org	Jesse	Capitano	8981801	Freyvogel
8/18/2020 16:32:45	mstump@agora.org	Melissa	Stump	8359342	Natale
8/18/2020 17:23:11	adenham@agora.org	Angie	Denham	5837679	Witman
8/18/2020 19:19:32	kcostanzo@agora.org	Kristal	Costanzo	4721493	Lucia
8/19/2020 12:29:00	cpanchura@agora.org	Chelsey	Panchura	5735207	Freyvogel
8/19/2020 13:04:57	lspratt@agora.org	Leslie	Spratt	2579716	Johnson
8/19/2020 13:28:28	kwelsh@agora.org	Kristy	Welsh	3715812	Natale
8/19/2020 14:04:01	thunkele@agora.org	Terri	Hunkele	7871924	Schall
8/19/2020 14:17:41	jdietrich@agora.org	Jenna	Dietrich	4096064	Lucia
8/19/2020 18:33:36	astaley2@agora.org	Amber	Staley	2865256	Freyvogel
8/19/2020 20:04:12	mpelissier@agora.org	Michelle	Pelissier	1391528	Johnson
8/19/2020 20:59:44	hsilberman@agora.org	Heather	Silberman		Schall
8/19/2020 21:11:16	jmoyer2@agora.org	Jill	Moyer		Schall
8/20/2020 13:30:53	rcongdon@agora.org	Rebekah	Congdon	5045706	Schall
8/20/2020 21:31:40	jbarnhart@agora.org	Jessica	Barnhart	4590197	Lucia
8/21/2020 9:26:40	mlove@agora.org	Melissa	Love	1097861	Schall
8/21/2020 9:50:17	tdraeger@agora.org	Theresa	Draeger	1585189	Schall
8/21/2020 12:44:58	jzollman@agora.org	Jennifer	Zollman	8725829	Natale
8/21/2020 23:42:12	mgarczynski@agora.org	Molly	Garczynski	8048158	Johnson
8/22/2020 10:20:46	alarge@agora.org	Allison	Large	7934971	Freyvogel
8/22/2020 13:49:32	skennedy@agora.org	Sabrina	Kennedy	8258565	Natale

Timestamp	Email Address	Name		PPID	Supervisor
8/23/2020 10:02:27	lkerns@agora.org	Lauren	Kerns	6463102	Natale
8/23/2020 16:54:22	syoun@agora.org	Sasha	Young	6136347	Schall
8/23/2020 17:39:05	amalec@agora.org	Ashley	Malec	1652126	Lucia
8/23/2020 17:46:49	dpacolay@agora.org	Dana	Pacolay	5325374	Freyvogel
8/23/2020 18:00:49	jseverino@agora.org	Jill	Severino	1205208	Lucia
8/23/2020 20:09:34	abrisbane@agora.org	Amber	Brisbane	3612063	Witman
8/24/2020 4:47:10	hcobert@agora.org	Heather	Cobert	4102713	Freyvogel
8/24/2020 9:26:21	cemrick@agora.org	Carissa	Emrick	5403689	Schall
8/24/2020 10:02:30	jbuss@agora.org	Jennifer	Buss	5732496	Cukauskas
8/24/2020 10:23:14	lpagliei@agora.org	Lynn	Pagliei	3109573	Schall
8/24/2020 10:30:20	gmallon@agora.org	Regina	Mallon	1907396	Cukauskas
8/24/2020 10:31:07	afarster@agora.org	Ashley	Farster	2480142	Cukauskas
8/24/2020 11:20:45	tambuka@agora.org	Tracey	Ambuka	2941592	Freyvogel
8/24/2020 14:47:00	akimmage@agora.org	Amanda	Moyer	3056185	Schall
8/24/2020 15:18:03	gfiscus@agora.org	Grace	Fiscus	8105219	Cukauskas
8/24/2020 16:55:32	cbaker@agora.org	Chris	Baker	6760832	Lucia
8/24/2020 19:29:17	kpaolino@agora.org	Kim	Paolino	3172707	Johnson
8/24/2020 20:00:40	jlinderman@agora.org	Jessica	Linderman	9045025	Johnson
8/24/2020 20:06:37	cwiddop@agora.org	Christen	Widdop	6597585	Cukauskas
8/24/2020 20:12:17	bpontious@agora.org	Brianna	Pontious	9616535	Lucia
8/24/2020 21:35:20	bfink@agora.org	Brittany	Fink	9891649	Johnson
8/24/2020 23:34:43	jdoebereiner@agora.org	Julie	Doebereiner	7489562	Lucia
8/25/2020 7:09:21	lsavitz@agora.org	Lisa	Savitz	6402734	Schall
8/25/2020 7:51:17	lsavitz@agora.org	Lisa	Savitz	6402734	Schall
8/25/2020 8:16:48	gdonch@agora.org	Gina	Rodriguez	3791683	Cukauskas
8/25/2020 14:24:16	jcadioux@agora.org	Jenn	Cadioux	2746171	Freyvogel
8/25/2020 15:32:19	hdodge@agora.org	Heidi	Dodge	2569601	Johnson
8/26/2020 12:28:55	cramsey@agora.org	Cathryn	Ramsey	8190103	Lucia
8/26/2020 12:32:17	ehenretta@agora.org	Erikka	Henretta	1872897	Cukauskas
8/26/2020 12:45:28	mbasso@agora.org	Maura	Basso	6941361	Lucia

<b>Timestamp</b>	<b>Email Address</b>	<b>Name</b>		<b>PPID</b>	<b>Supervisor</b>
8/31/2020 13:21:53	mbotti@agora.org	Michelle	Botti	9294146	Lucia
9/1/2020 13:51:36	khoffman@agora.org	Kaelyn	Hoffman	5371396	Lucia
9/3/2020 10:23:57	kshannon@agora.org	Keri	Shannon	5341385	Natale
9/7/2020 13:21:15	bcooper@agora.org	Barb	Cooper		Schall
9/8/2020 11:11:54	mmccracken@agora.org	Melissa	McCracken	7467268	Freyvogel
9/15/2020 9:25:05	llamison@agora.org	Lauren Lamison		9614984	Natale
9/15/2020 9:46:24	scostello@agora.org	Serena Costello		6237909	Natale
9/15/2020 11:00:20	nhollenbach@agora.org	Nicolette Hollenbach		5776786	Natale
9/16/2020 15:45:42	araught@agora.org	Amy Raught		4603802	Freyvogel
9/16/2020 22:36:17	tkozak@agora.org	Tamara Kozak		2986176	Natale
9/29/2020 11:14:06	hgallagher@agora.org	Heather Gallagher		7959715	Natale
10/8/2020 16:17:43	akammermeier@agora.or	Amanda Kammermeier		2010834	Natale

A top-down view of a spiral-bound notebook on a wooden desk. The notebook is filled with hand-drawn curriculum maps for ELA. The maps are organized into several pages, each showing a sequence of units or lessons. The drawings use various colors (green, red, blue) and arrows to indicate flow and relationships between different parts of the curriculum. A person's hand is visible in the bottom right corner, holding a pencil and pointing at one of the maps. The overall scene suggests a teacher or curriculum developer in the process of planning or refining their curriculum.

# Modified Curriculum ELA

2/10/22

# Connecting Grade Level & Instructional Content

- How are you currently connecting grade level content to the students instructional levels?



# Vertical Alignment-Standards & Pre-Req's

# Atlas

## Gr 3 ELA Gen Ed Authors Purpose

1. CC.1.3.3.B Ask and answer questions about the text and make inferences from text, referring to text to support responses.
2. CC.1.3.3.C Describe characters in a story and explain how their actions contribute to the sequence of events.
3. CC.1.3.3.G Explain how specific aspects of a text's illustrations contribute to what is conveyed by the words in a story (e.g., create mood, emphasize aspects of a character or setting).
4. CC.1.3.3.H Compare and contrast the themes, settings, and plots of stories written by the same author about the same or similar characters.
5. CC.1.3.3.K Read and comprehend literary fiction on grade level, reading independently and proficiently.

# Welcome to Language Arts

Try this link for your spelling word practice:

By the end of class you will :



- Be able to correctly **Summarize** our story, The Sign Painter
- Define and correctly identify the **author's purpose** for writing a text.
- **Explain** what **parts** of the text you used in order to help you figure out the **author's purpose**.

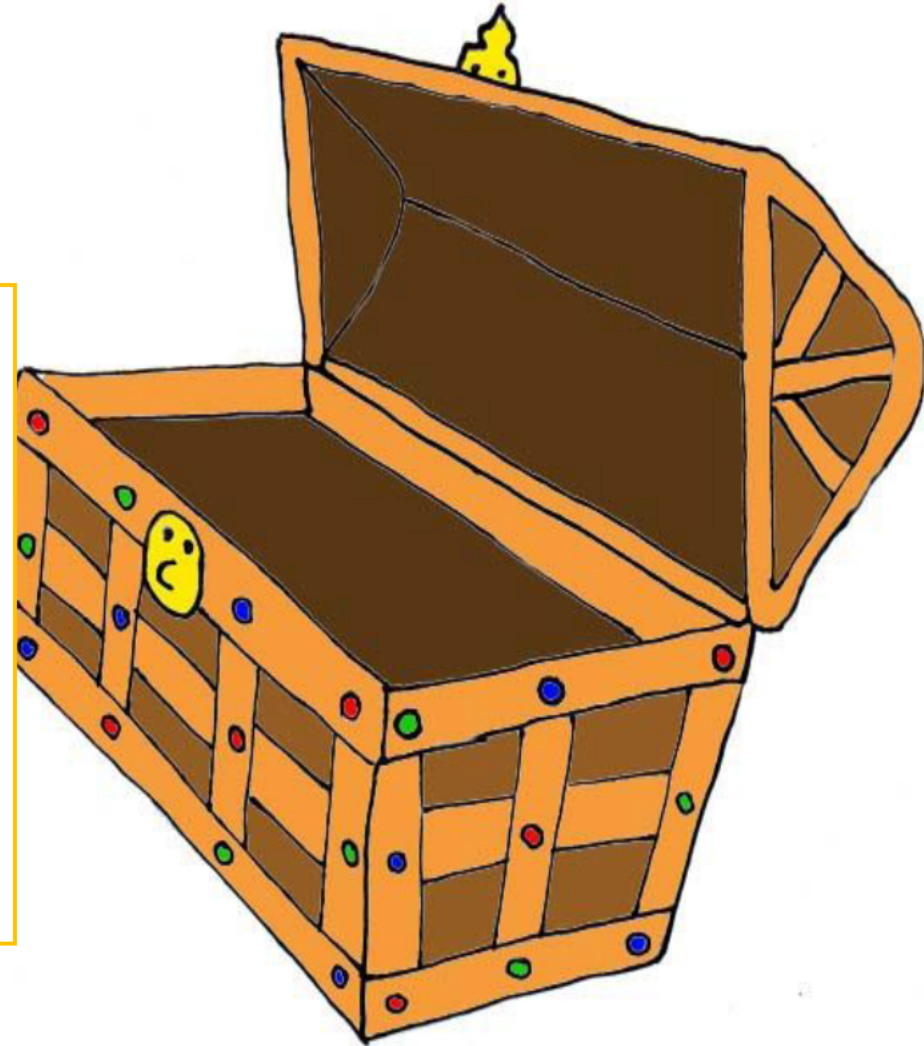

# Recall and summarize with a tear

Work with your team to complete the summary. Circle the correct word in blue.

## Good Readers: Recall and Summarize

Good readers can remember what they've read and retell the main points.

The story was About...



I really liked This story because First...then...and Finally...



Early one morning a young man arrived in the town on a bus/train. He was looking for a friend/job. The sign painter hired him to help paint landscapes/billboards. They drove into the desert/mountains to begin working. The young man wanted to paint mountains/rivers, but he could only paint a woman's face and the word Arrowstar/North Star.

On their last night in the desert that got stuck in a rainstorm/dust storm. The next morning they discovered that the last billboard was destroyed by the wind. In the distance they saw a huge towers/buildings. As they drove closer, they saw that it was a skyscraper/rollercoaster. There was also a group of empty houses on a rock. Inside one of the houses they heard a man/woman talking on the phone.

At the end of the story the young man said goodbye to the sign painter and left the town.

# EdPuzzle

- Let's try something new:

- Link: <https://edpuzzle.com/media/61433d5b1b2c0f416b848ea9>

1. Open the link
2. Listen to the video
3. Answer the questions as they appear during the video
4. Click the green check to submit 😊

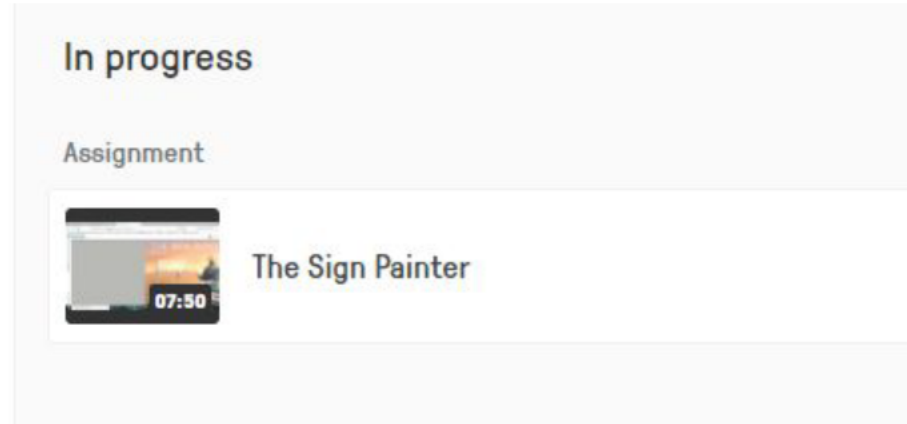

# Welcome to Language Arts

Try this link for your spelling word practice:

By the end of class you will :



- Define and correctly identify the **author's purpose** for writing a text.
- **Explain** what **parts** of the text you used in order to help you figure out the **author's purpose**.
- Review each of our Allen Say books together to get ready for our assessment.
- Complete an assessment on Allen Say and his books, *Grandfather's Journey*, *Tea with Milk* and *The Sign*

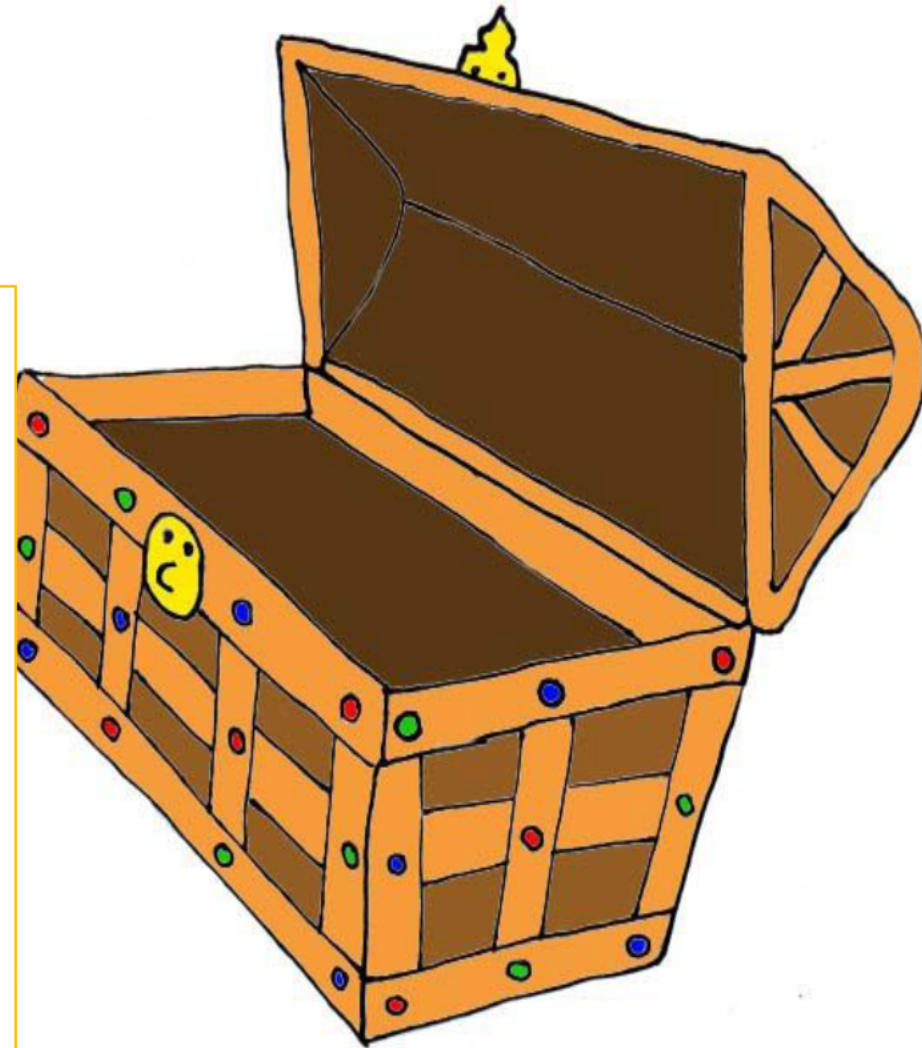



# Edpuzzle



What does the sign painter ask the young man to paint?

They drove to a vacant lot where a blank billboard had been set up.

“This is your model,” the man said, showing the boy a picture of a woman.

“I want her on the right, as big as you can make her.”

The boy worked quickly; he outlined a face taller than himself and then began to paint. At lunchtime the man said, “You seem to know what you’re doing.”



# Edpuzzle



What does the young man want to paint?

- A walls
- B pictures of people
- C advertisements
- D landscapes

They started out early the following morning.

“We’ll be working in the desert,” the man said.

“I like painting landscapes,” the boy said.

“You’re painting a woman, just the way the layout shows. Goes with one word, ArrowStar. That’s it.”

“What is ArrowStar?”

“I didn’t ask,” replied the man.

By midafternoon they were driving into the desert.

# Edpuzzle



How does the boy respond when the man asks if he wants to work together again?

- A He says yes.
- B He doesn't say anything.
- C He says no.

They coasted down the ramp. Neither said a word until ArrowStar was behind them.

“Will he succeed?” the man asked.

“I hope so,” the boy answered.

“Goes to show that dreams come in all sizes. But we’re done, for now. How do you feel about working with me?”

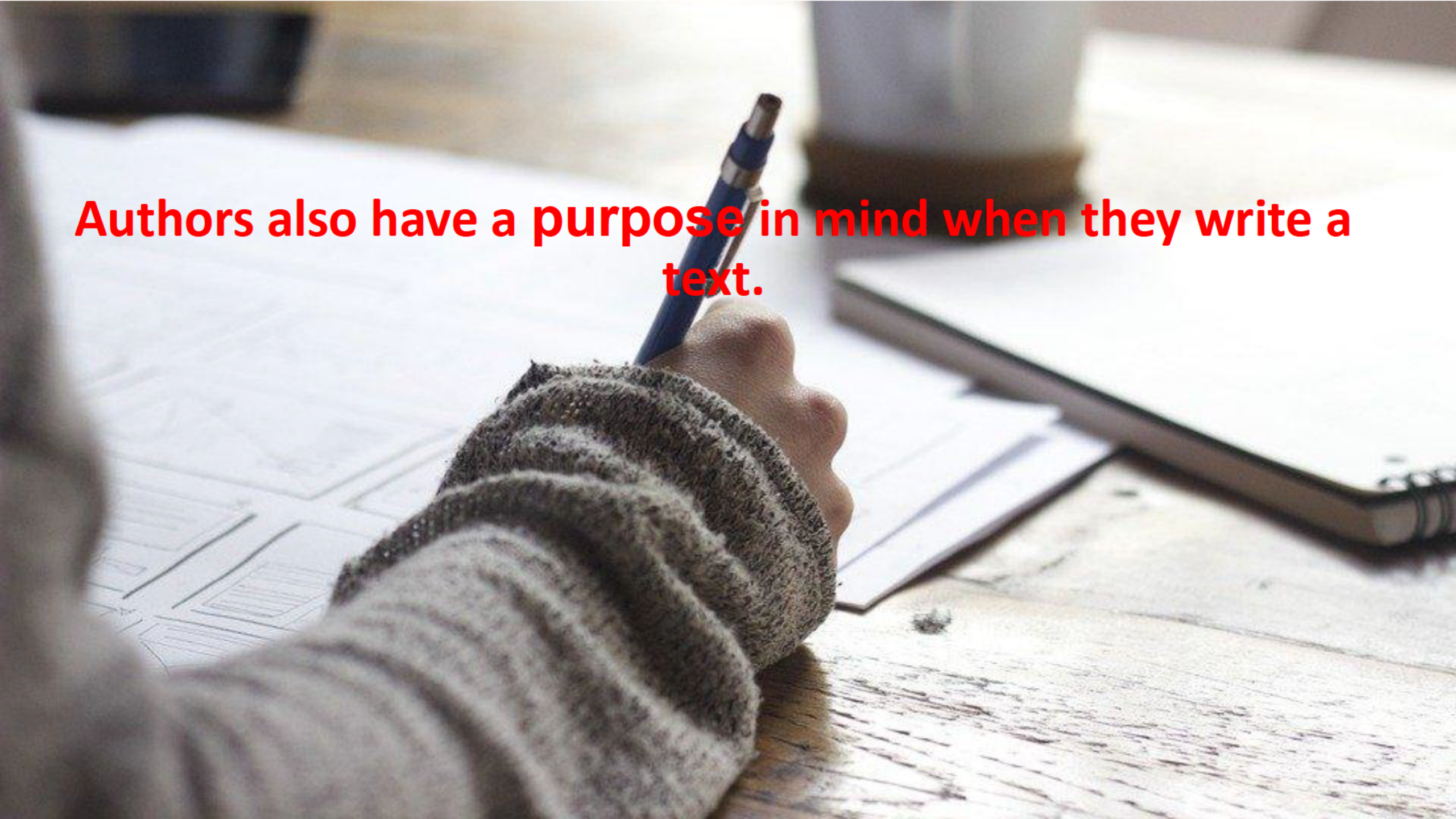

The boy said nothing.

**Authors also have a purpose in mind when they write a text.**

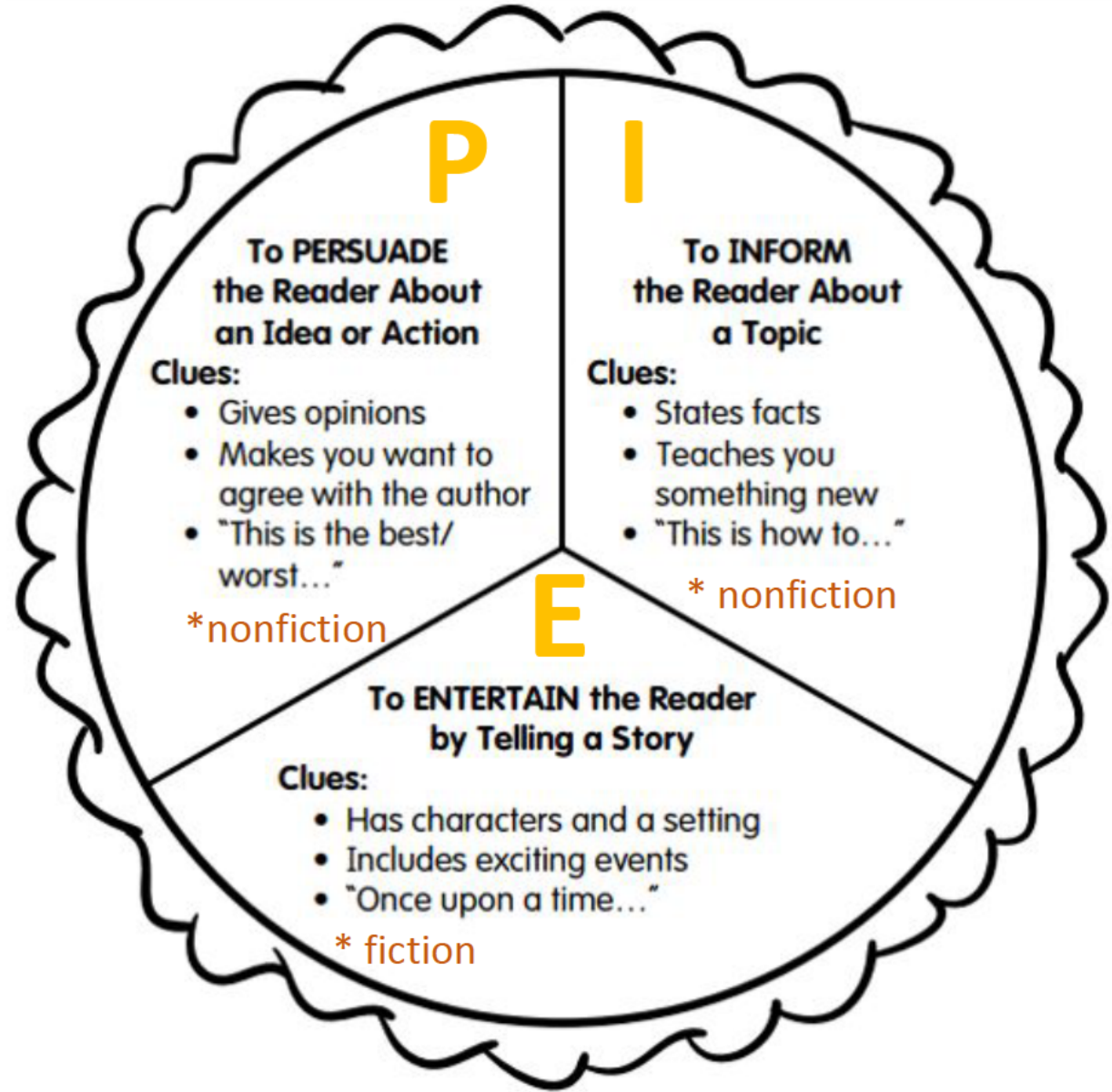

**Author's Purpose**  
is the reason the  
author wrote  
the text.

The  
**Author's Purpose**  
is all  
about  
**PIE!**



# Persuade

The author tries to get you to do something or believe what he is saying.  
or she

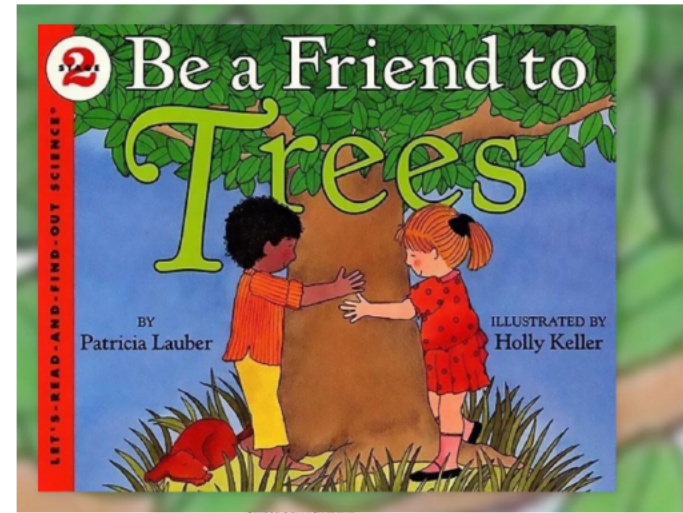
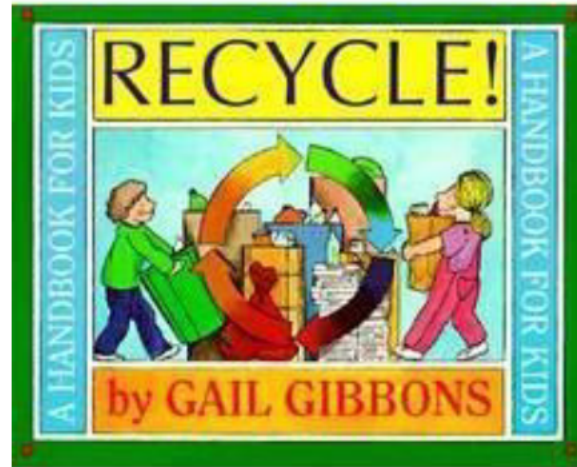

# Inform



The author gives you information about a topic.

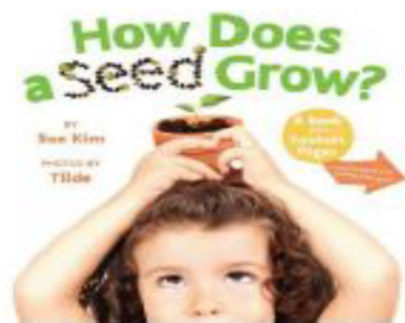
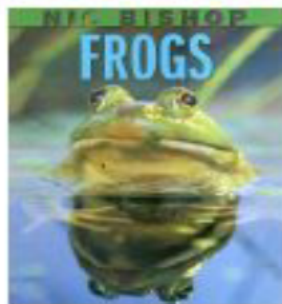
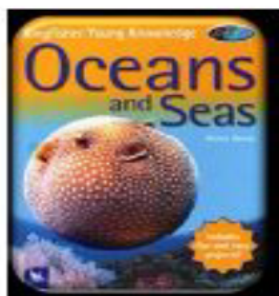

# Entertain



The author tells us a story that we will enjoy.

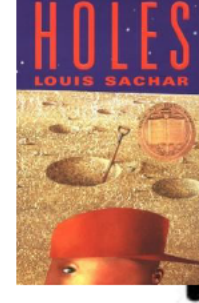
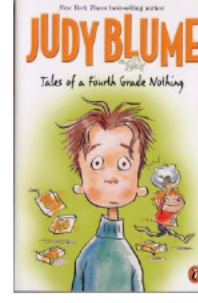
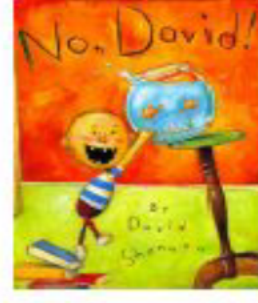
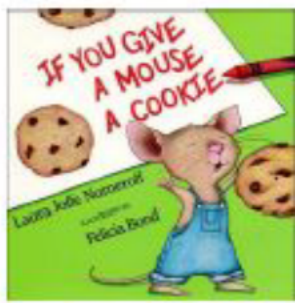
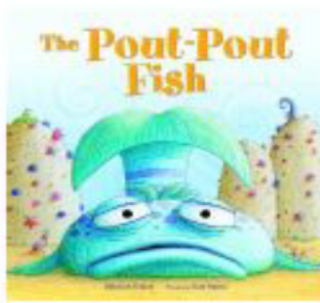
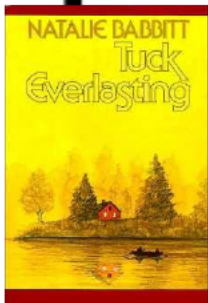



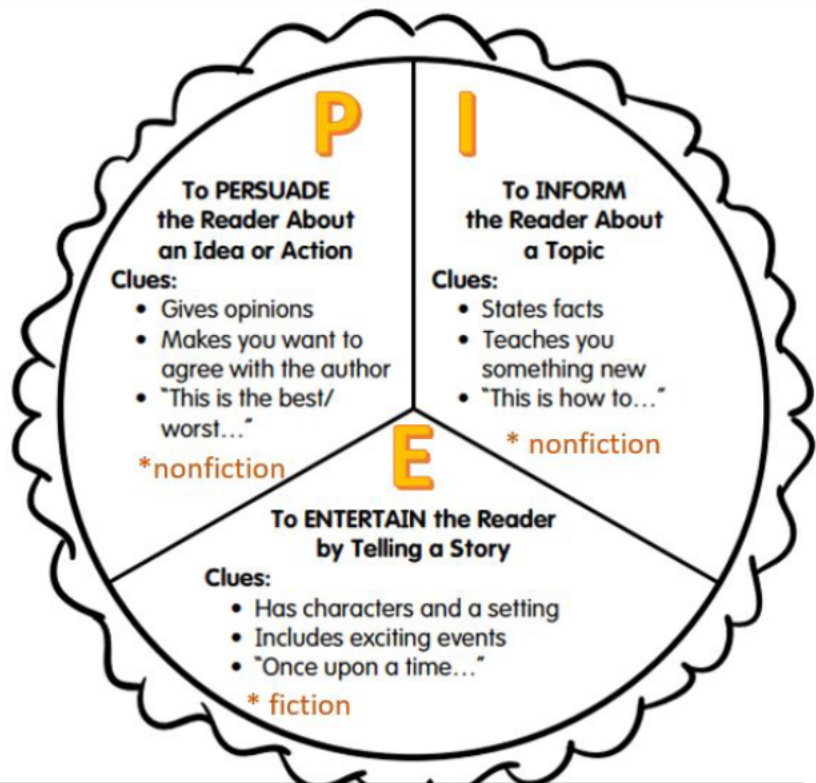

Is Allen Say giving his opinion or trying to get us to agree with him?

Is he teaching us something or sharing facts with us?

Is telling a story with characters and a setting?

Allen Say wrote *The Sign Painter* to \_\_\_\_\_ the reader.

I know because \_\_\_\_\_.



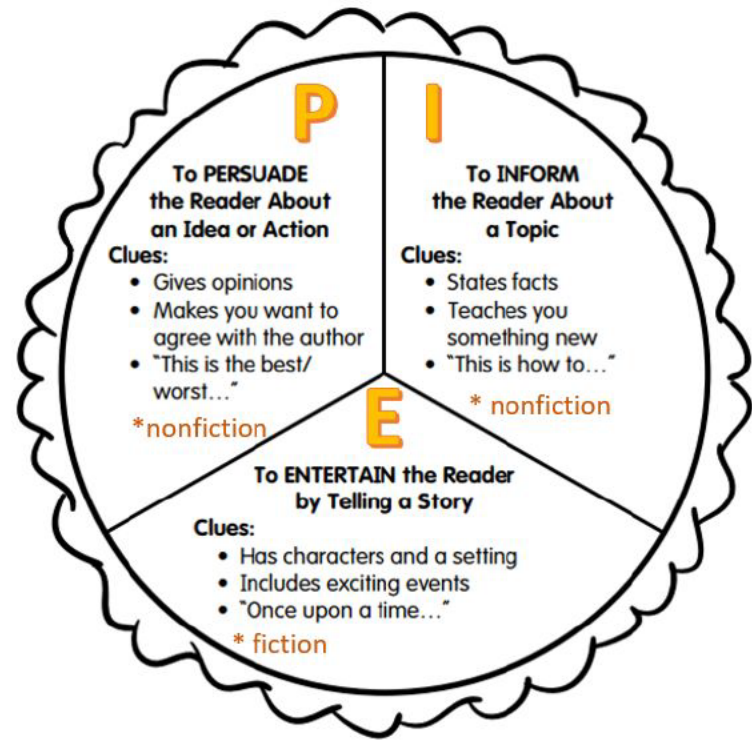

Work with your team. Questions 1-3: Circle **green check** or **red X**.  
Questions 4 and 5: Fill in the blanks. If you have time, try the activity on the 3<sup>rd</sup> page.



1. Is Allen Say **giving his opinion** or trying to **get us to agree with him**?



2. Is he **teaching** us something or sharing **facts** with us?



3. Is telling a story with **characters** and a **setting**?

4. Allen Say wrote *Grandfather's journey* to \_\_\_\_\_ the reader.

5. I know because \_\_\_\_\_.

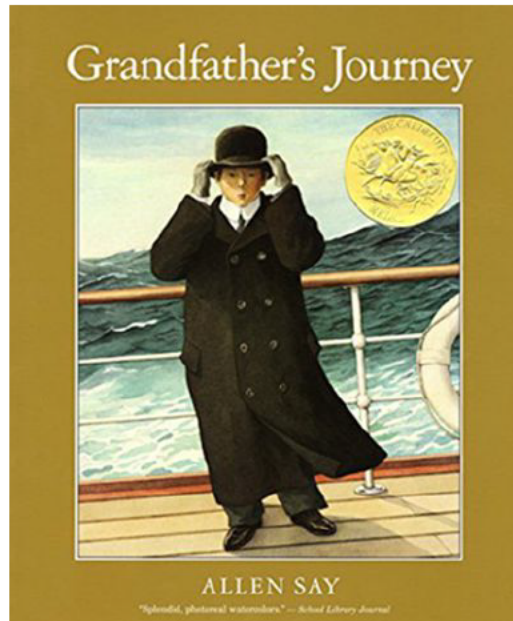

Keep going.

Work with your team. Questions 1-3: Circle **green check** or **red X**.  
Questions 4 and 5: Fill in the blanks.

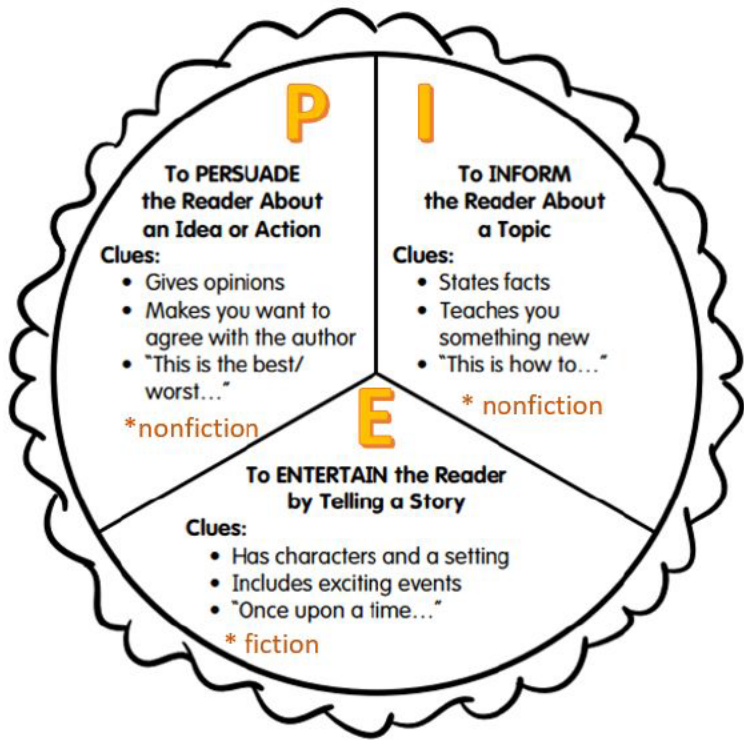

1. Is Allen Say **giving his opinion** or trying to **get us to agree with him**?



2. Is he **teaching** us something or sharing **facts** with us?



3. Is telling a story with **characters** and a **setting**?

4. Allen Say wrote *Tea with Milk* to \_\_\_\_\_ the reader.

5. I know because \_\_\_\_\_.

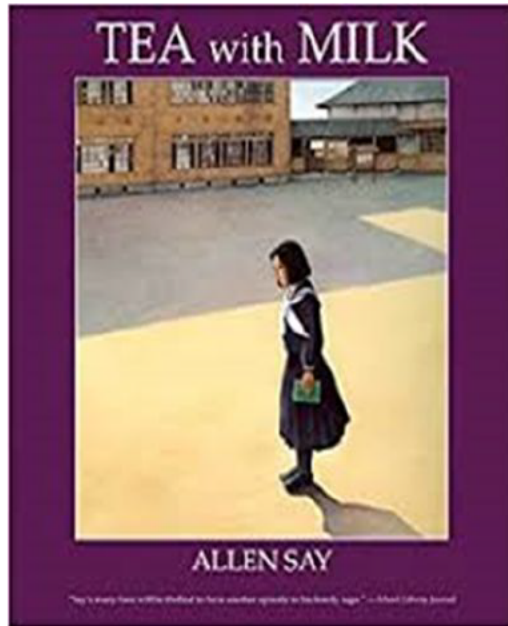

Try the next page for fun!

Work with your team to **make up a title** for each book based on the author's purpose.

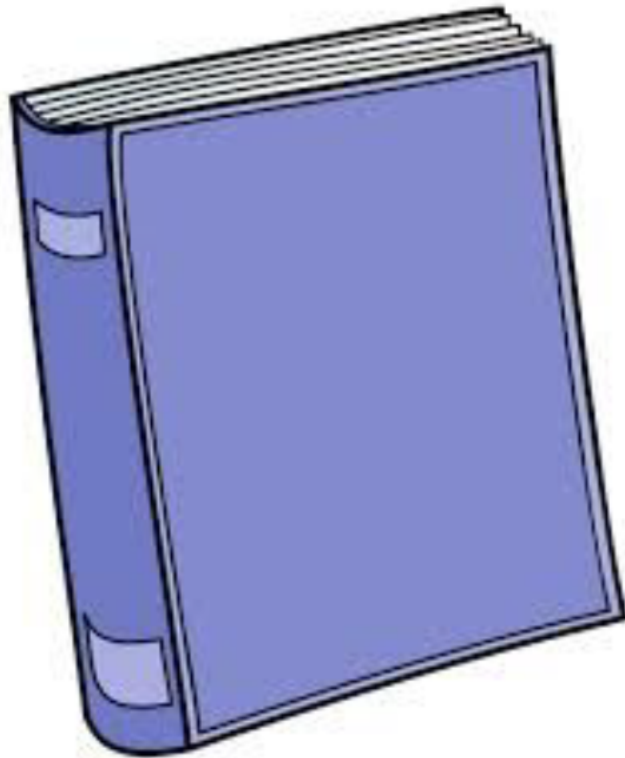

Author's purpose=persuade



Author's purpose=inform



Author's purpose=entertain



# How are the plots similar? Different?

## A Close Look

The different events that happen in a story make up the story's plot. When we are thinking about plot, it is helpful to ask "What happened first?" "What happened next?" and "What happened last?"

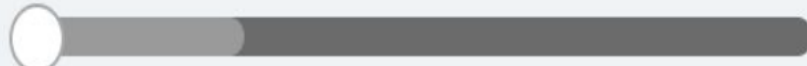

0:00 / 0:09

**plot:** what happens in a story; the sequence of events in a story





Grandfather's Journey



The Sign Painter



Tea with Milk

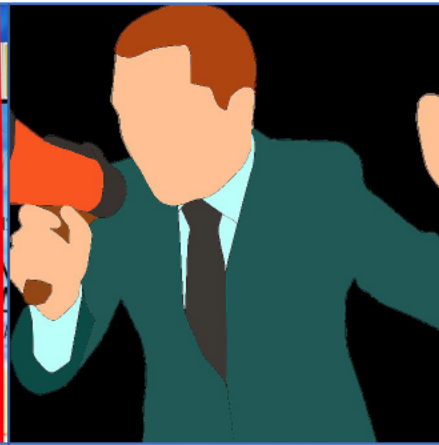

Inform

Persuad

Entertai

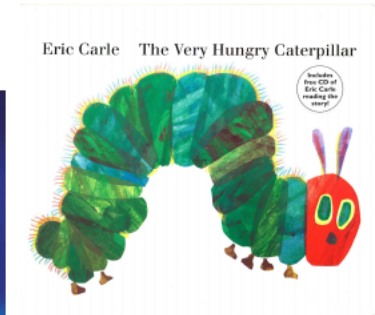
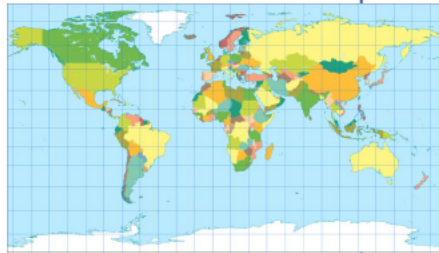

- +
  - How else can we  
help?

What else do you need to make the lessons more engaging for students?





1. Summary						
Attended participants	5					
Start time	2/10/22, 12:50:49 PM					
End time	2/10/22, 1:55:38 PM					
Meeting duration	1h 4m 49s					
Average attendance time	58m 18s					
2. Participants						
Name	First join	Last leave	In-meeting duration	Email	Participant ID (UPN)	Role
Erin Connor	2/10/22, 12:50:57 PM	2/10/22, 1:55:38 PM	1h 4m 41s	econnor@agora.org	econnor@agora.org	Presenter
Kristen Moore	2/10/22, 12:51:39 PM	2/10/22, 1:54:43 PM	1h 3m 3s	kmoore@agora.org	kmoore@agora.org	Presenter
Michelle Cukauskas	2/10/22, 12:58:57 PM	2/10/22, 1:54:43 PM	55m 45s	mcukauskas@agora.org	mcukauskas@agora.org	Organizer
Kristine Lorcheim	2/10/22, 1:00:52 PM	2/10/22, 1:54:44 PM	53m 51s	klorcheim@agora.org	klorcheim@agora.org	Presenter
Laurie Super	2/10/22, 1:01:26 PM	2/10/22, 1:55:37 PM	54m 10s	lsuper@agora.org	lsuper@agora.org	Presenter
3. In-Meeting activities						
Name	Join time	Leave time	Duration	Email	Role	
Erin Connor	2/10/22, 12:50:57 PM	2/10/22, 1:55:38 PM	1h 4m 41s	econnor@agora.org	Presenter	
Kristen Moore	2/10/22, 12:51:39 PM	2/10/22, 1:54:43 PM	1h 3m 3s	kmoore@agora.org	Presenter	
Michelle Cukauskas	2/10/22, 12:58:57 PM	2/10/22, 1:54:43 PM	55m 45s	mcukauskas@agora.org	Organizer	
Kristine Lorcheim	2/10/22, 1:00:52 PM	2/10/22, 1:54:44 PM	53m 51s	klorcheim@agora.org	Presenter	
Laurie Super	2/10/22, 1:01:26 PM	2/10/22, 1:55:37 PM	54m 10s	lsuper@agora.org	Presenter	

## 9/22/20 TeachTown Social Skills

### Agenda

- Introduction to the program
- Creating Accounts
- Assigning Students
- Implementation of program
- Assigning content to students
- Reports

## 9/22/20 TeachTown Social Skills Vendor Training

### Attendees:

Amber Staley  
Anna Lepsch  
Ashley Farster  
Ashley Schmidt  
Brett Stevens  
Brianna Pontious  
Janelle Shaffer  
Jen Lucia  
Jennifer Beeken  
Jennifer DePietro  
Jesse Capitano  
Kim Fiscus  
Laurie Super  
Maryann Johnson  
Renee Perri  
Colleen Freyvogel Bruss  
Michelle Cukauskas

# TODAY, WE WILL

- ◆ **Talk about our common goal, OUR WHY**
- ◆ **Highlight Current Legal Information**
- ◆ **How to ensure meaningful progress**
- ◆ **Show what you know**
- ◆ **Answer questions**



1225280\_MS. ERINN SLACKTISH\_AGORA TEACHER

AGORA ADMIN (Moderator)  
Cukauskas Karla Beadle (Participant)  
Freyvogel\_Amy Raught (Participant)  
Cukauskas\_Crysta Ganter (Participant)  
Schall\_JoDeen Buckwalter (Participant)  
Freyvogel\_Brett Stevens (Participant)  
Johnson\_Cathryn Mack (Participant)  
Freyvogel Bruss\_Tracey Ambuka (Participant)  
Freyvogel\_Amanda Armstrong (Participant)  
Cukauskas\_Jen Buss (Participant)  
Johnson Heidi Dodge (Participant)  
Kozar\_John Thomas (Participant)  
Schall\_Barb Cooper (Participant)  
Freyvogel\_Melissa McCracken (Participant)  
Cukauskas\_Erikka\_Henretta (Participant)  
Cukauskas\_Cathrine Hartman (Participant)  
Schall\_Terri Hunkele 2 (Participant)  
Johnson\_Kristina Lapsker (Participant)  
Johnson\_Dana O'Donnell (Participant)  
Johnson\_Michelle Pelissier (Participant)  
Schall\_Sasha Young (Participant)  
Dieter\_Jennifer McGinty (Participant)  
Freyvogel\_Allison Large (Participant)  
Freyvogel\_Shannon Hoffmaster (Participant)  
Cukauskas\_Christen Widdop (Participant)  
Freyvogel Bruss\_Jill Dunlap (Participant)  
Cukauskas\_Gina Mallon (Participant)  
Anne Dieter (Participant)  
Johnson\_Sarah Pittman (Participant)  
Fisher\_Cukauskas\_Michelle (Participant)  
Slacktish\_Dani Pricer (Participant)  
Freyvogel Bruss\_Lisa Brestensky (Participant)  
Schall\_Katie O'Donnell (Participant)  
Jen Fisher (Moderator)  
Dieter\_Brittany Kieffer (Participant)  
Natale\_Judy Deemer (Participant)  
Johnson\_Brittney Cantwell (Participant)  
Freyvogel\_Nicole Krol (Participant)  
Cukauskas\_Melanie Stanforth (Participant)  
Schall\_Gemma Mattox (Participant)  
Johnson\_Leslie Spratt (Participant)  
Freyvogel\_Amber Staley (Participant)  
Schall\_Tara Walker (Participant)  
Schall\_Jill Moyer (Participant)  
Cukauskas\_Heather Haney-Filippone (Participant)  
Cukauskas\_Ashley Schmidt (Participant)  
Joe Passante (Participant)  
Fisher\_Maryann Johnson (Participant)  
Schall\_Mandi Moyer (Participant)  
Freyvogel Bruss\_Jennifer Beeken (Participant)  
Jen Lucia (Moderator)

Freyvogel Bruss\_Carly Kirchner (Participant)  
Lucia\_Jessica Reese (Participant)  
Cukauskas\_Laurie Super (Participant)  
Cukauskas\_Ashley Farster (Participant)  
Lucia\_Ashley Malec (Participant)  
Johnson\_David Furka (Participant)  
Johnson\_Anna Lepsch (Participant)  
Freyvogel\_Heather\_Cobert (Participant)  
Natale\_Serena Costello (Participant)  
Schall\_Justine Fecik (Participant)  
Valerie Natale (Participant)  
Schall\_Michelle Olsavsky (Participant)  
Natale\_Melissa Stump (Participant)  
Freyvogel\_Lauren Radico (Participant)  
Schall\_Carissa Emrick (Participant)  
Johnson\_Kim Paolino (Participant)  
Lamison\_Natale (Participant)  
Freyvogel\_Kim Fiscus (Participant)



# T4-Agora Cyber Charter-Basics Training Webinar w.Kristina

Created by: sinnes@jigsawlearning.com · Your response: ✓Yes, I'm going

## Time

1pm - 4pm (Eastern Time - New York)

## Date

Mon Aug 31, 2020

## Description

T4-Agora Cyber Charter-PA Basics Training  
Webinar w.Kristina  
Mon, Aug 31, 2020 1:00 PM - 4:00 PM (EDT)  
55 student licenses expire 8/31/2021  
Maryann is Agoras tt admin

1.5 hours each of Basics and enCORE

Please join my meeting from your computer, tablet or smartphone. If the link is not accessible please copy and paste into any web browser.

<https://global.gotomeeting.com/join/276964709>

Please dial into the conference portion of the webinar using the Phone Number and Access Code provided below:

United States: +1 (669) 224-3412

Access Code: 276-964-709

Join from a video-conferencing room or system.  
Dial in or type: 67.217.95.2 or [inroomlink.goto.com](https://inroomlink.goto.com)  
Meeting ID: 276 964 709  
Or dial directly: 276964709@67.217.95.2 or  
67.217.95.2##276964709

## Guests

- ✓ [alanglais@teachtown.com](mailto:alanglais@teachtown.com)
- ✓ [aphillips@teachtown.com](mailto:aphillips@teachtown.com)
- ✓ Brett Stevens
- ✓ Chelsey Panchura
- ✓ Jesse Capitano
- ✓ Jen Lucia
- ✓ Laurie Super
- ✓ MARYANN JOHNSON
- ✓ MICHELLE CUKAUSKAS
- ✓ NICOLE KROL
- ✓ [pd@jigsawlearning.com](mailto:pd@jigsawlearning.com)
- ✓ Renee Perri
- ☉ Melissa Hale-Patterson
- Ashley Farster
- ANNA LEPSCH
- ASHLEY SCHMIDT
- Amber Staley
- Brianna Pontious
- CATHRYN MACK
- David Furka
- Dana O'Donnell
- Heather Cobert
- Jennifer Beeken
- Jennifer Cadieux
- JANELLE SHAFFER
- Kelly Berstecher
- [kcracknell@teachtown.com](mailto:kcracknell@teachtown.com)
- KIMBERLY FISCUS

New to GoToMeeting? Get the app now and be ready when your first meeting starts:  
<https://global.gotomeeting.com/install/276964709>

## AGENDA

1.5 hours - Basics - Introduction, Program Implementation, Adding Facilitators, Report Running, Goal Setting

1.5 hours - enCORE - Introduction, Standards Alignment, Implementation, Basics Alignment

My Notes



# AGENDA

---

Brief Overview of what is a PBSP

Procedure for Case Managers

- Review

- What's New

- Revisions

- Reminders

Summary

Q&A



## 1. Summary

Attended participants 137  
Start time "8/24/21, 2:22:06 PM"  
End time "8/24/21, 3:49:54 PM"  
Meeting duration 1h 27m 48s  
Average attendance time 31m 22s

## 2. Participants

Name	First join	Last leave	In-meeting duration	Email	Participant ID (UPN)	Role
Cathryn Mack	"8/24/21, 2:22:59 PM"	"8/24/21, 3:28:17 PM"	1h 5m 18s	cmack@agora.org	cmack@agora.org	Presenter
Kristal Costanzo	"8/24/21, 2:34:07 PM"	"8/24/21, 3:28:30 PM"	34m 54s	kcostanzo@agora.org	kcostanzo@agora.org	Presenter
Maura Basso	"8/24/21, 2:37:13 PM"	"8/24/21, 3:33:32 PM"	55m 7s	mbasso@agora.org	mbasso@agora.org	Presenter
Bridget Ellis	"8/24/21, 2:45:18 PM"	"8/24/21, 3:28:17 PM"	42m 58s	bellis@agora.org	bellis@agora.org	Presenter
Jessica Linderman	"8/24/21, 2:46:29 PM"	"8/24/21, 3:28:34 PM"	42m 4s	jlinderman@agora.org	jlinderman@agora.org	Presenter
Colien Byers	"8/24/21, 2:47:11 PM"	"8/24/21, 3:28:18 PM"	41m 7s	cbyers@agora.org	cbyers@agora.org	Presenter
Joy Fegely	"8/24/21, 2:47:18 PM"	"8/24/21, 3:28:20 PM"	41m 1s	jfegely@agora.org	jfegely@agora.org	Presenter
Barb Cooper	"8/24/21, 2:47:23 PM"	"8/24/21, 3:32:50 PM"	45m 27s	bcooper@agora.org	bcooper@agora.org	Presenter
Amanda Moyer	"8/24/21, 2:47:34 PM"	"8/24/21, 3:28:48 PM"	41m 14s	amoyer@agora.org	amoyer@agora.org	Presenter
Melissa Love	"8/24/21, 2:47:36 PM"	"8/24/21, 3:28:18 PM"	40m 42s	mlove@agora.org	mlove@agora.org	Presenter
Kattreena Amodeo	"8/24/21, 2:47:36 PM"	"8/24/21, 3:28:29 PM"	40m 52s	kamodeo@agora.org	kamodeo@agora.org	Presenter
Terri Hunkele	"8/24/21, 2:47:40 PM"	"8/24/21, 3:28:23 PM"	40m 43s	thunkele@agora.org	thunkele@agora.org	Presenter
Susan Lelko	"8/24/21, 2:47:42 PM"	"8/24/21, 3:28:34 PM"	40m 51s	slelko@agora.org	slelko@agora.org	Presenter
Breanne Scears	"8/24/21, 2:47:43 PM"	"8/24/21, 3:28:09 PM"	40m 25s	bscears@agora.org	bscears@agora.org	Presenter
Lisa Savitz	"8/24/21, 2:47:52 PM"	"8/24/21, 3:28:32 PM"	40m 39s	lsavitz@agora.org	lsavitz@agora.org	Presenter
Shannon Feeney Hoffmaster	"8/24/21, 2:48:00 PM"	"8/24/21, 3:28:29 PM"	40m 29s	shoffmaster@agora.org	shoffmaster@agora.org	Presenter
Amanda Armstrong	"8/24/21, 2:48:10 PM"	"8/24/21, 3:28:24 PM"	40m 14s	aarmstrong@agora.org	aarmstrong@agora.org	Presenter
Heather Silberman	"8/24/21, 2:48:34 PM"	"8/24/21, 3:28:29 PM"	39m 55s	hsilberman@agora.org	hsilberman@agora.org	Presenter
Amy Raught	"8/24/21, 2:49:01 PM"	"8/24/21, 3:28:21 PM"	39m 20s	araught@agora.org	araught@agora.org	Presenter
Tracey Ambuka	"8/24/21, 2:49:43 PM"	"8/24/21, 3:33:24 PM"	43m 40s	tambuka@agora.org	tambuka@agora.org	Presenter
Jesse Capitano	"8/24/21, 2:50:04 PM"	"8/24/21, 3:28:24 PM"	38m 20s	jcapitano@agora.org	jcapitano@agora.org	Presenter
Leslie Spratt	"8/24/21, 2:50:35 PM"	"8/24/21, 3:28:20 PM"	37m 44s	lspratt@agora.org	lspratt@agora.org	Presenter
Carmen Riggle	"8/24/21, 2:50:48 PM"	"8/24/21, 3:28:08 PM"	37m 19s	criggle@agora.org	criggle@agora.org	Presenter
Chris Baker	"8/24/21, 2:51:48 PM"	"8/24/21, 3:28:22 PM"	36m 33s	cbaker@agora.org	cbaker@agora.org	

cbaker@agora.org Presenter  
 Allison Large "8/24/21, 2:51:59 PM" "8/24/21, 3:28:23 PM" 36m 23s alarge@agora.org  
 alarge@agora.org Presenter  
 Nancy Reimers "8/24/21, 2:52:22 PM" "8/24/21, 3:28:25 PM" 36m 3s nreimers@agora.org  
 nreimers@agora.org Presenter  
 Marlee Atwood "8/24/21, 2:52:22 PM" "8/24/21, 3:28:21 PM" 35m 58s matwood@agora.org  
 matwood@agora.org Presenter  
 Jessica Barnhart "8/24/21, 2:52:37 PM" "8/24/21, 3:28:19 PM" 35m 41s jbarnhart@agora.org  
 jbarnhart@agora.org Presenter  
 Tamara Kozak "8/24/21, 2:52:43 PM" "8/24/21, 3:28:51 PM" 36m 8s tkozak@agora.org  
 tkozak@agora.org Presenter  
 Theresa Bash "8/24/21, 2:53:00 PM" "8/24/21, 3:28:18 PM" 35m 18s tbash@agora.org  
 tbash@agora.org Presenter  
 Jennifer Cadieux "8/24/21, 2:53:03 PM" "8/24/21, 3:28:31 PM" 35m 27s jcadieux@agora.org  
 jcadieux@agora.org Presenter  
 Brittany Froehlich "8/24/21, 2:53:22 PM" "8/24/21, 3:28:48 PM" 35m 26s BFroehlich@agora.org  
 BFroehlich@agora.org Presenter  
 Jennifer Flatley "8/24/21, 2:54:00 PM" "8/24/21, 3:32:14 PM" 38m 13s jflatley@agora.org  
 jflatley@agora.org Presenter  
 Molly Garczynski "8/24/21, 2:54:18 PM" "8/24/21, 3:28:24 PM" 34m 5s mgarczynski@agora.org  
 mgarczynski@agora.org Presenter  
 Cathrine Hartman "8/24/21, 2:54:39 PM" "8/24/21, 3:28:17 PM" 33m 38s chartman@agora.org  
 chartman@agora.org Presenter  
 Janet Ulewicz "8/24/21, 2:54:44 PM" "8/24/21, 3:28:21 PM" 33m 37s julewicz@agora.org  
 julewicz@agora.org Presenter  
 Michelle Pelissier "8/24/21, 2:54:47 PM" "8/24/21, 3:28:18 PM" 33m 31s mpelissier@agora.org  
 mpelissier@agora.org Presenter  
 Jodeen Buckwalter "8/24/21, 2:54:48 PM" "8/24/21, 3:28:19 PM" 33m 30s jbuckwalter@agora.org  
 jbuckwalter@agora.org Presenter  
 Susan Lipiec "8/24/21, 2:54:53 PM" "8/24/21, 3:28:40 PM" 33m 46s slipiec@agora.org  
 slipiec@agora.org Presenter  
 Melissa McCracken "8/24/21, 2:54:55 PM" "8/24/21, 3:28:27 PM" 33m 31s mmccracken@agora.org  
 mmccracken@agora.org Presenter  
 Maryann Johnson "8/24/21, 2:55:02 PM" "8/24/21, 3:32:40 PM" 37m 38s majohnson@agora.org  
 majohnson@agora.org Organizer  
 Theresa Draeger "8/24/21, 2:55:09 PM" "8/24/21, 3:49:54 PM" 54m 44s tdraeger@agora.org  
 tdraeger@agora.org Presenter  
 Melanie Stanforth "8/24/21, 2:55:12 PM" "8/24/21, 3:28:21 PM" 33m 8s mstanforth@agora.org  
 mstanforth@agora.org Presenter  
 Regina Kubica "8/24/21, 2:55:18 PM" "8/24/21, 3:28:01 PM" 32m 42s rkubica@agora.org  
 rkubica@agora.org Presenter  
 Kristina Lapsker "8/24/21, 2:55:23 PM" "8/24/21, 3:28:22 PM" 32m 58s klapsker@agora.org  
 klapsker@agora.org Presenter  
 Nicole Krol "8/24/21, 2:55:25 PM" "8/24/21, 3:24:33 PM" 29m 8s nkrol@agora.org nkrol@agora.org  
 Presenter  
 Jen Lucia "8/24/21, 2:55:37 PM" "8/24/21, 3:32:35 PM" 36m 57s jlucia@agora.org  
 jlucia@agora.org Presenter  
 Crystal Long "8/24/21, 2:55:41 PM" "8/24/21, 3:28:18 PM" 32m 36s clong@agora.org clong@agora.org  
 Presenter  
 Sabrina Kennedy "8/24/21, 2:55:46 PM" "8/24/21, 3:28:16 PM" 32m 30s skennedy@agora.org  
 skennedy@agora.org Presenter  
 Lisa Brestensky "8/24/21, 2:55:54 PM" "8/24/21, 3:28:44 PM" 32m 49s lbrestensky@agora.org  
 lbrestensky@agora.org Presenter  
 Brianna Pontious "8/24/21, 2:55:55 PM" "8/24/21, 3:28:25 PM" 32m 30s bpontious@agora.org  
 bpontious@agora.org Presenter  
 Brittany Reamer "8/24/21, 2:55:59 PM" "8/24/21, 3:28:15 PM" 32m 16s breamer@agora.org  
 breamer@agora.org Presenter

Michelle Olsavsky "8/24/21, 2:56:00 PM" "8/24/21, 3:28:22 PM" 32m 22s molsavsky@agora.org  
molsavsky@agora.org Presenter  
Casey Chaffin "8/24/21, 2:56:08 PM" "8/24/21, 3:28:27 PM" 32m 18s cchaffin@agora.org  
cchaffin@agora.org Presenter  
Jill Moyer "8/24/21, 2:56:09 PM" "8/24/21, 3:28:22 PM" 32m 13s jmoyer2@agora.org  
jmoyer2@agora.org Presenter  
Lauren Kerns "8/24/21, 2:56:09 PM" "8/24/21, 3:28:28 PM" 32m 18s lkerns@agora.org  
lkerns@agora.org Presenter  
Jennifer Buss "8/24/21, 2:56:19 PM" "8/24/21, 3:28:27 PM" 32m 7s jbus@agora.org jbus@agora.org  
Presenter  
Katie O'Donnell "8/24/21, 2:56:21 PM" "8/24/21, 3:28:19 PM" 31m 57s kodonnell@agora.org  
kodonnell@agora.org Presenter  
"Anne Butler, Ed.D" "8/24/21, 2:56:35 PM" "8/24/21, 3:05:10 PM" 8m 35s abutler@agora.org  
abutler@agora.org Presenter  
Serena Adams "8/24/21, 2:56:36 PM" "8/24/21, 3:28:13 PM" 31m 37s sadams@agora.org  
sadams@agora.org Presenter  
Samantha Bonniger "8/24/21, 2:56:44 PM" "8/24/21, 3:28:24 PM" 31m 40s sbonniger@agora.org  
sbonniger@agora.org Presenter  
Jill Severino "8/24/21, 2:56:49 PM" "8/24/21, 3:28:42 PM" 31m 53s jseverino@agora.org  
jseverino@agora.org Presenter  
Jennifer Zollman "8/24/21, 2:56:51 PM" "8/24/21, 3:28:20 PM" 31m 28s jzollman@agora.org  
jzollman@agora.org Presenter  
Brittney Walczak "8/24/21, 2:56:54 PM" "8/24/21, 3:28:07 PM" 31m 12s bwalczak@agora.org  
bwalczak@agora.org Presenter  
Ashley Farster "8/24/21, 2:56:57 PM" "8/24/21, 3:28:25 PM" 31m 27s afarster@agora.org  
afarster@agora.org Presenter  
Laura Stapf "8/24/21, 2:57:01 PM" "8/24/21, 3:28:19 PM" 31m 18s lstapf@agora.org  
lstapf@agora.org Presenter  
Shari Widlund "8/24/21, 2:57:07 PM" "8/24/21, 3:28:23 PM" 31m 15s swidlund@agora.org  
swidlund@agora.org Presenter  
Kelly Berstecher "8/24/21, 2:57:08 PM" "8/24/21, 3:28:19 PM" 31m 11s kberstecher@agora.org  
kberstecher@agora.org Presenter  
Jena Huffman "8/24/21, 2:57:12 PM" "8/24/21, 3:32:22 PM" 35m 9s jhuffman@agora.org  
jhuffman@agora.org Presenter  
Jenna Lee Dietrich "8/24/21, 2:57:19 PM" "8/24/21, 3:28:26 PM" 31m 7s jdietrich@agora.org  
jdietrich@agora.org Presenter  
Dana O'Donnell "8/24/21, 2:57:31 PM" "8/24/21, 3:28:30 PM" 30m 58s Dodonnell@agora.org  
Dodonnell@agora.org Presenter  
Lauren Svonavec "8/24/21, 2:57:34 PM" "8/24/21, 3:28:18 PM" 30m 44s lsvonavec@agora.org  
lsvonavec@agora.org Presenter  
Judy Deemer "8/24/21, 2:57:38 PM" "8/24/21, 3:28:21 PM" 30m 42s jdeemer@agora.org  
jdeemer@agora.org Presenter  
Rachel Carmichael "8/24/21, 2:57:41 PM" "8/24/21, 3:28:25 PM" 30m 43s rcarmichael@agora.org  
rcarmichael@agora.org Presenter  
Melissa Gaso "8/24/21, 2:57:48 PM" "8/24/21, 3:28:35 PM" 30m 47s mgaso@agora.org  
mgaso@agora.org Presenter  
Maria Harlan "8/24/21, 2:57:57 PM" "8/24/21, 3:28:19 PM" 30m 22s mharlan@agora.org  
mharlan@agora.org Presenter  
Gillian Kaufman "8/24/21, 2:57:58 PM" "8/24/21, 3:28:30 PM" 30m 32s gkaufman@agora.org  
gkaufman@agora.org Presenter  
David Furka "8/24/21, 2:58:00 PM" "8/24/21, 3:28:28 PM" 30m 27s dfurka@agora.org  
dfurka@agora.org Presenter  
Regina Mallon "8/24/21, 2:58:04 PM" "8/24/21, 3:28:22 PM" 30m 18s gmallon@agora.org  
gmallon@agora.org Presenter  
Jennifer McGinty "8/24/21, 2:58:06 PM" "8/24/21, 3:28:24 PM" 30m 17s jmcginty@agora.org  
jmcginty@agora.org Presenter  
Jennifer Beeken "8/24/21, 2:58:07 PM" "8/24/21, 3:28:33 PM" 30m 26s jbeeken@agora.org

jbeeken@agora.org Presenter  
 Carissa Emrick "8/24/21, 2:58:16 PM""8/24/21, 3:28:26 PM"30m 10s cemrick@agora.org  
 cemrick@agora.org Presenter  
 Amanda Kammermeier "8/24/21, 2:58:27 PM""8/24/21, 3:28:18 PM"29m 50s  
 akammermeier@agora.org akammermeier@agora.org Presenter  
 Amber Staley "8/24/21, 2:58:27 PM""8/24/21, 3:28:19 PM"29m 51s astaley2@agora.org  
 astaley2@agora.org Presenter  
 Tara Walker "8/24/21, 2:58:32 PM""8/24/21, 3:28:14 PM"29m 41s twalker@agora.org  
 twalker@agora.org Presenter  
 Rachel Weeks "8/24/21, 2:59:02 PM""8/24/21, 3:28:20 PM"29m 18s rweeks@agora.org  
 rweeks@agora.org Presenter  
 Veronica Jackson "8/24/21, 2:59:11 PM""8/24/21, 3:28:32 PM"29m 20s vjackson@agora.org  
 vjackson@agora.org Presenter  
 Lauren Lamison "8/24/21, 2:59:11 PM""8/24/21, 3:28:17 PM"29m 5s llamison@agora.org  
 llamison@agora.org Presenter  
 Kimberly Paolino "8/24/21, 2:59:14 PM""8/24/21, 3:28:18 PM"29m 3s kpaolino@agora.org  
 kpaolino@agora.org Presenter  
 Cathryn Ramsey "8/24/21, 2:59:35 PM""8/24/21, 3:28:28 PM"28m 52s cramsey@agora.org  
 cramsey@agora.org Presenter  
 Brittney Cantwell "8/24/21, 2:59:36 PM""8/24/21, 3:28:30 PM"28m 54s bcantwell@agora.org  
 bcantwell@agora.org Presenter  
 Christen Widdop "8/24/21, 2:59:37 PM""8/24/21, 3:28:21 PM"28m 44s cwiddop@agora.org  
 cwiddop@agora.org Presenter  
 Anna Lepsch "8/24/21, 2:59:43 PM""8/24/21, 3:28:32 PM"28m 49s alepsch@agora.org  
 alepsch@agora.org Presenter  
 Melissa Hale-Patterson "8/24/21, 2:59:43 PM""8/24/21, 3:28:50 PM"29m 7s mpatterson@agora.org  
 mpatterson@agora.org Presenter  
 Rebekah Congdon "8/24/21, 2:59:43 PM""8/24/21, 3:28:16 PM"28m 33s rcongdon@agora.org  
 rcongdon@agora.org Presenter  
 Sarah Pittman "8/24/21, 2:59:44 PM""8/24/21, 3:28:56 PM"16m 34s spittman@agora.org  
 spittman@agora.org Presenter  
 Anna Baranoski "8/24/21, 2:59:51 PM""8/24/21, 3:28:20 PM"28m 28s abaranoski@agora.org  
 abaranoski@agora.org Presenter  
 Shelley Stump "8/24/21, 2:59:55 PM""8/24/21, 3:32:08 PM"32m 12s sstump@agora.org  
 sstump@agora.org Presenter  
 Stacy Vietmeier "8/24/21, 2:59:59 PM""8/24/21, 3:28:29 PM"28m 29s svietmeier@agora.org  
 svietmeier@agora.org Presenter  
 Melissa Stump "8/24/21, 3:00:01 PM""8/24/21, 3:28:17 PM"28m 16s mstump@agora.org  
 mstump@agora.org Presenter  
 Amber Brisbane "8/24/21, 3:00:01 PM""8/24/21, 3:28:18 PM"28m 16s abrisbane@agora.org  
 abrisbane@agora.org Presenter  
 Angela Denham "8/24/21, 3:00:02 PM""8/24/21, 3:28:19 PM"28m 16s adenham@agora.org  
 adenham@agora.org Presenter  
 Gemma Mattox "8/24/21, 3:00:04 PM""8/24/21, 3:28:25 PM"28m 20s gmattox@agora.org  
 gmattox@agora.org Presenter  
 John Thomas "8/24/21, 3:00:08 PM""8/24/21, 3:28:11 PM"28m 2s jthomas@agora.org  
 jthomas@agora.org Presenter  
 Jennifer DePietro "8/24/21, 3:00:09 PM""8/24/21, 3:28:27 PM"28m 18s jdepietro@agora.org  
 jdepietro@agora.org Presenter  
 Danielle Pricer "8/24/21, 3:00:18 PM""8/24/21, 3:28:38 PM"28m 20s dpricer@agora.org  
 dpricer@agora.org Presenter  
 Stefanie Marcello "8/24/21, 3:00:32 PM""8/24/21, 3:29:28 PM"28m 56s smarcello@agora.org  
 smarcello@agora.org Presenter  
 Cortney Barkley "8/24/21, 3:00:34 PM""8/24/21, 3:28:18 PM"27m 44s cbarkley@agora.org  
 cbarkley@agora.org Presenter  
 Brett Stevens "8/24/21, 3:00:34 PM""8/24/21, 3:28:17 PM"27m 43s bstevens2@agora.org  
 bstevens2@agora.org Presenter

Melissa Franklin "8/24/21, 3:00:42 PM""8/24/21, 3:29:28 PM"28m 46s mfranklin@agora.org  
mfranklin@agora.org Presenter  
Kristy Welsh "8/24/21, 3:00:51 PM""8/24/21, 3:25:13 PM"24m 22s kwelsh@agora.org  
kwelsh@agora.org Presenter  
Lynn Pagliei "8/24/21, 3:00:54 PM""8/24/21, 3:28:14 PM"27m 20s lpagliei@agora.org  
lpagliei@agora.org Presenter  
Renee Perri "8/24/21, 3:00:58 PM""8/24/21, 3:28:16 PM"27m 17s rperri@agora.org  
rperri@agora.org Presenter  
Gina Rodriguez "8/24/21, 3:01:04 PM""8/24/21, 3:28:22 PM"27m 17s grodriguez@agora.org  
grodriguez@agora.org Presenter  
Dana Pacolay "8/24/21, 3:01:23 PM""8/24/21, 3:28:48 PM"27m 25s dpacolay@agora.org  
dpacolay@agora.org Presenter  
Chelsey Panchura "8/24/21, 3:01:29 PM""8/24/21, 3:28:42 PM"27m 13s cpanchura@agora.org  
cpanchura@agora.org Presenter  
Kymberly Humanick "8/24/21, 3:01:31 PM""8/24/21, 3:28:23 PM"26m 51s khumanick@agora.org  
khumanick@agora.org Presenter  
Valerie Natale "8/24/21, 3:01:41 PM""8/24/21, 3:29:17 PM"27m 36s vnatale@agora.org  
vnatale@agora.org Presenter  
Patrick Lavelle "8/24/21, 3:01:48 PM""8/24/21, 3:28:20 PM"26m 32s plavelle@agora.org  
plavelle@agora.org Presenter  
Janelle Shaffer "8/24/21, 3:01:48 PM""8/24/21, 3:28:20 PM"26m 32s jshaffer3@agora.org  
jshaffer3@agora.org Presenter  
Kaelyn Hoffman "8/24/21, 3:01:55 PM""8/24/21, 3:28:44 PM"26m 48s khoffman@agora.org  
khoffman@agora.org Presenter  
Heidi Dodge "8/24/21, 3:02:23 PM""8/24/21, 3:28:31 PM"26m 8s hdodge@agora.org  
hdodge@agora.org Presenter  
Erin Scrip "8/24/21, 3:02:24 PM""8/24/21, 3:34:19 PM"28m 42s escrip@agora.org escrip@agora.org  
Presenter  
Julie Doebereiner "8/24/21, 3:03:14 PM""8/24/21, 3:35:44 PM"32m 29s jdoebereiner@agora.org  
jdoebereiner@agora.org Presenter  
Olivia Eckels "8/24/21, 3:04:33 PM""8/24/21, 3:28:25 PM"23m 51s oeckels@agora.org  
oeckels@agora.org Presenter  
Danielle Schall "8/24/21, 3:04:57 PM""8/24/21, 3:28:26 PM"23m 28s dschall@agora.org  
dschall@agora.org Presenter  
Sasha Young "8/24/21, 3:05:09 PM""8/24/21, 3:28:21 PM"23m 11s syoung@agora.org  
syoung@agora.org Presenter  
Lauren Radico "8/24/21, 3:05:25 PM""8/24/21, 3:29:20 PM"23m 54s lradico@agora.org  
lradico@agora.org Presenter  
Heather Gallagher "8/24/21, 3:05:43 PM""8/24/21, 3:30:28 PM"24m 45s hgallagher@agora.org  
hgallagher@agora.org Presenter  
Erin Connor "8/24/21, 3:06:23 PM""8/24/21, 3:11:02 PM"4m 39s econnor@agora.org  
econnor@agora.org Presenter  
Whitney Bargerstock "8/24/21, 3:07:41 PM""8/24/21, 3:30:56 PM"23m 14s wbargerstock@agora.org  
wbargerstock@agora.org Presenter  
Kimberly Fiscus "8/24/21, 3:07:46 PM""8/24/21, 3:28:19 PM"20m 32s kfiscus@agora.org  
kfiscus@agora.org Presenter  
Colleen Freyvogel Bruss "8/24/21, 3:08:58 PM""8/24/21, 3:28:22 PM"19m 23s cfreyvogel@agora.org  
cfreyvogel@agora.org Presenter  
Mindy Wesley "8/24/21, 3:13:21 PM""8/24/21, 3:14:30 PM"1m 9s mwesley@agora.org  
mwesley@agora.org Presenter  
Christine Thomas "8/24/21, 3:15:15 PM""8/24/21, 3:28:24 PM"13m 8s cthomas@agora.org  
cthomas@agora.org Presenter  
Erinn Slacktish "8/24/21, 3:15:21 PM""8/24/21, 3:28:21 PM"13m eslacktish@agora.org  
eslacktish@agora.org Presenter  
Kimberly McLaughlin "8/24/21, 3:26:26 PM""8/24/21, 3:28:31 PM"2m 5s kmclaughlin@agora.org  
kmclaughlin@agora.org Presenter

### 3. In-Meeting activities

Name	Join time	Leave time	Duration	Email	Role
Cathryn Mack	"8/24/21, 2:22:59 PM"	"8/24/21, 3:28:17 PM"	1h 5m 18s	cmack@agora.org	Presenter
Kristal Costanzo	"8/24/21, 2:34:07 PM"	"8/24/21, 2:34:34 PM"	26s	kcostanzo@agora.org	Presenter
Kristal Costanzo	"8/24/21, 2:54:01 PM"	"8/24/21, 3:28:30 PM"	34m 28s	kcostanzo@agora.org	Presenter
Maura Basso	"8/24/21, 2:37:13 PM"	"8/24/21, 3:31:17 PM"	54m 4s	mbasso@agora.org	Presenter
Maura Basso	"8/24/21, 3:32:28 PM"	"8/24/21, 3:33:32 PM"	1m 3s	mbasso@agora.org	Presenter
Bridget Ellis	"8/24/21, 2:45:18 PM"	"8/24/21, 3:28:17 PM"	42m 58s	bellis@agora.org	Presenter
Jessica Linderman	"8/24/21, 2:46:29 PM"	"8/24/21, 3:28:34 PM"	42m 4s	jlinderman@agora.org	Presenter
Colien Byers	"8/24/21, 2:47:11 PM"	"8/24/21, 3:28:18 PM"	41m 7s	cbyers@agora.org	Presenter
Joy Fegely	"8/24/21, 2:47:18 PM"	"8/24/21, 3:28:20 PM"	41m 1s	jfegely@agora.org	Presenter
Barb Cooper	"8/24/21, 2:47:23 PM"	"8/24/21, 3:32:50 PM"	45m 27s	bcooper@agora.org	Presenter
Amanda Moyer	"8/24/21, 2:47:34 PM"	"8/24/21, 3:28:48 PM"	41m 14s	amoyer@agora.org	Presenter
Melissa Love	"8/24/21, 2:47:36 PM"	"8/24/21, 3:28:18 PM"	40m 42s	mlove@agora.org	Presenter
Kattreena Amodeo	"8/24/21, 2:47:36 PM"	"8/24/21, 3:28:29 PM"	40m 52s	kamodeo@agora.org	Presenter
Terri Hunkele	"8/24/21, 2:47:40 PM"	"8/24/21, 3:28:23 PM"	40m 43s	thunkele@agora.org	Presenter
Susan Lelko	"8/24/21, 2:47:42 PM"	"8/24/21, 3:28:34 PM"	40m 51s	slelko@agora.org	Presenter
Breanne Scears	"8/24/21, 2:47:43 PM"	"8/24/21, 3:28:09 PM"	40m 25s	bscears@agora.org	Presenter
Lisa Savitz	"8/24/21, 2:47:52 PM"	"8/24/21, 3:28:32 PM"	40m 39s	lsavitz@agora.org	Presenter
Shannon Feeney Hoffmaster	"8/24/21, 2:48:00 PM"	"8/24/21, 3:28:29 PM"	40m 29s	shoffmaster@agora.org	Presenter
Amanda Armstrong	"8/24/21, 2:48:10 PM"	"8/24/21, 3:28:24 PM"	40m 14s	aarmstrong@agora.org	Presenter
Heather Silberman	"8/24/21, 2:48:34 PM"	"8/24/21, 3:28:29 PM"	39m 55s	hsilberman@agora.org	Presenter
Amy Raught	"8/24/21, 2:49:01 PM"	"8/24/21, 3:28:21 PM"	39m 20s	araught@agora.org	Presenter
Tracey Ambuka	"8/24/21, 2:49:43 PM"	"8/24/21, 3:33:24 PM"	43m 40s	tambuka@agora.org	Presenter
Jesse Capitano	"8/24/21, 2:50:04 PM"	"8/24/21, 3:28:24 PM"	38m 20s	jcapitano@agora.org	Presenter
Leslie Spratt	"8/24/21, 2:50:35 PM"	"8/24/21, 3:28:20 PM"	37m 44s	lspratt@agora.org	Presenter
Carmen Riggle	"8/24/21, 2:50:48 PM"	"8/24/21, 3:28:08 PM"	37m 19s	criggle@agora.org	Presenter
Chris Baker	"8/24/21, 2:51:48 PM"	"8/24/21, 3:28:22 PM"	36m 33s	cbaker@agora.org	Presenter
Allison Large	"8/24/21, 2:51:59 PM"	"8/24/21, 3:28:23 PM"	36m 23s	alarge@agora.org	Presenter
Nancy Reimers	"8/24/21, 2:52:22 PM"	"8/24/21, 3:28:25 PM"	36m 3s	nreimers@agora.org	Presenter
Marlee Atwood	"8/24/21, 2:52:22 PM"	"8/24/21, 3:28:21 PM"	35m 58s	matwood@agora.org	Presenter
Jessica Barnhart	"8/24/21, 2:52:37 PM"	"8/24/21, 3:28:19 PM"	35m 41s	jbarnhart@agora.org	Presenter
Tamara Kozak	"8/24/21, 2:52:43 PM"	"8/24/21, 3:28:51 PM"	36m 8s	tkozak@agora.org	Presenter
Theresa Bash	"8/24/21, 2:53:00 PM"	"8/24/21, 3:28:18 PM"	35m 18s	tbash@agora.org	Presenter
Jennifer Cadieux	"8/24/21, 2:53:03 PM"	"8/24/21, 3:28:31 PM"	35m 27s	jcadieux@agora.org	Presenter
Brittany Froehlich	"8/24/21, 2:53:22 PM"	"8/24/21, 3:28:48 PM"	35m 26s	BFroehlich@agora.org	Presenter
Jennifer Flatley	"8/24/21, 2:54:00 PM"	"8/24/21, 3:32:14 PM"	38m 13s	jflatley@agora.org	Presenter
Molly Garczynski	"8/24/21, 2:54:18 PM"	"8/24/21, 3:28:24 PM"	34m 5s	mgarczynski@agora.org	Presenter
Cathrine Hartman	"8/24/21, 2:54:39 PM"	"8/24/21, 3:28:17 PM"	33m 38s	chartman@agora.org	Presenter
Janet Ulewicz	"8/24/21, 2:54:44 PM"	"8/24/21, 3:28:21 PM"	33m 37s	julewicz@agora.org	Presenter
Michelle Pelissier	"8/24/21, 2:54:47 PM"	"8/24/21, 3:28:18 PM"	33m 31s	mpelissier@agora.org	Presenter
Jodeen Buckwalter	"8/24/21, 2:54:48 PM"	"8/24/21, 3:28:19 PM"	33m 30s	jbuckwalter@agora.org	Presenter
Susan Lipiec	"8/24/21, 2:54:53 PM"	"8/24/21, 3:28:40 PM"	33m 46s	slipiec@agora.org	Presenter
Melissa McCracken	"8/24/21, 2:54:55 PM"	"8/24/21, 3:28:27 PM"	33m 31s	mmccracken@agora.org	Presenter
Maryann Johnson	"8/24/21, 2:55:02 PM"	"8/24/21, 3:32:40 PM"	37m 38s	majohnson@agora.org	Organizer
Theresa Draeger	"8/24/21, 2:55:09 PM"	"8/24/21, 3:49:54 PM"	54m 44s	tdraeger@agora.org	Presenter

Melanie Stanforth "8/24/21, 2:55:12 PM""8/24/21, 3:28:21 PM"33m 8s mstanforth@agora.org  
 Presenter  
 Regina Kubica "8/24/21, 2:55:18 PM""8/24/21, 3:28:01 PM"32m 42s rkubica@agora.org Presenter  
 Kristina Lapsker "8/24/21, 2:55:23 PM""8/24/21, 3:28:22 PM"32m 58s klapsker@agora.org Presenter  
 Nicole Krol "8/24/21, 2:55:25 PM""8/24/21, 3:24:33 PM"29m 8s nkrol@agora.org Presenter  
 Jen Lucia "8/24/21, 2:55:37 PM""8/24/21, 3:32:35 PM"36m 57s jlucia@agora.org Presenter  
 Crystal Long "8/24/21, 2:55:41 PM""8/24/21, 3:28:18 PM"32m 36s clong@agora.org Presenter  
 Sabrina Kennedy "8/24/21, 2:55:46 PM""8/24/21, 3:28:16 PM"32m 30s skennedy@agora.org Presenter  
 Lisa Brestensky "8/24/21, 2:55:54 PM""8/24/21, 3:28:44 PM"32m 49s lbrestensky@agora.org  
 Presenter  
 Brianna Pontious "8/24/21, 2:55:55 PM""8/24/21, 3:28:25 PM"32m 30s bpontious@agora.org Presenter  
 Brittany Reamer "8/24/21, 2:55:59 PM""8/24/21, 3:28:15 PM"32m 16s breamer@agora.org Presenter  
 Michelle Olsavsky "8/24/21, 2:56:00 PM""8/24/21, 3:28:22 PM"32m 22s molsavsky@agora.org  
 Presenter  
 Casey Chaffin "8/24/21, 2:56:08 PM""8/24/21, 3:28:27 PM"32m 18s cchaffin@agora.org Presenter  
 Jill Moyer "8/24/21, 2:56:09 PM""8/24/21, 3:28:22 PM"32m 13s jmoyer2@agora.org Presenter  
 Lauren Kerns "8/24/21, 2:56:09 PM""8/24/21, 3:28:28 PM"32m 18s lkerns@agora.org Presenter  
 Jennifer Buss "8/24/21, 2:56:19 PM""8/24/21, 3:28:27 PM"32m 7s jbus@agora.org Presenter  
 Katie O'Donnell "8/24/21, 2:56:21 PM""8/24/21, 3:28:19 PM"31m 57s kodonnell@agora.org Presenter  
 "Anne Butler, Ed.D" "8/24/21, 2:56:35 PM""8/24/21, 3:05:10 PM"8m 35s abutler@agora.org  
 Presenter  
 Serena Adams "8/24/21, 2:56:36 PM""8/24/21, 3:28:13 PM"31m 37s sadams@agora.org Presenter  
 Samantha Bonniger "8/24/21, 2:56:44 PM""8/24/21, 3:28:24 PM"31m 40s sbonniger@agora.org  
 Presenter  
 Jill Severino "8/24/21, 2:56:49 PM""8/24/21, 3:28:42 PM"31m 53s jseverino@agora.org Presenter  
 Jennifer Zollman "8/24/21, 2:56:51 PM""8/24/21, 3:28:20 PM"31m 28s jzollman@agora.org Presenter  
 Brittney Walczak "8/24/21, 2:56:54 PM""8/24/21, 3:28:07 PM"31m 12s bwalczak@agora.org Presenter  
 Ashley Farster "8/24/21, 2:56:57 PM""8/24/21, 3:28:25 PM"31m 27s afarster@agora.org Presenter  
 Laura Stapf "8/24/21, 2:57:01 PM""8/24/21, 3:28:19 PM"31m 18s lstapf@agora.org Presenter  
 Shari Widlund "8/24/21, 2:57:07 PM""8/24/21, 3:28:23 PM"31m 15s swidlund@agora.org Presenter  
 Kelly Berstecher "8/24/21, 2:57:08 PM""8/24/21, 3:28:19 PM"31m 11s kberstecher@agora.org  
 Presenter  
 Jena Huffman "8/24/21, 2:57:12 PM""8/24/21, 3:32:22 PM"35m 9s jhuffman@agora.org Presenter  
 Jenna Lee Dietrich "8/24/21, 2:57:19 PM""8/24/21, 3:28:26 PM"31m 7s jdietrich@agora.org  
 Presenter  
 Dana O'Donnell "8/24/21, 2:57:31 PM""8/24/21, 3:28:30 PM"30m 58s Dodonnell@agora.org Presenter  
 Lauren Svonavec "8/24/21, 2:57:34 PM""8/24/21, 3:28:18 PM"30m 44s lsvonavec@agora.org  
 Presenter  
 Judy Deemer "8/24/21, 2:57:38 PM""8/24/21, 3:28:21 PM"30m 42s jdeemer@agora.org Presenter  
 Rachel Carmichael "8/24/21, 2:57:41 PM""8/24/21, 3:28:25 PM"30m 43s rcarmichael@agora.org  
 Presenter  
 Melissa Gaso "8/24/21, 2:57:48 PM""8/24/21, 3:28:35 PM"30m 47s mgaso@agora.org Presenter  
 Maria Harlan "8/24/21, 2:57:57 PM""8/24/21, 3:28:19 PM"30m 22s mharlan@agora.org Presenter  
 Gillian Kaufman "8/24/21, 2:57:58 PM""8/24/21, 3:28:30 PM"30m 32s gkaufman@agora.org Presenter  
 David Furka "8/24/21, 2:58:00 PM""8/24/21, 3:28:28 PM"30m 27s dfurka@agora.org Presenter  
 Regina Mallon "8/24/21, 2:58:04 PM""8/24/21, 3:28:22 PM"30m 18s gmallon@agora.org Presenter  
 Jennifer McGinty "8/24/21, 2:58:06 PM""8/24/21, 3:28:24 PM"30m 17s jmcginty@agora.org Presenter  
 Jennifer Beeken "8/24/21, 2:58:07 PM""8/24/21, 3:28:33 PM"30m 26s jbeeken@agora.org Presenter  
 Carissa Emrick "8/24/21, 2:58:16 PM""8/24/21, 3:28:26 PM"30m 10s cemrick@agora.org Presenter  
 Amanda Kammermeier "8/24/21, 2:58:27 PM""8/24/21, 3:28:18 PM"29m 50s  
 akammermeier@agora.org Presenter  
 Amber Staley "8/24/21, 2:58:27 PM""8/24/21, 3:28:19 PM"29m 51s astaley2@agora.org Presenter  
 Tara Walker "8/24/21, 2:58:32 PM""8/24/21, 3:28:14 PM"29m 41s twalker@agora.org Presenter  
 Rachel Weeks "8/24/21, 2:59:02 PM""8/24/21, 3:28:20 PM"29m 18s rweeks@agora.org Presenter  
 Veronica Jackson "8/24/21, 2:59:11 PM""8/24/21, 3:28:32 PM"29m 20s vjackson@agora.org  
 Presenter  
 Lauren Lamison "8/24/21, 2:59:11 PM""8/24/21, 3:28:17 PM"29m 5s llamison@agora.org Presenter



Kimberly Paolino	"8/24/21, 2:59:14 PM"	"8/24/21, 3:28:18 PM"	29m 3s	kpaolino@agora.org	Presenter
Cathryn Ramsey	"8/24/21, 2:59:35 PM"	"8/24/21, 3:28:28 PM"	28m 52s	cramsey@agora.org	Presenter
Brittney Cantwell	"8/24/21, 2:59:36 PM"	"8/24/21, 3:28:30 PM"	28m 54s	bcantwell@agora.org	Presenter
Christen Widdop	"8/24/21, 2:59:37 PM"	"8/24/21, 3:28:21 PM"	28m 44s	cwiddop@agora.org	Presenter
Anna Lepsch	"8/24/21, 2:59:43 PM"	"8/24/21, 3:28:32 PM"	28m 49s	alepsch@agora.org	Presenter
Melissa Hale-Patterson	"8/24/21, 2:59:43 PM"	"8/24/21, 3:28:50 PM"	29m 7s	mpatterson@agora.org	Presenter
Rebekah Congdon	"8/24/21, 2:59:43 PM"	"8/24/21, 3:28:16 PM"	28m 33s	rcongdon@agora.org	Presenter
Sarah Pittman	"8/24/21, 2:59:44 PM"	"8/24/21, 3:15:59 PM"	16m 15s	spittman@agora.org	Presenter
Sarah Pittman	"8/24/21, 3:28:37 PM"	"8/24/21, 3:28:56 PM"	19s	spittman@agora.org	Presenter
Anna Baranoski	"8/24/21, 2:59:51 PM"	"8/24/21, 3:28:20 PM"	28m 28s	abaranoski@agora.org	Presenter
Shelley Stump	"8/24/21, 2:59:55 PM"	"8/24/21, 3:32:08 PM"	32m 12s	sstump@agora.org	Presenter
Stacy Vietmeier	"8/24/21, 2:59:59 PM"	"8/24/21, 3:28:29 PM"	28m 29s	svietmeier@agora.org	Presenter
Melissa Stump	"8/24/21, 3:00:01 PM"	"8/24/21, 3:28:17 PM"	28m 16s	mstump@agora.org	Presenter
Amber Brisbane	"8/24/21, 3:00:01 PM"	"8/24/21, 3:28:18 PM"	28m 16s	abrisbane@agora.org	Presenter
Angela Denham	"8/24/21, 3:00:02 PM"	"8/24/21, 3:28:19 PM"	28m 16s	adenham@agora.org	Presenter
Gemma Mattox	"8/24/21, 3:00:04 PM"	"8/24/21, 3:28:25 PM"	28m 20s	gmattox@agora.org	Presenter
John Thomas	"8/24/21, 3:00:08 PM"	"8/24/21, 3:28:11 PM"	28m 2s	jthomas@agora.org	Presenter
Jennifer DePietro	"8/24/21, 3:00:09 PM"	"8/24/21, 3:28:27 PM"	28m 18s	jdepietro@agora.org	Presenter
Danielle Pricer	"8/24/21, 3:00:18 PM"	"8/24/21, 3:28:38 PM"	28m 20s	dpricer@agora.org	Presenter
Stefanie Marcello	"8/24/21, 3:00:32 PM"	"8/24/21, 3:29:28 PM"	28m 56s	smarcello@agora.org	Presenter
Cortney Barkley	"8/24/21, 3:00:34 PM"	"8/24/21, 3:28:18 PM"	27m 44s	cbarkley@agora.org	Presenter
Brett Stevens	"8/24/21, 3:00:34 PM"	"8/24/21, 3:28:17 PM"	27m 43s	bstevens2@agora.org	Presenter
Melissa Franklin	"8/24/21, 3:00:42 PM"	"8/24/21, 3:29:28 PM"	28m 46s	mfranklin@agora.org	Presenter
Kristy Welsh	"8/24/21, 3:00:51 PM"	"8/24/21, 3:25:13 PM"	24m 22s	kwelsh@agora.org	Presenter
Lynn Pagliei	"8/24/21, 3:00:54 PM"	"8/24/21, 3:28:14 PM"	27m 20s	lpagliei@agora.org	Presenter
Renee Perri	"8/24/21, 3:00:58 PM"	"8/24/21, 3:28:16 PM"	27m 17s	rperri@agora.org	Presenter
Gina Rodriguez	"8/24/21, 3:01:04 PM"	"8/24/21, 3:28:22 PM"	27m 17s	grodriguez@agora.org	Presenter
Dana Pacolay	"8/24/21, 3:01:23 PM"	"8/24/21, 3:28:48 PM"	27m 25s	dpacolay@agora.org	Presenter
Chelsey Panchura	"8/24/21, 3:01:29 PM"	"8/24/21, 3:28:42 PM"	27m 13s	cpanchura@agora.org	Presenter
Kymerly Humanick	"8/24/21, 3:01:31 PM"	"8/24/21, 3:28:23 PM"	26m 51s	khumanick@agora.org	Presenter
Valerie Natale	"8/24/21, 3:01:41 PM"	"8/24/21, 3:29:17 PM"	27m 36s	vnatale@agora.org	Presenter
Patrick Lavelle	"8/24/21, 3:01:48 PM"	"8/24/21, 3:28:20 PM"	26m 32s	plavelle@agora.org	Presenter
Janelle Shaffer	"8/24/21, 3:01:48 PM"	"8/24/21, 3:28:20 PM"	26m 32s	jshaffer3@agora.org	Presenter
Kaelyn Hoffman	"8/24/21, 3:01:55 PM"	"8/24/21, 3:28:44 PM"	26m 48s	khoffman@agora.org	Presenter
Heidi Dodge	"8/24/21, 3:02:23 PM"	"8/24/21, 3:28:31 PM"	26m 8s	hdodge@agora.org	Presenter
Erin Scrip	"8/24/21, 3:02:24 PM"	"8/24/21, 3:17:29 PM"	15m 5s	escrip@agora.org	Presenter
Erin Scrip	"8/24/21, 3:20:42 PM"	"8/24/21, 3:34:19 PM"	13m 37s	escrip@agora.org	Presenter
Julie Doebereiner	"8/24/21, 3:03:14 PM"	"8/24/21, 3:35:44 PM"	32m 29s	jdoebereiner@agora.org	Presenter
Olivia Eckels	"8/24/21, 3:04:33 PM"	"8/24/21, 3:28:25 PM"	23m 51s	oekels@agora.org	Presenter
Danielle Schall	"8/24/21, 3:04:57 PM"	"8/24/21, 3:28:26 PM"	23m 28s	dschall@agora.org	Presenter
Sasha Young	"8/24/21, 3:05:09 PM"	"8/24/21, 3:28:21 PM"	23m 11s	syoung@agora.org	Presenter
Lauren Radico	"8/24/21, 3:05:25 PM"	"8/24/21, 3:29:20 PM"	23m 54s	lradico@agora.org	Presenter
Heather Gallagher	"8/24/21, 3:05:43 PM"	"8/24/21, 3:30:28 PM"	24m 45s	hgallagher@agora.org	Presenter
Erin Connor	"8/24/21, 3:06:23 PM"	"8/24/21, 3:11:02 PM"	4m 39s	econnor@agora.org	Presenter
Whitney Bargerstock	"8/24/21, 3:07:41 PM"	"8/24/21, 3:30:56 PM"	23m 14s	wbargerstock@agora.org	Presenter
Kimberly Fiscus	"8/24/21, 3:07:46 PM"	"8/24/21, 3:28:19 PM"	20m 32s	kfiscus@agora.org	Presenter
Colleen Freyvogel Bruss	"8/24/21, 3:08:58 PM"	"8/24/21, 3:28:22 PM"	19m 23s	cfreyvogel@agora.org	Presenter

Mindy Wesley "8/24/21, 3:13:21 PM""8/24/21, 3:14:30 PM"1m 9s mwesley@agora.org Presenter  
Christine Thomas "8/24/21, 3:15:15 PM""8/24/21, 3:28:24 PM"13m 8s cthomas@agora.org  
Presenter  
Erinn Slacktish "8/24/21, 3:15:21 PM""8/24/21, 3:28:21 PM"13m eslacktish@agora.org Presenter  
Kimberly McLaughlin "8/24/21, 3:26:26 PM""8/24/21, 3:28:31 PM"2m 5s kmclaughlin@agora.org  
Presenter

# Agenda

- Orientation
- Atlas
- Lesson Plans & Expectations
- Half Dy Schedules
- Newly Enrolled Students/Expectations
- PD Schedule & Questions

## 1. Summary

Attended participants 22

Start time "8/23/21, 10:54:46 AM"

End time "8/23/21, 11:30:19 AM"

Meeting duration 35m 32s

Average attendance time 28m 55s

## 2. Participants

Name	First join	Last leave	In-meeting duration	Email	Participant ID (UPN)	Role
Lauren Svonavec	"8/23/21, 10:55:00 AM"	"8/23/21, 11:29:37 AM"	34m 36s	lsvonavec@agora.org	lsvonavec@agora.org	Presenter
Cathryn Mack	"8/23/21, 10:55:10 AM"	"8/23/21, 11:30:19 AM"	35m 8s	cmack@agora.org	cmack@agora.org	Presenter
Maryann Johnson	"8/23/21, 10:55:18 AM"	"8/23/21, 11:30:11 AM"	34m 53s	majohnson@agora.org	majohnson@agora.org	Organizer
Michelle Pelissier	"8/23/21, 10:55:44 AM"	"8/23/21, 11:29:11 AM"	33m 26s	mpelissier@agora.org	mpelissier@agora.org	Presenter
Leslie Spratt	"8/23/21, 10:55:58 AM"	"8/23/21, 11:29:34 AM"	33m 35s	lspratt@agora.org	lspratt@agora.org	Presenter
Molly Garczynski	"8/23/21, 10:56:43 AM"	"8/23/21, 11:29:30 AM"	32m 47s	mgarczynski@agora.org	mgarczynski@agora.org	Presenter
Heidi Dodge	"8/23/21, 10:57:37 AM"	"8/23/21, 11:29:31 AM"	31m 53s	hdodge@agora.org	hdodge@agora.org	Presenter
Maria Harlan	"8/23/21, 10:58:32 AM"	"8/23/21, 11:29:33 AM"	31m 1s	mharlan@agora.org	mharlan@agora.org	Presenter
Jessica Linderman	"8/23/21, 10:58:33 AM"	"8/23/21, 11:29:39 AM"	31m 5s	jlinderman@agora.org	jlinderman@agora.org	Presenter
Stacy Vietmeier	"8/23/21, 10:58:48 AM"	"8/23/21, 11:29:35 AM"	30m 46s	svietmeier@agora.org	svietmeier@agora.org	Presenter
Jennifer Fisher Clark	"8/23/21, 10:58:55 AM"	"8/23/21, 11:06:04 AM"	7m 9s	jclark@agora.org	jclark@agora.org	Presenter
Kristina Lapsker	"8/23/21, 10:59:07 AM"	"8/23/21, 11:30:06 AM"	30m 58s	klapsker@agora.org	klapsker@agora.org	Presenter
Dana O'Donnell	"8/23/21, 10:59:20 AM"	"8/23/21, 11:29:35 AM"	30m 14s	Dodonnell@agora.org	Dodonnell@agora.org	Presenter
Sarah Pittman	"8/23/21, 10:59:55 AM"	"8/23/21, 11:29:36 AM"	29m 40s	spittman@agora.org	spittman@agora.org	Presenter
Brittney Cantwell	"8/23/21, 10:59:57 AM"	"8/23/21, 11:29:38 AM"	29m 41s	bcantwell@agora.org	bcantwell@agora.org	Presenter
Anna Lepsch	"8/23/21, 11:00:05 AM"	"8/23/21, 11:29:48 AM"	29m 43s	alepsch@agora.org	alepsch@agora.org	Presenter
Kymberly Humanick	"8/23/21, 11:00:10 AM"	"8/23/21, 11:29:30 AM"	29m 19s	khumanick@agora.org	khumanick@agora.org	Presenter
Kelly Berstecher	"8/23/21, 11:00:51 AM"	"8/23/21, 11:29:33 AM"	28m 41s	kberstecher@agora.org	kberstecher@agora.org	Presenter
David Furka	"8/23/21, 11:01:56 AM"	"8/23/21, 11:29:25 AM"	27m 29s	dfurka@agora.org	dfurka@agora.org	Presenter
Gillian Kaufman	"8/23/21, 11:02:07 AM"	"8/23/21, 11:29:35 AM"	27m 28s	gkaufman@agora.org	gkaufman@agora.org	Presenter
Kimberly Paolino	"8/23/21, 11:02:49 AM"	"8/23/21, 11:29:55 AM"	27m 5s	kpaolino@agora.org	kpaolino@agora.org	Presenter
Brittany Reamer	"8/23/21, 11:19:51 AM"	"8/23/21, 11:29:42 AM"	9m 51s	breamer@agora.org	breamer@agora.org	Presenter

## 3. In-Meeting activities

Name	Join time	Leave time	Duration	Email	Role
------	-----------	------------	----------	-------	------

Lauren Svonavec lsvonavec@agora.org Presenter	"8/23/21, 10:55:00 AM"	"8/23/21, 11:29:37 AM"	34m 36s	
Cathryn Mack Presenter	"8/23/21, 10:55:10 AM"	"8/23/21, 11:30:19 AM"	35m 8s	cmack@agora.org
Maryann Johnson majohnson@agora.org Organizer	"8/23/21, 10:55:18 AM"	"8/23/21, 11:30:11 AM"	34m 53s	
Michelle Pelissier Presenter	"8/23/21, 10:55:44 AM"	"8/23/21, 11:29:11 AM"	33m 26s	mpelissier@agora.org
Leslie Spratt Presenter	"8/23/21, 10:55:58 AM"	"8/23/21, 11:29:34 AM"	33m 35s	lspratt@agora.org
Molly Garczynski Presenter	"8/23/21, 10:56:43 AM"	"8/23/21, 11:29:30 AM"	32m 47s	mgarczynski@agora.org
Heidi Dodge Presenter	"8/23/21, 10:57:37 AM"	"8/23/21, 11:29:31 AM"	31m 53s	hdodge@agora.org
Maria Harlan Presenter	"8/23/21, 10:58:32 AM"	"8/23/21, 11:29:33 AM"	31m 1s	mharlan@agora.org
Jessica Linderman jlinderman@agora.org Presenter	"8/23/21, 10:58:33 AM"	"8/23/21, 11:29:39 AM"	31m 5s	
Stacy Vietmeier Presenter	"8/23/21, 10:58:48 AM"	"8/23/21, 11:29:35 AM"	30m 46s	svietmeier@agora.org
Jennifer Fisher Clark Presenter	"8/23/21, 10:58:55 AM"	"8/23/21, 11:06:04 AM"	7m 9s	jclark@agora.org
Kristina Lapsker Presenter	"8/23/21, 10:59:07 AM"	"8/23/21, 11:30:06 AM"	30m 58s	klapsker@agora.org
Dana O'Donnell Presenter	"8/23/21, 10:59:20 AM"	"8/23/21, 11:29:35 AM"	30m 14s	Dodonnell@agora.org
Sarah Pittman Presenter	"8/23/21, 10:59:55 AM"	"8/23/21, 11:29:36 AM"	29m 40s	spittman@agora.org
Brittney Cantwell Presenter	"8/23/21, 10:59:57 AM"	"8/23/21, 11:29:38 AM"	29m 41s	bcantwell@agora.org
Anna Lepsch Presenter	"8/23/21, 11:00:05 AM"	"8/23/21, 11:29:48 AM"	29m 43s	alepsch@agora.org
Kymerly Humanick khumanick@agora.org Presenter	"8/23/21, 11:00:10 AM"	"8/23/21, 11:29:30 AM"	29m 19s	
Kelly Berstecher Presenter	"8/23/21, 11:00:51 AM"	"8/23/21, 11:29:33 AM"	28m 41s	kberstecher@agora.org
David Furka Presenter	"8/23/21, 11:01:56 AM"	"8/23/21, 11:29:25 AM"	27m 29s	dfurka@agora.org
Gillian Kaufman Presenter	"8/23/21, 11:02:07 AM"	"8/23/21, 11:29:35 AM"	27m 28s	gkaufman@agora.org
Kimberly Paolino Presenter	"8/23/21, 11:02:49 AM"	"8/23/21, 11:29:55 AM"	27m 5s	kpaolino@agora.org
Brittany Reamer Presenter	"8/23/21, 11:19:51 AM"	"8/23/21, 11:29:42 AM"	9m 51s	breamer@agora.org

# CONDUCT FOR PROVIDING IN-HOME AND VIRTUAL SERVICES AGENDA

- Thank you!!
- Expectations:Accepting the Case
- Expectations:What should I do if I cannot schedule?
- Expectations:What should I do if the Student missed sessions?
- Expectations in the Home:Arriving at the Home and Cancellations
- Expectations in the Home: Safety
- Expectations in the Home: Health & Safety Plan
- Expectations in the Home: Conduct
- Expectations in the Home: Confidentiality
- Expectations in the virtual setting
- Provider Names and Logging Into NewRow
- Expectations in Newrow
- Communication in NewRow
- Expectations: Communication
- Questions or Concerns regarding Curriculum, Instruction, Etc.
- Above all else...
- Any Questions?

## Meeting Summary

Total Number of Participants 137  
Meeting Title Related Services Training  
Meeting Start Time "8/26/2021, 2:45:03 PM"  
Meeting End Time "8/26/2021, 4:02:57 PM"  
Meeting Id f527cca7-bc75-41a1-9432-532215889006

Full Name	Join Time	Leave Time	Duration	Email	Role	Participant ID (UPN)
Melanie Stanforth	"8/26/2021, 2:45:03 PM"	"8/26/2021, 3:48:24 PM"	1h 3m	mstanforth@agora.org		mstanforth@agora.org
Presenter	mstanforth@agora.org					
Michelle Pelissier	"8/26/2021, 2:45:09 PM"	"8/26/2021, 3:43:39 PM"	58m 30s	mpelissier@agora.org		mpelissier@agora.org
Presenter	mpelissier@agora.org					
Amy Raught	"8/26/2021, 2:45:12 PM"	"8/26/2021, 4:02:57 PM"	1h 17m	araught@agora.org		araught@agora.org
Presenter	araught@agora.org					
Cathryn Mack	"8/26/2021, 2:45:16 PM"	"8/26/2021, 3:43:26 PM"	58m 9s	cmack@agora.org	Presenter	cmack@agora.org
Presenter	cmack@agora.org					
Melissa Gaso	"8/26/2021, 2:45:18 PM"	"8/26/2021, 3:43:25 PM"	58m 7s	mgaso@agora.org	Presenter	mgaso@agora.org
Presenter	mgaso@agora.org					
Joseph Passante	"8/26/2021, 2:45:21 PM"	"8/26/2021, 3:48:21 PM"	1h 2m	jpassante@agora.org		jpassante@agora.org
Presenter	jpassante@agora.org					
Janet Ulewicz	"8/26/2021, 2:45:23 PM"	"8/26/2021, 3:43:24 PM"	58m 1s	julewicz@agora.org	Presenter	julewicz@agora.org
Presenter	julewicz@agora.org					
Justin Groshon	"8/26/2021, 2:45:24 PM"	"8/26/2021, 3:46:12 PM"	1h	jpgroshon@agora.org	Presenter	jpgroshon@agora.org
Presenter	jpgroshon@agora.org					
Judy Deemer	"8/26/2021, 2:45:26 PM"	"8/26/2021, 3:43:29 PM"	58m 3s	jdeemer@agora.org		jdeemer@agora.org
Presenter	jdeemer@agora.org					
Samantha Bonniger	"8/26/2021, 2:46:14 PM"	"8/26/2021, 3:43:51 PM"	57m 36s	sbonniger@agora.org		sbonniger@agora.org
Presenter	sbonniger@agora.org					
Heather Silberman	"8/26/2021, 2:47:14 PM"	"8/26/2021, 3:43:24 PM"	56m 9s	hsilberman@agora.org		hsilberman@agora.org
Presenter	hsilberman@agora.org					
Theresa Bash	"8/26/2021, 2:48:27 PM"	"8/26/2021, 3:43:24 PM"	54m 56s	tbash@agora.org	Presenter	tbash@agora.org
Presenter	tbash@agora.org					
Susan Lelko	"8/26/2021, 2:48:29 PM"	"8/26/2021, 3:43:28 PM"	54m 59s	slelko@agora.org	Presenter	slelko@agora.org
Presenter	slelko@agora.org					
Jennifer Flatley	"8/26/2021, 2:49:23 PM"	"8/26/2021, 3:43:22 PM"	53m 58s	jflatley@agora.org		jflatley@agora.org
Presenter	jflatley@agora.org					
Jodeen Buckwalter	"8/26/2021, 2:49:27 PM"	"8/26/2021, 3:07:46 PM"	18m 18s	jbuckwalter@agora.org		jbuckwalter@agora.org
Presenter	jbuckwalter@agora.org					
Tracey Ambuka	"8/26/2021, 2:49:40 PM"	"8/26/2021, 3:43:40 PM"	54m	tambuka@agora.org		tambuka@agora.org
Presenter	tambuka@agora.org					
Katie O'Donnell	"8/26/2021, 2:51:09 PM"	"8/26/2021, 3:46:20 PM"	55m 11s	kodonnell@agora.org		kodonnell@agora.org
Presenter	kodonnell@agora.org					
Lisa Savitz	"8/26/2021, 2:52:21 PM"	"8/26/2021, 3:43:42 PM"	51m 20s	lsavitz@agora.org	Presenter	lsavitz@agora.org
Presenter	lsavitz@agora.org					
Kaelyn Hoffman	"8/26/2021, 2:52:23 PM"	"8/26/2021, 3:43:36 PM"	51m 12s	khoffman@agora.org		khoffman@agora.org
Presenter	khoffman@agora.org					
Amanda Armstrong	"8/26/2021, 2:52:42 PM"	"8/26/2021, 3:43:41 PM"	50m 58s	aarmstrong@agora.org		aarmstrong@agora.org
Presenter	aarmstrong@agora.org					
Sarah Pittman	"8/26/2021, 2:52:51 PM"	"8/26/2021, 3:43:30 PM"	50m 38s	spittman@agora.org		spittman@agora.org
Presenter	spittman@agora.org					
Kristal Costanzo	"8/26/2021, 2:53:06 PM"	"8/26/2021, 3:43:39 PM"	50m 32s	kcostanzo@agora.org		kcostanzo@agora.org
Presenter	kcostanzo@agora.org					
Kimberly Paolino	"8/26/2021, 2:53:11 PM"	"8/26/2021, 3:43:24 PM"	50m 13s	kpaolino@agora.org		kpaolino@agora.org
Presenter	kpaolino@agora.org					
Lauren Lamison	"8/26/2021, 2:53:13 PM"	"8/26/2021, 3:43:22 PM"	50m 8s	llamison@agora.org		llamison@agora.org
Presenter	llamison@agora.org					

Allison Large "8/26/2021, 2:53:18 PM" "8/26/2021, 3:43:29 PM" 50m 11s alarge@agora.org Presenter  
alarge@agora.org

Amber Brisbane "8/26/2021, 2:53:32 PM" "8/26/2021, 3:43:24 PM" 49m 51s abrisbane@agora.org  
Presenter abrisbane@agora.org

Marlee Atwood "8/26/2021, 2:53:38 PM" "8/26/2021, 3:43:28 PM" 49m 50s matwood@agora.org  
Presenter matwood@agora.org

Carmen Riggie "8/26/2021, 2:53:50 PM" "8/26/2021, 3:43:22 PM" 49m 32s criggie@agora.org  
Presenter criggie@agora.org

Lauren Kerns "8/26/2021, 2:53:54 PM" "8/26/2021, 3:43:34 PM" 49m 39s lkerns@agora.org  
Presenter lkerns@agora.org

Rachel Carmichael "8/26/2021, 2:54:04 PM" "8/26/2021, 3:43:50 PM" 49m 45s rcarmichael@agora.org  
Presenter rcarmichael@agora.org

Regina Kubica "8/26/2021, 2:54:09 PM" "8/26/2021, 3:43:27 PM" 49m 17s rkubica@agora.org  
Presenter rkubica@agora.org

Susan Lipiec "8/26/2021, 2:54:22 PM" "8/26/2021, 3:45:42 PM" 51m 19s slipiec@agora.org Presenter  
slipiec@agora.org

Melissa Love "8/26/2021, 2:54:28 PM" "8/26/2021, 3:43:24 PM" 48m 55s mlove@agora.org Presenter  
mlove@agora.org

Amanda Moyer "8/26/2021, 2:54:45 PM" "8/26/2021, 3:43:43 PM" 48m 57s amoyer@agora.org  
Presenter amoyer@agora.org

Laura Stapf "8/26/2021, 2:55:18 PM" "8/26/2021, 3:43:36 PM" 48m 17s lstapf@agora.org Presenter  
lstapf@agora.org

Jennifer Beeken "8/26/2021, 2:55:18 PM" "8/26/2021, 3:43:40 PM" 48m 22s jbeeken@agora.org  
Presenter jbeeken@agora.org

Veronica Jackson "8/26/2021, 2:55:22 PM" "8/26/2021, 3:45:07 PM" 49m 45s vjackson@agora.org  
Presenter vjackson@agora.org

Jill Moyer "8/26/2021, 2:55:26 PM" "8/26/2021, 3:43:33 PM" 48m 6s jmoyer2@agora.org Presenter  
jmoyer2@agora.org

Regina Mallon "8/26/2021, 2:55:37 PM" "8/26/2021, 3:43:29 PM" 47m 51s gmallon@agora.org  
Presenter gmallon@agora.org

Janelle Shaffer "8/26/2021, 2:55:38 PM" "8/26/2021, 3:43:37 PM" 47m 59s jshaffer3@agora.org  
Presenter jshaffer3@agora.org

Melissa Stump "8/26/2021, 2:55:39 PM" "8/26/2021, 3:43:24 PM" 47m 44s mstump@agora.org  
Presenter mstump@agora.org

Terri Hunkele "8/26/2021, 2:55:42 PM" "8/26/2021, 3:43:40 PM" 47m 57s thunkele@agora.org  
Presenter thunkele@agora.org

Shari Widlund "8/26/2021, 2:55:43 PM" "8/26/2021, 3:43:23 PM" 47m 39s swidlund@agora.org  
Presenter swidlund@agora.org

Keri Shannon "8/26/2021, 2:55:44 PM" "8/26/2021, 3:43:35 PM" 47m 51s kshannon@agora.org  
Presenter kshannon@agora.org

Heather Gallagher "8/26/2021, 2:55:46 PM" "8/26/2021, 3:43:43 PM" 47m 56s hgallagher@agora.org  
Presenter hgallagher@agora.org

Jenna Lee Dietrich "8/26/2021, 2:55:53 PM" "8/26/2021, 3:43:24 PM" 47m 30s jdietrich@agora.org  
Presenter jdietrich@agora.org

Tamara Kozak "8/26/2021, 2:56:06 PM" "8/26/2021, 3:43:34 PM" 47m 27s tkozak@agora.org  
Presenter tkozak@agora.org

Danielle Pricer "8/26/2021, 2:56:07 PM" "8/26/2021, 3:43:58 PM" 47m 51s dpricer@agora.org Presenter  
dpricer@agora.org

Rebekah Congdon "8/26/2021, 2:56:19 PM" "8/26/2021, 3:43:21 PM" 47m 2s rcongdon@agora.org  
Presenter rcongdon@agora.org

Shannon Feeney Hoffmaster "8/26/2021, 2:56:30 PM" "8/26/2021, 3:43:27 PM" 46m 56s  
shoffmaster@agora.org Presenter shoffmaster@agora.org

Ashley Schmidt "8/26/2021, 2:56:37 PM" "8/26/2021, 3:43:20 PM" 46m 42s aschmidt@agora.org  
Presenter aschmidt@agora.org

Kristina Lapsker "8/26/2021, 2:56:38 PM" "8/26/2021, 3:43:23 PM" 46m 45s klapsker@agora.org  
Presenter klapsker@agora.org

Serena Adams "8/26/2021, 2:56:43 PM" "8/26/2021, 3:43:26 PM" 46m 42s sadams@agora.org



Presenter sadams@agora.org  
 Theresa Draeger "8/26/2021, 2:56:49 PM" "8/26/2021, 3:45:03 PM" 48m 14s tdraeger@agora.org  
 Presenter tdraeger@agora.org  
 Melissa Hale-Patterson "8/26/2021, 2:56:49 PM" "8/26/2021, 3:43:40 PM" 46m 50s mpatterson@agora.org  
 Presenter mpatterson@agora.org  
 Joy Fegely "8/26/2021, 2:56:52 PM" "8/26/2021, 3:43:23 PM" 46m 30s jfegely@agora.org Presenter  
 jfegely@agora.org  
 Jennifer Buss "8/26/2021, 2:56:57 PM" "8/26/2021, 3:43:29 PM" 46m 32s jbuss@agora.org Presenter  
 jbuss@agora.org  
 Jessica Barnhart "8/26/2021, 2:57:08 PM" "8/26/2021, 3:43:41 PM" 46m 33s jbarnhart@agora.org  
 Presenter jbarnhart@agora.org  
 Brett Stevens "8/26/2021, 2:57:17 PM" "8/26/2021, 3:43:26 PM" 46m 8s bstevens2@agora.org  
 Presenter bstevens2@agora.org  
 Jennifer Zollman "8/26/2021, 2:57:17 PM" "8/26/2021, 3:43:34 PM" 46m 16s jzollman@agora.org  
 Presenter jzollman@agora.org  
 Shelley Stump "8/26/2021, 2:57:18 PM" "8/26/2021, 3:43:28 PM" 46m 9s sstump@agora.org  
 Presenter sstump@agora.org  
 Brittany Froehlich "8/26/2021, 2:57:30 PM" "8/26/2021, 3:43:23 PM" 45m 52s BFroehlich@agora.org  
 Presenter BFroehlich@agora.org  
 Laurie Super "8/26/2021, 2:57:31 PM" "8/26/2021, 3:43:40 PM" 46m 8s lsuper@agora.org Presenter  
 lsuper@agora.org  
 Morgan Witman "8/26/2021, 2:57:32 PM" "8/26/2021, 3:43:26 PM" 45m 53s mwitman@agora.org  
 Presenter mwitman@agora.org  
 Stacy Vietmeier "8/26/2021, 2:57:57 PM" "8/26/2021, 3:43:35 PM" 45m 37s svietmeier@agora.org  
 Presenter svietmeier@agora.org  
 Amber Staley "8/26/2021, 2:57:59 PM" "8/26/2021, 3:43:34 PM" 45m 34s astaley2@agora.org  
 Presenter astaley2@agora.org  
 Sasha Young "8/26/2021, 2:58:03 PM" "8/26/2021, 3:43:33 PM" 45m 29s syoung@agora.org  
 Presenter syoung@agora.org  
 Ashley Farster "8/26/2021, 2:58:09 PM" "8/26/2021, 3:43:33 PM" 45m 23s afarster@agora.org  
 Presenter afarster@agora.org  
 Kimberly McLaughlin "8/26/2021, 2:58:10 PM" "8/26/2021, 3:49:09 PM" 50m 58s  
 kmclaughlin@agora.org Presenter kmclaughlin@agora.org  
 Chris Baker "8/26/2021, 2:58:12 PM" "8/26/2021, 3:02:58 PM" 4m 46s cbaker@agora.org  
 Presenter cbaker@agora.org  
 Chris Baker "8/26/2021, 3:04:43 PM" "8/26/2021, 3:43:32 PM" 38m 49s cbaker@agora.org  
 Presenter cbaker@agora.org  
 Colien Byers "8/26/2021, 2:58:19 PM" "8/26/2021, 3:43:40 PM" 45m 20s cbyers@agora.org  
 Presenter cbyers@agora.org  
 Brianna Pontious "8/26/2021, 2:58:20 PM" "8/26/2021, 3:43:31 PM" 45m 11s bpontious@agora.org  
 Presenter bpontious@agora.org  
 Ashley Salimbene "8/26/2021, 2:58:20 PM" "8/26/2021, 3:43:26 PM" 45m 6s  
 asalimbene@agora.org Presenter asalimbene@agora.org  
 Molly Garczynski "8/26/2021, 2:58:24 PM" "8/26/2021, 3:43:32 PM" 45m 7s mgarczynski@agora.org  
 Presenter mgarczynski@agora.org  
 Valerie Natale "8/26/2021, 2:58:26 PM" "8/26/2021, 3:16:12 PM" 17m 45s vnatale@agora.org  
 Presenter vnatale@agora.org  
 Valerie Natale "8/26/2021, 3:17:18 PM" "8/26/2021, 3:43:35 PM" 26m 16s vnatale@agora.org  
 Presenter vnatale@agora.org  
 Jennifer DePietro "8/26/2021, 2:58:27 PM" "8/26/2021, 3:43:35 PM" 45m 7s  
 jdepietro@agora.org Presenter jdepietro@agora.org  
 Kayla Flores "8/26/2021, 2:58:31 PM" "8/26/2021, 3:43:46 PM" 45m 15s kflores@agora.org  
 Presenter kflores@agora.org  
 Kattreena Amodeo "8/26/2021, 2:58:40 PM" "8/26/2021, 3:43:29 PM" 44m 48s  
 kamodeo@agora.org Presenter kamodeo@agora.org  
 Gemma Mattox "8/26/2021, 2:58:42 PM" "8/26/2021, 3:43:32 PM" 44m 49s gmattox@agora.org  
 Presenter gmattox@agora.org

Lauren Svonavec	"8/26/2021, 2:58:47 PM"	"8/26/2021, 3:43:22 PM"	44m 35s	
lsvonavec@agora.org	Presenter	lsvonavec@agora.org		
Sabrina Kennedy	"8/26/2021, 2:58:49 PM"	"8/26/2021, 3:43:31 PM"	44m 41s	skennedy@agora.org
Presenter		skennedy@agora.org		
Angela Denham	"8/26/2021, 2:58:51 PM"	"8/26/2021, 3:43:29 PM"	44m 37s	adenham@agora.org
Presenter		adenham@agora.org		
Cathryn Ramsey	"8/26/2021, 2:59:06 PM"	"8/26/2021, 3:43:21 PM"	44m 14s	cramsey@agora.org
Presenter		cramsey@agora.org		
Cathrine Hartman	"8/26/2021, 2:59:08 PM"	"8/26/2021, 3:43:38 PM"	44m 30s	
chartman@agora.org	Presenter	chartman@agora.org		
Jennifer McGinty	"8/26/2021, 2:59:18 PM"	"8/26/2021, 3:43:30 PM"	44m 11s	jmcginty@agora.org
Presenter		jmcginty@agora.org		
Whitney Bargerstock	"8/26/2021, 2:59:23 PM"	"8/26/2021, 3:43:52 PM"	44m 28s	
wbargerstock@agora.org	Presenter	wbargerstock@agora.org		
Breanne Scears	"8/26/2021, 2:59:25 PM"	"8/26/2021, 3:43:41 PM"	44m 15s	bscears@agora.org
Presenter		bscears@agora.org		
Erin Connor	"8/26/2021, 2:59:27 PM"	"8/26/2021, 3:43:25 PM"	43m 58s	econnor@agora.org
Presenter		econnor@agora.org		
Erinn Slacktish	"8/26/2021, 2:59:27 PM"	"8/26/2021, 3:43:25 PM"	43m 57s	eslacktish@agora.org
Presenter		eslacktish@agora.org		
Rachel Weeks	"8/26/2021, 2:59:28 PM"	"8/26/2021, 3:43:22 PM"	43m 54s	rweeks@agora.org
Presenter		rweeks@agora.org		
Jesse Capitano	"8/26/2021, 2:59:31 PM"	"8/26/2021, 3:43:35 PM"	44m 4s	jcapitano@agora.org
Presenter		jcapitano@agora.org		
Maria Harlan	"8/26/2021, 2:59:32 PM"	"8/26/2021, 3:43:37 PM"	44m 4s	mharlan@agora.org
Presenter		mharlan@agora.org		
Amirah McIntyre	"8/26/2021, 2:59:33 PM"	"8/26/2021, 3:27:10 PM"	27m 36s	amcintyre@agora.org
Presenter		amcintyre@agora.org		
Amirah McIntyre	"8/26/2021, 3:28:43 PM"	"8/26/2021, 3:28:44 PM"	1s	amcintyre@agora.org
Presenter		amcintyre@agora.org		
Amirah McIntyre	"8/26/2021, 3:32:41 PM"	"8/26/2021, 3:43:26 PM"	10m 44s	amcintyre@agora.org
Presenter		amcintyre@agora.org		
Bridget Ellis	"8/26/2021, 2:59:33 PM"	"8/26/2021, 3:43:28 PM"	43m 54s	bellis@agora.org
Presenter		bellis@agora.org		
Danielle Schall	"8/26/2021, 2:59:36 PM"	"8/26/2021, 3:43:41 PM"	44m 4s	dschall@agora.org
Presenter		dschall@agora.org		
Brittany Kieffer	"8/26/2021, 2:59:37 PM"	"8/26/2021, 3:43:30 PM"	43m 53s	bkieffer@agora.org
Presenter		bkieffer@agora.org		
Carissa Emrick	"8/26/2021, 2:59:40 PM"	"8/26/2021, 3:44:01 PM"	44m 20s	cemrick@agora.org
Presenter		cemrick@agora.org		
Heidi Dodge	"8/26/2021, 2:59:42 PM"	"8/26/2021, 3:43:38 PM"	43m 55s	hdodge@agora.org
Presenter		hdodge@agora.org		
Jena Huffman	"8/26/2021, 2:59:49 PM"	"8/26/2021, 3:43:28 PM"	43m 38s	jhuffman@agora.org
Presenter		jhuffman@agora.org		
Maura Basso	"8/26/2021, 2:59:49 PM"	"8/26/2021, 3:38:20 PM"	38m 30s	mbasso@agora.org
Presenter		mbasso@agora.org		
Jessica Linderman	"8/26/2021, 2:59:53 PM"	"8/26/2021, 3:43:39 PM"	43m 46s	
jlinderman@agora.org	Presenter	jlinderman@agora.org		
Barry Sigal	"8/26/2021, 2:59:53 PM"	"8/26/2021, 3:29:04 PM"	29m 10s	bsigal@agora.org
Presenter		bsigal@agora.org		
Leslie Spratt	"8/26/2021, 2:59:54 PM"	"8/26/2021, 3:43:37 PM"	43m 43s	lspratt@agora.org
Presenter		lspratt@agora.org		
Lynn Pagliei	"8/26/2021, 2:59:55 PM"	"8/26/2021, 3:43:19 PM"	43m 23s	lpagliei@agora.org
Presenter		lpagliei@agora.org		
Jennifer Cadieux	"8/26/2021, 2:59:56 PM"	"8/26/2021, 3:43:38 PM"	43m 42s	jcadieus@agora.org
Presenter		jcadieus@agora.org		
Dana Pacolay	"8/26/2021, 3:00:01 PM"	"8/26/2021, 3:43:47 PM"	43m 46s	dpacolay@agora.org

Presenter dpacolay@agora.org				
Nancy Reimers	"8/26/2021, 3:00:08 PM"	"8/26/2021, 3:43:41 PM"	43m 33s	nreimers@agora.org
Presenter nreimers@agora.org				
Karen Siwik	"8/26/2021, 3:00:09 PM"	"8/26/2021, 3:27:24 PM"	27m 15s	ksiwik@agora.org
Presenter ksiwik@agora.org				
Olivia Eckels	"8/26/2021, 3:00:09 PM"	"8/26/2021, 3:43:40 PM"	43m 31s	oeckels@agora.org
Presenter oeckels@agora.org				
Kymerly Humanick	"8/26/2021, 3:00:27 PM"	"8/26/2021, 3:32:54 PM"	32m 27s	
khumanick@agora.org				
Presenter khumanick@agora.org				
Kimberly Fiscus	"8/26/2021, 3:00:29 PM"	"8/26/2021, 3:43:30 PM"	43m 1s	kfiscus@agora.org
Presenter kfiscus@agora.org				
Lisa Brestensky	"8/26/2021, 3:00:33 PM"	"8/26/2021, 3:45:25 PM"	44m 52s	lbrestensky@agora.org
Presenter lbrestensky@agora.org				
Anna Lepsch	"8/26/2021, 3:00:34 PM"	"8/26/2021, 3:43:29 PM"	42m 55s	alepsch@agora.org
Presenter alepsch@agora.org				
Casey Chaffin	"8/26/2021, 3:00:36 PM"	"8/26/2021, 3:43:31 PM"	42m 55s	cchaffin@agora.org
Presenter cchaffin@agora.org				
Brittany Reamer	"8/26/2021, 3:00:38 PM"	"8/26/2021, 3:43:23 PM"	42m 44s	breamer@agora.org
Presenter breamer@agora.org				
Chelsey Panchura	"8/26/2021, 3:00:40 PM"	"8/26/2021, 3:43:39 PM"	42m 59s	
cpanchura@agora.org				
Presenter cpanchura@agora.org				
Renee Perri	"8/26/2021, 3:00:41 PM"	"8/26/2021, 3:43:29 PM"	42m 47s	rperri@agora.org
Presenter rperri@agora.org				
Nicole Krol	"8/26/2021, 3:00:45 PM"	"8/26/2021, 3:43:32 PM"	42m 46s	nkrol@agora.org
Presenter nkrol@agora.org				
Melissa McCracken	"8/26/2021, 3:00:51 PM"	"8/26/2021, 3:43:25 PM"	42m 34s	
mmccracken@agora.org				
Presenter mmccracken@agora.org				
Jill Severino	"8/26/2021, 3:01:27 PM"	"8/26/2021, 3:43:45 PM"	42m 17s	jseverino@agora.org
Presenter jseverino@agora.org				
Erin Scrip	"8/26/2021, 3:01:50 PM"	"8/26/2021, 3:51:52 PM"	50m 1s	escrip@agora.org
Presenter escrip@agora.org				
Jen Lucia	"8/26/2021, 3:02:21 PM"	"8/26/2021, 3:44:04 PM"	41m 42s	jlucia@agora.org
Presenter jlucia@agora.org				
Colleen Freyvogel Bruss	"8/26/2021, 3:02:35 PM"	"8/26/2021, 3:43:39 PM"	41m 4s	
cfreyvogel@agora.org				
Presenter cfreyvogel@agora.org				
Cortney Barkley	"8/26/2021, 3:02:58 PM"	"8/26/2021, 3:44:00 PM"	41m 2s	cbarkley@agora.org
Presenter cbarkley@agora.org				
Patrick Lavelle	"8/26/2021, 3:03:29 PM"	"8/26/2021, 3:47:03 PM"	43m 33s	plavelle@agora.org
Presenter plavelle@agora.org				
Anna Baranoski	"8/26/2021, 3:04:46 PM"	"8/26/2021, 3:43:40 PM"	38m 54s	abaranoski@agora.org
Presenter abaranoski@agora.org				
Amanda Kammermeier	"8/26/2021, 3:04:53 PM"	"8/26/2021, 3:43:47 PM"	38m 54s	
akammermeier@agora.org				
Presenter akammermeier@agora.org				
Melissa Franklin	"8/26/2021, 3:05:09 PM"	"8/26/2021, 3:43:34 PM"	38m 24s	mfranklin@agora.org
Presenter mfranklin@agora.org				
Gina Rodriguez	"8/26/2021, 3:05:18 PM"	"8/26/2021, 3:43:40 PM"	38m 21s	grodriguez@agora.org
Presenter grodriguez@agora.org				
Lauren Radico	"8/26/2021, 3:05:24 PM"	"8/26/2021, 3:44:24 PM"	38m 59s	lradico@agora.org
Presenter lradico@agora.org				
Barb Cooper	"8/26/2021, 3:05:44 PM"	"8/26/2021, 3:43:23 PM"	37m 38s	bcooper@agora.org
Presenter bcooper@agora.org				
Tara Walker	"8/26/2021, 3:05:55 PM"	"8/26/2021, 3:43:33 PM"	37m 37s	twalker@agora.org
Presenter twalker@agora.org				
Gillian Kaufman	"8/26/2021, 3:06:10 PM"	"8/26/2021, 3:43:28 PM"	37m 17s	gkaufman@agora.org
Presenter gkaufman@agora.org				
Dana O'Donnell	"8/26/2021, 3:06:19 PM"	"8/26/2021, 3:47:00 PM"	40m 40s	Dodonnell@agora.org
Presenter Dodonnell@agora.org				

David Furka	"8/26/2021, 3:06:25 PM"	"8/26/2021, 3:43:39 PM"	37m 13s	dfurka@agora.org
Presenter	dfurka@agora.org			
Kelly Berstecher	"8/26/2021, 3:06:33 PM"	"8/26/2021, 3:43:38 PM"	37m 4s	kberstecher@agora.org
Presenter	kberstecher@agora.org			
Julie Doebereiner	"8/26/2021, 3:12:06 PM"	"8/26/2021, 3:43:24 PM"	31m 18s	
jdoebereiner@agora.org	Presenter	jdoebereiner@agora.org		

# TRANSITION TRAINING AGENDA



## Items to review today:

- IEP transition planning requirements
- Act 26 PIMS reporting questions
- Agency involvement
- Job training as a related service
- Work study program
- DCA reminders

## Poll the Audience

- A. I am a veteran transition plan writer and feel confident in my transition knowledge.
- B. I have knowledge of transition planning but I'm pretty sure I could use more training.
- C. I am brand new to transition planning and will be referencing this training often.
- D. I will not be writing IEP transition plans this year but want to stay fresh with my transition knowledge.

## 1. Summary

Attended participants 118  
Start time "8/24/21, 11:09:38 AM"  
End time "8/25/21, 9:19:31 AM"  
Meeting duration 22h 9m 53s  
Average attendance time 2h 3m 45s

## 2. Participants

Name	First join	Last leave	In-meeting duration	Email	Participant ID (UPN)	Role
Cathryn Mack	"8/24/21, 11:46:01 AM"	"8/24/21, 2:01:33 PM"	2h 15m 32s	cmack@agora.org	cmack@agora.org	Attendee
Kimberly McLaughlin	"8/24/21, 11:46:19 AM"	"8/24/21, 12:53:27 PM"	1h 7m 8s	kmclaughlin@agora.org	kmclaughlin@agora.org	Attendee
Susan Lelko	"8/24/21, 11:46:21 AM"	"8/24/21, 1:59:06 PM"	2h 11m 16s	slelko@agora.org	slelko@agora.org	Attendee
Brett Stevens	"8/24/21, 11:46:22 AM"	"8/24/21, 2:01:02 PM"	2h 14m 40s	bstevens2@agora.org	bstevens2@agora.org	Attendee
Chris Baker	"8/24/21, 11:48:21 AM"	"8/24/21, 2:01:14 PM"	1h 57m 52s	cbaker@agora.org	cbaker@agora.org	Attendee
Tamara Kozak	"8/24/21, 11:48:56 AM"	"8/24/21, 2:00:07 PM"	2h 11m 11s	tkozak@agora.org	tkozak@agora.org	Attendee
Barb Cooper	"8/24/21, 11:49:05 AM"	"8/24/21, 2:00:59 PM"	2h 11m 53s	bcooper@agora.org	bcooper@agora.org	Attendee
Joy Fegely	"8/24/21, 11:49:59 AM"	"8/24/21, 2:01:03 PM"	2h 11m 4s	jfegely@agora.org	jfegely@agora.org	Attendee
Colien Byers	"8/24/21, 11:50:17 AM"	"8/24/21, 2:00:16 PM"	2h 9m 59s	cbyers@agora.org	cbyers@agora.org	Attendee
Amanda Moyer	"8/24/21, 11:50:42 AM"	"8/24/21, 2:00:14 PM"	2h 9m 32s	amoyer@agora.org	amoyer@agora.org	Attendee
Jennifer Flatley	"8/24/21, 11:50:50 AM"	"8/24/21, 1:59:09 PM"	2h 8m 18s	jflatley@agora.org	jflatley@agora.org	Attendee
Bridget Ellis	"8/24/21, 11:51:22 AM"	"8/24/21, 2:01:06 PM"	2h 9m 43s	bellis@agora.org	bellis@agora.org	Attendee
Allison Large	"8/24/21, 11:51:32 AM"	"8/24/21, 1:59:15 PM"	2h 7m 43s	alarge@agora.org	alarge@agora.org	Attendee
Kristy Welsh	"8/24/21, 11:51:33 AM"	"8/24/21, 1:59:12 PM"	2h 7m 39s	kwelsh@agora.org	kwelsh@agora.org	Attendee
Theresa Bash	"8/24/21, 11:51:41 AM"	"8/24/21, 2:00:56 PM"	2h 9m 15s	tbash@agora.org	tbash@agora.org	Attendee
Regina Kubica	"8/24/21, 11:52:03 AM"	"8/24/21, 1:58:00 PM"	2h 5m 56s	rkubica@agora.org	rkubica@agora.org	Attendee
Kimberly Paolino	"8/24/21, 11:52:53 AM"	"8/24/21, 2:00:24 PM"	2h 7m 31s	kpaolino@agora.org	kpaolino@agora.org	Attendee
Terri Hunkele	"8/24/21, 11:53:14 AM"	"8/24/21, 1:59:41 PM"	2h 6m 27s	thunkele@agora.org	thunkele@agora.org	Attendee
Kattreena Amodeo	"8/24/21, 11:54:07 AM"	"8/24/21, 2:00:32 PM"	2h 6m 25s	kamodeo@agora.org	kamodeo@agora.org	Attendee
Rachel Carmichael	"8/24/21, 11:54:13 AM"	"8/24/21, 2:01:12 PM"	2h 6m 58s	rcarmichael@agora.org	rcarmichael@agora.org	Attendee
Brittany Reamer	"8/24/21, 11:54:19 AM"	"8/24/21, 2:00:54 PM"	2h 6m 34s	breamer@agora.org	breamer@agora.org	Attendee
Jennifer Beeken	"8/24/21, 11:54:33 AM"	"8/24/21, 2:01:12 PM"	2h 6m 38s	jbeeken@agora.org	jbeeken@agora.org	Attendee
Kristal Costanzo	"8/24/21, 11:54:37 AM"	"8/24/21, 2:01:14 PM"	1h 59m 10s	kcostanzo@agora.org	kcostanzo@agora.org	Attendee
Danielle Pricer	"8/24/21, 11:55:10 AM"	"8/24/21, 1:17:25 PM"	1h 17m 2s	dpricer@agora.org	dpricer@agora.org	Attendee

dpricer@agora.org Attendee  
Melissa McCracken "8/24/21, 11:55:14 AM" "8/24/21, 2:00:52 PM" 2h 1m 12s  
mmccracken@agora.org mmccracken@agora.org Attendee  
Molly Garczynski "8/24/21, 11:55:52 AM" "8/24/21, 2:01:05 PM" 2h 5m 12s  
mgarczynski@agora.org mgarczynski@agora.org Attendee  
Lisa Savitz "8/24/21, 11:55:55 AM" "8/24/21, 2:01:07 PM" 2h 5m 11s lsavitz@agora.org  
lsavitz@agora.org Attendee  
Jena Huffman "8/24/21, 11:56:08 AM" "8/24/21, 2:00:15 PM" 2h 4m 6s jhuffman@agora.org  
jhuffman@agora.org Attendee  
David Furka "8/24/21, 11:56:11 AM" "8/24/21, 2:01:40 PM" 2h 2m 55s dfurka@agora.org  
dfurka@agora.org Attendee  
Jenna Lee Dietrich "8/24/21, 11:56:12 AM" "8/24/21, 2:01:08 PM" 2h 4m 55s jdietrich@agora.org  
jdietrich@agora.org Attendee  
Melissa Stump "8/24/21, 11:56:17 AM" "8/24/21, 2:00:48 PM" 2h 4m 30s mstump@agora.org  
mstump@agora.org Attendee  
Brittany Froehlich "8/24/21, 11:56:21 AM" "8/24/21, 2:01:06 PM" 2h 4m 44s BFroehlich@agora.org  
BFroehlich@agora.org Attendee  
Melissa Love "8/24/21, 11:56:22 AM" "8/24/21, 1:58:38 PM" 2h 2m 16s mlove@agora.org  
mlove@agora.org Attendee  
Shannon Feeney Hoffmaster "8/24/21, 11:56:28 AM" "8/24/21, 2:01:06 PM" 2h 4m 38s  
shoffmaster@agora.org shoffmaster@agora.org Attendee  
Maria Harlan "8/24/21, 11:56:28 AM" "8/24/21, 2:00:50 PM" 1h 50m 52s mharlan@agora.org  
mharlan@agora.org Attendee  
Judy Deemer "8/24/21, 11:56:39 AM" "8/24/21, 2:00:57 PM" 2h 4m 17s jdeemer@agora.org  
jdeemer@agora.org Attendee  
Jill Moyer "8/24/21, 11:56:41 AM" "8/24/21, 2:00:59 PM" 2h 4m 18s jmoyer2@agora.org  
jmoyer2@agora.org Attendee  
Brianna Pontious "8/24/21, 11:56:47 AM" "8/24/21, 2:01:08 PM" 2h 4m 20s  
bpontious@agora.org bpontious@agora.org Attendee  
Heather Silberman "8/24/21, 11:56:53 AM" "8/24/21, 2:03:38 PM" 2h 4m 23s  
hsilberman@agora.org hsilberman@agora.org Attendee  
Leslie Spratt "8/24/21, 11:57:04 AM" "8/24/21, 2:01:36 PM" 2h 4m 31s lspratt@agora.org  
lspratt@agora.org Attendee  
Jennifer Cadieux "8/24/21, 11:57:07 AM" "8/24/21, 2:01:12 PM" 2h 4m 4s jcadieux@agora.org  
jcadieux@agora.org Attendee  
Lauren Svonavec "8/24/21, 11:57:18 AM" "8/24/21, 2:00:28 PM" 2h 3m 9s lsvonavec@agora.org  
lsvonavec@agora.org Attendee  
Morgan Witman "8/24/21, 11:57:21 AM" "8/24/21, 2:03:36 PM" 2h 6m 15s mwitman@agora.org  
mwitman@agora.org Organizer  
Shari Widlund "8/24/21, 11:57:26 AM" "8/24/21, 1:59:19 PM" 2h 1m 53s swidlund@agora.org  
swidlund@agora.org Attendee  
Jennifer Zollman "8/24/21, 11:57:33 AM" "8/24/21, 2:00:21 PM" 2h 2m 48s jzollman@agora.org  
jzollman@agora.org Attendee  
Kelly Berstecher "8/24/21, 11:57:46 AM" "8/24/21, 2:01:03 PM" 2h 3m 17s  
kberstecher@agora.org kberstecher@agora.org Attendee  
Michelle Pelissier "8/24/21, 11:57:49 AM" "8/24/21, 2:00:51 PM" 2h 1m 4s mpelissier@agora.org  
mpelissier@agora.org Attendee  
Veronica Jackson "8/24/21, 11:57:53 AM" "8/24/21, 2:01:35 PM" 2h 3m 42s vjackson@agora.org  
vjackson@agora.org Attendee  
Susan Lipiec "8/24/21, 11:57:56 AM" "8/24/21, 2:00:58 PM" 2h 3m 1s slipiec@agora.org  
slipiec@agora.org Attendee  
Heather Gallagher "8/24/21, 11:58:01 AM" "8/24/21, 2:00:10 PM" 2h 2m 9s  
hgallagher@agora.org hgallagher@agora.org Attendee  
Anna Baranoski "8/24/21, 11:58:01 AM" "8/24/21, 2:01:02 PM" 2h 3m 1s abaranoski@agora.org  
abaranoski@agora.org Attendee  
Lauren Lamison "8/24/21, 11:58:10 AM" "8/24/21, 2:00:46 PM" 2h 2m 35s llamison@agora.org  
llamison@agora.org Attendee

Janelle Shaffer "8/24/21, 11:58:17 AM" "8/24/21, 1:59:37 PM" 2h 1m 20s jshaffer3@agora.org  
jshaffer3@agora.org Attendee  
Cathryn Ramsey "8/24/21, 11:58:22 AM" "8/24/21, 2:00:52 PM" 1h 35m 38s cramsey@agora.org  
cramsey@agora.org Attendee  
Tara Walker "8/24/21, 11:58:24 AM" "8/24/21, 1:59:02 PM" 1h 56m twalker@agora.org  
twalker@agora.org Attendee  
Cortney Barkley "8/24/21, 11:58:26 AM" "8/24/21, 2:02:46 PM" 2h 4m 19s cbarkley@agora.org  
cbarkley@agora.org Attendee  
Erinn Slacktish "8/24/21, 11:58:32 AM" "8/24/21, 12:51:46 PM" 53m 13s eslacktish@agora.org  
eslacktish@agora.org Attendee  
Sabrina Kennedy "8/24/21, 11:58:47 AM" "8/24/21, 2:00:10 PM" 1h 48m 13s skennedy@agora.org  
skennedy@agora.org Attendee  
Amber Staley "8/24/21, 11:58:48 AM" "8/24/21, 2:00:09 PM" 2h 1m 20s astaley2@agora.org  
astaley2@agora.org Attendee  
Lauren Kerns "8/24/21, 11:58:49 AM" "8/24/21, 2:01:05 PM" 2h 2m 15s lkerns@agora.org  
lkerns@agora.org Attendee  
Theresa Draeger "8/24/21, 11:58:50 AM" "8/24/21, 2:01:22 PM" 2h 2m 32s tdraeger@agora.org  
tdraeger@agora.org Attendee  
Michelle Olsavsky "8/24/21, 11:58:52 AM" "8/24/21, 2:00:57 PM" 2h 2m 4s molsavsky@agora.org  
molsavsky@agora.org Attendee  
Brittany Kieffer "8/24/21, 11:58:53 AM" "8/24/21, 1:41:28 PM" 1h 30m 8s bkieffer@agora.org  
bkieffer@agora.org Attendee  
Christine Thomas "8/24/21, 11:58:55 AM" "8/24/21, 2:01:09 PM" 2h 2m 13s cthomas@agora.org  
cthomas@agora.org Attendee  
Laura Stapf "8/24/21, 11:58:59 AM" "8/24/21, 2:00:18 PM" 2h 1m 18s lstapf@agora.org  
lstapf@agora.org Attendee  
Jesse Capitano "8/24/21, 11:59:03 AM" "8/24/21, 2:00:58 PM" 2h 1m 55s jcapitano@agora.org  
jcapitano@agora.org Attendee  
Brittney Cantwell "8/24/21, 11:59:13 AM" "8/24/21, 2:00:46 PM" 2h 1m 33s bcantwell@agora.org  
bcantwell@agora.org Attendee  
Sasha Young "8/24/21, 11:59:16 AM" "8/24/21, 2:01:00 PM" 2h 1m 44s syoung@agora.org  
syoung@agora.org Attendee  
Kimberly Fiscus "8/24/21, 11:59:19 AM" "8/24/21, 2:01:05 PM" 2h 1m 46s kfiscus@agora.org  
kfiscus@agora.org Attendee  
Jessica Linderman "8/24/21, 11:59:21 AM" "8/24/21, 2:00:10 PM" 2h 49s jlinderman@agora.org  
jlinderman@agora.org Attendee  
Joseph Passante "8/24/21, 11:59:22 AM" "8/24/21, 1:18:49 PM" 1h 19m 27s jpassante@agora.org  
jpassante@agora.org Attendee  
Kaelyn Hoffman "8/24/21, 11:59:31 AM" "8/24/21, 2:01:01 PM" 2h 1m 30s khoffman@agora.org  
khoffman@agora.org Attendee  
Melanie Stanforth "8/24/21, 11:59:33 AM" "8/24/21, 2:01:03 PM" 1h 50m 49s  
mstanforth@agora.org mstanforth@agora.org Attendee  
Danielle Schall "8/24/21, 11:59:43 AM" "8/24/21, 2:01:04 PM" 1h 19m 37s dschall@agora.org  
dschall@agora.org Attendee  
Whitney Bargerstock "8/24/21, 11:59:44 AM" "8/24/21, 2:03:16 PM" 2h 3m 31s  
wbargerstock@agora.org wbargerstock@agora.org Presenter  
Samantha Bonniger "8/24/21, 11:59:52 AM" "8/24/21, 2:01:06 PM" 2h 1m 13s sbonniger@agora.org  
sbonniger@agora.org Attendee  
Lynn Pagliei "8/24/21, 11:59:58 AM" "8/24/21, 2:00:24 PM" 2h 25s lpagliei@agora.org  
lpagliei@agora.org Attendee  
Kymberly Humanick "8/24/21, 12:00:17 PM" "8/24/21, 2:01:05 PM" 2h 48s khumanick@agora.org  
khumanick@agora.org Attendee  
Julie Doebereiner "8/24/21, 12:00:18 PM" "8/24/21, 2:01:03 PM" 1h 58m 5s jdoebereiner@agora.org  
jdoebereiner@agora.org Attendee  
Amanda Kammermeier "8/24/21, 12:00:24 PM" "8/24/21, 2:01:13 PM" 2h 49s  
akammermeier@agora.org akammermeier@agora.org Attendee  
Melissa Hale-Patterson "8/24/21, 12:00:27 PM" "8/24/21, 2:01:00 PM" 2h 32s mpatterson@agora.org



mpatterson@agora.org	Attendee			
Amanda Armstrong	"8/24/21, 12:00:28 PM"	"8/24/21, 2:01:00 PM"	2h 32s	aarmstrong@agora.org
aarmstrong@agora.org	Attendee			
Nancy Reimers	"8/24/21, 12:00:28 PM"	"8/24/21, 1:57:43 PM"	1h 45m 32s	nreimers@agora.org
nreimers@agora.org	Attendee			
Nicole Krol	"8/24/21, 12:00:31 PM"	"8/24/21, 2:00:59 PM"	2h 27s	nkrol@agora.org nkrol@agora.org
Attendee				
Carissa Emrick	"8/24/21, 12:00:32 PM"	"8/24/21, 2:00:46 PM"	2h 13s	cemrick@agora.org
cemrick@agora.org	Attendee			
Angela Denham	"8/24/21, 12:00:33 PM"	"8/24/21, 2:01:00 PM"	2h 27s	adenham@agora.org
adenham@agora.org	Attendee			
Anna Lepsch	"8/24/21, 12:00:33 PM"	"8/24/21, 12:53:27 PM"	52m 53s	alepsch@agora.org
alepsch@agora.org	Attendee			
Rebekah Congdon	"8/24/21, 12:00:33 PM"	"8/25/21, 8:23:13 AM"	1h 56m 59s	
rcongdon@agora.org	rcongdon@agora.org	Attendee		
Lauren Radico	"8/24/21, 12:01:04 PM"	"8/24/21, 2:01:54 PM"	2h 50s	lradico@agora.org
lradico@agora.org	Attendee			
Valerie Natale	"8/24/21, 12:01:08 PM"	"8/24/21, 12:57:58 PM"	56m 50s	vnatale@agora.org
vnatale@agora.org	Attendee			
Gemma Mattox	"8/24/21, 12:01:09 PM"	"8/24/21, 2:01:02 PM"	1h 59m 53s	gmattox@agora.org
gmattox@agora.org	Attendee			
Chelsey Panchura	"8/24/21, 12:01:14 PM"	"8/24/21, 2:00:09 PM"	1h 58m 55s	
cpanchura@agora.org	cpanchura@agora.org	Attendee		
Jennifer DePietro	"8/24/21, 12:01:18 PM"	"8/24/21, 2:01:12 PM"	1h 59m 53s	
jdepietro@agora.org	jdepietro@agora.org	Attendee		
Amber Brisbane	"8/24/21, 12:01:55 PM"	"8/24/21, 2:00:59 PM"	1h 59m 4s	abrisbane@agora.org
abrisbane@agora.org	Attendee			
Breanne Scears	"8/24/21, 12:01:56 PM"	"8/24/21, 1:59:37 PM"	1h 57m 41s	bscears@agora.org
bscears@agora.org	Attendee			
Lisa Brestensky	"8/24/21, 12:02:07 PM"	"8/24/21, 2:00:57 PM"	1h 58m 50s	lbrestensky@agora.org
lbrestensky@agora.org	Attendee			
Kristina Lapsker	"8/24/21, 12:02:09 PM"	"8/24/21, 2:00:24 PM"	1h 58m 14s	klapsker@agora.org
klapsker@agora.org	Attendee			
Erin Scrip	"8/24/21, 12:02:16 PM"	"8/25/21, 9:19:31 AM"	21h 17m 14s	escrip@agora.org
escrip@agora.org	Attendee			
Tracey Ambuka	"8/24/21, 12:02:21 PM"	"8/24/21, 2:00:58 PM"	1h 58m 36s	tambuka@agora.org
tambuka@agora.org	Attendee			
Serena Adams	"8/24/21, 12:02:24 PM"	"8/24/21, 2:00:46 PM"	1h 58m 22s	sadams@agora.org
sadams@agora.org	Attendee			
Amy Raught	"8/24/21, 12:02:32 PM"	"8/24/21, 2:01:12 PM"	1h 58m 39s	araught@agora.org
araught@agora.org	Attendee			
Patrick Lavelle	"8/24/21, 12:02:37 PM"	"8/24/21, 2:00:03 PM"	1h 57m 26s	plavelle@agora.org
plavelle@agora.org	Attendee			
Stacy Vietmeier	"8/24/21, 12:02:40 PM"	"8/24/21, 2:01:07 PM"	1h 58m 27s	svietmeier@agora.org
svietmeier@agora.org	Attendee			
Shelley Stump	"8/24/21, 12:02:55 PM"	"8/24/21, 2:01:01 PM"	1h 58m 5s	sstump@agora.org
sstump@agora.org	Attendee			
Mindy Wesley	"8/24/21, 12:03:04 PM"	"8/24/21, 1:46:26 PM"	1h 43m 22s	mwesley@agora.org
mwesley@agora.org	Attendee			
Colleen Freyvogel Bruss	"8/24/21, 12:03:05 PM"	"8/24/21, 12:58:58 PM"	55m 53s	
cfreyvogel@agora.org	cfreyvogel@agora.org	Attendee		
Jill Severino	"8/24/21, 12:04:54 PM"	"8/24/21, 2:01:49 PM"	1h 56m 54s	jseverino@agora.org
jseverino@agora.org	Attendee			
Renee Perri	"8/24/21, 12:05:02 PM"	"8/24/21, 2:01:02 PM"	1h 55m 59s	rperri@agora.org
rperri@agora.org	Attendee			
Katie O'Donnell	"8/24/21, 12:06:55 PM"	"8/24/21, 1:59:34 PM"	1h 52m 38s	kodonnell@agora.org
kodonnell@agora.org	Attendee			

Jodeen Buckwalter	"8/24/21, 12:08:42 PM"	"8/24/21, 1:59:20 PM"	1h 50m 37s	j buckwalter@agora.org	j buckwalter@agora.org	Attendee
Heidi Dodge	"8/24/21, 12:09:45 PM"	"8/24/21, 2:01:06 PM"	1h 51m 20s	hdodge@agora.org	hdodge@agora.org	Attendee
Dana Pacolay	"8/24/21, 12:11:55 PM"	"8/24/21, 1:59:50 PM"	1h 47m 55s	dpacolay@agora.org	dpacolay@agora.org	Attendee
Jessica Barnhart	"8/24/21, 12:27:07 PM"	"8/24/21, 2:01:08 PM"	1h 34m 1s	jbarnhart@agora.org	jbarnhart@agora.org	Attendee
Melissa Gaso	"8/24/21, 12:28:09 PM"	"8/24/21, 1:59:06 PM"	1h 30m 57s	mgaso@agora.org	mgaso@agora.org	Attendee
Jennifer Fisher Clark	"8/24/21, 12:37:08 PM"	"8/24/21, 12:59:41 PM"	22m 33s	jclark@agora.org	jclark@agora.org	Attendee
Jen Lucia	"8/24/21, 12:37:11 PM"	"8/24/21, 12:59:11 PM"	22m	jlucia@agora.org	jlucia@agora.org	Attendee
Maryann Johnson	"8/24/21, 12:52:55 PM"	"8/24/21, 12:57:58 PM"	5m 3s	majohnson@agora.org	majohnson@agora.org	Attendee
Maura Basso	"8/24/21, 1:13:58 PM"	"8/24/21, 2:35:22 PM"	1h 21m 23s	mbasso@agora.org	mbasso@agora.org	Attendee

### 3. In-Meeting activities

Name	Join time	Leave time	Duration	Email	Role
Cathryn Mack	"8/24/21, 11:46:01 AM"	"8/24/21, 2:01:33 PM"	2h 15m 32s	cmack@agora.org	Attendee
Kimberly McLaughlin	"8/24/21, 11:46:19 AM"	"8/24/21, 12:53:27 PM"	1h 7m 8s	kmclaughlin@agora.org	Attendee
Susan Lelko	"8/24/21, 11:46:21 AM"	"8/24/21, 1:01:39 PM"	1h 15m 17s	slelko@agora.org	Attendee
Susan Lelko	"8/24/21, 1:03:06 PM"	"8/24/21, 1:59:06 PM"	55m 59s	slelko@agora.org	Attendee
Brett Stevens	"8/24/21, 11:46:22 AM"	"8/24/21, 2:01:02 PM"	2h 14m 40s	bstevens2@agora.org	Attendee
Chris Baker	"8/24/21, 11:48:21 AM"	"8/24/21, 11:48:48 AM"	27s	cbaker@agora.org	Attendee
Chris Baker	"8/24/21, 12:03:48 PM"	"8/24/21, 2:01:14 PM"	1h 57m 25s	cbaker@agora.org	Attendee
Tamara Kozak	"8/24/21, 11:48:56 AM"	"8/24/21, 2:00:07 PM"	2h 11m 11s	tkozak@agora.org	Attendee
Barb Cooper	"8/24/21, 11:49:05 AM"	"8/24/21, 2:00:59 PM"	2h 11m 53s	bcooper@agora.org	Attendee
Joy Fegely	"8/24/21, 11:49:59 AM"	"8/24/21, 2:01:03 PM"	2h 11m 4s	jfegely@agora.org	Attendee
Colien Byers	"8/24/21, 11:50:17 AM"	"8/24/21, 2:00:16 PM"	2h 9m 59s	cbyers@agora.org	Attendee
Amanda Moyer	"8/24/21, 11:50:42 AM"	"8/24/21, 2:00:14 PM"	2h 9m 32s	amoyer@agora.org	Attendee
Jennifer Flatley	"8/24/21, 11:50:50 AM"	"8/24/21, 1:59:09 PM"	2h 8m 18s	jflatley@agora.org	Attendee
Bridget Ellis	"8/24/21, 11:51:22 AM"	"8/24/21, 2:01:06 PM"	2h 9m 43s	bellis@agora.org	Attendee
Allison Large	"8/24/21, 11:51:32 AM"	"8/24/21, 1:59:15 PM"	2h 7m 43s	alarge@agora.org	Attendee
Kristy Welsh	"8/24/21, 11:51:33 AM"	"8/24/21, 1:59:12 PM"	2h 7m 39s	kwelsh@agora.org	Attendee
Theresa Bash	"8/24/21, 11:51:41 AM"	"8/24/21, 2:00:56 PM"	2h 9m 15s	tbash@agora.org	Attendee
Regina Kubica	"8/24/21, 11:52:03 AM"	"8/24/21, 1:58:00 PM"	2h 5m 56s	rkubica@agora.org	Attendee
Kimberly Paolino	"8/24/21, 11:52:53 AM"	"8/24/21, 2:00:24 PM"	2h 7m 31s	kpaolino@agora.org	Attendee
Terri Hunkele	"8/24/21, 11:53:14 AM"	"8/24/21, 1:59:41 PM"	2h 6m 27s	thunkele@agora.org	Attendee

Attendee  
Kattreena Amodeo "8/24/21, 11:54:07 AM" "8/24/21, 2:00:32 PM"2h 6m 25s kamodeo@agora.org  
Attendee  
Rachel Carmichael "8/24/21, 11:54:13 AM" "8/24/21, 2:01:12 PM"2h 6m 58s rcarmichael@agora.org  
Attendee  
Brittany Reamer "8/24/21, 11:54:19 AM" "8/24/21, 2:00:54 PM"2h 6m 34s breamer@agora.org  
Attendee  
Jennifer Beeken "8/24/21, 11:54:33 AM" "8/24/21, 2:01:12 PM"2h 6m 38s jbeeken@agora.org  
Attendee  
Kristal Costanzo "8/24/21, 11:54:37 AM" "8/24/21, 12:50:03 PM" 55m 25s kcostanzo@agora.org  
Attendee  
Kristal Costanzo "8/24/21, 12:57:28 PM" "8/24/21, 2:01:14 PM"1h 3m 45s kcostanzo@agora.org  
Attendee  
Danielle Pricer "8/24/21, 11:55:10 AM" "8/24/21, 1:03:54 PM"1h 8m 44s dpricer@agora.org  
Attendee  
Danielle Pricer "8/24/21, 1:09:07 PM""8/24/21, 1:17:25 PM"8m 18s dpricer@agora.org Attendee  
Melissa McCracken "8/24/21, 11:55:14 AM" "8/24/21, 12:16:01 PM" 20m 46s  
mmccracken@agora.org Attendee  
Melissa McCracken "8/24/21, 12:20:25 PM" "8/24/21, 2:00:52 PM"1h 40m 26s  
mmccracken@agora.org Attendee  
Molly Garczynski "8/24/21, 11:55:52 AM" "8/24/21, 2:01:05 PM"2h 5m 12s mgarczynski@agora.org  
Attendee  
Lisa Savitz "8/24/21, 11:55:55 AM" "8/24/21, 2:01:07 PM"2h 5m 11s lsavitz@agora.org Attendee  
Jena Huffman "8/24/21, 11:56:08 AM" "8/24/21, 2:00:15 PM"2h 4m 6s jhuffman@agora.org  
Attendee  
David Furka "8/24/21, 11:56:11 AM" "8/24/21, 1:09:01 PM"1h 12m 50s dfurka@agora.org  
Attendee  
David Furka "8/24/21, 1:11:35 PM""8/24/21, 2:01:40 PM"50m 5s dfurka@agora.org Attendee  
Jenna Lee Dietrich "8/24/21, 11:56:12 AM" "8/24/21, 2:01:08 PM"2h 4m 55s jdietrich@agora.org  
Attendee  
Melissa Stump "8/24/21, 11:56:17 AM" "8/24/21, 2:00:48 PM"2h 4m 30s mstump@agora.org  
Attendee  
Brittany Froehlich "8/24/21, 11:56:21 AM" "8/24/21, 2:01:06 PM"2h 4m 44s BFroehlich@agora.org  
Attendee  
Melissa Love "8/24/21, 11:56:22 AM" "8/24/21, 1:58:38 PM"2h 2m 16s mlove@agora.org  
Attendee  
Shannon Feeney Hoffmaster "8/24/21, 11:56:28 AM" "8/24/21, 2:01:06 PM"2h 4m 38s  
shoffmaster@agora.org Attendee  
Maria Harlan "8/24/21, 11:56:28 AM" "8/24/21, 1:15:04 PM"1h 18m 35s mharlan@agora.org  
Attendee  
Maria Harlan "8/24/21, 1:28:32 PM""8/24/21, 2:00:50 PM"32m 17s mharlan@agora.org Attendee  
Judy Deemer "8/24/21, 11:56:39 AM" "8/24/21, 2:00:57 PM"2h 4m 17s jdeemer@agora.org  
Attendee  
Jill Moyer "8/24/21, 11:56:41 AM" "8/24/21, 2:00:59 PM"2h 4m 18s jmoyer2@agora.org Attendee  
Brianna Pontious"8/24/21, 11:56:47 AM" "8/24/21, 2:01:08 PM"2h 4m 20s bpontious@agora.org  
Attendee  
Heather Silberman "8/24/21, 11:56:53 AM" "8/24/21, 2:01:08 PM"2h 4m 15s hsilberman@agora.org  
Attendee  
Heather Silberman "8/24/21, 2:03:30 PM""8/24/21, 2:03:38 PM"8s hsilberman@agora.orgAttendee  
Leslie Spratt "8/24/21, 11:57:04 AM" "8/24/21, 2:01:36 PM"2h 4m 31s lspratt@agora.org  
Attendee  
Jennifer Cadieux "8/24/21, 11:57:07 AM" "8/24/21, 2:01:12 PM"2h 4m 4s jcadieux@agora.org  
Attendee  
Lauren Svonavec "8/24/21, 11:57:18 AM" "8/24/21, 2:00:28 PM"2h 3m 9s lsvonavec@agora.org  
Attendee  
Morgan Witman "8/24/21, 11:57:21 AM" "8/24/21, 2:03:36 PM"2h 6m 15s mwitman@agora.org  
Organizer

Shari Widlund Attendee	"8/24/21, 11:57:26 AM"	"8/24/21, 1:59:19 PM"2h 1m 53s	swidlund@agora.org
Jennifer Zollman Attendee	"8/24/21, 11:57:33 AM"	"8/24/21, 2:00:21 PM"2h 2m 48s	jzollman@agora.org
Kelly Berstecher Attendee	"8/24/21, 11:57:46 AM"	"8/24/21, 2:01:03 PM"2h 3m 17s	kberstecher@agora.org
Michelle Pelissier Attendee	"8/24/21, 11:57:49 AM"	"8/24/21, 1:01:16 PM"1h 3m 27s	mpelissier@agora.org
Michelle Pelissier Attendee	"8/24/21, 1:03:14 PM"	"8/24/21, 2:00:51 PM"57m 37s	mpelissier@agora.org
Veronica Jackson Attendee	"8/24/21, 11:57:53 AM"	"8/24/21, 2:01:35 PM"2h 3m 42s	vjackson@agora.org
Susan Lipiec Attendee	"8/24/21, 11:57:56 AM"	"8/24/21, 2:00:58 PM"2h 3m 1s	slipiec@agora.org
Heather Gallagher Attendee	"8/24/21, 11:58:01 AM"	"8/24/21, 2:00:10 PM"2h 2m 9s	hgallagher@agora.org
Anna Baranoski Attendee	"8/24/21, 11:58:01 AM"	"8/24/21, 2:01:02 PM"2h 3m 1s	abaranoski@agora.org
Lauren Lamison Attendee	"8/24/21, 11:58:10 AM"	"8/24/21, 2:00:46 PM"2h 2m 35s	llamison@agora.org
Janelle Shaffer Attendee	"8/24/21, 11:58:17 AM"	"8/24/21, 1:59:37 PM"2h 1m 20s	jshaffer3@agora.org
Cathryn Ramsey Attendee	"8/24/21, 11:58:22 AM"	"8/24/21, 12:03:10 PM" 4m 48s	cramsey@agora.org
Cathryn Ramsey Attendee	"8/24/21, 12:30:02 PM"	"8/24/21, 2:00:52 PM"1h 30m 50s	cramsey@agora.org
Tara Walker Attendee	"8/24/21, 11:58:24 AM"	"8/24/21, 1:51:40 PM"1h 53m 15s	twalker@agora.org
Tara Walker Attendee	"8/24/21, 1:56:17 PM"	"8/24/21, 1:59:02 PM"2m 45s	twalker@agora.org
Cortney Barkley Attendee	"8/24/21, 11:58:26 AM"	"8/24/21, 2:02:46 PM"2h 4m 19s	cbarkley@agora.org
Erinn Slacktish Attendee	"8/24/21, 11:58:32 AM"	"8/24/21, 12:51:46 PM" 53m 13s	eslacktish@agora.org
Sabrina Kennedy Attendee	"8/24/21, 11:58:47 AM"	"8/24/21, 12:19:01 PM" 20m 13s	skennedy@agora.org
Sabrina Kennedy Attendee	"8/24/21, 12:32:10 PM"	"8/24/21, 2:00:10 PM"1h 28m	skennedy@agora.org
Amber Staley Attendee	"8/24/21, 11:58:48 AM"	"8/24/21, 2:00:09 PM"2h 1m 20s	astaley2@agora.org
Lauren Kerns Attendee	"8/24/21, 11:58:49 AM"	"8/24/21, 2:01:05 PM"2h 2m 15s	lkerns@agora.org
Theresa Draeger Attendee	"8/24/21, 11:58:50 AM"	"8/24/21, 2:01:22 PM"2h 2m 32s	tdraeger@agora.org
Michelle Olsavsky Attendee	"8/24/21, 11:58:52 AM"	"8/24/21, 2:00:57 PM"2h 2m 4s	molsavsky@agora.org
Brittany Kieffer Attendee	"8/24/21, 11:58:53 AM"	"8/24/21, 12:09:17 PM" 10m 24s	bkieffer@agora.org
Brittany Kieffer Attendee	"8/24/21, 12:12:05 PM"	"8/24/21, 12:30:08 PM" 18m 3s	bkieffer@agora.org
Brittany Kieffer Attendee	"8/24/21, 12:36:40 PM"	"8/24/21, 12:42:32 PM" 5m 51s	bkieffer@agora.org
Brittany Kieffer Attendee	"8/24/21, 12:45:37 PM"	"8/24/21, 1:41:28 PM"55m 50s	bkieffer@agora.org
Christine Thomas Attendee	"8/24/21, 11:58:55 AM"	"8/24/21, 2:01:09 PM"2h 2m 13s	cthomas@agora.org
Laura Stapf Attendee	"8/24/21, 11:58:59 AM"	"8/24/21, 2:00:18 PM"2h 1m 18s	lstapf@agora.org
Jesse Capitano Attendee	"8/24/21, 11:59:03 AM"	"8/24/21, 2:00:58 PM"2h 1m 55s	jcapitano@agora.org

Attendee  
 Brittney Cantwell "8/24/21, 11:59:13 AM" "8/24/21, 2:00:46 PM" 2h 1m 33s bcantwell@agora.org  
 Attendee  
 Sasha Young "8/24/21, 11:59:16 AM" "8/24/21, 2:01:00 PM" 2h 1m 44s syoung@agora.org  
 Attendee  
 Kimberly Fiscus "8/24/21, 11:59:19 AM" "8/24/21, 2:01:05 PM" 2h 1m 46s kfiscus@agora.org  
 Attendee  
 Jessica Linderman "8/24/21, 11:59:21 AM" "8/24/21, 2:00:10 PM" 2h 49s jlinderman@agora.org  
 Attendee  
 Joseph Passante "8/24/21, 11:59:22 AM" "8/24/21, 1:18:49 PM" 1h 19m 27s jpassante@agora.org  
 Attendee  
 Kaelyn Hoffman "8/24/21, 11:59:31 AM" "8/24/21, 2:01:01 PM" 2h 1m 30s khoffman@agora.org  
 Attendee  
 Melanie Stanforth "8/24/21, 11:59:33 AM" "8/24/21, 1:46:20 PM" 1h 46m 47s  
 mstanforth@agora.org Attendee  
 Melanie Stanforth "8/24/21, 1:57:00 PM" "8/24/21, 2:01:03 PM" 4m 2s mstanforth@agora.org  
 Attendee  
 Danielle Schall "8/24/21, 11:59:43 AM" "8/24/21, 12:57:44 PM" 58m 1s dschall@agora.org  
 Attendee  
 Danielle Schall "8/24/21, 1:39:27 PM" "8/24/21, 2:01:04 PM" 21m 36s dschall@agora.org Attendee  
 Whitney Bargerstock "8/24/21, 11:59:44 AM" "8/24/21, 2:03:16 PM" 2h 3m 31s  
 wbargerstock@agora.org Presenter  
 Samantha Bonniger "8/24/21, 11:59:52 AM" "8/24/21, 2:01:06 PM" 2h 1m 13s sbonniger@agora.org  
 Attendee  
 Lynn Pagliei "8/24/21, 11:59:58 AM" "8/24/21, 2:00:24 PM" 2h 25s lpagliei@agora.org  
 Attendee  
 Kymberly Humanick "8/24/21, 12:00:17 PM" "8/24/21, 2:01:05 PM" 2h 48s khumanick@agora.org  
 Attendee  
 Julie Doebereiner "8/24/21, 12:00:18 PM" "8/24/21, 1:44:13 PM" 1h 43m 55s  
 jdoebereiner@agora.org Attendee  
 Julie Doebereiner "8/24/21, 1:46:52 PM" "8/24/21, 2:01:03 PM" 14m 10s jdoebereiner@agora.org  
 Attendee  
 Amanda Kammermeier "8/24/21, 12:00:24 PM" "8/24/21, 2:01:13 PM" 2h 49s  
 akammermeier@agora.org Attendee  
 Melissa Hale-Patterson "8/24/21, 12:00:27 PM" "8/24/21, 2:01:00 PM" 2h 32s mpatterson@agora.org  
 Attendee  
 Amanda Armstrong "8/24/21, 12:00:28 PM" "8/24/21, 2:01:00 PM" 2h 32s aarmstrong@agora.org  
 Attendee  
 Nancy Reimers "8/24/21, 12:00:28 PM" "8/24/21, 12:27:29 PM" 27m nreimers@agora.org  
 Attendee  
 Nancy Reimers "8/24/21, 12:39:10 PM" "8/24/21, 1:57:43 PM" 1h 18m 32s nreimers@agora.org  
 Attendee  
 Nicole Krol "8/24/21, 12:00:31 PM" "8/24/21, 2:00:59 PM" 2h 27s nkrol@agora.org Attendee  
 Carissa Emrick "8/24/21, 12:00:32 PM" "8/24/21, 2:00:46 PM" 2h 13s cemrick@agora.org  
 Attendee  
 Angela Denham "8/24/21, 12:00:33 PM" "8/24/21, 2:01:00 PM" 2h 27s adenham@agora.org  
 Attendee  
 Anna Lepsch "8/24/21, 12:00:33 PM" "8/24/21, 12:53:27 PM" 52m 53s alepsch@agora.org  
 Attendee  
 Rebekah Congdon "8/24/21, 12:00:33 PM" "8/24/21, 12:19:15 PM" 18m 42s  
 rcongdon@agora.org Attendee  
 Rebekah Congdon "8/24/21, 12:22:50 PM" "8/24/21, 2:00:39 PM" 1h 37m 49s  
 rcongdon@agora.org Attendee  
 Rebekah Congdon "8/25/21, 8:22:45 AM" "8/25/21, 8:23:13 AM" 28s rcongdon@agora.org  
 Attendee  
 Lauren Radico "8/24/21, 12:01:04 PM" "8/24/21, 2:01:54 PM" 2h 50s lradico@agora.org  
 Attendee

Valerie Natale Attendee	"8/24/21, 12:01:08 PM"	"8/24/21, 12:57:58 PM"	56m 50s	vnatale@agora.org
Gemma Mattox Attendee	"8/24/21, 12:01:09 PM"	"8/24/21, 2:01:02 PM"	1h 59m 53s	gmattox@agora.org
Chelsey Panchura cpanchura@agora.org Attendee	"8/24/21, 12:01:14 PM"	"8/24/21, 2:00:09 PM"	1h 58m 55s	
Jennifer DePietro jdepietro@agora.org Attendee	"8/24/21, 12:01:18 PM"	"8/24/21, 2:01:12 PM"	1h 59m 53s	
Amber Brisbane Attendee	"8/24/21, 12:01:55 PM"	"8/24/21, 2:00:59 PM"	1h 59m 4s	abrisbane@agora.org
Breanne Scears Attendee	"8/24/21, 12:01:56 PM"	"8/24/21, 1:59:37 PM"	1h 57m 41s	bscears@agora.org
Lisa Brestensky Attendee	"8/24/21, 12:02:07 PM"	"8/24/21, 2:00:57 PM"	1h 58m 50s	lbrestensky@agora.org
Kristina Lapsker Attendee	"8/24/21, 12:02:09 PM"	"8/24/21, 2:00:24 PM"	1h 58m 14s	klapsker@agora.org
Erin Scrip Attendee	"8/24/21, 12:02:16 PM"	"8/25/21, 9:19:31 AM"	21h 17m 14s	escrip@agora.org
Tracey Ambuka Attendee	"8/24/21, 12:02:21 PM"	"8/24/21, 2:00:58 PM"	1h 58m 36s	tambuka@agora.org
Serena Adams Attendee	"8/24/21, 12:02:24 PM"	"8/24/21, 2:00:46 PM"	1h 58m 22s	sadams@agora.org
Amy Raught Attendee	"8/24/21, 12:02:32 PM"	"8/24/21, 2:01:12 PM"	1h 58m 39s	araught@agora.org
Patrick Lavelle Attendee	"8/24/21, 12:02:37 PM"	"8/24/21, 2:00:03 PM"	1h 57m 26s	plavelle@agora.org
Stacy Vietmeier Attendee	"8/24/21, 12:02:40 PM"	"8/24/21, 2:01:07 PM"	1h 58m 27s	svietmeier@agora.org
Shelley Stump Attendee	"8/24/21, 12:02:55 PM"	"8/24/21, 2:01:01 PM"	1h 58m 5s	sstump@agora.org
Mindy Wesley Attendee	"8/24/21, 12:03:04 PM"	"8/24/21, 1:46:26 PM"	1h 43m 22s	mwesley@agora.org
Colleen Freyvogel Bruss cfreyvogel@agora.org Attendee	"8/24/21, 12:03:05 PM"	"8/24/21, 12:58:58 PM"	55m 53s	
Jill Severino Attendee	"8/24/21, 12:04:54 PM"	"8/24/21, 2:01:49 PM"	1h 56m 54s	jseverino@agora.org
Renee Perri Attendee	"8/24/21, 12:05:02 PM"	"8/24/21, 2:01:02 PM"	1h 55m 59s	rperri@agora.org
Katie O'Donnell Attendee	"8/24/21, 12:06:55 PM"	"8/24/21, 1:59:34 PM"	1h 52m 38s	kodonnell@agora.org
Jodeen Buckwalter jbuckwalter@agora.org Attendee	"8/24/21, 12:08:42 PM"	"8/24/21, 1:59:20 PM"	1h 50m 37s	
Heidi Dodge Attendee	"8/24/21, 12:09:45 PM"	"8/24/21, 2:01:06 PM"	1h 51m 20s	hdodge@agora.org
Dana Pacolay Attendee	"8/24/21, 12:11:55 PM"	"8/24/21, 1:59:50 PM"	1h 47m 55s	dpacolay@agora.org
Jessica Barnhart Attendee	"8/24/21, 12:27:07 PM"	"8/24/21, 2:01:08 PM"	1h 34m 1s	jbarnhart@agora.org
Melissa Gaso Attendee	"8/24/21, 12:28:09 PM"	"8/24/21, 1:59:06 PM"	1h 30m 57s	mgaso@agora.org
Jennifer Fisher Clark Attendee	"8/24/21, 12:37:08 PM"	"8/24/21, 12:59:41 PM"	22m 33s	jclark@agora.org
Jen Lucia Attendee	"8/24/21, 12:37:11 PM"	"8/24/21, 12:59:11 PM"	22m	jlucia@agora.org
Maryann Johnson majohnson@agora.org Attendee	"8/24/21, 12:52:55 PM"	"8/24/21, 12:57:58 PM"	5m 3s	
Maura Basso Attendee	"8/24/21, 1:13:58 PM"	"8/24/21, 2:35:22 PM"	1h 21m 23s	mbasso@agora.org

# Push in Support Teacher

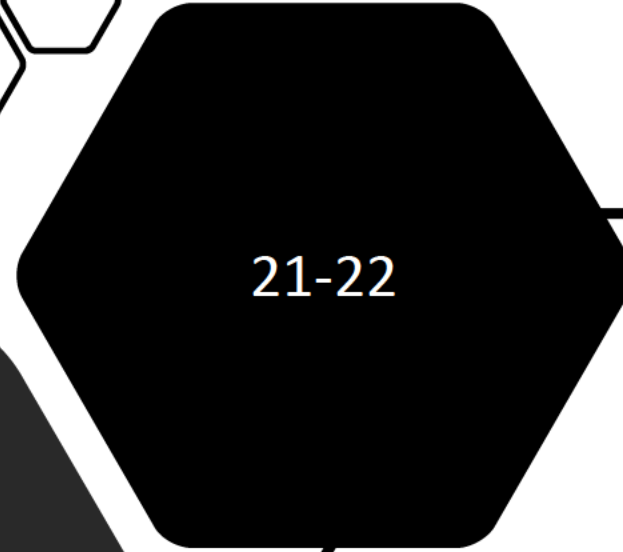
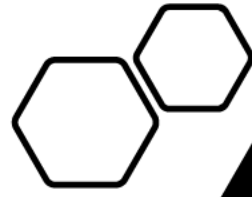

21-22

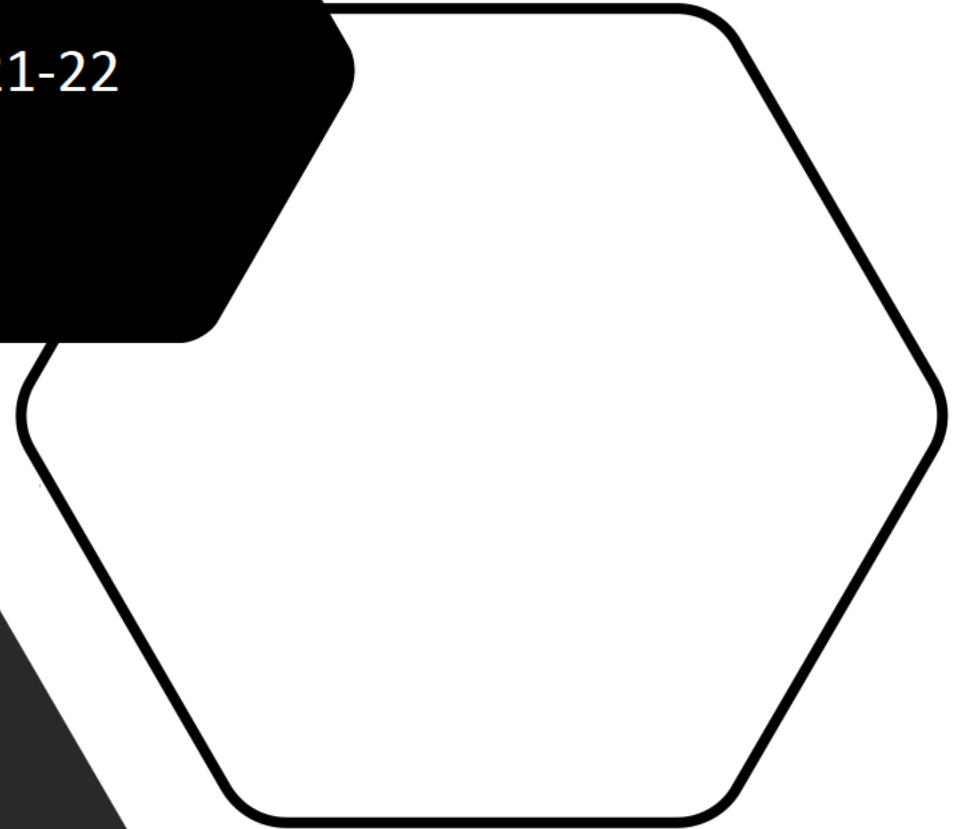

# Intentions

To allow time in the special ed teachers schedule to be able to work with their roster of students on IEP goal skills.

To provide more freedom with where you go to support students when they need it.

To provide more opportunities for collaboration between General and Special education teachers, providing more ownership of support for the General Ed teachers.



More time to work with students on  
Math and ELA goals!!

What is  
working?

# What isn't working?

- The current schedule only allows you to push in during certain times in the classes. It has been during direct instruction times, which doesn't allow for the opportunities to push into the classroom and support the students.

What ideas  
do you have  
for improving  
it for this  
year?

# Ideas that we came up with:

Target special ed students who are behind in assignments & help them complete them.

Send “to do” or “catch up” lists to student/parent/PCA of owed work.

## Assist with TDA's

Provide Mods/Accom to Sci/History class. Meet in advance with Gen ed to know what material/concepts are coming up. Look at students Sdi's & their needs. Provide modifications to the Gen Ed teacher to use with students



Thoughts?  
Ideas?  
Suggestions?

## 1. Summary

Attended participants 7

Start time "2/10/22, 10:55:55 AM"

End time "2/10/22, 12:13:51 PM"

Meeting duration 1h 17m 56s

Average attendance time 53m 35s

## 2. Participants

Name	First join	Last leave	In-meeting duration	Email	Participant ID (UPN)	Role
Stefanie Marcello	"2/10/22, 10:56:01 AM"	"2/10/22, 11:59:36 AM"	1h 3m 35s	smarcello@agora.org	smarcello@agora.org	Presenter
Stephanie Mannarino	"2/10/22, 10:57:21 AM"	"2/10/22, 11:59:38 AM"	1h 2m 17s	smannarino@agora.org	smannarino@agora.org	Presenter
Regina Mallon	"2/10/22, 10:57:27 AM"	"2/10/22, 12:13:48 PM"	1h 16m 21s	gmallon@agora.org	gmallon@agora.org	Presenter
Casey Chaffin	"2/10/22, 10:58:59 AM"	"2/10/22, 11:59:36 AM"	1h 37s	cchaffin@agora.org	cchaffin@agora.org	Presenter
Michelle Cukauskas	"2/10/22, 10:59:24 AM"	"2/10/22, 12:13:51 PM"	1h 14m 26s	mcukauskas@agora.org	mcukauskas@agora.org	Organizer
Laurie Super	"2/10/22, 11:27:58 AM"	"2/10/22, 11:59:36 AM"	31m 37s	lsuper@agora.org	lsuper@agora.org	Presenter
Melissa Franklin	"2/10/22, 11:53:30 AM"	"2/10/22, 11:59:41 AM"	6m 10s	mfranklin@agora.org	mfranklin@agora.org	Presenter

## 3. In-Meeting activities

Name	Join time	Leave time	Duration	Email	Role
Stefanie Marcello	"2/10/22, 10:56:01 AM"	"2/10/22, 11:59:36 AM"	1h 3m 35s	smarcello@agora.org	Presenter
Stephanie Mannarino	"2/10/22, 10:57:21 AM"	"2/10/22, 11:59:38 AM"	1h 2m 17s	smannarino@agora.org	Presenter
Regina Mallon	"2/10/22, 10:57:27 AM"	"2/10/22, 12:13:48 PM"	1h 16m 21s	gmallon@agora.org	Presenter
Casey Chaffin	"2/10/22, 10:58:59 AM"	"2/10/22, 11:59:36 AM"	1h 37s	cchaffin@agora.org	Presenter
Michelle Cukauskas	"2/10/22, 10:59:24 AM"	"2/10/22, 12:13:51 PM"	1h 14m 26s	mcukauskas@agora.org	Organizer
Laurie Super	"2/10/22, 11:27:58 AM"	"2/10/22, 11:59:36 AM"	31m 37s	lsuper@agora.org	Presenter
Melissa Franklin	"2/10/22, 11:53:30 AM"	"2/10/22, 11:59:41 AM"	6m 10s	mfranklin@agora.org	Presenter

# Agenda

- A Big Thank You
- Meet your ESY ADs
- What Can you Expect from your ESY ADs
- Duties & Responsibilities
- Substitute Information
- Timesheet Information
- Crisis Information
- ESY Folder 2022 and Essential Reminders
- Q&A

Please take note of any questions and save them for the end.



Event Title: ESY Case Manager Training													
Location: <a href="https://nam02.safelinks.protection.outlook.com/ap/t-59584e83/?url=https%3A%2F%2Fteams.microsoft.com%2F%2Fmeetup-join%2F19%253ameeting_YjQ5MWFhOWYtOWNjZi00MGU1LWE4NzYtZWUxOGUzNDA0N2Rh%2540thread.v2%2F0%3Fcontext%3D%257b%2522Tid%2522%253a%25221daf2f11-55f3-4b9b-b249-e66cb7cbbc22%2522%252c%2522Oid%2522%253a%2522c9bd3829-954d-4f76-a901-0f535c7fa941%2522%257d&amp;data=05%7C01%7Cvntale%40agora.org%7Caaf59e9524424b2809c208da3cfc7725%7C1daf2f1155f34b9bb249e66cb7cbbc22%7C0%7C0%7C637889352270479327%7CUnknown%7CTWFpbGZs">https://nam02.safelinks.protection.outlook.com/ap/t-59584e83/?url=https%3A%2F%2Fteams.microsoft.com%2F%2Fmeetup-join%2F19%253ameeting_YjQ5MWFhOWYtOWNjZi00MGU1LWE4NzYtZWUxOGUzNDA0N2Rh%2540thread.v2%2F0%3Fcontext%3D%257b%2522Tid%2522%253a%25221daf2f11-55f3-4b9b-b249-e66cb7cbbc22%2522%252c%2522Oid%2522%253a%2522c9bd3829-954d-4f76-a901-0f535c7fa941%2522%257d&amp;data=05%7C01%7Cvntale%40agora.org%7Caaf59e9524424b2809c208da3cfc7725%7C1daf2f1155f34b9bb249e66cb7cbbc22%7C0%7C0%7C637889352270479327%7CUnknown%7CTWFpbGZs</a>													
Start Date: 06/07/2022 3:00 PM													
<b>SLOT - 06/07/2022 3:00 PM</b>													
Educator First Name	Educator Last Name	Educator Local ID	Educator School	Presenter	Status	Signup Date	Waitlist Date	Hrs	Signed In	Approval	Credits Released	Comment	User Id
Christian	Baker	6760832	Middle School	Valerie Natale, Maryann Johnson	Approved	05/25/2022 9:08 AM		1.0	No	06/08/2022	No		720525
Theresa	Bash	1653853	Middle School	Valerie Natale, Maryann Johnson	Approved	05/25/2022 9:08 AM		1.0	No	06/08/2022	No		720395
Nicole	Chiado		Elementary School	Valerie Natale, Maryann Johnson	Approved	05/25/2022 9:08 AM		1.0	No	06/08/2022	No		916069
Meredith	Conway	9384068	Elementary School	Valerie Natale, Maryann Johnson	Approved	05/25/2022 9:08 AM		1.0	No	06/08/2022	No		720457
Jennifer	Fisher-Clark	8961729	Middle School	Valerie Natale, Maryann Johnson	Approved	05/25/2022 9:08 AM		1.0	No	06/08/2022	No		720404
David	Furka	5839145	Middle School	Valerie Natale, Maryann Johnson	Approved	05/25/2022 9:08 AM		1.0	No	06/08/2022	No		720587
Maria	Harlan	8209824	K-8	Valerie Natale, Maryann Johnson	Approved	05/25/2022 9:08 AM		1.0	No	06/08/2022	No		720797
Robin	Hartman	7359613	Elementary School	Valerie Natale, Maryann Johnson	Approved	05/25/2022 9:08 AM		1.0	No	06/08/2022	No		720620
Melanie	Hathaway	7142391	Middle School	Valerie Natale, Maryann Johnson	Approved	05/25/2022 9:08 AM		1.0	No	06/08/2022	No		720545
Maryann	Johnson	9682934	K-8	Valerie Natale, Maryann Johnson	Approved	05/25/2022 9:08 AM		1.0	No	06/08/2022	No		720459
Margret	Joseph		Elementary School	Valerie Natale, Maryann Johnson	Approved	05/25/2022 9:08 AM		1.0	No	06/08/2022	No		914487
Rebecca	Kenzakowski	8947597	High School	Valerie Natale, Maryann Johnson	Approved	05/25/2022 9:08 AM		1.0	No	06/08/2022	No		720311
Kristina	Lapsker	9379892	Elementary School	Valerie Natale, Maryann Johnson	Approved	05/25/2022 9:08 AM		1.0	No	06/08/2022	No		720599
Susan	Lipiec	7462653	Middle School	Valerie Natale, Maryann Johnson	Approved	05/25/2022 9:08 AM		1.0	No	06/08/2022	No		720820
Cathryn	Mack	9457194	K-8	Valerie Natale, Maryann Johnson	Approved	05/25/2022 9:08 AM		1.0	No	06/08/2022	No		720601
Valerie	Natale	1786193	High School	Valerie Natale, Maryann Johnson	Approved	05/25/2022 9:08 AM		1.0	No	06/08/2022	No		720678
Stephen	Nugent	5398423	High School	Valerie Natale, Maryann Johnson	Approved	05/25/2022 9:08 AM		1.0	No	06/08/2022	No		720735
Lynn	Pagliei	3109573	High School	Valerie Natale, Maryann Johnson	Approved	05/25/2022 9:08 AM		1.0	No	06/08/2022	No		720608
Michelle	Pelissier	1391528	K-8	Valerie Natale, Maryann Johnson	Approved	05/25/2022 9:08 AM		1.0	No	06/08/2022	No		720394
Amy	Raught	4603802	High School	Valerie Natale, Maryann Johnson	Approved	05/25/2022 9:08 AM		1.0	No	06/08/2022	No		720390
Carmen	Riggle	9076017	Elementary School	Valerie Natale, Maryann Johnson	Approved	05/25/2022 9:08 AM		1.0	No	06/08/2022	No		720770
Erin	Scrip	8263036	High School	Valerie Natale, Maryann Johnson	Approved	05/25/2022 9:08 AM		1.0	No	06/08/2022	No		720552
Beth	Shaffer	1219598	Middle School	Valerie Natale, Maryann Johnson	Approved	05/25/2022 9:08 AM		1.0	No	06/08/2022	No		720551
Erinn	Slacktish	2692105	High School	Valerie Natale, Maryann Johnson	Approved	05/25/2022 9:08 AM		1.0	No	06/08/2022	No		720696
Amber	Staley	2865256	High School	Valerie Natale, Maryann Johnson	Approved	05/25/2022 9:08 AM		1.0	No	06/08/2022	No		720649
Melissa	Stump	8359342	High School	Valerie Natale, Maryann Johnson	Approved	05/25/2022 9:08 AM		1.0	No	06/08/2022	No		720841
John	Thomas	9564086	Middle School	Valerie Natale, Maryann Johnson	Approved	05/25/2022 9:08 AM		1.0	No	06/08/2022	No		720307
Stacy	Vietmeier	5735753	K-8	Valerie Natale, Maryann Johnson	Approved	05/25/2022 9:08 AM		1.0	No	06/08/2022	No		720758
Shari	Widlund	4914824	High School	Valerie Natale, Maryann Johnson	Approved	05/25/2022 9:08 AM		1.0	No	06/08/2022	No		720723
Sasha	Young	6136347	High School	Valerie Natale, Maryann Johnson	Approved	05/25/2022 9:08 AM		1.0	No	06/08/2022	No		720833
Emily	Forrest		K-8	Valerie Natale, Maryann Johnson	Approved	05/25/2022 9:37 AM		1.0	No	06/08/2022	No		958921
Brittany	Brown		K-8	Valerie Natale, Maryann Johnson	Approved	06/07/2022 9:09 AM		1.0	No	06/08/2022	No		958922



# AGENDA

---

Brief Overview of what is a PBSP

Procedure for Case Managers

Review

What's New

Revisions

Reminders

Summary

Q&A



## 1. Summary

Attended participants 137  
Start time "8/24/21, 2:22:06 PM"  
End time "8/24/21, 3:49:54 PM"  
Meeting duration 1h 27m 48s  
Average attendance time 31m 22s

## 2. Participants

Name	First join	Last leave	In-meeting duration	Email	Participant ID (UPN)	Role
Cathryn Mack	"8/24/21, 2:22:59 PM"	"8/24/21, 3:28:17 PM"	1h 5m 18s	cmack@agora.org	cmack@agora.org	Presenter
Kristal Costanzo	"8/24/21, 2:34:07 PM"	"8/24/21, 3:28:30 PM"	34m 54s	kcostanzo@agora.org	kcostanzo@agora.org	Presenter
Maura Basso	"8/24/21, 2:37:13 PM"	"8/24/21, 3:33:32 PM"	55m 7s	mbasso@agora.org	mbasso@agora.org	Presenter
Bridget Ellis	"8/24/21, 2:45:18 PM"	"8/24/21, 3:28:17 PM"	42m 58s	bellis@agora.org	bellis@agora.org	Presenter
Jessica Linderman	"8/24/21, 2:46:29 PM"	"8/24/21, 3:28:34 PM"	42m 4s	jlinderman@agora.org	jlinderman@agora.org	Presenter
Colien Byers	"8/24/21, 2:47:11 PM"	"8/24/21, 3:28:18 PM"	41m 7s	cbyers@agora.org	cbyers@agora.org	Presenter
Joy Fegely	"8/24/21, 2:47:18 PM"	"8/24/21, 3:28:20 PM"	41m 1s	jfegely@agora.org	jfegely@agora.org	Presenter
Barb Cooper	"8/24/21, 2:47:23 PM"	"8/24/21, 3:32:50 PM"	45m 27s	bcooper@agora.org	bcooper@agora.org	Presenter
Amanda Moyer	"8/24/21, 2:47:34 PM"	"8/24/21, 3:28:48 PM"	41m 14s	amoyer@agora.org	amoyer@agora.org	Presenter
Melissa Love	"8/24/21, 2:47:36 PM"	"8/24/21, 3:28:18 PM"	40m 42s	mlove@agora.org	mlove@agora.org	Presenter
Kattreena Amodeo	"8/24/21, 2:47:36 PM"	"8/24/21, 3:28:29 PM"	40m 52s	kamodeo@agora.org	kamodeo@agora.org	Presenter
Terri Hunkele	"8/24/21, 2:47:40 PM"	"8/24/21, 3:28:23 PM"	40m 43s	thunkele@agora.org	thunkele@agora.org	Presenter
Susan Lelko	"8/24/21, 2:47:42 PM"	"8/24/21, 3:28:34 PM"	40m 51s	slelko@agora.org	slelko@agora.org	Presenter
Breanne Scears	"8/24/21, 2:47:43 PM"	"8/24/21, 3:28:09 PM"	40m 25s	bscears@agora.org	bscears@agora.org	Presenter
Lisa Savitz	"8/24/21, 2:47:52 PM"	"8/24/21, 3:28:32 PM"	40m 39s	lsavitz@agora.org	lsavitz@agora.org	Presenter
Shannon Feeney Hoffmaster	"8/24/21, 2:48:00 PM"	"8/24/21, 3:28:29 PM"	40m 29s	shoffmaster@agora.org	shoffmaster@agora.org	Presenter
Amanda Armstrong	"8/24/21, 2:48:10 PM"	"8/24/21, 3:28:24 PM"	40m 14s	aarmstrong@agora.org	aarmstrong@agora.org	Presenter
Heather Silberman	"8/24/21, 2:48:34 PM"	"8/24/21, 3:28:29 PM"	39m 55s	hsilberman@agora.org	hsilberman@agora.org	Presenter
Amy Raught	"8/24/21, 2:49:01 PM"	"8/24/21, 3:28:21 PM"	39m 20s	araught@agora.org	araught@agora.org	Presenter
Tracey Ambuka	"8/24/21, 2:49:43 PM"	"8/24/21, 3:33:24 PM"	43m 40s	tambuka@agora.org	tambuka@agora.org	Presenter
Jesse Capitano	"8/24/21, 2:50:04 PM"	"8/24/21, 3:28:24 PM"	38m 20s	jcapitano@agora.org	jcapitano@agora.org	Presenter
Leslie Spratt	"8/24/21, 2:50:35 PM"	"8/24/21, 3:28:20 PM"	37m 44s	lspratt@agora.org	lspratt@agora.org	Presenter
Carmen Riggle	"8/24/21, 2:50:48 PM"	"8/24/21, 3:28:08 PM"	37m 19s	criggle@agora.org	criggle@agora.org	Presenter
Chris Baker	"8/24/21, 2:51:48 PM"	"8/24/21, 3:28:22 PM"	36m 33s	cbaker@agora.org	cbaker@agora.org	

cbaker@agora.org Presenter  
 Allison Large "8/24/21, 2:51:59 PM" "8/24/21, 3:28:23 PM" 36m 23s alarge@agora.org  
 alarge@agora.org Presenter  
 Nancy Reimers "8/24/21, 2:52:22 PM" "8/24/21, 3:28:25 PM" 36m 3s nreimers@agora.org  
 nreimers@agora.org Presenter  
 Marlee Atwood "8/24/21, 2:52:22 PM" "8/24/21, 3:28:21 PM" 35m 58s matwood@agora.org  
 matwood@agora.org Presenter  
 Jessica Barnhart "8/24/21, 2:52:37 PM" "8/24/21, 3:28:19 PM" 35m 41s jbarnhart@agora.org  
 jbarnhart@agora.org Presenter  
 Tamara Kozak "8/24/21, 2:52:43 PM" "8/24/21, 3:28:51 PM" 36m 8s tkozak@agora.org  
 tkozak@agora.org Presenter  
 Theresa Bash "8/24/21, 2:53:00 PM" "8/24/21, 3:28:18 PM" 35m 18s tbash@agora.org  
 tbash@agora.org Presenter  
 Jennifer Cadieux "8/24/21, 2:53:03 PM" "8/24/21, 3:28:31 PM" 35m 27s jcadieux@agora.org  
 jcadieux@agora.org Presenter  
 Brittany Froehlich "8/24/21, 2:53:22 PM" "8/24/21, 3:28:48 PM" 35m 26s BFroehlich@agora.org  
 BFroehlich@agora.org Presenter  
 Jennifer Flatley "8/24/21, 2:54:00 PM" "8/24/21, 3:32:14 PM" 38m 13s jflatley@agora.org  
 jflatley@agora.org Presenter  
 Molly Garczynski "8/24/21, 2:54:18 PM" "8/24/21, 3:28:24 PM" 34m 5s mgarczynski@agora.org  
 mgarczynski@agora.org Presenter  
 Cathrine Hartman "8/24/21, 2:54:39 PM" "8/24/21, 3:28:17 PM" 33m 38s chartman@agora.org  
 chartman@agora.org Presenter  
 Janet Ulewicz "8/24/21, 2:54:44 PM" "8/24/21, 3:28:21 PM" 33m 37s julewicz@agora.org  
 julewicz@agora.org Presenter  
 Michelle Pelissier "8/24/21, 2:54:47 PM" "8/24/21, 3:28:18 PM" 33m 31s mpelissier@agora.org  
 mpelissier@agora.org Presenter  
 Jodeen Buckwalter "8/24/21, 2:54:48 PM" "8/24/21, 3:28:19 PM" 33m 30s jbuckwalter@agora.org  
 jbuckwalter@agora.org Presenter  
 Susan Lipiec "8/24/21, 2:54:53 PM" "8/24/21, 3:28:40 PM" 33m 46s slipiec@agora.org  
 slipiec@agora.org Presenter  
 Melissa McCracken "8/24/21, 2:54:55 PM" "8/24/21, 3:28:27 PM" 33m 31s mmccracken@agora.org  
 mmccracken@agora.org Presenter  
 Maryann Johnson "8/24/21, 2:55:02 PM" "8/24/21, 3:32:40 PM" 37m 38s majohnson@agora.org  
 majohnson@agora.org Organizer  
 Theresa Draeger "8/24/21, 2:55:09 PM" "8/24/21, 3:49:54 PM" 54m 44s tdraeger@agora.org  
 tdraeger@agora.org Presenter  
 Melanie Stanforth "8/24/21, 2:55:12 PM" "8/24/21, 3:28:21 PM" 33m 8s mstanforth@agora.org  
 mstanforth@agora.org Presenter  
 Regina Kubica "8/24/21, 2:55:18 PM" "8/24/21, 3:28:01 PM" 32m 42s rkubica@agora.org  
 rkubica@agora.org Presenter  
 Kristina Lapsker "8/24/21, 2:55:23 PM" "8/24/21, 3:28:22 PM" 32m 58s klapsker@agora.org  
 klapsker@agora.org Presenter  
 Nicole Krol "8/24/21, 2:55:25 PM" "8/24/21, 3:24:33 PM" 29m 8s nkrol@agora.org nkrol@agora.org  
 Presenter  
 Jen Lucia "8/24/21, 2:55:37 PM" "8/24/21, 3:32:35 PM" 36m 57s jlucia@agora.org  
 jlucia@agora.org Presenter  
 Crystal Long "8/24/21, 2:55:41 PM" "8/24/21, 3:28:18 PM" 32m 36s clong@agora.org clong@agora.org  
 Presenter  
 Sabrina Kennedy "8/24/21, 2:55:46 PM" "8/24/21, 3:28:16 PM" 32m 30s skennedy@agora.org  
 skennedy@agora.org Presenter  
 Lisa Brestensky "8/24/21, 2:55:54 PM" "8/24/21, 3:28:44 PM" 32m 49s lbrestensky@agora.org  
 lbrestensky@agora.org Presenter  
 Brianna Pontious "8/24/21, 2:55:55 PM" "8/24/21, 3:28:25 PM" 32m 30s bpontious@agora.org  
 bpontious@agora.org Presenter  
 Brittany Reamer "8/24/21, 2:55:59 PM" "8/24/21, 3:28:15 PM" 32m 16s breamer@agora.org  
 breamer@agora.org Presenter

Michelle Olsavsky "8/24/21, 2:56:00 PM" "8/24/21, 3:28:22 PM" 32m 22s molsavsky@agora.org  
molsavsky@agora.org Presenter  
Casey Chaffin "8/24/21, 2:56:08 PM" "8/24/21, 3:28:27 PM" 32m 18s cchaffin@agora.org  
cchaffin@agora.org Presenter  
Jill Moyer "8/24/21, 2:56:09 PM" "8/24/21, 3:28:22 PM" 32m 13s jmoyer2@agora.org  
jmoyer2@agora.org Presenter  
Lauren Kerns "8/24/21, 2:56:09 PM" "8/24/21, 3:28:28 PM" 32m 18s lkerns@agora.org  
lkerns@agora.org Presenter  
Jennifer Buss "8/24/21, 2:56:19 PM" "8/24/21, 3:28:27 PM" 32m 7s jbus@agora.org jbus@agora.org  
Presenter  
Katie O'Donnell "8/24/21, 2:56:21 PM" "8/24/21, 3:28:19 PM" 31m 57s kodonnell@agora.org  
kodonnell@agora.org Presenter  
"Anne Butler, Ed.D" "8/24/21, 2:56:35 PM" "8/24/21, 3:05:10 PM" 8m 35s abutler@agora.org  
abutler@agora.org Presenter  
Serena Adams "8/24/21, 2:56:36 PM" "8/24/21, 3:28:13 PM" 31m 37s sadams@agora.org  
sadams@agora.org Presenter  
Samantha Bonniger "8/24/21, 2:56:44 PM" "8/24/21, 3:28:24 PM" 31m 40s sbonniger@agora.org  
sbonniger@agora.org Presenter  
Jill Severino "8/24/21, 2:56:49 PM" "8/24/21, 3:28:42 PM" 31m 53s jseverino@agora.org  
jseverino@agora.org Presenter  
Jennifer Zollman "8/24/21, 2:56:51 PM" "8/24/21, 3:28:20 PM" 31m 28s jzollman@agora.org  
jzollman@agora.org Presenter  
Brittney Walczak "8/24/21, 2:56:54 PM" "8/24/21, 3:28:07 PM" 31m 12s bwalczak@agora.org  
bwalczak@agora.org Presenter  
Ashley Farster "8/24/21, 2:56:57 PM" "8/24/21, 3:28:25 PM" 31m 27s afarster@agora.org  
afarster@agora.org Presenter  
Laura Stapf "8/24/21, 2:57:01 PM" "8/24/21, 3:28:19 PM" 31m 18s lstapf@agora.org  
lstapf@agora.org Presenter  
Shari Widlund "8/24/21, 2:57:07 PM" "8/24/21, 3:28:23 PM" 31m 15s swidlund@agora.org  
swidlund@agora.org Presenter  
Kelly Berstecher "8/24/21, 2:57:08 PM" "8/24/21, 3:28:19 PM" 31m 11s kberstecher@agora.org  
kberstecher@agora.org Presenter  
Jena Huffman "8/24/21, 2:57:12 PM" "8/24/21, 3:32:22 PM" 35m 9s jhuffman@agora.org  
jhuffman@agora.org Presenter  
Jenna Lee Dietrich "8/24/21, 2:57:19 PM" "8/24/21, 3:28:26 PM" 31m 7s jdietrich@agora.org  
jdietrich@agora.org Presenter  
Dana O'Donnell "8/24/21, 2:57:31 PM" "8/24/21, 3:28:30 PM" 30m 58s Dodonnell@agora.org  
Dodonnell@agora.org Presenter  
Lauren Svonavec "8/24/21, 2:57:34 PM" "8/24/21, 3:28:18 PM" 30m 44s lsvonavec@agora.org  
lsvonavec@agora.org Presenter  
Judy Deemer "8/24/21, 2:57:38 PM" "8/24/21, 3:28:21 PM" 30m 42s jdeemer@agora.org  
jdeemer@agora.org Presenter  
Rachel Carmichael "8/24/21, 2:57:41 PM" "8/24/21, 3:28:25 PM" 30m 43s rcarmichael@agora.org  
rcarmichael@agora.org Presenter  
Melissa Gaso "8/24/21, 2:57:48 PM" "8/24/21, 3:28:35 PM" 30m 47s mgaso@agora.org  
mgaso@agora.org Presenter  
Maria Harlan "8/24/21, 2:57:57 PM" "8/24/21, 3:28:19 PM" 30m 22s mharlan@agora.org  
mharlan@agora.org Presenter  
Gillian Kaufman "8/24/21, 2:57:58 PM" "8/24/21, 3:28:30 PM" 30m 32s gkaufman@agora.org  
gkaufman@agora.org Presenter  
David Furka "8/24/21, 2:58:00 PM" "8/24/21, 3:28:28 PM" 30m 27s dfurka@agora.org  
dfurka@agora.org Presenter  
Regina Mallon "8/24/21, 2:58:04 PM" "8/24/21, 3:28:22 PM" 30m 18s gmallon@agora.org  
gmallon@agora.org Presenter  
Jennifer McGinty "8/24/21, 2:58:06 PM" "8/24/21, 3:28:24 PM" 30m 17s jmcginty@agora.org  
jmcginty@agora.org Presenter  
Jennifer Beeken "8/24/21, 2:58:07 PM" "8/24/21, 3:28:33 PM" 30m 26s jbeeken@agora.org

jbeeken@agora.org Presenter  
 Carissa Emrick "8/24/21, 2:58:16 PM""8/24/21, 3:28:26 PM"30m 10s cemrick@agora.org  
 cemrick@agora.org Presenter  
 Amanda Kammermeier "8/24/21, 2:58:27 PM""8/24/21, 3:28:18 PM"29m 50s  
 akammermeier@agora.org akammermeier@agora.org Presenter  
 Amber Staley "8/24/21, 2:58:27 PM""8/24/21, 3:28:19 PM"29m 51s astaley2@agora.org  
 astaley2@agora.org Presenter  
 Tara Walker "8/24/21, 2:58:32 PM""8/24/21, 3:28:14 PM"29m 41s twalker@agora.org  
 twalker@agora.org Presenter  
 Rachel Weeks "8/24/21, 2:59:02 PM""8/24/21, 3:28:20 PM"29m 18s rweeks@agora.org  
 rweeks@agora.org Presenter  
 Veronica Jackson "8/24/21, 2:59:11 PM""8/24/21, 3:28:32 PM"29m 20s vjackson@agora.org  
 vjackson@agora.org Presenter  
 Lauren Lamison "8/24/21, 2:59:11 PM""8/24/21, 3:28:17 PM"29m 5s llamison@agora.org  
 llamison@agora.org Presenter  
 Kimberly Paolino "8/24/21, 2:59:14 PM""8/24/21, 3:28:18 PM"29m 3s kpaolino@agora.org  
 kpaolino@agora.org Presenter  
 Cathryn Ramsey "8/24/21, 2:59:35 PM""8/24/21, 3:28:28 PM"28m 52s cramsey@agora.org  
 cramsey@agora.org Presenter  
 Brittney Cantwell "8/24/21, 2:59:36 PM""8/24/21, 3:28:30 PM"28m 54s bcantwell@agora.org  
 bcantwell@agora.org Presenter  
 Christen Widdop "8/24/21, 2:59:37 PM""8/24/21, 3:28:21 PM"28m 44s cwiddop@agora.org  
 cwiddop@agora.org Presenter  
 Anna Lepsch "8/24/21, 2:59:43 PM""8/24/21, 3:28:32 PM"28m 49s alepsch@agora.org  
 alepsch@agora.org Presenter  
 Melissa Hale-Patterson "8/24/21, 2:59:43 PM""8/24/21, 3:28:50 PM"29m 7s mpatterson@agora.org  
 mpatterson@agora.org Presenter  
 Rebekah Congdon "8/24/21, 2:59:43 PM""8/24/21, 3:28:16 PM"28m 33s rcongdon@agora.org  
 rcongdon@agora.org Presenter  
 Sarah Pittman "8/24/21, 2:59:44 PM""8/24/21, 3:28:56 PM"16m 34s spittman@agora.org  
 spittman@agora.org Presenter  
 Anna Baranoski "8/24/21, 2:59:51 PM""8/24/21, 3:28:20 PM"28m 28s abaranoski@agora.org  
 abaranoski@agora.org Presenter  
 Shelley Stump "8/24/21, 2:59:55 PM""8/24/21, 3:32:08 PM"32m 12s sstump@agora.org  
 sstump@agora.org Presenter  
 Stacy Vietmeier "8/24/21, 2:59:59 PM""8/24/21, 3:28:29 PM"28m 29s svietmeier@agora.org  
 svietmeier@agora.org Presenter  
 Melissa Stump "8/24/21, 3:00:01 PM""8/24/21, 3:28:17 PM"28m 16s mstump@agora.org  
 mstump@agora.org Presenter  
 Amber Brisbane "8/24/21, 3:00:01 PM""8/24/21, 3:28:18 PM"28m 16s abrisbane@agora.org  
 abrisbane@agora.org Presenter  
 Angela Denham "8/24/21, 3:00:02 PM""8/24/21, 3:28:19 PM"28m 16s adenham@agora.org  
 adenham@agora.org Presenter  
 Gemma Mattox "8/24/21, 3:00:04 PM""8/24/21, 3:28:25 PM"28m 20s gmattox@agora.org  
 gmattox@agora.org Presenter  
 John Thomas "8/24/21, 3:00:08 PM""8/24/21, 3:28:11 PM"28m 2s jthomas@agora.org  
 jthomas@agora.org Presenter  
 Jennifer DePietro "8/24/21, 3:00:09 PM""8/24/21, 3:28:27 PM"28m 18s jdepietro@agora.org  
 jdepietro@agora.org Presenter  
 Danielle Pricer "8/24/21, 3:00:18 PM""8/24/21, 3:28:38 PM"28m 20s dpricer@agora.org  
 dpricer@agora.org Presenter  
 Stefanie Marcello "8/24/21, 3:00:32 PM""8/24/21, 3:29:28 PM"28m 56s smarcello@agora.org  
 smarcello@agora.org Presenter  
 Cortney Barkley "8/24/21, 3:00:34 PM""8/24/21, 3:28:18 PM"27m 44s cbarkley@agora.org  
 cbarkley@agora.org Presenter  
 Brett Stevens "8/24/21, 3:00:34 PM""8/24/21, 3:28:17 PM"27m 43s bstevens2@agora.org  
 bstevens2@agora.org Presenter

Melissa Franklin "8/24/21, 3:00:42 PM""8/24/21, 3:29:28 PM"28m 46s mfranklin@agora.org  
mfranklin@agora.org Presenter  
Kristy Welsh "8/24/21, 3:00:51 PM""8/24/21, 3:25:13 PM"24m 22s kwelsh@agora.org  
kwelsh@agora.org Presenter  
Lynn Pagliei "8/24/21, 3:00:54 PM""8/24/21, 3:28:14 PM"27m 20s lpagliei@agora.org  
lpagliei@agora.org Presenter  
Renee Perri "8/24/21, 3:00:58 PM""8/24/21, 3:28:16 PM"27m 17s rperri@agora.org  
rperri@agora.org Presenter  
Gina Rodriguez "8/24/21, 3:01:04 PM""8/24/21, 3:28:22 PM"27m 17s grodriguez@agora.org  
grodriguez@agora.org Presenter  
Dana Pacolay "8/24/21, 3:01:23 PM""8/24/21, 3:28:48 PM"27m 25s dpacolay@agora.org  
dpacolay@agora.org Presenter  
Chelsey Panchura "8/24/21, 3:01:29 PM""8/24/21, 3:28:42 PM"27m 13s cpanchura@agora.org  
cpanchura@agora.org Presenter  
Kymberly Humanick "8/24/21, 3:01:31 PM""8/24/21, 3:28:23 PM"26m 51s khumanick@agora.org  
khumanick@agora.org Presenter  
Valerie Natale "8/24/21, 3:01:41 PM""8/24/21, 3:29:17 PM"27m 36s vnatale@agora.org  
vnatale@agora.org Presenter  
Patrick Lavelle "8/24/21, 3:01:48 PM""8/24/21, 3:28:20 PM"26m 32s plavelle@agora.org  
plavelle@agora.org Presenter  
Janelle Shaffer "8/24/21, 3:01:48 PM""8/24/21, 3:28:20 PM"26m 32s jshaffer3@agora.org  
jshaffer3@agora.org Presenter  
Kaelyn Hoffman "8/24/21, 3:01:55 PM""8/24/21, 3:28:44 PM"26m 48s khoffman@agora.org  
khoffman@agora.org Presenter  
Heidi Dodge "8/24/21, 3:02:23 PM""8/24/21, 3:28:31 PM"26m 8s hdodge@agora.org  
hdodge@agora.org Presenter  
Erin Scrip "8/24/21, 3:02:24 PM""8/24/21, 3:34:19 PM"28m 42s escrip@agora.org escrip@agora.org  
Presenter  
Julie Doebereiner "8/24/21, 3:03:14 PM""8/24/21, 3:35:44 PM"32m 29s jdoebereiner@agora.org  
jdoebereiner@agora.org Presenter  
Olivia Eckels "8/24/21, 3:04:33 PM""8/24/21, 3:28:25 PM"23m 51s oeckels@agora.org  
oeckels@agora.org Presenter  
Danielle Schall "8/24/21, 3:04:57 PM""8/24/21, 3:28:26 PM"23m 28s dschall@agora.org  
dschall@agora.org Presenter  
Sasha Young "8/24/21, 3:05:09 PM""8/24/21, 3:28:21 PM"23m 11s syoung@agora.org  
syoung@agora.org Presenter  
Lauren Radico "8/24/21, 3:05:25 PM""8/24/21, 3:29:20 PM"23m 54s lradico@agora.org  
lradico@agora.org Presenter  
Heather Gallagher "8/24/21, 3:05:43 PM""8/24/21, 3:30:28 PM"24m 45s hgallagher@agora.org  
hgallagher@agora.org Presenter  
Erin Connor "8/24/21, 3:06:23 PM""8/24/21, 3:11:02 PM"4m 39s econnor@agora.org  
econnor@agora.org Presenter  
Whitney Bargerstock "8/24/21, 3:07:41 PM""8/24/21, 3:30:56 PM"23m 14s wbargerstock@agora.org  
wbargerstock@agora.org Presenter  
Kimberly Fiscus "8/24/21, 3:07:46 PM""8/24/21, 3:28:19 PM"20m 32s kfiscus@agora.org  
kfiscus@agora.org Presenter  
Colleen Freyvogel Bruss "8/24/21, 3:08:58 PM""8/24/21, 3:28:22 PM"19m 23s cfreyvogel@agora.org  
cfreyvogel@agora.org Presenter  
Mindy Wesley "8/24/21, 3:13:21 PM""8/24/21, 3:14:30 PM"1m 9s mwesley@agora.org  
mwesley@agora.org Presenter  
Christine Thomas "8/24/21, 3:15:15 PM""8/24/21, 3:28:24 PM"13m 8s cthomas@agora.org  
cthomas@agora.org Presenter  
Erinn Slacktish "8/24/21, 3:15:21 PM""8/24/21, 3:28:21 PM"13m eslacktish@agora.org  
eslacktish@agora.org Presenter  
Kimberly McLaughlin "8/24/21, 3:26:26 PM""8/24/21, 3:28:31 PM"2m 5s kmclaughlin@agora.org  
kmclaughlin@agora.org Presenter

### 3. In-Meeting activities

Name	Join time	Leave time	Duration	Email	Role
Cathryn Mack	"8/24/21, 2:22:59 PM"	"8/24/21, 3:28:17 PM"	1h 5m 18s	cmack@agora.org	Presenter
Kristal Costanzo	"8/24/21, 2:34:07 PM"	"8/24/21, 2:34:34 PM"	26s	kcostanzo@agora.org	Presenter
Kristal Costanzo	"8/24/21, 2:54:01 PM"	"8/24/21, 3:28:30 PM"	34m 28s	kcostanzo@agora.org	Presenter
Maura Basso	"8/24/21, 2:37:13 PM"	"8/24/21, 3:31:17 PM"	54m 4s	mbasso@agora.org	Presenter
Maura Basso	"8/24/21, 3:32:28 PM"	"8/24/21, 3:33:32 PM"	1m 3s	mbasso@agora.org	Presenter
Bridget Ellis	"8/24/21, 2:45:18 PM"	"8/24/21, 3:28:17 PM"	42m 58s	bellis@agora.org	Presenter
Jessica Linderman	"8/24/21, 2:46:29 PM"	"8/24/21, 3:28:34 PM"	42m 4s	jlinderman@agora.org	Presenter
Colien Byers	"8/24/21, 2:47:11 PM"	"8/24/21, 3:28:18 PM"	41m 7s	cbyers@agora.org	Presenter
Joy Fegely	"8/24/21, 2:47:18 PM"	"8/24/21, 3:28:20 PM"	41m 1s	jfegely@agora.org	Presenter
Barb Cooper	"8/24/21, 2:47:23 PM"	"8/24/21, 3:32:50 PM"	45m 27s	bcooper@agora.org	Presenter
Amanda Moyer	"8/24/21, 2:47:34 PM"	"8/24/21, 3:28:48 PM"	41m 14s	amoyer@agora.org	Presenter
Melissa Love	"8/24/21, 2:47:36 PM"	"8/24/21, 3:28:18 PM"	40m 42s	mlove@agora.org	Presenter
Kattreena Amodeo	"8/24/21, 2:47:36 PM"	"8/24/21, 3:28:29 PM"	40m 52s	kamodeo@agora.org	Presenter
Terri Hunkele	"8/24/21, 2:47:40 PM"	"8/24/21, 3:28:23 PM"	40m 43s	thunkele@agora.org	Presenter
Susan Lelko	"8/24/21, 2:47:42 PM"	"8/24/21, 3:28:34 PM"	40m 51s	slelko@agora.org	Presenter
Breanne Scears	"8/24/21, 2:47:43 PM"	"8/24/21, 3:28:09 PM"	40m 25s	bscears@agora.org	Presenter
Lisa Savitz	"8/24/21, 2:47:52 PM"	"8/24/21, 3:28:32 PM"	40m 39s	lsavitz@agora.org	Presenter
Shannon Feeney Hoffmaster	"8/24/21, 2:48:00 PM"	"8/24/21, 3:28:29 PM"	40m 29s	shoffmaster@agora.org	Presenter
Amanda Armstrong	"8/24/21, 2:48:10 PM"	"8/24/21, 3:28:24 PM"	40m 14s	aarmstrong@agora.org	Presenter
Heather Silberman	"8/24/21, 2:48:34 PM"	"8/24/21, 3:28:29 PM"	39m 55s	hsilberman@agora.org	Presenter
Amy Raught	"8/24/21, 2:49:01 PM"	"8/24/21, 3:28:21 PM"	39m 20s	araught@agora.org	Presenter
Tracey Ambuka	"8/24/21, 2:49:43 PM"	"8/24/21, 3:33:24 PM"	43m 40s	tambuka@agora.org	Presenter
Jesse Capitano	"8/24/21, 2:50:04 PM"	"8/24/21, 3:28:24 PM"	38m 20s	jcapitano@agora.org	Presenter
Leslie Spratt	"8/24/21, 2:50:35 PM"	"8/24/21, 3:28:20 PM"	37m 44s	lspratt@agora.org	Presenter
Carmen Riggle	"8/24/21, 2:50:48 PM"	"8/24/21, 3:28:08 PM"	37m 19s	criggle@agora.org	Presenter
Chris Baker	"8/24/21, 2:51:48 PM"	"8/24/21, 3:28:22 PM"	36m 33s	cbaker@agora.org	Presenter
Allison Large	"8/24/21, 2:51:59 PM"	"8/24/21, 3:28:23 PM"	36m 23s	alarge@agora.org	Presenter
Nancy Reimers	"8/24/21, 2:52:22 PM"	"8/24/21, 3:28:25 PM"	36m 3s	nreimers@agora.org	Presenter
Marlee Atwood	"8/24/21, 2:52:22 PM"	"8/24/21, 3:28:21 PM"	35m 58s	matwood@agora.org	Presenter
Jessica Barnhart	"8/24/21, 2:52:37 PM"	"8/24/21, 3:28:19 PM"	35m 41s	jbarnhart@agora.org	Presenter
Tamara Kozak	"8/24/21, 2:52:43 PM"	"8/24/21, 3:28:51 PM"	36m 8s	tkozak@agora.org	Presenter
Theresa Bash	"8/24/21, 2:53:00 PM"	"8/24/21, 3:28:18 PM"	35m 18s	tbash@agora.org	Presenter
Jennifer Cadieux	"8/24/21, 2:53:03 PM"	"8/24/21, 3:28:31 PM"	35m 27s	jcadieux@agora.org	Presenter
Brittany Froehlich	"8/24/21, 2:53:22 PM"	"8/24/21, 3:28:48 PM"	35m 26s	BFroehlich@agora.org	Presenter
Jennifer Flatley	"8/24/21, 2:54:00 PM"	"8/24/21, 3:32:14 PM"	38m 13s	jflatley@agora.org	Presenter
Molly Garczynski	"8/24/21, 2:54:18 PM"	"8/24/21, 3:28:24 PM"	34m 5s	mgarczynski@agora.org	Presenter
Cathrine Hartman	"8/24/21, 2:54:39 PM"	"8/24/21, 3:28:17 PM"	33m 38s	chartman@agora.org	Presenter
Janet Ulewicz	"8/24/21, 2:54:44 PM"	"8/24/21, 3:28:21 PM"	33m 37s	julewicz@agora.org	Presenter
Michelle Pelissier	"8/24/21, 2:54:47 PM"	"8/24/21, 3:28:18 PM"	33m 31s	mpelissier@agora.org	Presenter
Jodeen Buckwalter	"8/24/21, 2:54:48 PM"	"8/24/21, 3:28:19 PM"	33m 30s	jbuckwalter@agora.org	Presenter
Susan Lipiec	"8/24/21, 2:54:53 PM"	"8/24/21, 3:28:40 PM"	33m 46s	slipiec@agora.org	Presenter
Melissa McCracken	"8/24/21, 2:54:55 PM"	"8/24/21, 3:28:27 PM"	33m 31s	mmccracken@agora.org	Presenter
Maryann Johnson	"8/24/21, 2:55:02 PM"	"8/24/21, 3:32:40 PM"	37m 38s	majohnson@agora.org	Organizer
Theresa Draeger	"8/24/21, 2:55:09 PM"	"8/24/21, 3:49:54 PM"	54m 44s	tdraeger@agora.org	Presenter

Melanie Stanforth "8/24/21, 2:55:12 PM""8/24/21, 3:28:21 PM"33m 8s mstanforth@agora.org  
Presenter  
Regina Kubica "8/24/21, 2:55:18 PM""8/24/21, 3:28:01 PM"32m 42s rkubica@agora.org Presenter  
Kristina Lapsker "8/24/21, 2:55:23 PM""8/24/21, 3:28:22 PM"32m 58s klapsker@agora.org Presenter  
Nicole Krol "8/24/21, 2:55:25 PM""8/24/21, 3:24:33 PM"29m 8s nkrol@agora.org Presenter  
Jen Lucia "8/24/21, 2:55:37 PM""8/24/21, 3:32:35 PM"36m 57s jlucia@agora.org Presenter  
Crystal Long "8/24/21, 2:55:41 PM""8/24/21, 3:28:18 PM"32m 36s clong@agora.org Presenter  
Sabrina Kennedy "8/24/21, 2:55:46 PM""8/24/21, 3:28:16 PM"32m 30s skennedy@agora.org Presenter  
Lisa Brestensky "8/24/21, 2:55:54 PM""8/24/21, 3:28:44 PM"32m 49s lbrestensky@agora.org  
Presenter  
Brianna Pontious "8/24/21, 2:55:55 PM""8/24/21, 3:28:25 PM"32m 30s bpontious@agora.org Presenter  
Brittany Reamer "8/24/21, 2:55:59 PM""8/24/21, 3:28:15 PM"32m 16s breamer@agora.org Presenter  
Michelle Olsavsky "8/24/21, 2:56:00 PM""8/24/21, 3:28:22 PM"32m 22s molsavsky@agora.org  
Presenter  
Casey Chaffin "8/24/21, 2:56:08 PM""8/24/21, 3:28:27 PM"32m 18s cchaffin@agora.org Presenter  
Jill Moyer "8/24/21, 2:56:09 PM""8/24/21, 3:28:22 PM"32m 13s jmoyer2@agora.org Presenter  
Lauren Kerns "8/24/21, 2:56:09 PM""8/24/21, 3:28:28 PM"32m 18s lkerns@agora.org Presenter  
Jennifer Buss "8/24/21, 2:56:19 PM""8/24/21, 3:28:27 PM"32m 7s jbus@agora.org Presenter  
Katie O'Donnell "8/24/21, 2:56:21 PM""8/24/21, 3:28:19 PM"31m 57s kodonnell@agora.org Presenter  
"Anne Butler, Ed.D" "8/24/21, 2:56:35 PM""8/24/21, 3:05:10 PM"8m 35s abutler@agora.org  
Presenter  
Serena Adams "8/24/21, 2:56:36 PM""8/24/21, 3:28:13 PM"31m 37s sadams@agora.org Presenter  
Samantha Bonniger "8/24/21, 2:56:44 PM""8/24/21, 3:28:24 PM"31m 40s sbonniger@agora.org  
Presenter  
Jill Severino "8/24/21, 2:56:49 PM""8/24/21, 3:28:42 PM"31m 53s jseverino@agora.org Presenter  
Jennifer Zollman "8/24/21, 2:56:51 PM""8/24/21, 3:28:20 PM"31m 28s jzollman@agora.org Presenter  
Brittney Walczak "8/24/21, 2:56:54 PM""8/24/21, 3:28:07 PM"31m 12s bwalczak@agora.org Presenter  
Ashley Farster "8/24/21, 2:56:57 PM""8/24/21, 3:28:25 PM"31m 27s afarster@agora.org Presenter  
Laura Stapf "8/24/21, 2:57:01 PM""8/24/21, 3:28:19 PM"31m 18s lstapf@agora.org Presenter  
Shari Widlund "8/24/21, 2:57:07 PM""8/24/21, 3:28:23 PM"31m 15s swidlund@agora.org Presenter  
Kelly Berstecher "8/24/21, 2:57:08 PM""8/24/21, 3:28:19 PM"31m 11s kberstecher@agora.org  
Presenter  
Jena Huffman "8/24/21, 2:57:12 PM""8/24/21, 3:32:22 PM"35m 9s jhuffman@agora.org Presenter  
Jenna Lee Dietrich "8/24/21, 2:57:19 PM""8/24/21, 3:28:26 PM"31m 7s jdietrich@agora.org  
Presenter  
Dana O'Donnell "8/24/21, 2:57:31 PM""8/24/21, 3:28:30 PM"30m 58s Dodonnell@agora.org Presenter  
Lauren Svonavec "8/24/21, 2:57:34 PM""8/24/21, 3:28:18 PM"30m 44s lsvonavec@agora.org  
Presenter  
Judy Deemer "8/24/21, 2:57:38 PM""8/24/21, 3:28:21 PM"30m 42s jdeemer@agora.org Presenter  
Rachel Carmichael "8/24/21, 2:57:41 PM""8/24/21, 3:28:25 PM"30m 43s rcarmichael@agora.org  
Presenter  
Melissa Gaso "8/24/21, 2:57:48 PM""8/24/21, 3:28:35 PM"30m 47s mgaso@agora.org Presenter  
Maria Harlan "8/24/21, 2:57:57 PM""8/24/21, 3:28:19 PM"30m 22s mharlan@agora.org Presenter  
Gillian Kaufman "8/24/21, 2:57:58 PM""8/24/21, 3:28:30 PM"30m 32s gkaufman@agora.org Presenter  
David Furka "8/24/21, 2:58:00 PM""8/24/21, 3:28:28 PM"30m 27s dfurka@agora.org Presenter  
Regina Mallon "8/24/21, 2:58:04 PM""8/24/21, 3:28:22 PM"30m 18s gmallon@agora.org Presenter  
Jennifer McGinty "8/24/21, 2:58:06 PM""8/24/21, 3:28:24 PM"30m 17s jmcginty@agora.org Presenter  
Jennifer Beeken "8/24/21, 2:58:07 PM""8/24/21, 3:28:33 PM"30m 26s jbeeken@agora.org Presenter  
Carissa Emrick "8/24/21, 2:58:16 PM""8/24/21, 3:28:26 PM"30m 10s cemrick@agora.org Presenter  
Amanda Kammermeier "8/24/21, 2:58:27 PM""8/24/21, 3:28:18 PM"29m 50s  
akammermeier@agora.org Presenter  
Amber Staley "8/24/21, 2:58:27 PM""8/24/21, 3:28:19 PM"29m 51s astaley2@agora.org Presenter  
Tara Walker "8/24/21, 2:58:32 PM""8/24/21, 3:28:14 PM"29m 41s twalker@agora.org Presenter  
Rachel Weeks "8/24/21, 2:59:02 PM""8/24/21, 3:28:20 PM"29m 18s rweeks@agora.org Presenter  
Veronica Jackson "8/24/21, 2:59:11 PM""8/24/21, 3:28:32 PM"29m 20s vjackson@agora.org  
Presenter  
Lauren Lamison "8/24/21, 2:59:11 PM""8/24/21, 3:28:17 PM"29m 5s llamison@agora.org Presenter



Kimberly Paolino	"8/24/21, 2:59:14 PM"	"8/24/21, 3:28:18 PM"	29m 3s	kpaolino@agora.org	Presenter
Cathryn Ramsey	"8/24/21, 2:59:35 PM"	"8/24/21, 3:28:28 PM"	28m 52s	cramsey@agora.org	Presenter
Brittney Cantwell	"8/24/21, 2:59:36 PM"	"8/24/21, 3:28:30 PM"	28m 54s	bcantwell@agora.org	Presenter
Christen Widdop	"8/24/21, 2:59:37 PM"	"8/24/21, 3:28:21 PM"	28m 44s	cwiddop@agora.org	Presenter
Anna Lepsch	"8/24/21, 2:59:43 PM"	"8/24/21, 3:28:32 PM"	28m 49s	alepsch@agora.org	Presenter
Melissa Hale-Patterson	"8/24/21, 2:59:43 PM"	"8/24/21, 3:28:50 PM"	29m 7s	mpatterson@agora.org	Presenter
Rebekah Congdon	"8/24/21, 2:59:43 PM"	"8/24/21, 3:28:16 PM"	28m 33s	rcongdon@agora.org	Presenter
Sarah Pittman	"8/24/21, 2:59:44 PM"	"8/24/21, 3:15:59 PM"	16m 15s	spittman@agora.org	Presenter
Sarah Pittman	"8/24/21, 3:28:37 PM"	"8/24/21, 3:28:56 PM"	19s	spittman@agora.org	Presenter
Anna Baranoski	"8/24/21, 2:59:51 PM"	"8/24/21, 3:28:20 PM"	28m 28s	abaranoski@agora.org	Presenter
Shelley Stump	"8/24/21, 2:59:55 PM"	"8/24/21, 3:32:08 PM"	32m 12s	sstump@agora.org	Presenter
Stacy Vietmeier	"8/24/21, 2:59:59 PM"	"8/24/21, 3:28:29 PM"	28m 29s	svietmeier@agora.org	Presenter
Melissa Stump	"8/24/21, 3:00:01 PM"	"8/24/21, 3:28:17 PM"	28m 16s	mstump@agora.org	Presenter
Amber Brisbane	"8/24/21, 3:00:01 PM"	"8/24/21, 3:28:18 PM"	28m 16s	abrisbane@agora.org	Presenter
Angela Denham	"8/24/21, 3:00:02 PM"	"8/24/21, 3:28:19 PM"	28m 16s	adenham@agora.org	Presenter
Gemma Mattox	"8/24/21, 3:00:04 PM"	"8/24/21, 3:28:25 PM"	28m 20s	gmattox@agora.org	Presenter
John Thomas	"8/24/21, 3:00:08 PM"	"8/24/21, 3:28:11 PM"	28m 2s	jthomas@agora.org	Presenter
Jennifer DePietro	"8/24/21, 3:00:09 PM"	"8/24/21, 3:28:27 PM"	28m 18s	jdepietro@agora.org	Presenter
Danielle Pricer	"8/24/21, 3:00:18 PM"	"8/24/21, 3:28:38 PM"	28m 20s	dpricer@agora.org	Presenter
Stefanie Marcello	"8/24/21, 3:00:32 PM"	"8/24/21, 3:29:28 PM"	28m 56s	smarcello@agora.org	Presenter
Cortney Barkley	"8/24/21, 3:00:34 PM"	"8/24/21, 3:28:18 PM"	27m 44s	cbarkley@agora.org	Presenter
Brett Stevens	"8/24/21, 3:00:34 PM"	"8/24/21, 3:28:17 PM"	27m 43s	bstevens2@agora.org	Presenter
Melissa Franklin	"8/24/21, 3:00:42 PM"	"8/24/21, 3:29:28 PM"	28m 46s	mfranklin@agora.org	Presenter
Kristy Welsh	"8/24/21, 3:00:51 PM"	"8/24/21, 3:25:13 PM"	24m 22s	kwelsh@agora.org	Presenter
Lynn Pagliei	"8/24/21, 3:00:54 PM"	"8/24/21, 3:28:14 PM"	27m 20s	lpagliei@agora.org	Presenter
Renee Perri	"8/24/21, 3:00:58 PM"	"8/24/21, 3:28:16 PM"	27m 17s	rperri@agora.org	Presenter
Gina Rodriguez	"8/24/21, 3:01:04 PM"	"8/24/21, 3:28:22 PM"	27m 17s	grodriguez@agora.org	Presenter
Dana Pacolay	"8/24/21, 3:01:23 PM"	"8/24/21, 3:28:48 PM"	27m 25s	dpacolay@agora.org	Presenter
Chelsey Panchura	"8/24/21, 3:01:29 PM"	"8/24/21, 3:28:42 PM"	27m 13s	cpanchura@agora.org	Presenter
Kymerly Humanick	"8/24/21, 3:01:31 PM"	"8/24/21, 3:28:23 PM"	26m 51s	khumanick@agora.org	Presenter
Valerie Natale	"8/24/21, 3:01:41 PM"	"8/24/21, 3:29:17 PM"	27m 36s	vnatale@agora.org	Presenter
Patrick Lavelle	"8/24/21, 3:01:48 PM"	"8/24/21, 3:28:20 PM"	26m 32s	plavelle@agora.org	Presenter
Janelle Shaffer	"8/24/21, 3:01:48 PM"	"8/24/21, 3:28:20 PM"	26m 32s	jshaffer3@agora.org	Presenter
Kaelyn Hoffman	"8/24/21, 3:01:55 PM"	"8/24/21, 3:28:44 PM"	26m 48s	khoffman@agora.org	Presenter
Heidi Dodge	"8/24/21, 3:02:23 PM"	"8/24/21, 3:28:31 PM"	26m 8s	hdodge@agora.org	Presenter
Erin Scrip	"8/24/21, 3:02:24 PM"	"8/24/21, 3:17:29 PM"	15m 5s	escrip@agora.org	Presenter
Erin Scrip	"8/24/21, 3:20:42 PM"	"8/24/21, 3:34:19 PM"	13m 37s	escrip@agora.org	Presenter
Julie Doebereiner	"8/24/21, 3:03:14 PM"	"8/24/21, 3:35:44 PM"	32m 29s	jdoebereiner@agora.org	Presenter
Olivia Eckels	"8/24/21, 3:04:33 PM"	"8/24/21, 3:28:25 PM"	23m 51s	oeckels@agora.org	Presenter
Danielle Schall	"8/24/21, 3:04:57 PM"	"8/24/21, 3:28:26 PM"	23m 28s	dschall@agora.org	Presenter
Sasha Young	"8/24/21, 3:05:09 PM"	"8/24/21, 3:28:21 PM"	23m 11s	syoung@agora.org	Presenter
Lauren Radico	"8/24/21, 3:05:25 PM"	"8/24/21, 3:29:20 PM"	23m 54s	lradico@agora.org	Presenter
Heather Gallagher	"8/24/21, 3:05:43 PM"	"8/24/21, 3:30:28 PM"	24m 45s	hgallagher@agora.org	Presenter
Erin Connor	"8/24/21, 3:06:23 PM"	"8/24/21, 3:11:02 PM"	4m 39s	econnor@agora.org	Presenter
Whitney Bargerstock	"8/24/21, 3:07:41 PM"	"8/24/21, 3:30:56 PM"	23m 14s	wbargerstock@agora.org	Presenter
Kimberly Fiscus	"8/24/21, 3:07:46 PM"	"8/24/21, 3:28:19 PM"	20m 32s	kfiscus@agora.org	Presenter
Colleen Freyvogel Bruss	"8/24/21, 3:08:58 PM"	"8/24/21, 3:28:22 PM"	19m 23s	cfreyvogel@agora.org	Presenter

Mindy Wesley "8/24/21, 3:13:21 PM""8/24/21, 3:14:30 PM"1m 9s mwesley@agora.org Presenter  
Christine Thomas "8/24/21, 3:15:15 PM""8/24/21, 3:28:24 PM"13m 8s cthomas@agora.org  
Presenter  
Erinn Slacktish "8/24/21, 3:15:21 PM""8/24/21, 3:28:21 PM"13m eslacktish@agora.org Presenter  
Kimberly McLaughlin "8/24/21, 3:26:26 PM""8/24/21, 3:28:31 PM"2m 5s kmclaughlin@agora.org  
Presenter



# T4-Agora Cyber Charter-Basics Training Webinar w.Kristina

Created by: sinnes@jigsawlearning.com · Your response: ✓Yes, I'm going

## Time

1pm - 4pm (Eastern Time - New York)

## Date

Mon Aug 31, 2020

## Description

T4-Agora Cyber Charter-PA Basics Training  
Webinar w.Kristina  
Mon, Aug 31, 2020 1:00 PM - 4:00 PM (EDT)  
55 student licenses expire 8/31/2021  
Maryann is Agoras tt admin

1.5 hours each of Basics and enCORE

Please join my meeting from your computer, tablet or smartphone. If the link is not accessible please copy and paste into any web browser.

<https://global.gotomeeting.com/join/276964709>

Please dial into the conference portion of the webinar using the Phone Number and Access Code provided below:

United States: +1 (669) 224-3412

Access Code: 276-964-709

Join from a video-conferencing room or system.  
Dial in or type: 67.217.95.2 or [inroomlink.goto.com](https://inroomlink.goto.com)  
Meeting ID: 276 964 709  
Or dial directly: 276964709@67.217.95.2 or  
67.217.95.2##276964709

## Guests

- ✓ [alanglais@teachtown.com](mailto:alanglais@teachtown.com)
- ✓ [aphillips@teachtown.com](mailto:aphillips@teachtown.com)
- ✓ Brett Stevens
- ✓ Chelsey Panchura
- ✓ Jesse Capitano
- ✓ Jen Lucia
- ✓ Laurie Super
- ✓ MARYANN JOHNSON
- ✓ MICHELLE CUKAUSKAS
- ✓ NICOLE KROL
- ✓ [pd@jigsawlearning.com](mailto:pd@jigsawlearning.com)
- ✓ Renee Perri
- ☉ Melissa Hale-Patterson
- Ashley Farster
- ANNA LEPSCH
- ASHLEY SCHMIDT
- Amber Staley
- Brianna Pontious
- CATHRYN MACK
- David Furka
- Dana O'Donnell
- Heather Cobert
- Jennifer Beeken
- Jennifer Cadieux
- JANELLE SHAFFER
- Kelly Berstecher
- [kcracknell@teachtown.com](mailto:kcracknell@teachtown.com)
- KIMBERLY FISCUS

New to GoToMeeting? Get the app now and be ready when your first meeting starts:  
<https://global.gotomeeting.com/install/276964709>

## AGENDA

1.5 hours - Basics - Introduction, Program Implementation, Adding Facilitators, Report Running, Goal Setting

1.5 hours - enCORE - Introduction, Standards Alignment, Implementation, Basics Alignment

My Notes

# Agenda

- Introduction to MobyMax
- Placement Tests & How to Assign
- Modules for ELA & Math
- Progress Monitoring & Progress Reports
- Goals
- Monitoring Student Progress
- Q&A

Session Name	Moby Max Progress Monitoring
Session Type	Small Group
Instructional Level	General
Session Owner	Lapsker, Kristina
Teacher	Lapsker, Kristina
Subject	Other
Unit / Lesson	
Program(s)	None
Date and Time	Fri 06/11/2021, 01:00pm-02:00pm (EDT)
Number of Required and Optional Participants	100%
Participation Rate of Required and Optional Participants	100%
Number of Required Participants	100%
Participation Rate of Required Participants	100%
Number of Guests	3600%
Course Codes	
Course Names	

# Today's Objectives



## This session will:



- Cover IEP Writing Guide
- Distribute updated IEP Writing Guide and 2020-2021 IEP Analysis form
- Provide Measurable Annual Goal writing training

Timestamp	Email Address	Name	PPID	Supervisor	
8/11/2020 16:09:17	eslacktish@agora.org	First Name	Last Name	ANSWER KEY	
8/10/2020 16:17:54	bfroehlich@agora.org	Brittany	Froehlich	5897815	Lucia
8/11/2020 9:47:35	lolbryk@agora.org	Lacey	Olbryk	8725401	Lucia
8/11/2020 14:10:36	asweeney@agora.org	Allison	Sweeney	6797603	Natale
8/11/2020 14:39:46	cmack@agora.org	Cathryn	Mack	9457194	Johnson
8/11/2020 15:46:09	twalker@agora.org	Tara	Walker		Schall
8/11/2020 22:22:43	lsvonavec@agora.org	Lauren	Svonavec	6873915	Johnson
8/12/2020 7:39:19	bscears@agora.org	Breanne	Scears	2918713	Val Natale
8/12/2020 9:11:40	jshaffer3@agora.org	Janelle	Shaffer	1783096	Freyvogel
8/12/2020 9:15:59	kbeadle@agora.org	Karla	Beadle		Cukauskas
8/12/2020 12:09:49	jdepietro@agora.org	Jenn	DePietro	1051274	Witman
8/12/2020 12:35:02	jdeemer@agora.org	Judy	Deemer		Natale
8/12/2020 15:02:45	jbeeken@agora.org	Jennifer	Beeken	1431604	Freyvogel
8/12/2020 20:06:27	bcantwell@agora.org	Brittney	Cantwell	6989082	Johnson
8/13/2020 10:07:21	svietmeier@agora.org	Stacy	Vietmeier	5735753	Johnson
8/13/2020 10:45:26	aschmidt@agora.org	Ashley	Schmidt	6546756	Cukauskas
8/13/2020 11:28:25	cbarkley@agora.org	Cortney	Barkley	9674013	Lucia
8/13/2020 13:36:30	lstapf@agora.org	Laura	Stapf	5026504	Natale
8/13/2020 13:59:15	chartman@agora.org	Cathrine	Hartman	3606539	Cukauskas
8/13/2020 15:48:05	slelko@agora.org	Susan	Lelko	9089175	Natale
8/13/2020 15:48:19	nreimers@agora.org	Nancy	Reimers	6041706	Schall
8/14/2020 13:51:48	rperri@agora.org	Renee	Perri	1810325	Natale
8/14/2020 14:24:45	cganter@agora.org	Crysta	Ganter	1673067	Cukauskas
8/14/2020 17:38:21	lbrestensky@agora.org	Lisa	Brestensky	8491596	Freyvogel
8/14/2020 22:27:50	jreese@agora.org	Jessica	Reese	5207967	Lucia
8/17/2020 8:13:08	ckirchner@agora.org	Carly	Kirchner	6725723	Freyvogel



<b>Timestamp</b>	<b>Email Address</b>	<b>Name</b>		<b>PPID</b>	<b>Supervisor</b>
8/17/2020 10:45:27	cbryan@agora.org	Carol	Bryan	6408509	Cukauskas
8/17/2020 13:10:54	jfecik@agora.org	Justine	Fecik	1607938	Schall
8/17/2020 13:37:32	dfurka@agora.org	David	Furka	5839145	Johnson
8/17/2020 13:39:05	jhuffman@agora.org	Jena	Huffman	7165636	Natale
8/17/2020 20:06:34	klapsker@agora.org	Kristina	Lapsker		
8/18/2020 11:05:17	aarmstrong@agora.org	Amanda	Armstrong	1830841	Freyvogel
8/18/2020 11:05:19	mgaso@agora.org	Melissa	Gaso	1678431	Natale
8/18/2020 11:48:33	nkrol@agora.org	Nicole	Krol	8487304	Freyvogel
8/18/2020 12:19:35	kfitzgerald@agora.org	Kim	Fitzgerald	7953824	Lucia
8/18/2020 13:35:37	jdunlap@agora.org	Jill	Dunlap	3951391	Freyvogel
8/18/2020 13:39:38	lradico@agora.org	Lauren	Radico	5674767	Freyvogel
8/18/2020 13:57:21	dodonnell@agora.org	Dana	O'Donnell	5397505	Johnson
8/18/2020 15:21:25	oeckels@agora.org	Olivia	Eckels	1835849	Cukauskas
8/18/2020 15:38:49	slipiec@agora.org	Susan	Lipiec	7462653	Lucia
8/18/2020 15:51:27	jcapitano@agora.org	Jesse	Capitano	8981801	Freyvogel
8/18/2020 16:32:45	mstump@agora.org	Melissa	Stump	8359342	Natale
8/18/2020 17:23:11	adenham@agora.org	Angie	Denham	5837679	Witman
8/18/2020 19:19:32	kcostanzo@agora.org	Kristal	Costanzo	4721493	Lucia
8/19/2020 12:29:00	cpanchura@agora.org	Chelsey	Panchura	5735207	Freyvogel
8/19/2020 13:04:57	lspratt@agora.org	Leslie	Spratt	2579716	Johnson
8/19/2020 13:28:28	kwelsh@agora.org	Kristy	Welsh	3715812	Natale
8/19/2020 14:04:01	thunkele@agora.org	Terri	Hunkele	7871924	Schall
8/19/2020 14:17:41	jdietrich@agora.org	Jenna	Dietrich	4096064	Lucia
8/19/2020 18:33:36	astaley2@agora.org	Amber	Staley	2865256	Freyvogel
8/19/2020 20:04:12	mpelissier@agora.org	Michelle	Pelissier	1391528	Johnson
8/19/2020 20:59:44	hsilberman@agora.org	Heather	Silberman		Schall

<b>Timestamp</b>	<b>Email Address</b>	<b>Name</b>		<b>PPID</b>	<b>Supervisor</b>
8/19/2020 21:11:16	jmoyer2@agora.org	Jill	Moyer		Schall
8/20/2020 13:30:53	rcongdon@agora.org	Rebekah	Congdon	5045706	Schall
8/20/2020 21:31:40	jbarnhart@agora.org	Jessica	Barnhart	4590197	Lucia
8/21/2020 9:26:40	mlove@agora.org	Melissa	Love	1097861	Schall
8/21/2020 9:50:17	tdraeger@agora.org	Theresa	Draeger	1585189	Schall
8/21/2020 12:44:58	jzollman@agora.org	Jennifer	Zollman	8725829	Natale
8/21/2020 23:42:12	mgarczynski@agora.org	Molly	Garczynski	8048158	Johnson
8/22/2020 10:20:46	alarge@agora.org	Allison	Large	7934971	Freyvogel
8/22/2020 13:49:32	skennedy@agora.org	Sabrina	Kennedy	8258565	Natale
8/23/2020 10:02:27	lkerns@agora.org	Lauren	Kerns	6463102	Natale
8/23/2020 16:54:22	syounng@agora.org	Sasha	Young	6136347	Schall
8/23/2020 17:39:05	amalec@agora.org	Ashley	Malec	1652126	Lucia
8/23/2020 17:46:49	dpacolay@agora.org	Dana	Pacolay	5325374	Freyvogel
8/23/2020 18:00:49	jseverino@agora.org	Jill	Severino	1205208	Lucia
8/23/2020 20:09:34	abrisbane@agora.org	Amber	Brisbane	3612063	Witman
8/24/2020 4:47:10	hcobert@agora.org	Heather	Cobert	4102713	Freyvogel
8/24/2020 9:26:21	cemrick@agora.org	Carissa	Emrick	5403689	Schall
8/24/2020 10:02:30	jbuss@agora.org	Jennifer	Buss	5732496	Cukauskas
8/24/2020 10:23:14	lpagliei@agora.org	Lynn	Pagliei	3109573	Schall
8/24/2020 10:30:20	gmallon@agora.org	Regina	Mallon	1907396	Cukauskas
8/24/2020 10:31:07	afarster@agora.org	Ashley	Farster	2480142	Cukauskas
8/24/2020 11:20:45	tambuka@agora.org	Tracey	Ambuka	2941592	Freyvogel
8/24/2020 14:47:00	akimimage@agora.org	Amanda	Moyer	3056185	Schall
8/24/2020 15:18:03	gfiscus@agora.org	Grace	Fiscus	8105219	Cukauskas
8/24/2020 16:55:32	cbaker@agora.org	Chris	Baker	6760832	Lucia
8/24/2020 19:29:17	kpaolino@agora.org	Kim	Paolino	3172707	Johnson

<b>Timestamp</b>	<b>Email Address</b>	<b>Name</b>		<b>PPID</b>	<b>Supervisor</b>
8/24/2020 20:00:40	jlinderman@agora.org	Jessica	Linderman	9045025	Johnson
8/24/2020 20:06:37	cwiddop@agora.org	Christen	Widdop	6597585	Cukauskas
8/24/2020 20:12:17	bpontious@agora.org	Brianna	Pontious	9616535	Lucia
8/24/2020 21:35:20	bfink@agora.org	Brittany	Fink	9891649	Johnson
8/24/2020 23:34:43	jdoebereiner@agora.org	Julie	Doebereiner	7489562	Lucia
8/25/2020 7:09:21	lsavitz@agora.org	Lisa	Savitz	6402734	Schall
8/25/2020 7:51:17	lsavitz@agora.org	Lisa	Savitz	6402734	Schall
8/25/2020 8:16:48	gdonch@agora.org	Gina	Rodriguez	3791683	Cukauskas
8/25/2020 14:24:16	jcadieux@agora.org	Jenn	Cadieux	2746171	Freyvogel
8/25/2020 15:32:19	hdodge@agora.org	Heidi	Dodge	2569601	Johnson
8/26/2020 12:28:55	cramsey@agora.org	Cathryn	Ramsey	8190103	Lucia
8/26/2020 12:32:17	ehenretta@agora.org	Erikka	Henretta	1872897	Cukauskas
8/26/2020 12:45:28	mbasso@agora.org	Maura	Basso	6941361	Lucia
8/31/2020 13:21:53	mbotti@agora.org	Michelle	Botti	9294146	Lucia
9/1/2020 13:51:36	khoffman@agora.org	Kaelyn	Hoffman	5371396	Lucia
9/3/2020 10:23:57	kshannon@agora.org	Keri	Shannon	5341385	Natale
9/7/2020 13:21:15	bcooper@agora.org	Barb	Cooper		Schall
9/8/2020 11:11:54	mmccracken@agora.org	Melissa	McCracken	7467268	Freyvogel
9/15/2020 9:25:05	llamison@agora.org	Lauren Lamison		9614984	Natale
9/15/2020 9:46:24	scostello@agora.org	Serena Costello		6237909	Natale
9/15/2020 11:00:20	nhollenbach@agora.org	Nicolette Hollenbach		5776786	Natale
9/16/2020 15:45:42	araught@agora.org	Amy Raught		4603802	Freyvogel
9/16/2020 22:36:17	tkozak@agora.org	Tamara Kozak		2986176	Natale
9/29/2020 11:14:06	hgallagher@agora.org	Heather Gallagher		7959715	Natale
10/8/2020 16:17:43	akammermeier@agora.org	Amanda Kammermeier		2010834	Natale

What is one example of a formative assessment?	Academic goals have a standard, anchor, or element from the curriculum framework. This standard should:	Related service goals	Performance criteria does not include	When setting up your sub folder what is something you should not include?	For substitute coverage I have to do the following at least 48 hours in advance:
Classroom test scores	should be on the student's	Must have all 4 parts of th	clearly defined behavior	prior year's information	Create a folder with less
Classroom test scores	should be on the student's	Must have all 4 parts of th	clearly defined behavior	prior year's information	Create a folder with less
CDT	should be on the student's	Must have all 4 parts of th	clearly defined behavior	prior year's information	Email subrequest with dat
Classroom test scores	should be on the student's	Must have all 4 parts of th	clearly defined behavior	prior year's information	Email subrequest with dat
CDT	should be on the student's	Must have all 4 parts of th	an evaluation schedule	prior year's information	Email subrequest with dat
Classroom test scores	always be on the student's	Must have all 4 parts of th	clearly defined behavior	prior year's information	Create a folder with less
Classroom test scores	should be on the student's	Must have all 4 parts of th	clearly defined behavior	prior year's information	Email subrequest with dat
Classroom test scores	should be on the student's	Must have all 4 parts of th	the level of mastery	prior year's information	Create a folder with less
Classroom test scores	should be on the student's	Must have all 4 parts of th	clearly defined behavior	prior year's information	Create slides for the less
CDT	always be on the student's	Must have all 4 parts of th	clearly defined behavior	prior year's information	Create a folder with less
Classroom test scores	always be on the student's	Must have all 4 parts of th	clearly defined behavior	prior year's information	Create a folder with less
CDT	should be on the student's	Must have all 4 parts of th	clearly defined behavior	prior year's information	Email subrequest with dat
Classroom test scores	should be on the student's	Must have all 4 parts of th	clearly defined behavior	prior year's information	Create a folder with less
Classroom test scores	should be on the student's	Must have all 4 parts of th	clearly defined behavior	prior year's information	Email subrequest with dat
Classroom test scores	should be on the student's	Must have all 4 parts of th	clearly defined behavior	prior year's information	Email subrequest with dat
Classroom test scores	should be on the student's	Must have all 4 parts of th	number of times needed t	prior year's information	Create slides for the less
Classroom test scores	should be on the student's	Must have all 4 parts of th	clearly defined behavior	prior year's information	Create slides for the less
Classroom test scores	always be on the student's	Must have all 4 parts of th	an evaluation schedule	prior year's information	Email subrequest with dat
Classroom test scores	should be on the student's	Must have all 4 parts of th	clearly defined behavior	prior year's information	Create slides for the less
Classroom test scores	should be on the student's	Must have 3 parts of the l	an evaluation schedule	prior year's information	Create a folder with less
Classroom test scores	should be on the student's	Must have all 4 parts of th	clearly defined behavior	prior year's information	Email subrequest with dat
Classroom test scores	should be on the student's	Must have all 4 parts of th	clearly defined behavior	prior year's information	Email subrequest with dat
CDT	should be on the student's	Must have all 4 parts of th	an evaluation schedule	prior year's information	Email subrequest with dat
Classroom test scores	should be on the student's	Must have all 4 parts of th	clearly defined behavior	prior year's information	Create a folder with less
Classroom test scores	should be on the student's	Must have all 4 parts of th	clearly defined behavior	prior year's information	Email subrequest with dat
Classroom test scores	should be on the student's	Must have all 4 parts of th	clearly defined behavior	prior year's information	Create a folder with less
Classroom test scores	should be on the student's	Must have all 4 parts of th	clearly defined behavior	prior year's information	Create slides for the less



What is one example of a formative assessment?	Academic goals have a standard, anchor, or element from the curriculum framework. This standard should:	Related service goals	Performance criteria does not include	When setting up your sub folder what is something you should not include?	For substitute coverage I have to do the following at least 48 hours in advance:
Classroom test scores	should be on the student's	Must have all 4 parts of th	clearly defined behavior	prior year's information	Email subrequest with dat
Classroom test scores	should be on the student's	Must have all 4 parts of th	an evaluation schedule	prior year's information	Create slides for the lessc
Classroom test scores	should be on the student's	Must have all 4 parts of th	clearly defined behavior	prior year's information	Create slides for the lessc
CDT	should be on the student's	Must have all 4 parts of th	clearly defined behavior	prior year's information	Email subrequest with dat
CDT	always be on the student's	Must have all 4 parts of th	an evaluation schedule	prior year's information	Create a folder with lessc
Classroom test scores	always be on the student's	Must have all 4 parts of th	clearly defined behavior	prior year's information	Email subrequest with dat
CDT	should be on the student's	Must have all 4 parts of th	an evaluation schedule	prior year's information	Create slides for the lessc
CDT	always be on the student's	Must have 3 parts of the	number of times needed t	prior year's information	Create slides for the lessc
Classroom test scores	should be on the student's	Must have all 4 parts of th	clearly defined behavior	prior year's information	Create a folder with lessc
CDT	should be on the student's	Must have all 4 parts of th	clearly defined behavior	prior year's information	Email subrequest with dat
Classroom test scores	should be on the student's	Must have all 4 parts of th	clearly defined behavior	prior year's information	Email subrequest with dat
Classroom test scores	should be on the student's	Must have all 4 parts of th	an evaluation schedule	prior year's information	Email subrequest with dat
Classroom test scores	should be on the student's	Must have all 4 parts of th	an evaluation schedule	prior year's information	Create slides for the lessc
Classroom test scores	should be on the student's	Must have all 4 parts of th	clearly defined behavior	prior year's information	Email subrequest with dat
Classroom test scores	should be on the student's	Must have all 4 parts of th	clearly defined behavior	prior year's information	Create a folder with lessc
Classroom test scores	should be on the student's	Must have all 4 parts of th	clearly defined behavior	prior year's information	Email subrequest with dat
CDT	should be on the student's	Must have 3 parts of the	an evaluation schedule	prior year's information	Create slides for the lessc
PSSAs	should be on the student's	Must have all 4 parts of th	clearly defined behavior	prior year's information	Create slides for the lessc
Classroom test scores	should be on the student's	Must have all 4 parts of the	MAG criteria or it is inco	prior year's information	Create slides for the lessc
Classroom test scores	should be on the student's	Must have all 4 parts of th	an evaluation schedule	prior year's information	Email subrequest with dat
Classroom test scores	should be on the student's	Must have all 4 parts of th	an evaluation schedule	prior year's information	Email subrequest with dat
Classroom test scores	should be on the student's	Do not always need to be	clearly defined behavior	prior year's information	I prefer not to have a sub
Classroom test scores	should be on the student's	Must have all 4 parts of th	clearly defined behavior	prior year's information	Create a folder with lessc
Classroom test scores	should be on the student's	Must have all 4 parts of th	an evaluation schedule	prior year's information	Email subrequest with dat
Classroom test scores	should be on the student's	Must have all 4 parts of th	clearly defined behavior	prior year's information	Create a folder with lessc
Classroom test scores	should be on the student's	Must have all 4 parts of th	an evaluation schedule	prior year's information	Email subrequest with dat

What is one example of a formative assessment?	Academic goals have a standard, anchor, or element from the curriculum framework. This standard should:	Related service goals	Performance criteria does not include	When setting up your sub folder what is something you should not include?	For substitute coverage I have to do the following at least 48 hours in advance:
PSSAs	should be on the student's	Must have 3 parts of the	1 clearly defined behavior	prior year's information	Email subrequest with dat
Classroom test scores	should be on the student's	Must have all 4 parts of th	an evaluation schedule	prior year's information	Create a folder with less
Classroom test scores	should be on the student's	Must have all 4 parts of th	clearly defined behavior	prior year's information	Email subrequest with dat
Classroom test scores	should be on the student's	Must have all 4 parts of th	an evaluation schedule	prior year's information	Create a folder with less
Classroom test scores	should be on the student's	Must have all 4 parts of th	clearly defined behavior	prior year's information	Create slides for the less
CDT	should be on the student's	Must have all 4 parts of th	clearly defined behavior	prior year's information	Email subrequest with dat
CDT	should be on the student's	Must have all 4 parts of th	clearly defined behavior	prior year's information	Email subrequest with dat
Classroom test scores	should be on the student's	Must have all 4 parts of th	an evaluation schedule	prior year's information	I prefer not to have a sub
Classroom test scores	should be on the student's	Must have all 4 parts of th	an evaluation schedule	prior year's information	I prefer not to have a sub
Classroom test scores	should be on the student's	Must have all 4 parts of th	an evaluation schedule	prior year's information	Email subrequest with dat
Classroom test scores	always be on the student's	Must have 3 parts of the	1 clearly defined behavior	prior year's information	Email subrequest with dat
Classroom test scores	should be on the student's	Must have all 4 parts of th	clearly defined behavior	prior year's information	Create a folder with less
Classroom test scores	should be on the student's	Must have all 4 parts of th	an evaluation schedule	prior year's information	Email subrequest with dat
Classroom test scores	always be on the student's	Must have all 4 parts of th	number of times needed t	prior year's information	Create a folder with less
Classroom test scores	should be on the student's	Must have all 4 parts of th	clearly defined behavior	prior year's information	Create a folder with less
Classroom test scores	should be on the student's	Must have all 4 parts of th	clearly defined behavior	prior year's information	Email subrequest with dat
Classroom test scores	should be on the student's	Must have all 4 parts of th	an evaluation schedule	prior year's information	Create a folder with less
Classroom test scores	should be on the student's	Must have all 4 parts of th	an evaluation schedule	prior year's information	Email subrequest with dat
CDT	should be on the student's	Must have all 4 parts of the	MAG criteria or it is inco	prior year's information	Email subrequest with dat
CDT	should be on the student's	Must have all 4 parts of th	an evaluation schedule	prior year's information	Email subrequest with dat
CDT	always be on the student's	Must have all 4 parts of th	clearly defined behavior	prior year's information	Email subrequest with dat
Classroom test scores	always be on the student's	Must have all 4 parts of th	clearly defined behavior	login info for TV/K12	Email subrequest with dat
Classroom test scores	should be on the student's	Must have 3 parts of the	1 the level of mastery	prior year's information	Create a folder with less
Classroom test scores	always be on the student's	Must have all 4 parts of th	number of times needed t	prior year's information	Email subrequest with dat
Classroom test scores	always be on the student's	Must have all 4 parts of th	clearly defined behavior	prior year's information	Email subrequest with dat

**If a student needs special materials listed in his/her IEP such as print materials, enlargements, or access to a curriculum I should:**

**IEPs do not need to be held if:**

**A student should have a NEW baseline if:**

**A full team meeting is needed for a SAIP when:**

n plan info.	Submit the special educational	the IEP is compliant, the	€ All of the above are reason	it now always needs to be
n plan info.	Email my supervisor with	the IEP is compliant, the	€ All of the above are reason	it now always needs to be
es, times, and the name of the classes in which I nee	Submit the special educational	the IEP is compliant, the	€ All of the above are reason	it now always needs to be
es, times, and the name of the classes in which I nee	Submit the special educational	the IEP is compliant, the	€ All of the above are reason	it now always needs to be
es, times, and the name of the classes in which I nee	Submit the special educational	the IEP is compliant, the	€ All of the above are reason	it now always needs to be
n plan info.	Submit the special educational	the IEP is compliant, the	€ All of the above are reason	it now always needs to be
es, times, and the name of the classes in which I nee	Submit the special educational	the IEP is compliant, the	€ All of the above are reason	it now always needs to be
n plan info.	Submit the special educational	the parent doesn't prefer	€ All of the above are reason	it now always needs to be
on that include answers to the problems	Submit the special educational	the IEP is compliant, the	€ All of the above are reason	it now always needs to be
n plan info.	Submit the special educational	the IEP is compliant, the	€ All of the above are reason	it now always needs to be
n plan info.	Submit the special educational	the IEP is compliant, the	€ The student is not making it	now always needs to be
es, times, and the name of the classes in which I nee	Submit the special educational	the IEP is compliant, the	€ All of the above are reason	only when it's the third me
n plan info.	Submit the special educational	the IEP is compliant, the	€ All of the above are reason	it now always needs to be
es, times, and the name of the classes in which I nee	Submit the special educational	the IEP is compliant, the	€ The data is more than 6 m	it now always needs to be
on that include answers to the problems	Submit the special educational	the IEP is compliant, the	€ All of the above are reason	it now always needs to be
on that include answers to the problems	Email my supervisor with	the IEP is compliant, the	€ The data is more than 6 m	it now always needs to be
es, times, and the name of the classes in which I nee	Submit the special educational	the IEP is compliant, the	€ All of the above are reason	it now always needs to be
on that include answers to the problems	Submit the special educational	the IEP is compliant, the	€ All of the above are reason	it now always needs to be
n plan info.	Submit the special educational	the IEP is compliant, the	€ The data is more than 6 m	it now always needs to be
es, times, and the name of the classes in which I nee	Submit the special educational	the IEP is compliant, the	€ The data is more than 6 m	it now always needs to be
es, times, and the name of the classes in which I nee	Submit the special educational	the IEP is compliant, the	€ The data is more than 6 m	it now always needs to be
es, times, and the name of the classes in which I nee	Email my supervisor with	the IEP is compliant, the	€ All of the above are reason	it now always needs to be
n plan info.	Submit the special educational	the IEP is compliant, the	€ All of the above are reason	it now always needs to be
es, times, and the name of the classes in which I nee	Submit the special educational	the IEP is compliant, the	€ All of the above are reason	it now always needs to be
n plan info.	Submit the special educational	the IEP is compliant, the	€ The data is more than 6 m	it now always needs to be
on that include answers to the problems	Submit the special educational	the IEP is compliant, the	€ All of the above are reason	it now always needs to be



**If a student needs special materials listed in his/her IEP such as print materials, enlargements, or access to a curriculum I should:**

**IEPs do not need to be held if:**

**A student should have a NEW baseline if:**

**A full team meeting is needed for a SAIP when:**

on that include answers to the problems	Submit the special educational	the IEP is compliant, the	€ All of the above are reason	it now always needs to be
on that include answers to the problems	Submit the special educational	the IEP is compliant, the	€ All of the above are reason	it now always needs to be
es, times, and the name of the classes in which I need	Submit the special educational	the IEP is compliant, the	€ All of the above are reason	it now always needs to be
n plan info.	Email my supervisor with	the IEP is compliant, the	€ All of the above are reason	it now always needs to be
es, times, and the name of the classes in which I need	Submit the special educational	the IEP is compliant, the	€ All of the above are reason	it now always needs to be
on that include answers to the problems	Submit the special educational	the IEP is compliant, the	€ All of the above are reason	it now always needs to be
on that include answers to the problems	Submit the special educational	the IEP is compliant, the	€ All of the above are reason	it now always needs to be
es, times, and the name of the classes in which I need	Submit the special educational	the IEP is compliant, the	€ All of the above are reason	it now always needs to be
es, times, and the name of the classes in which I need	Submit the special educational	the IEP is compliant, the	€ All of the above are reason	it now always needs to be
on that include answers to the problems	Submit the special educational	the IEP is compliant, the	€ The data is more than 6 m	n it now always needs to be
on that include answers to the problems	Submit the special educational	the IEP is compliant, the	€ The data is more than 6 m	n it now always needs to be
es, times, and the name of the classes in which I need	Submit the special educational	the IEP is compliant, the	€ All of the above are reason	it now always needs to be
es, times, and the name of the classes in which I need	Submit the special educational	the parent doesn't prefer	€ All of the above are reason	only when it's the third me
es, times, and the name of the classes in which I need	Email my supervisor with	the IEP is compliant, the	€ The data is more than 6 m	n it now always needs to be
on that include answers to the problems	Submit the special educational	the IEP is compliant, the	€ All of the above are reason	it now always needs to be
n plan info.	Submit the special educational	the IEP is compliant, the	€ The data is more than 6 m	n it now always needs to be
n plan info.	Submit the special educational	the IEP is compliant, the	€ All of the above are reason	it now always needs to be
n plan info.	Submit the special educational	the IEP is compliant, the	€ The data is more than 6 m	n it now always needs to be
n plan info.	Submit the special educational	the IEP is compliant, the	€ The data is more than 6 m	n it now always needs to be
on that include answers to the problems	Submit the special educational	it's an RR since those onl	The data is more than 6 m	n it now always needs to be
es, times, and the name of the classes in which I need	Submit the special educational	the parent doesn't prefer	€ All of the above are reason	only when it's the third me
on that include answers to the problems	Submit the special educational	the IEP is compliant, the	€ All of the above are reason	it now always needs to be
es, times, and the name of the classes in which I need	Submit the special educational	the IEP is compliant, the	€ All of the above are reason	it now always needs to be
on that include answers to the problems	Submit the special educational	the IEP is compliant, the	€ All of the above are reason	it now always needs to be
n plan info.	Submit the special educational	the IEP is compliant, the	€ The data is more than 6 m	n it now always needs to be
n plan info.	Submit the special educational	the IEP is compliant, the	€ All of the above are reason	it now always needs to be



**If a student needs special materials listed in his/her IEP such as print materials, enlargements, or access to a curriculum I should:**

**IEPs do not need to be held if:**

**A student should have a NEW baseline if:**

**A full team meeting is needed for a SAIP when:**

es, times, and the name of the classes in which I need to provide this information on my IEP	Submit the special education IEP if the IEP is compliant, the data is more than 6 months old	Submit the special education IEP if the IEP is compliant, the data is more than 6 months old	All of the above are reasonable	it now always needs to be held
es, times, and the name of the classes in which I need to provide this information on my IEP	Submit the special education IEP if the IEP is compliant, the data is more than 6 months old	Submit the special education IEP if the IEP is compliant, the data is more than 6 months old	All of the above are reasonable	it now always needs to be held
on that include answers to the problems	Submit the special education IEP if the IEP is compliant, the data is more than 6 months old	Submit the special education IEP if the IEP is compliant, the data is more than 6 months old	All of the above are reasonable	only when it's the second meeting
es, times, and the name of the classes in which I need to provide this information on my IEP	Submit the special education IEP if the IEP is compliant, the data is more than 6 months old	Submit the special education IEP if the IEP is compliant, the data is more than 6 months old	The data is more than 6 months old	only when it's the third meeting
so I just need to let my supervisor know I'm pushing for this	Email my supervisor with the IEP	Submit the special education IEP if the IEP is compliant, the data is more than 6 months old	The data is more than 6 months old	it now always needs to be held
so I just need to let my supervisor know I'm pushing for this	Submit the special education IEP if it's an RR since those are not held	Submit the special education IEP if the IEP is compliant, the data is more than 6 months old	All of the above are reasonable	it now always needs to be held
es, times, and the name of the classes in which I need to provide this information on my IEP	Submit the special education IEP if the IEP is compliant, the data is more than 6 months old	Submit the special education IEP if the IEP is compliant, the data is more than 6 months old	All of the above are reasonable	it now always needs to be held
es, times, and the name of the classes in which I need to provide this information on my IEP	Submit the special education IEP if the IEP is compliant, the data is more than 6 months old	Submit the special education IEP if the IEP is compliant, the data is more than 6 months old	All of the above are reasonable	only when it's the third meeting
es, times, and the name of the classes in which I need to provide this information on my IEP	Submit the special education IEP if the IEP is compliant, the data is more than 6 months old	Submit the special education IEP if the IEP is compliant, the data is more than 6 months old	The data is more than 6 months old	it now always needs to be held
es, times, and the name of the classes in which I need to provide this information on my IEP	Submit the special education IEP if it's an RR since those are not held	Submit the special education IEP if the IEP is compliant, the data is more than 6 months old	All of the above are reasonable	it now always needs to be held
es, times, and the name of the classes in which I need to provide this information on my IEP	Submit the special education IEP if the IEP is compliant, the data is more than 6 months old	Submit the special education IEP if the IEP is compliant, the data is more than 6 months old	The data is more than 6 months old	only when it's the third meeting
es, times, and the name of the classes in which I need to provide this information on my IEP	Submit the special education IEP if the IEP is compliant, the data is more than 6 months old	Submit the special education IEP if the IEP is compliant, the data is more than 6 months old	All of the above are reasonable	it now always needs to be held
es, times, and the name of the classes in which I need to provide this information on my IEP	Submit the special education IEP if the IEP is compliant, the data is more than 6 months old	Submit the special education IEP if the IEP is compliant, the data is more than 6 months old	All of the above are reasonable	it now always needs to be held
es, times, and the name of the classes in which I need to provide this information on my IEP	Submit the special education IEP if the parent doesn't prefer	Submit the special education IEP if the IEP is compliant, the data is more than 6 months old	All of the above are reasonable	it now always needs to be held
es, times, and the name of the classes in which I need to provide this information on my IEP	Submit the special education IEP if a parent asks for a meeting	Submit the special education IEP if the IEP is compliant, the data is more than 6 months old	All of the above are reasonable	it now always needs to be held
es, times, and the name of the classes in which I need to provide this information on my IEP	Submit the special education IEP if the IEP is compliant, the data is more than 6 months old	Submit the special education IEP if the IEP is compliant, the data is more than 6 months old	All of the above are reasonable	it now always needs to be held
es, times, and the name of the classes in which I need to provide this information on my IEP	Submit the special education IEP if the IEP is compliant, the data is more than 6 months old	Submit the special education IEP if the IEP is compliant, the data is more than 6 months old	All of the above are reasonable	when a parent isn't in agreement
es, times, and the name of the classes in which I need to provide this information on my IEP	Submit the special education IEP if the IEP is compliant, the data is more than 6 months old	Submit the special education IEP if the IEP is compliant, the data is more than 6 months old	All of the above are reasonable	it now always needs to be held



<b>Why do I need to complete a related services webform after a SAIP meeting?</b>	<b>Do I need to request ASYNC attendance mode if the student has a doctor's note requesting this?</b>	<b>Where is the best place to obtain therapist contact information?</b>	<b>Where should I document contact with related service providers?</b>	<b>How often should I keep in contact with my student's related service provider?</b>	<b>What norms should be used this year for goal setting?</b>
If the student isn't attending	Maybe. The team has to	Easy Trac	Easy Trac	At least as often as the IE	Winter
If the student isn't attending	Yes, because it's a doctor	Easy Trac	Easy Trac	At least as often as the IE	Winter
The student is being exited	Maybe. The team has to	Easy Trac	Tyler	Weekly	Fall
If the student isn't attending	Maybe. The team has to	Easy Trac	Easy Trac	At least as often as the IE	Winter
If the student isn't attending	Maybe. The team has to	Easy Trac	Easy Trac	Weekly	Winter
If the student isn't attending	Maybe. The team has to	Easy Trac	Easy Trac	At least as often as the IE	Winter
If the student isn't attending	Maybe. The team has to	Easy Trac	Easy Trac	At least as often as the IE	Winter
If the student isn't attending	Maybe. The team has to	Easy Trac	Tyler	Weekly	Fall
If the student isn't attending	Maybe. The team has to	Easy Trac	Easy Trac	Quarterly	Winter
If the student isn't attending	Maybe. The team has to	Easy Trac	Easy Trac	At least as often as the IE	Winter
If the student isn't attending	Maybe. The team has to	Easy Trac	Easy Trac	At least as often as the IE	Winter
I do not need to complete	Maybe. The team has to	Easy Trac	Easy Trac	Quarterly	Winter
If the student isn't attending	Maybe. The team has to	Easy Trac	Easy Trac	At least as often as the IE	Fall
If the student isn't attending	Maybe. The team has to	Easy Trac	Easy Trac	Quarterly	Winter
If the student isn't attending	Maybe. The team has to	Easy Trac	Easy Trac	At least as often as the IE	Winter
If the student isn't attending	Maybe. The team has to	Easy Trac	Easy Trac	Weekly	Winter
The student is being exited	Maybe. The team has to	Easy Trac	Tyler	At least as often as the IE	Fall
If the student isn't attending	Maybe. The team has to	Easy Trac	Easy Trac	At least as often as the IE	Winter
If the student isn't attending	Maybe. The team has to	Easy Trac	Tyler	At least as often as the IE	Winter
If the student isn't attending	Maybe. The team has to	Easy Trac	Tyler	At least as often as the IE	Winter
If the student isn't attending	Maybe. The team has to	Easy Trac	Easy Trac	At least as often as the IE	Fall
If the student isn't attending	Maybe. The team has to	Easy Trac	Tyler	At least as often as the IE	Winter
If the student isn't attending	Maybe. The team has to	Easy Trac	Easy Trac	At least as often as the IE	Winter
If the student isn't attending	Maybe. The team has to	Easy Trac	Easy Trac	Weekly	Winter
If the student isn't attending	Maybe. The team has to	Easy Trac	Tyler	At least as often as the IE	Winter
If the student isn't attending	Maybe. The team has to	Easy Trac	Easy Trac	At least as often as the IE	Winter



<b>Why do I need to complete a related services webform after a SAIP meeting?</b>	<b>Do I need to request ASYNC attendance mode if the student has a doctor's note requesting this?</b>	<b>Where is the best place to obtain therapist contact information?</b>	<b>Where should I document contact with related service providers?</b>	<b>How often should I keep in contact with my student's related service provider?</b>	<b>What norms should be used this year for goal setting?</b>
If the student isn't attending	Maybe. The team has to	Easy Trac	Easy Trac	At least as often as the IE	Winter
If the student isn't attending	Maybe. The team has to	Easy Trac	Tyler	At least as often as the IE	Winter
If the student isn't attending	Maybe. The team has to	Easy Trac	Easy Trac	At least as often as the IE	Winter
If the student isn't attending	Maybe. The team has to	Easy Trac	Easy Trac	At least as often as the IE	Winter
If the student isn't attending	Maybe. The team has to	Easy Trac	Easy Trac	At least as often as the IE	Winter
If the student isn't attending	Maybe. The team has to	Easy Trac	Tyler	At least as often as the IE	Winter
If the student isn't attending	Maybe. The team has to	Easy Trac	Tyler	At least as often as the IE	Winter
If the student isn't attending	Maybe. The team has to	Smartsheet	Easy Trac	Quarterly	Winter
If the student isn't attending	Maybe. The team has to	Easy Trac	Easy Trac	At least as often as the IE	Winter
If the student isn't attending	Maybe. The team has to	Easy Trac		At least as often as the IE	Winter
If the student isn't attending	Maybe. The team has to	Easy Trac	Tyler	Quarterly	Winter
If the student isn't attending	Maybe. The team has to	Easy Trac	Email only	At least as often as the IE	Fall
If the student isn't attending	Maybe. The team has to	Easy Trac	Easy Trac	Quarterly	Spring
The student is being exited	Maybe. The team has to	Easy Trac	Tyler	At least as often as the IE	Winter
If the student isn't attending	Maybe. The team has to	Easy Trac	Tyler	At least as often as the IE	Winter
If the student isn't attending	Maybe. The team has to	Easy Trac	Easy Trac	At least as often as the IE	Winter
If the student isn't attending	Maybe. The team has to	Easy Trac	Tyler	At least as often as the IE	Fall
If the student isn't attending	Maybe. The team has to	Easy Trac	Easy Trac	At least as often as the IE	Winter
If the student isn't attending	Maybe. The team has to	Easy Trac	Easy Trac	Weekly	Winter
I do not need to complete	Maybe. The team has to	Easy Trac	My personal notes	At least as often as the IE	Winter
If the student isn't attending	Yes, because it's a doctor	Easy Trac	Tyler	At least as often as the IE	Spring
If the student isn't attending	Maybe. The team has to	Easy Trac	Easy Trac	At least as often as the IE	Winter
If the student isn't attending	Maybe. The team has to	Easy Trac	Easy Trac	Quarterly	Spring
I do not need to complete	Yes, because it's a doctor	Tyler	Tyler	At least as often as the IE	Fall
If the student isn't attending	Maybe. The team has to	Easy Trac	Easy Trac	At least as often as the IE	Winter





**Why can't you use the goal set slider in AimswebPlus when goal setting for the Classic Measures?**

**All students should be baselined up to the:**

- below average range There are no Student Growth Percentiles loaded.
- well below average range There are no Student Growth Percentiles loaded.
- average range The norms are only based on the LEA norms and not the National norms.
- well below average range There are no Student Growth Percentiles loaded.
- well below average range There are no Student Growth Percentiles loaded.
- frustration level range There are no Student Growth Percentiles loaded.
- frustration level range There are no Student Growth Percentiles loaded.
- frustration level range There are no Student Growth Percentiles loaded.
- well below average range There are no Student Growth Percentiles loaded.
- well below average range There are no Student Growth Percentiles loaded.
- well below average range There are no Student Growth Percentiles loaded.
- frustration level range There are no Student Growth Percentiles loaded.
- well below average range There are no Student Growth Percentiles loaded.
- well below average range There are no Student Growth Percentiles loaded.
- well below average range There are no Student Growth Percentiles loaded.
- well below average range
- average range The norms are only based on the LEA norms and not the National norms.
- well below average range There are no Student Growth Percentiles loaded.
- well below average range There are no Student Growth Percentiles loaded.
- well below average range There are no Student Growth Percentiles loaded.
- frustration level range There are no Student Growth Percentiles loaded.
- well below average range There are no Student Growth Percentiles loaded.
- well below average range You should always use the goal set slider.
- well below average range There are no Student Growth Percentiles loaded.
- well below average range There are no Student Growth Percentiles loaded.
- well below average range There are no Student Growth Percentiles loaded.

**Why can't you use the goal set slider in AimswebPlus when goal setting for the Classic Measures?**

**All students should be baselined up to the:**

- well below average range There are no Student Growth Percentiles loaded.
- well below average range There are no Student Growth Percentiles loaded.
- well below average range There are no Student Growth Percentiles loaded.
- well below average range There are no Student Growth Percentiles loaded.
- frustration level range You should always use the goal set slider.
- well below average range You should always use the goal set slider.
- frustration level range There are no Student Growth Percentiles loaded.
- well below average range There are no Student Growth Percentiles loaded.
- well below average range There are no Student Growth Percentiles loaded.
- well below average range There are no Student Growth Percentiles loaded.
- well below average range There are no Student Growth Percentiles loaded.
- well below average range There are no Student Growth Percentiles loaded.
- below average range There are no Student Growth Percentiles loaded.
- well below average range There are no Student Growth Percentiles loaded.
- well below average range There are no Student Growth Percentiles loaded.
- well below average range There are no Student Growth Percentiles loaded.
- well below average range There are no Student Growth Percentiles loaded.
- frustration level range There are no Student Growth Percentiles loaded.
- well below average range There are no Student Growth Percentiles loaded.
- well below average range There are no Student Growth Percentiles loaded.
- well below average range There are no Student Growth Percentiles loaded.
- frustration level range The norms are only based on the LEA norms and not the National norms.
- well below average range There are no Student Growth Percentiles loaded.
- well below average range There are no Student Growth Percentiles loaded.
- well below average range There are no Student Growth Percentiles loaded.
- average range There are no Student Growth Percentiles loaded.

**Why can't you use the goal set slider in AimswebPlus when goal setting for the Classic Measures?**

**All students should be baselined up to the:**

- well below average range The norms are only based on the LEA norms and not the National norms.
- well below average range There are no Student Growth Percentiles loaded.
- well below average range There are no Student Growth Percentiles loaded.
- well below average range There are no Student Growth Percentiles loaded.
- well below average range The norms are only based on the LEA norms and not the National norms.
- well below average range There are no Student Growth Percentiles loaded.
- well below average range There are no Student Growth Percentiles loaded.
- well below average range You should always use the goal set slider.
- frustration level range There are no Student Growth Percentiles loaded.
- well below average range There are no Student Growth Percentiles loaded.
- well below average range There are no Student Growth Percentiles loaded.
- well below average range The norms are only based on the LEA norms and not the National norms.
- below average range There are no Student Growth Percentiles loaded.
- well below average range There are no Student Growth Percentiles loaded.
- well below average range There are no Student Growth Percentiles loaded.
- well below average range There are no Student Growth Percentiles loaded.
- average range There are no Student Growth Percentiles loaded.
- frustration level range There are no Student Growth Percentiles loaded.
- frustration level range You should always use the goal set slider.
- below average range There are no Student Growth Percentiles loaded.
- frustration level range There are no Student Growth Percentiles loaded.
- well below average range There are no Student Growth Percentiles loaded.
- frustration level range The norms are only based on the LEA norms and not the National norms.
- average range The norms are only based on the LEA norms and not the National norms.
- well below average range There are no Student Growth Percentiles loaded.



# 2022 IEP Team Training

*6/6/2022*

*Presented by  
Danielle Schall &  
Michelle Cukauskas*

# Agenda

- Summer IEP Teams
- Procedure
- Responsibilities
- Timesheet Information
- Crisis Information
- Q&A



# Summer IEP Teams



# K5 Learning Support

K5 Learning Support	
Level	K5 LS
Special Ed. CM	<b>Kristina Lapsker</b>
General Ed. Teacher	Tammy Saad
Level	K5 LS
Special Ed. CM	<b>Stefanie Marcello</b>
General Ed. Teacher	Melissa Erdmann
Level	K5 LS
Special Ed. CM	<b>Carmen Riggle (3)</b>
General Ed. Teacher	Jessi Eberly
Level	K5 LS
Special Ed. CM	<b>Brittany Brown (June)</b>
General Ed. Teacher	Beth Ann Stevens



# K5 Emotional Support & Special Services

K-5 Special Services	
Level	K8 SS
Special Ed. CM	<b>Stacy Vietmeier</b>
General Ed. Teacher	Krista Kowalok
K-5 Emotional Support	
Level	K5 ES
Special Ed. CM	<b>Michelle Pelissier</b>
General Ed. Teacher	Kim Strong





# MS Learning Support

MS Learning Support	
Level	MS LS
Special Ed. CM	<b>Chris Baker</b>
General Ed. Teacher	Heidi Lucier
Level	MS LS
Special Ed. CM	<b>Theresa Bash</b>
General Ed. Teacher	Jared Iampietro
Level	MS LS
Special Ed. CM	<b>Amber Spindler</b>
General Ed. Teacher	Alexandra Webb
Level	MS LS
Special Ed. CM	<b>Susan Lipiec</b>
General Ed. Teacher	Dorry Altman



# MS Emotional Support & Special Services

MS Special Services	
Level	K8 SS
Special Ed. CM	<b>Brianna Pontios</b>
General Ed. Teacher	Barb Harvey
MS Emotional Support	
Level	MS ES
Special Ed. CM	<b>Cathryn Ramsey</b>
General Ed. Teacher	Linda Dupes



# HS Learning Support

HS Learning Support	
Level	HS LS
Special Ed. CM	<b>Allyson Morris</b>
General Ed. Teacher	<i>Sarah Rau</i>
Level	HS LS
Special Ed. CM	<b>Sue Lelko</b>
General Ed. Teacher	<i>Cynthia Shonberg</i>
Level	HS LS
Special Ed. CM	<b>Melissa Love</b>
General Ed. Teacher	<i>Shila Cramer</i>
Level	HS LS
Special Ed. CM	<b>Dana Kwiecinski</b>
General Ed. Teacher	<i>Brigitt Watts</i>

HS Learning Support	
Level	HS LS
Special Ed. CM	<b>Theresa Draeger</b>
General Ed. Teacher	<i>Jason Donley</i>
Level	HS LS
Special Ed. CM	<b>Sam Bonniger</b>
General Ed. Teacher	<i>Cara Schweizer</i>
Level	HS LS
Special Ed. CM	<b>Lynn Pagliei</b>
General Ed. Teacher	<i>Jaclyn Scherrbaum</i>
Level	HS LS
Special Ed. CM	<b>Sasha Young</b>
General Ed. Teacher	<i>Diane Broniszeewski</i>



# HS Emotional Support

HS Emotional Support	
Level	HS ES
Special Ed. CM	<b>Melissa Stump</b>
General Ed. Teacher	Nicole Camaioni
Level	HS ES
Special Ed. CM	<b>Amy Raught</b>
General Ed. Teacher	Anita Deloe
Level	HS ES
Special Ed. CM	<b>Serena Adams</b>
General Ed. Teacher	Barbara Thayer



# HS Autistic Support & Special Services

HS Special Services	
Level	HS SS
Special Ed. CM	<b>Erin Scrip</b>
General Ed. Teacher	Morgan Galonski
Level	HS SS
Special Ed. CM	<b>Amber Staley</b>
General Ed. Teacher	Jennifer Martin
HS Autistic Support	
Level	HS SS
Special Ed. CM	<b>Shari Widlund</b>
General Ed. Teacher	Angela Hetrick



# K-12 Speech and Language Support

K-12 Speech	
Level	Speech
Special Ed. CM	<b>Melanie Stanforth</b>
General Ed. K5	Melody Boisvert
General Ed. MS	Arlene Sheffo
General Ed. HS	Lory Soda



# Additional Teachers

<b>Additional General Ed. Teachers</b>
(ES) Autumn Whitebread
(ES) Angela Majzlik
(MS) Kenneth Sarber
(MS) Keri Abel
(HS) Diane Kunitsky
(HS) John Riggs

<b>Additional Special Ed. (SUBS)</b>
Christine Thomas (HS)
Laura Stapf (HS)
Emily Forrest (K-8)



# Summer LEA's

Elementary School	Middle School	High School	
James Montgomery	Alina Kitchell	Colleen Freyvogel	Jeff Miller
Jansen Hornbake	Bridget Kozar	Danielle Schall	Laura Goldman
Katy Giovanisci	Eric Buffington	Erin Hilson	Michelle Olsavsky
Kristie Hawk	Fallon Nicholas	Erinn Slackfish	Morgan Witman
Michelle Cukauskas	Heather Bianconi	Gina Szczepkowski	Pam Keth
Jen Fisher	Jen Lucia	Heather McCormick	Paul Harkins
Candace Kreutzer	Susan Detwiler	Holly Allen	Valerie Natale
Denise Curry	Maryann Johnson	Caleb Cragle	Melissa Jusko
Jamie Grant	Amanda Harbaugh	Jesse Capitano	Mike Schierer
Katie Wright	Angela Bayly	Julie Mcrea	Rebecca Adams
Lauren Shaffer	Briene Ryan	Katie DiStefano	Steve Nugent
Lauren Wilson	Colleen Richardson	Kim Fiscus	Tara Quisito
Laurie Super	John Thomas	Crystal Long	Tonya Smith
Mike Floyd	Liz McEwen	Jaclyn O'Reilly	Whitney Bargerstock
Robin Hartman	Melissa Patterson	Marie Williams	
Anna Lepsch			



# Are you taking summer vacation?

## Special Education Teachers only:

Please add your vacation information to this sheet so Danielle & Michelle do not assign you

IEPs during your time off.

<https://docs.google.com/spreadsheets/d/1NWT508YiLTifD6rwws4oXXqBr6EC8AKcGvSQv9Ofgww/edit?usp=sharing>



# Procedure



- Michelle Cukauskas will assign the IEP's to the HS team
- Danielle Schall will assign IEPs to the HS team
- Special Education teacher /IEP Writer will receive an email with assignment from Michelle or Danielle. Assignments will begin on Monday, 6/13.
- Initial Assignments may be a result of ER/RR's that were sent in the last few weeks of school – These IEP's may have a draft started, completed and/or have an attempt completed. Initial assignments will have a shortened timeline for completion. Specific information will be included in the e-mail.
- Remaining summer assignments may be resulting from an ER/RR. You must adhere to usual timelines & follow IEP procedures.
- Summer IEP Teams should establish days/times that work best

# Special Education Responsibilities

- Baseline the student based upon NEW needs in the reports.
  - Unless new need area – Use old goal (\*no new baseline needed)
  - Newly Identified (ER) or new need (RR) – Must be baselined.
- Reach out to your general ed. teacher and family to schedule the meeting.
- Sign up for an LEA (sign-up sheet on following slides)
- Send an outlook calendar invite to the IEP team.
- Create the Invite, IEP, and NOREP for the meeting.

# Special Education Responsibilities cont.

- Update and revise the draft after the meeting, per LEA recommendations on the IEP analysis and team discussion.
- Send the documents via docs to file. Ensure the IEP is finalized in Tyler.
- Ensure all required team members and related service providers attend the meeting if applicable.
- Complete the smartsheet indicating that the meeting has been held and NOREP has been signed
  - Anne Dieter will share the smartsheet with you.
- ❖ The IEP meeting procedure can be found in the Special Education Shared Folder All School, under “Policies & Procedures”.
- ❖ The Doc 2 File Links for K-6; 7-9; 10-12 can be found on the

# High School Scheduling for 21/22 SY

## Newly ID'd and Newly Enrolled (cells will not be locked)

- Shelley will be adding newly enrolled and newly ID'd students to the HS scheduling sheet. As you hold IEP meetings, please update the HS course scheduling sheet and e-mail the School Counselor with the student's special education course recommendations and cc Danielle.
- Students that are newly ID'd cannot have courses added to their schedules until we have a signed, approved NOREP that the office has reviewed but you can still note your recommendations. Once the office notifies you that the signed, approved NOREP has been received, the counselor will then schedule the SE courses in Tyler since you no longer have access.

## Changes for Current Students (cells will be locked)

- If you have any SE course changes to make for 22/23 SY due to an IEP team decision this summer for current students, please discuss with your supervisor. Your supervisor will make the updates to the sheet as those student cells will be locked. Any changes to a cell will have then be marked in

# General Education Teacher Responsibilities

- Collaborate with your special education teacher on scheduling.
- Provide thoughtful input and help to answer questions during the IEP meeting.
- Share your knowledge of the general education curriculum as questions arise.
- Share your knowledge of what SDI CAN be implemented. If you notice something written that truly will not work in the general education

# LEA Responsibilities

- Sign up for at least 2 time slots per week on the LEA sign-up sheet. This should be done **at least 3 weeks** in advance for each week.
  - **By 6/10, Please sign up for 2 time slots each week for (at least) the next 3 weeks.**
  - *Some LEA's are June & August only.*
- Provide thoughtful input and help to answer questions during the IEP meeting.
- Help to support the special education teacher based upon the analysis form during the meeting.
- Complete the IEP analysis and upload the analysis to the





# Tracking Time Worked - IEP Teams

- IEP writer will receive up to 5 hours of prep to prepare the IEP and hold the IEP meeting
- If you need more time than 5 hours please request approval from Michelle (K8) or Danielle (HS) in advance with justification.
- IEP team should log on their timesheet the time spent in the IEP meeting.
- If the parent doesn't show the team can log 15 minutes for the attempt.
- The team must attempt to contact the parent at the scheduled time to count as an attempt.

# Timesheets

- A timesheet and timesheet schedule will be provided to you.
- Timesheets should be submitted via email by COS, last day of the pay period.
- Timesheets should be in EXCEL.
- We are not able to follow up with you if you did not submit your timesheet on time. You will be paid the next pay period if that occurs.
- Timesheets are paid in arrears @ \$30 per hour.
- Most of the cells now have drop down selections available for dates, type of work etc.
- E-mail your completed timesheet to Erinn Slacktish.
  - If you also teach ESY, send ONE timesheet to the Director of the position you have the most hours (*Jen Fisher - ESY: Erinn Slacktish - TEP*)

# Summer Agora Tech Help



- Summer Hours of operation
  - 6/13/2022 - 8/22/2022
  - Monday-Friday, 7:30 am - 2:30 pm
- For issues with: ClassLink, Tyler, and Special Education AT Equipment
  - Web\*: <https://support.agora.org>
  - Email\*: [support@agora.org](mailto:support@agora.org)
  - Phone: 844-507-8233
- The Agora Support Corner
  - <https://www.help.k12.com/s/article/The-Agora-Support-Corner>

# What do I do over the summer when a student is possibly in Crisis? (1)

Keep the student in class with you and/or on the phone to ensure her/his safety while contact a summer administrator.

Administrator should follow ALGEE protocols to determine the level of crisis response needed.

1. **A**ssess for risk of suicide or self-harm
2. **L**isten non-judgmentally
3. **G**ive supports and information
4. **E**ncourage appropriate professional help
5. **E**ncourage other supports



While the administrator is engaging the student, the teacher should be attempting to get an adult attached to the child and ensure the child is physically safe, seen, and not in need of medical care. See if student has a mental health provider or direct line to a therapist or crisis facility to contact. Make contact as needed.

# What do I do over the summer when a student is possibly in Crisis? (2)

If you are unable to reach an adult or unable to verify safety, call 911 and request a well check.

Make sure to let 911 know of the county the student is in because they may need to connect you to the correct county dispatcher.

- If 911 is unable to connect you, you may have to google the local police phone number.
- If the local police number is not available (not all communities have 24-hour police), call the closest state trooper barracks.
- The police will need the address and phone number of the current location of the student – it may not be the one in Tyler or TV. The kid could be at a relative's house or something. Information on the current status of the situation. A call back number for the administrator. Sometimes they ask if we are aware of any weapons on premise or danger.
- Ask for office/dispatcher name and request for a phone number and a call back after they go to the home.
- Inform the child – not until you know help is coming- that help is coming. She/he may be upset or afraid. Please reassure that no one is in trouble. It is only to help them. Stay on the phone until the police arrive. Sometimes the officers will talk with you on scene, sometimes they call back, sometimes they don't.
- Follow up the next day with the parents.
- **Note all interactions made in Tyler.**

# School Counselor Summer Coverage



## July 1, 6-8\*

Roxanne Zeisloft

Laura Manko

## July 11-15

Barron Whited

Laura Manko

## July 18-22

Erica Lee

Danielle Ambrose

## July 25-29

Danielle Ambrose



# Questions?

*Thank you for  
supporting our  
Summer IEP Teams  
this year!*

***HAVE A GREAT  
SUMMER!***

Attendees Live

Danielle Schall  
Michelle Cukauskas  
Michael Scheirer  
Caleb Cragle  
Marie Williams  
Paul Harkins  
Melissa Jusko  
Katie Wright  
Amber Spindler  
Susan Detwiler  
Jeffrey Miller  
Jason Donley  
Robin Hartman  
Jennifer Clark  
Whitney Bargerstock  
Beth Stevens  
Holly Allen  
Brigitt Watts  
Cara Schweizer  
Angela Majzlik  
Jaclyn O'Reilly  
Eric Buffington  
Shila Cramer  
Pamela Keth  
Barbara Thayer  
Angela Bayly  
Melanie Stanforth  
Brianna Ryen  
Anna Lepsch  
Brittany Brown  
Michelle Pelissier  
Lory Soda  
Erin Scrip  
Elizabeth McEwen  
Jansen Hornbake  
Serena Adams  
Allyson Morris  
Diane Kunitzky  
Gina Sczepkowski  
Kenneth Sarber  
Jamie Grant  
Autumn Whitebread  
Alina Kitchell  
Morgan Galonski  
Crystal Long  
Jennifer Martin

Maryann Johnson  
John Riggs  
Michael Floyd  
Jaclyn Scherrbaum  
James Montgomery  
Cara Schweizer  
Anita Deloe  
Lynn Pagliei  
Brianna Ryen  
Laurie Super  
Heather Bianconi  
Diane Broniszewski  
Nicole Camaioni  
Samantha Bonniger  
Chris Baker  
Carmen Riggle  
Tammy Saad  
Theresa Draeger  
Laura Stapf  
Angela Hetrick  
Shila Cramer  
Susan Lipiec  
Dana Kwiecinski  
Melissa Jusko  
Morgan Witman  
Melissa Stump  
Shari Widlund  
Stefanie Marcello  
Amy Raught  
Melissa Love  
Brianna Pontious  
Theresa Bash  
Christine Thomas  
Candace Kreutzer  
Emily Forrest  
Sasha Young  
Jen Lucia  
Kimberly Fiscus  
Susan Lelko  
Sarah Rau  
Stacy Vietmeier  
Keri Abel  
Kristina Lapsker  
Shelley Stump  
Valerie Natale



# Agenda

- ▶ Why should you know how to utilize Easy Trac?
- ▶ What information should you have handy before logging in?
- ▶ How do you log into Easy Trac
- ▶ How do you access a student?
- ▶ Select the correct student
- ▶ How do I find information-Option A
- ▶ How do I find information-Option B
- ▶ WAIT! What if I see more than one therapist?
- ▶ Related services tab
- ▶ How do I run a service report for a related service?
- ▶ Service Report Sample
- ▶ Running Service Documentation Review Report
- ▶ Documenting contact in EasyTrac
- ▶ Communication with Therapist
- ▶ Sample introduction email
- ▶ Monthly email
- ▶ Thank you!!

<b>Timestamp</b>	<b>Email Address</b>	<b>First Name</b>
8/10/2021 12:41:39	bstevens2@agora.org	Brett
8/10/2021 13:25:00	jshaffer3@agora.org	Janelle
8/11/2021 12:09:17	tkozak@agora.org	Tamara
8/11/2021 13:30:24	klapsker@agora.org	Kristina
8/11/2021 13:33:11	svietmeier@agora.org	Stacy
8/11/2021 14:32:10	matwood@agora.org	Maree
8/11/2021 15:40:36	asweeney@agora.org	Allison
8/11/2021 23:18:04	bcantwell@agora.org	Brittney
8/12/2021 10:52:15	mlove@agora.org	Melissa
8/12/2021 16:28:26	lbrestensky@agora.org	Lisa
8/12/2021 16:54:27	nreimers@agora.org	Nancy
8/13/2021 10:03:32	hsilberman@agora.org	Heather
8/13/2021 11:42:53	jbuss@agora.org	Jennifer
8/13/2021 12:46:01	cbyers@agora.org	Colien
8/13/2021 15:17:44	rperri@agora.org	Renee
8/13/2021 16:09:09	jdepietro@agora.org	Jennifer
8/13/2021 20:55:21	dpacolay@agora.org	Dana
8/14/2021 21:00:04	slelko@agora.org	Susan
8/14/2021 23:33:14	akimmage@agora.org	Amanda
8/14/2021 23:36:05	akimmage@agora.org	Amanda
8/15/2021 17:08:50	alarge@agora.org	Allison
8/16/2021 0:00:14	akammermeier@agora.org	Amanda
8/16/2021 7:41:06	jhuffman@agora.org	Jena
8/16/2021 10:07:08	lstapf@agora.org	Laura
8/16/2021 10:07:23	sbonniger@agora.org	Samantha
8/16/2021 13:10:32	abrisbane@agora.org	Amber
8/16/2021 15:11:18	rcarmichael@agora.org	Rachel
8/16/2021 16:20:27	mstump@agora.org	Melissa
8/16/2021 16:36:23	criggle@agora.org	Carmen
8/16/2021 16:38:21	jbuckwalter@agora.org	JoDeen
8/17/2021 8:34:25	jdeemer@agora.org	Judith

<b>Timestamp</b>	<b>Email Address</b>	<b>First Name</b>
8/17/2021 9:49:26	molsavsky@agora.org	Michelle
8/17/2021 10:22:34	aarmstrong@agora.org	Amanda
8/17/2021 10:37:49	nkrol@agora.org	Nicole
8/17/2021 11:08:31	cmack@agora.org	Cathryn
8/17/2021 11:59:25	cbarkley@agora.org	Cortney
8/17/2021 12:04:49	cbarkley@agora.org	Cortney
8/17/2021 12:09:28	twalker@agora.org	Tara
8/17/2021 14:32:09	astaley2@agora.org	Amber
8/17/2021 21:29:27	jmoyer2@agora.org	Jill
8/17/2021 21:31:29	asalimbene@agora.org	Ashley
8/18/2021 0:06:29	kodonnell@agora.org	Katie
8/18/2021 8:21:57	tdraeger@agora.org	Theresa
8/18/2021 10:23:15	jflatley@agora.org	Jennifer
8/18/2021 11:59:35	cpanchura@agora.org	Chelsey
8/18/2021 12:01:16	cemrick@agora.org	Carissa
8/18/2021 13:43:54	bpontious@agora.org	Brianna
8/18/2021 13:55:32	dodonnell@agora.org	Dana
8/18/2021 13:58:33	dodonnell@agora.org	Dana
8/18/2021 14:02:16	jbeeken@agora.org	Jennifer
8/18/2021 15:23:10	mgaso@agora.org	Melissa
8/18/2021 18:03:07	skennedy@agora.org	Sabrina
8/18/2021 18:08:31	skennedy@agora.org	Sabrina
8/19/2021 7:53:35	mfranklin@agora.org	Melissa
8/19/2021 8:27:17	cwiddop@agora.org	Christen
8/19/2021 11:22:23	bcooper@agora.org	Barb
8/19/2021 13:50:04	tambuka@agora.org	Tracey
8/19/2021 13:54:06	tambuka@agora.org	Tracey
8/19/2021 14:08:38	gkaufman@agora.org	Gillian
8/19/2021 14:09:56	jbarnhart@agora.org	Jessica
8/19/2021 14:14:18	aschmidt@agora.org	Ashley

<b>Timestamp</b>	<b>Email Address</b>	<b>First Name</b>
8/19/2021 14:15:03	afarster@agora.org	Ashley
8/19/2021 14:54:30	adenham@agora.org	Angela
8/19/2021 15:28:35	gmattox@agora.org	Gemma
8/19/2021 16:04:26	lsvonavec@agora.org	Lauren
8/19/2021 23:00:42	gdonch@agora.org	Gina
8/20/2021 7:34:08	khumanick@agora.org	Kymberly
8/20/2021 9:33:01	eslacktish@agora.org	Erinn
8/20/2021 9:49:03	llamison@agora.org	Lauren
8/20/2021 11:38:46	gmallon@agora.org	Gina
8/20/2021 12:02:12	sadams@agora.org	Serena
8/20/2021 12:10:11	sadams@agora.org	Serena
8/20/2021 12:42:03	mpatterson@agora.org	Melissa
8/20/2021 14:08:48	araught@agora.org	Amy
8/20/2021 15:21:12	lspratt@agora.org	Leslie
8/20/2021 15:29:10	lspratt@agora.org	Leslie
8/20/2021 15:58:29	jscadieux@agora.org	Jennifer
8/20/2021 17:13:32	kshannon@agora.org	Keri
8/20/2021 18:55:27	mbasso@agora.org	Maura Basso
8/20/2021 22:55:02	lkerns@agora.org	Lauren
8/21/2021 20:24:52	mgarczynski@agora.org	Molly
8/21/2021 23:26:39	rcongdon@agora.org	Rebekah
8/22/2021 11:24:32	escrip@agora.org	Erin
8/22/2021 11:51:22	slipiec@agora.org	Susan
8/22/2021 15:27:21	kwelsh@agora.org	Kristy
8/22/2021 16:07:39	lradico@agora.org	Lauren
8/22/2021 20:04:08	kplatt@agora.org	Keith
8/22/2021 22:33:21	bfroehlich@agora.org	Brittany
8/23/2021 0:41:04	cbaker@agora.org	Chris
8/23/2021 7:48:58	jzollman@agora.org	Jennifer
8/23/2021 8:28:14	vjackson@agora.org	Veronica

<b>Timestamp</b>	<b>Email Address</b>	<b>First Name</b>
8/23/2021 9:30:52	kamodeo@agora.org	Kattreena
8/23/2021 13:01:05	lsavitz@agora.org	Lisa
8/23/2021 13:27:45	abaranoski@agora.org	Anna
8/23/2021 14:21:12	kcostanzo@agora.org	Kristal
8/23/2021 14:22:44	cthomas@agora.org	Christi
8/24/2021 11:19:44	bellis@agora.org	Bridget
8/24/2021 11:23:10	bellis@agora.org	Bridget
8/24/2021 14:17:59	syoung@agora.org	Sasha
8/26/2021 8:58:43	dfurka@agora.org	David
8/26/2021 9:01:27	dfurka@agora.org	David
8/26/2021 11:23:06	kpaolino@agora.org	Kimberly
8/26/2021 11:24:32	breamer@agora.org	Brittany
8/26/2021 11:48:10	jlinderman@agora.org	Jessica
8/26/2021 17:45:34	jdoebereiner@agora.org	Julie
8/27/2021 15:34:24	khoffman@agora.org	Kaelyn
8/29/2021 22:53:54	jreese@agora.org	Jessica
8/30/2021 12:03:58	tbash@agora.org	Theresa
8/30/2021 12:09:52	tbash@agora.org	Theresa
8/30/2021 12:13:00	tbash@agora.org	Theresa
9/1/2021 12:21:18	mmccracken@agora.org	Melissa
9/1/2021 12:23:15	rkubica@agora.org	Regina
9/1/2021 12:39:03	shoffmaster@agora.org	Shannon
9/1/2021 15:52:54	smarcello@agora.org	Stefanie

# Meeting Agenda

## Updates and Reminders

- Who's Who
- Expectations (team / professionalism)
- Communication Protocols
- Tyler Documentation
- Grading Policies
- Catch-Up Days
- Common Planning Block
- PTO
- Differentiated Supervision
- Advisory Welcome Calls
- Odds and Ends
- Student Assembly Info
- Good of the Group



**Freyvogel Team Training Attendance 8/23/21**

Allison Large

Amanda Armstrong

Amber Staley

Brett Stevens

Carissa Emrick

Chelsey Panchura

Colien Byers

Colleen Freyvogel Bruss

Dana Pacolay

Erin Scrip

Janelle Shaffer

Jennifer Beeken

Jennifer Cadiuex

Kimberly Fiscus

Kristy Welsh

Lauren Radico

Lisa Brestensky

Melissa McCracken

Nicole Krol

Regina Kubica

Renee Perri

Shannon Hoffmaster

Tracey Ambuka

Whitney Bargerstock



Model Memorandum of Understanding

---

**Memorandum of Understanding  
Between**

Upper Merion Township Police Department

---

(Law Enforcement Authority)

and

Agora Cyber Charter School

---

(School Entity)

August 2, 2022

---

(Date)

**I. Introduction**

**A. Parties**

The following Law Enforcement Authority or Authorities agree to follow the policies and procedures contained in this Memorandum of Understanding (hereinafter – Memorandum):

Upper Merion Township Police Department  
175 W. Valley Forge Road  
King of Prussia, PA 19406

The following School Entity or Entities agree to follow the policies and procedures contained in this Memorandum:

Agora Cyber Charter School  
1018 W. 8th Avenue  
King of Prussia, PA 19406

- B. This Memorandum establishes procedures to be followed when certain incidents – described in Section II below – occur on school property, at any sponsored activity, or on a conveyance as described in the Safe Schools Act (such as a school bus) providing transportation to or from a school or school sponsored activity. This Memorandum does not cover incidents that are outside of those school settings and create no substantial disruption to the learning environment.



C. The parties seek to foster a relationship of cooperation and mutual support and to maintain a safe school environment.

D. Legal Authority

1. The parties make this agreement as required by Article XIII-A of the Public School Code of 1949, popularly known as the – Safe Schools Act, as amended, 24 P.S. §§ 13-1301-A – 13-1313-A.

2. In so recognizing this legal authority, the parties acknowledge their respective duties pursuant to the Safe Schools Act and hereby agree to support and cooperate with one another in carrying out their joint and several responsibilities thereunder.

3. Information from Student Records

a. The Law Enforcement Authority shall be governed by the following reporting and information exchange guidelines:

i. Criminal History Record Information Act, 18 Pa C.S. § 1901 *et seq.*

ii. The prohibition against disclosures, specified in section IV (C)(5) of this Memorandum.

b. When sharing information and evidence necessary for the Law Enforcement Authority to complete its investigation, the School Entity shall:

i. Comply with the Family Educational Rights and Privacy Act (hereinafter -FERPA), 20 U.S.C. § 1232g, and its implementing regulations at 34 C.F.R. § 99.1 *et seq.*, and 22 Pa. Code §§ 12.31-12.33, including any amendments thereto.

ii. Comply with the requirements of the Safe Schools Act, 24 P.S. §§ 13-1303-A and 13-1313-A, and any amendments thereto.

iii. Complete reports as required by section 13-303-A of the Safe Schools Act, 24 P.S. § 13-1303-A, and any amendments thereto.

c. The School Entity may disclose personally identifiable information from an educational record of a student to the Law Enforcement Authority if a health or safety emergency exists and knowledge of that information is necessary to protect the health or safety of the student or other individuals. In determining whether a health or safety emergency exists, the School Entity may take into account the totality of the circumstances pertaining to a threat to the health or safety of a student or other individuals. If the School Entity determines that there is an articulable and significant threat to the health or safety of a student or other individuals, it may disclose information from education records to the Law Enforcement Authority, if knowledge of that information is necessary for the Law Enforcement Authority to protect the health or safety of the student or other individuals. The School Entity must record the articulable and significant threat to the health or safety of a student or other

individuals so that it can demonstrate to parents, students and the Family Policy Compliance Office<sup>1</sup> – what circumstance led it to determine that a health or safety emergency existed and why the disclosure was justified.

E. Priorities of the Law Enforcement Authority

1. Help the School Entity prevent delinquent acts through preventive measures, including referrals to support services, diversionary programs, restorative practices, school-wide positive behavior supports, education and deterrence.
2. Investigate as appropriate all incidents reported to have occurred on school property, at any school sponsored activity, or on a conveyance as described in the Safe Schools Act (including a school bus) providing transportation to or from a school or school sponsored activity. The investigation of all reported incidents shall be conducted in the manner that the Law Enforcement Authority, in its sole discretion, deems appropriate; but any investigation shall be conducted so as to involve as little disruption to the school environment as is practicable.
3. Identify those responsible for the commission of the reported incident and, where appropriate, apprehend and prosecute those individuals. Identification and apprehension procedures shall involve as little disruption to the school environment as is practicable.
4. Establish and maintain a cooperative relationship with the School Entity in the reporting and resolution of all incidents described in Section II of this document.

F. Priorities of the School Entity

1. Help law enforcement prevent delinquent acts through preventive measures, including referrals to support services, diversionary programs, restorative practices, school-wide positive behavior supports, education and deterrence.
2. Create a safe learning environment.
3. Establish and maintain a cooperative relationship with the Law Enforcement Authority in the reporting and resolution of all incidents described in Section II of this document.
4. Provide the Law Enforcement Authority with all relevant information and required assistance in the event of a reported incident.
5. The School Entity shall give the Law Enforcement Authority a copy of the School Entity's behavior support services procedures and invite Law Enforcement Authority representatives to behavior support trainings.

---

<sup>1</sup>Questions related to FERPA should be directed to the Family Policy Compliance Office within the U.S. Department of Education.

## II. Notification of Incidents to Law Enforcement

The School Entity is required to notify law enforcement in specific situations listed in subsection A of this section, and has discretion over whether to notify law enforcement about incidents listed in subsection B of this section. Law enforcement's decision to investigate and file charged may be made in consultation with school administrators.

### A. Mandatory Notification

1. The School Entity shall immediately notify the Law Enforcement Authority having jurisdiction where the offense occurred by the most expeditious means practicable of any of the following incidents occurring on school property, at any school sponsored activity, or on a conveyance as described in the Safe Schools Act (including a school bus) providing transportation to or from a school or school sponsored activity:

a. The following offenses under 18 Pa.C.S. (relating to crimes and offenses):

i. Section 908 (relating to prohibited offensive weapons).

a. The term offensive weapon is defined by section 908 of the Crimes Code as any bomb, grenade, machine gun, sawed-off shotgun with a barrel less than 18 inches, firearm specially made or specially adapted for concealment or silent discharge, any blackjack, sandbag, metal knuckles, dagger, knife, razor or cutting instrument, the blade of which is exposed in an automatic way by switch, push-button, spring mechanism, or otherwise, any stun gun, stun baton, taser or other electronic or electric weapon or other implement for the infliction of serious bodily injury which serves no common lawful purpose. See 18 Pa.C.S. § 908 (c) (relating to definitions).

b. Consistent with section 908(b) of the Crimes Code (relating to exceptions), this reporting requirement does not apply to one who possessed or dealt with an offensive weapon solely as a curio or in a dramatic performance, or to one who possessed an offensive weapon briefly in consequence of having found it taken it from an aggressor, or under circumstances similarly negating any intent or likelihood that the weapon would be used unlawfully.

ii. Section 912 (relating to possession of weapon on school property).

a. The term weapon is defined by section 912 of the Crimes Code to include but is not limited to, a knife, cutting instrument, cutting tool, nunchuck stick, firearm, shotgun, rifle and any other tool, instrument or implement capable of inflicting serious bodily injury.

b. Consistent with section 912(c) of the Crimes Code (relating to defense), this reporting requirement does not apply to a weapon that is: (a) possessed and used in conjunction with a lawful supervised school activity or course; or (b) is possessed for other lawful purpose.

- iii. Chapter 25 (relating to criminal homicide).
  - iv. Section 2702 (relating to aggravated assault).
  - v. Section 2709.1 (relating to stalking).
  - vi. Section 2901 (relating to kidnapping).
  - vii. Section 2902 (relating to unlawful restraint).
  - viii. Section 3121 (relating to rape).
  - ix. Section 3122.1 (relating to statutory sexual assault).
  - x. Section 3123 (relating to involuntary deviate sexual intercourse).
  - xi. Section 3124.1 (relating to sexual assault).
  - xii. Section 3124.2 (relating to institutional sexual assault).
  - xiii. Section 3125 (relating to aggravated indecent assault).
  - xiv. Section 3126 (relating to indecent assault).
  - xv. Section 3301 (relating to arson and related offenses)
  - xvi. Section 3307 (relating to institutional vandalism), when the penalty is a felony of the third degree.
  - xvii. Section 3502 (relating to burglary).
  - xviii. Section 3503(a) and (b)(1)(v)(relating to criminal trespass).
  - xix. Section 5501 (relating to riot).
  - xx. Section 6110.1 (relating to possession of firearm by minor).
- b. The possession, use or sale of a controlled substance, designer drug or drug paraphernalia as defined in The Controlled Substance, Drug, Device and Cosmetic Act, *as amended*, 35 P.S. §§ 780-101 – 780-144, popularly known as the Drug Act. For purposes of the Memorandum, the terms controlled substance, designer drug and drug paraphernalia shall be defined as they are in Section 102 of the Drug Act. See 35 P.S. § 780-102 (relating to definitions).
  - c. Attempt, solicitation or conspiracy to commit any of the offenses listed in paragraphs 1 and 2 of this subsection.
  - d. An offense for which registration is required under 42 Pa.C.S. § 9795.1 (relating to registration).

2. In responding to student who commit an incident listed under section 1303-A(b)(4.1) of the Safe Schools Act (24 P.S. § 13-1303-A(b)(4.1)), a school entity may consider the propriety of utilizing available school-based program, such as school-wide positive behavior supports, to address the student's behavior. Nothing in this provision shall be read to limit law enforcement's discretion.

B. Discretionary Notification

1. The School Entity may notify the Law Enforcement Authority having jurisdiction where the incident occurred of any of the following incidents occurring on school property, at any school sponsored activity, or on a conveyance as described in the Safe Schools Act (including a school bus) providing transportation to or from a school or school sponsored activity:
  - a. The following offenses under 18 Pa.C.S. (relating to crimes and offenses):
    - i. Section 2701 (relating to simple assault)
    - ii. Section 2705 (relating to recklessly endangering another person).
    - iii. Section 2706 (relating to terroristic threats).
    - iv. Section 2709 (relating to harassment).
    - v. Section 3127 (relating to indecent exposure)
    - vi. Section 3307 (relating to institutional vandalism), when the penalty is a misdemeanor of the second degree.
    - vii. Section 3503(b)(1)(i), (ii), (iii), and (iv), (b.1) and (b.2) (relating to criminal trespass).
    - viii. Chapter 39 (relating to theft and related offenses).
    - ix. Section 5502 (relating to failure of disorderly persons to disperse upon official order).
    - x. Section 5503 (relating to disorderly conduct).
    - xi. Section 6305 (relating to sale of tobacco).
    - xii. Section 6306.1 (relating to use of tobacco in schools prohibited).
    - xiii. Section 6308 (relating to purchase, consumption, possession, or transportation of liquor or malt or brewed beverages by a person under 21 years of age).
  - b. Attempt, solicitation or conspiracy to commit any of the offenses listed in subsection (a).
2. In exercising its discretion to determine whether to notify law enforcement of such incidents, the School Entity may consider the following factors: the seriousness of the situation, the school's ability to defuse or resolve the situation, the child's intent, the child's

age, whether the student has a disability and, if so, the type of disability and its impact on the student's behavior, and other factors believed to be relevant.

C. Law Enforcement Response to Notification

1. When notified of an incident listed in subsections A or B, law enforcement's decision to investigate and file charges, at the sole discretion of the Law Enforcement Authority, may be made in consultation with school administrators.
2. In determining whether to file charges, the Law Enforcement Authority is encouraged to consult with the District Attorney. Where appropriate under the law, part of this consultation may include a discussion about the availability or propriety of utilizing a diversionary program as an alternative to filing charges.

D. Notification of the Law Enforcement Authority when incident involves children with disabilities

1. If a child with a disability commits an incident of misconduct, school administrators and the Law Enforcement Authority should take into consideration that the child's behavior may be a manifestation of the disability and there may be no intent to commit an unlawful act. A child with a disability under this subsection shall mean a student with an IEP, a protected handicapped student with a service agreement that includes a behavior support plan, or such student for whom an evaluation is pending under 22 Pa. Code §§ 14.123 (relating to evaluation), 15.5 (relating to school district-initiated evaluation and provision of services), 15.6 (relating to parent-initiated evaluation and provision of services), or Chapter 711 (relating to charter school and cyber charter school services and programs for children with disabilities).
2. In the event a child with a disability commits a mandatory notification offense under Subsection A, the School Entity must provide immediate notification to the Law Enforcement Authority regardless of the disability. Such notification will state that the child has an IEP or a service agreement that includes a behavior support plan and may include the School Entity's recommendation that police intervention may not be required and advisement that the School Entity will address the student's behavior need as required by applicable federal and state law and regulations, including 22 Pa. Code §§ 14.133 (relating to positive behavior support), 15.3 (relating to protected handicapped students general) or 711.46 (relating to positive behavior support). The Law Enforcement Authority may take the recommendation under advisement but reserves the right to investigate and file charges.
3. In the event a child with a disability commits a discretionary offense under Subsection B and the School Entity does not believe that police intervention is necessary, the School Entity will address the student's behavior need as required by applicable federal and state law and regulations, including 22 Pa. Code §§ 14.133, 15.3 or 711.46.
4. In accordance with 34 CFR 300.535 (relating to referral to and action by law enforcement and judicial authorities), nothing will prohibit the School Entity from reporting an offense committed by a child with a disability to the Law Enforcement Authority, and nothing will prevent State law enforcement and judicial authorities from exercising their responsibilities with regard to the application of Federal and State law to crimes committed by a child with a disability.

5. The School Entity, when reporting an offense committed by a child with a disability, should ensure that copies of the special education and disciplinary records of the child are transmitted for consideration by the appropriate authorities to the Law Enforcement Authority to whom the incident was reported.
  6. The School Entity, when reporting an incident under this section, may transmit copies of the child's special education and disciplinary records only to the extent that the transmission is permitted by FERPA.
- E. Upon notification of the incident to the Law Enforcement Authority, the School Entity shall provide as much of the following information as is available at the time of notification. In no event shall the gathering of information unnecessarily delay notification:
1. Whether the incident is in-progress or has concluded.
  2. Nature of the incident.
  3. Exact location of the incident.
  4. Number of persons involved in the incident.
  5. Names and ages of the individuals involved.
  6. Weapons, if any, involved in the incident.
  7. Whether the weapons, if any, have been secured and, if so, the custodian of the weapons.
  8. Injuries involved.
  9. Whether EMS or the Fire Department have been notified.
  10. Identity of the school contact person.
  11. Identity of the witnesses to the incident, if any.
  12. Whether the incident involves a student with a disability and, if so, the type of disability and its impact on the student's behavior.
  13. Other such information as is known to the school entity and believed to be relevant to the incident.
- F. No later than September 30 of each year, the School Entity shall assemble and make ready for immediate deployment to its Incident Command Post the following information for the purpose of assisting the Law Enforcement Authority in responding to an emergency:
1. Blueprints or floor plans of the school buildings.
  2. Aerial photo, map or layout of the school campus, adjacent properties and surrounding streets or roads.
  3. Location(s) of predetermined or prospective command posts.
  4. Current teacher/employee roster.
  5. Current student roster.
  6. Most recent school yearbook.
  7. School fire-alarm shutoff location and procedures.
  8. School sprinkler system shutoff location and procedures.
  9. Gas/utility line layouts and shutoff valve locations.
  10. Cable/satellite television shutoff location and procedures.
  11. Other information the School Entity deems pertinent to assist local police departments in responding to an emergency.

### III. Law Enforcement Authority Response

A. Depending on the totality of the circumstances, initial response by the Law Enforcement Authority may include:

1. For incidents in progress:

- a. Meet with contact person and locate scene of incident.
- b. Stabilize incident.
- c. Provide/arrange for emergency medical treatment, if necessary.
- d. Control the scene of the incident.
  - i. Secure any physical evidence at the scene.
  - ii. Identify involved persons and witnesses.
- e. Conduct investigation.
- f. Exchange information.
- g. Confer with school officials to determine the extent of law enforcement involvement required by the situation.

2. Incidents not in progress:

- a. Meet with contact person.
- b. Recover any physical evidence.
- c. Conduct investigation.
- d. Exchange information.
- e. Confer with school officials to determine the extent of law enforcement involvement required by the situation.

3. Incidents initially reported to the Law Enforcement Authority

If any incident described in sections IIA or IIB is initially reported to the Law Enforcement Authority, the Law Enforcement Authority shall proceed directly with its investigation, shall immediately notify the School Entity of the incident, and shall proceed as outlined in sections IIA through IIE.



## B. Custody of Actors

1. Students identified as actors in reported incidents may be taken into custody at the discretion of the investigating law enforcement officer under any of the following circumstances:
  - a. The student has been placed under arrest.
  - b. The student is being placed under investigative detention
  - c. The student is being taken into custody for the protection of the student.
  - d. The student's parent or guardian consents to the release of the student to law enforcement custody.
2. The investigating law enforcement officer shall take all appropriate steps to protect the legal and constitutional rights of those students being taken into custody.

## IV. Assistance of School Entities

### A. *In Loco Parentis*

1. Teachers, Guidance Counselors, Vice Principals and Principals in the public schools have the right to exercise the same authority as a parent, guardian or person in parental relation to such pupil concerning conduct and behavior over the pupils attending a school during the time they are in attendance, including the time required in going to and from their homes.
2. School authorities' ability to stand *in loco parentis* over children does not extend to matters beyond conduct and discipline during school, school activities, or on a conveyance as described in the Safe Schools Act providing transportation to or from school or a school sponsored activity.

### B. Notification of Parent or Guardian

1. Parents or guardians of all victims and suspects directly involved in an incident listed under Section IIA or IIB shall be immediately notified of the involvement, and they shall be informed about any notification regarding the incident that has been, or may be, made to the Law Enforcement Authority.
2. The School Entity shall document attempts made to reach the parents or guardians of all victims and suspects directly involved in incident listed under Section IIA or IIB.

### C. Scope of School Entity's Involvement

1. General principles: Once the Law Enforcement Authority assume primary responsibility for a matter, the legal conduct of interviews, interrogations, searches, seizures of property, and arrests are within the purview of the Law Enforcement Authority. The School Entity shall defer to the Law Enforcement Authority on matters of criminal and juvenile law procedure, except as is necessary to protect the interests of the School Entity. The Law Enforcement Authority will keep the chief school administrator, or his designees, informed of the status of pending investigations.

## 2. Victims

- a. The School Entity shall promptly notify the parent or guardian of a victim when the Law Enforcement Authority interviews that victim. The Law Enforcement Authority shall follow its policies and procedures when interviewing a victim to ensure the protection of the victim's legal and constitutional rights.
- b. In the event a victim is interviewed by Law Enforcement Authority on school property, a guidance counselor or similar designated personnel may be present during the interview.

## 3. Witness

- a. The School Entity shall promptly notify the parent or guardian of a witness when the Law Enforcement Authority interviews that witness. The Law Enforcement Authority shall follow its policies and procedures when interviewing a witness to ensure the protection of the witness's legal and constitutional rights.
- b. In the event a witness is interviewed by the Law Enforcement Authority on school property, a guidance counselor or similar designated personnel should be present during the interview.

## 4. Suspects and Custodial Interrogation

- a. The School Entity shall help the Law Enforcement Authority to secure the permission and presence of at least one parent or guardian of a student suspect before that student is interrogated by law enforcement authorities.
- b. When a parent or guardian is not present, school authorities shall not stand *in loco parentis* (in the place of the parent/guardian) during an interview.
- c. If an interested adult cannot be contacted, the School Entity shall defer to the investigating Law Enforcement Authority, which will protect the student suspect's legal and constitutional rights as required by law.

## 5. Conflicts of Interest

- a. The parties to this Memorandum recognize that if a School Entity employee, contractor, or agent of the School Entity is the subject of an investigation, a conflict of interest may exist between the School Entity and the adult suspect.
- b. Neither the individual that is the subject of the investigation, nor any person acting as his/her subordinate or direct supervisor, shall be present during Law Enforcement Authority's interviews of student co-suspects, victims or witnesses by the Law Enforcement Authority.
- c. Neither the individual who is the subject of the investigation, nor his/her subordinate(s) and/or direct supervisor(s), shall be informed of the contents of the statements made by

student co-suspects, victims or witnesses, except at the discretion of the Law Enforcement Authority or as otherwise required by law.

#### D. Reporting Requirements

All school entities are required to submit an annual report, which will include violence statistics and reports, to the Department of Education's Office for Safe Schools. This annual report must include all new incidents described in Sections IIA and IIB. Before submitting the required annual report, each chief school administrator and each police department having jurisdiction over school property of the School Entity shall do the following:

- a. No later than thirty days prior to the deadline for submitting the annual report, the chief school administrator shall submit the report to the police department with jurisdiction over the relevant school property. The police department shall review the report and compare the data regarding criminal offenses and notification of law enforcement to determine its accuracy.
- b. No later than fifteen days prior to the deadline for submitting the annual report, the police department shall notify the chief school administrator, in writing, whether the report accurately reflects police incident data. Where the police department determines that the report accurately reflects police incident data, the chief of police shall sign the report. Where the police department determines that the report does not accurately reflect police incident data, the police department shall notify the chief school administrator and the office in writing.
- c. Prior to submitting the annual report, the chief school administrator and the police department shall attempt to resolve discrepancies between the report and police incident data. Where a discrepancy remains unresolved, the police department shall notify the chief school administrator and the office in writing.
- d. Where a police department fails to take action as required under clause a or b, the chief school administrator shall submit the annual report and indicate that the police department failed to take action as required under clause a or b.
- e. Where there are discrepancies between the School Entity's incident data and the police incident data, the CEO of Agora and the chief of police will work to reconcile.

**V. General Provisions**

- A. This Memorandum does not create any contractual rights or obligations between the signatory Law Enforcement Authority, the signatory School Entity, any other signatory authorities or entities, or their respective officers, employees, agents or representatives.
- B. This Memorandum may be amended, expanded or modified at any time upon the written consent of the parties. It must be reviewed and re-executed within two years of the date of its original execution and every two years thereafter. Describe what modifications have been made to this Memorandum of Understanding. If you have not made any modifications or amended it in any way, please enter "Not Applicable" in the space provided.
- C. If changes in state or federal law require changes to the Memorandum, the parties shall amend this Memorandum.
- D. All parties to this Memorandum will communicate fully and openly with each other in order to resolve any problems that may arise in the fulfillment of the terms of this Memorandum.

  
\_\_\_\_\_  
Chief School Administrator

Agora Cyber Charter School  
\_\_\_\_\_  
School Entity

  
\_\_\_\_\_  
Chief Law Enforcement Authority

Upper Merion Township  
Police Department  
\_\_\_\_\_  
Law Enforcement Authority

  
\_\_\_\_\_  
Building Principal

Agora Cyber Charter School  
\_\_\_\_\_  
School Building

# Board Affirmation Statement

## LEA Name

Address 123 Street, City Town, PA 12345

The purpose of this document is for the President of the governing board to affirm that the annual report information is accurate.

### Steps to Complete this Section:

Note: Individual signatures required for each section.

1. Signature of President of the governing board and date signed for each section.
2. Upload Board Affirmation document which includes the Board President's signature and date signed.

## Charter Annual Report Affirmation

I verify that all information and records in this charter school annual report are complete and accurate.

Affirmed on this \_\_\_\_\_ day of \_\_\_\_\_, 20\_\_\_\_

By: \_\_\_\_\_ (Signature of Board President)

\_\_\_\_\_ (Print Name)

\_\_\_\_\_ Board of Trustees

## Charter School Law Affirmation

Pennsylvania's first Charter School Law was Act 22 of 1997, 24 P.S. § 17-1701-A et seq., which primarily became effective June 19, 1997, and has subsequently been amended.

The Charter School Law provides for the powers, requirements, and establishment of charter schools. The Charter School Law was passed to provide opportunities to teachers, parents, pupils and community members to establish and maintain schools that operate independently from the existing school district structure as a method to accomplish all of the following: (1) improve pupil learning; (2) increase learning opportunities for all pupils; (3) encourage the use of different and innovative teaching methods; (4) create new professional opportunities for teachers; (5) provide parents and pupils with expanded choices in types of educational opportunities that are available within the public school system; and (6) hold charter schools accountable for meeting measurable academic standards and provide the school with a method to establish accountability systems.

The charter school assures that it will comply with the requirements of the Charter School Law and any provision of law from which the charter school has not been exempted, including Federal laws and regulations governing children with disabilities. The charter school also assures that it will comply with the policies, regulations and procedures of the Pennsylvania Department of Education (Department).

Additional information about charter schools is available on the Pennsylvania Department's website at: <http://www.education.state.pa.us>.

Affirmed on this \_\_\_\_\_ day of \_\_\_\_\_, 20\_\_\_\_

By: \_\_\_\_\_ (Signature of Board President)

\_\_\_\_\_ (Print Name)

\_\_\_\_\_ Board of Trustees

## Ethics Act Affirmation

Pennsylvania's current Public Official and Employee Ethics Act (Ethics Act), Act 93 of 1998, Chapter 11, 65 Pa.C.S. § 1101 et seq., became effective December 14, 1998 and has subsequently been amended.

The Ethics Act provides that public office is a public trust and that any effort to realize personal financial gain through public office other than compensation provided by law is a violation of that trust. The Ethics Act was passed to strengthen the faith and confidence of the people of Pennsylvania in their government. The Pennsylvania State Ethics Commission (Commission) administers and enforces the provisions of the Ethics Acts and provides guidance regarding its requirements.

The regulations of the Commission set forth the procedures applicable to all proceedings before the Commission as well as for the administration of the Statement of Financial Interests filing requirements. See 51 Pa. Code § 11.1 et seq.

The charter school assures that it will comply with the requirements of the Ethics Act and with the policies, regulations and procedures of the Commission. Additional information about the Ethics Act is available on the Commission's website at: <http://www.ethics.state.pa.us>.

Affirmed on this \_\_\_\_\_ day of \_\_\_\_\_, 20\_\_\_\_

By: \_\_\_\_\_ (Signature of Board President)

\_\_\_\_\_ (Print Name)

\_\_\_\_\_ Board of Trustees

## Charter Annual Background Check Affirmation

I certify that, as of this date, the above referenced LEA is in compliance with all applicable provisions of Sections 111 and 111.1 of the Public School Code of 1949.

Affirmed on this \_\_\_\_\_ day of \_\_\_\_\_, 20\_\_\_\_

By: \_\_\_\_\_ (Signature of Board President)

\_\_\_\_\_ (Print Name)

\_\_\_\_\_ Board of Trustees

## Charter Annual Administrative Certification Affirmation

All public school principals, including charter and cyber charter school principals, are subject to the applicable certification requirements of the Public School Code ( 24 P.S. § 11-1109) as well as any Act 45 continuing education and Pennsylvania Inspired Leaders (PIL) requirements. In keeping with the intent of section 1109, any person who devotes half or more of their time to supervision or administration in a public school, without an identified principal, is serving as the “principal” of the school regardless of the locally titled position (i.e., school director, head teacher, etc.). Such individuals must hold a valid administrative certificate and comply with all applicable Act 45 and PIL requirements. In addition, the public school should properly identify the individual as a principal in PIMS/PERMS regardless of the local title utilized.

The Charter School assures that the Public School Code ( 24 P.S. § 11-1109) as well as any Act 45 continuing education and Pennsylvania Inspired Leaders (PIL) requirements are met as outlined above.

Affirmed on this \_\_\_\_\_ day of \_\_\_\_\_, 20\_\_\_\_

By: \_\_\_\_\_(Signature of Board President)

\_\_\_\_\_ (Print Name)

\_\_\_\_\_ Board of Trustees



# Identification of Students with Specific Learning Disabilities using Response to Intervention Assurance/Affirmation

If the Charter School has received approval from PDE to utilize a Response to Intervention method to identify students with Specific Learning Disabilities, the Charter School will assure implementation with fidelity for the duration of this plan.

Affirmed on this \_\_\_\_\_ day of \_\_\_\_\_, 20\_\_\_\_

By: \_\_\_\_\_(Signature of Board President)

\_\_\_\_\_ (Print Name)

\_\_\_\_\_ Board of Trustees

**Note:** Signature, Print Name and Board of Education are hard copy required (Board President must actually sign and complete).

Replace the following text in the header: LEA Name, Address, School Logo/Icon placeholder image.