

Pennsylvania Enhanced Driver Education Program Guide

Updated October 2018



**COMMONWEALTH OF PENNSYLVANIA
DEPARTMENT OF EDUCATION**

333 Market Street
Harrisburg, PA 17126-0333
www.education.pa.gov



Commonwealth of Pennsylvania

Tom Wolf, Governor

Department of Education

Pedro A. Rivera, Secretary

Office of Elementary and Secondary Education

Matt Stem, Deputy Secretary

Bureau of Curriculum, Assessment and Instruction

Brian Campbell, Bureau Director

Division of Instructional Quality

Brian Gasper, Division Chief

The Pennsylvania Department of Education (PDE) does not discriminate in its educational programs, activities, or employment practices, based on race, color, national origin, [sex] gender, sexual orientation, disability, age, religion, ancestry, union membership, gender identity or expression, AIDS or HIV status, or any other legally protected category. Announcement of this policy is in accordance with State Law including the Pennsylvania Human Relations Act and with Federal law, including Title VI and Title VII of the Civil Rights Act of 1964, Title IX of the Education Amendments of 1972, Section 504 of the Rehabilitation Act of 1973, the Age Discrimination in Employment Act of 1967, and the Americans with Disabilities Act of 1990.

The following persons have been designated to handle inquiries regarding the Pennsylvania Department of Education's nondiscrimination policies:

For Inquiries Concerning Nondiscrimination in Employment:

Pennsylvania Department of Education
Equal Employment Opportunity Representative
Bureau of Human Resources
Voice Telephone: (717) 783-5446

For Inquiries Concerning Nondiscrimination in All Other Pennsylvania Department of Education Programs and Activities:

Pennsylvania Department of Education
School Services Unit Director
333 Market Street, 5th Floor, Harrisburg, PA 17126-0333
Voice Telephone: (717) 783-3750, Fax: (717) 783-6802

If you have any questions about this publication or for additional copies, contact:

Pennsylvania Department of Education
Division of Instructional Quality
John V. Kashatus, School Safety Education Advisor
333 Market Street, Harrisburg, PA 17126-0333
www.education.pa.gov

All Media Requests/Inquiries: Contact the Office of Press & Communications at (717) 783-9802

Table of Contents

Module I—Administrative Guide	11
Acknowledgments	11
Introduction	12
Administration of Driver Education Programs	13
Program Requirements	13
Financial Support.....	14
Administrative Involvement	15
Personnel Qualifications	15
Standardized Program Requirements	16
Appendix A.....	22
Annual Preapproval of Driver Education PDE-3039 (May 2001).....	26
Annual High School Driver Education Report PDE-4026	29
Appendix B.....	30
Parent Survey.....	31
Student Survey I.....	34
Sample Questions.....	34
Student Survey II.....	37
Appendix C: Teaching Students with Disabilities.....	52
Introduction	53
Pennsylvania Physical Requirements/Licensing Issues.....	54
Program Structure - General Considerations.....	56
Adaptive Driving Equipment Vendors and Driver Education/Training Facilities	58
Module II - Decision Making Process	59
Introduction	59
Purpose.....	60
Driver Limitations	61
Human Errors	62
Process	64
STOP- THINK & GO Decision-Making Process.....	65
Right, Reality, & Responsibility	67
Practice	70

A Driving Dilemma	70
Decision-Making Worksheet.....	70
Processing the Dilemma	71
Reasons Why Students Fail to use Decision-Making.....	74
Decision-Making Applications.....	75
Case Situations.....	76
Exams.....	76
Slide Video Case Situations.....	76
Simulations	76
Role Plays.....	77
Crash Reenactments	78
Behind-the-Wheel Decision-Making	78
Activities	79
Activity: My Life Has Value.....	80
Activity: The Chair Jump	82
Activity: The Rope and Can	84
Activity: Creatures of Habit.....	87
Activity: Awareness of Risk	89
Activity: Responding to Risk.....	91
Activity: STOP- THINK & GO Decision-Making Process, Teaching the Model	95
Module III-- Perception and Driving Strategies for Different Environments.....	102
Perception and Driving Strategies for Different Environments	102
Rationale	102
Program Organization	103
Design and Structure	104
Scheduling Sessions.....	105
Terminology	106
Guidelines for Use of the Script.....	106
Use of introductory Masters	107
Flash-Slide Projection Guidelines	107
Case Study Slides.....	108
Evaluation of Student Achievement.....	108
Transfer of Training.....	108

Room Arrangement and Equipment.....	109
Perceptual Driving Program	109
Stated Reasons for Collision.....	110
Overall Goals of Program.....	110
Definition of a Low Risk Driver	110
Perceptual Driving Program Sessions.....	111
Session One: Improving Perceptual Skills	112
Session One Quiz.....	122
Session Two: Identifying Traffic Controls.....	128
Regulatory Signs.....	141
Warning Signs	142
Guide Signs	143
Traffic Control Signals.....	144
Pavement Markings	145
Right of Way Laws: Entering Unmarked or Open Intersections.....	146
Right-of-Way Laws: Entering Roadway from Driveways, Alleys and Parked Positions.....	147
Right-of Way Laws: Lane Ends or Is Obstructed.....	148
Right-of-Way Laws: Vehicles Turning Left Against Traffic.....	149
Right-of-Way Laws: Entering Intersections Controlled by Signs and Flashing Reds.....	150
Right-of-Way Laws: Intersections Controlled by Traffic Signal Lights.....	151
Right-of-Way Laws: Pedestrians Crossing Situations.....	152
Right-of-Way Laws: Entering and Passing Through Traffic Circles	153
Session Three: Identifying Highway Conditions	154
Less Space to Side	163
Changes in Space to Sides: Highway Conditions.....	163
Changes in Space to Sides: Other Traffic	164
Less Sight Distance Ahead: Less View to Sides	164
Changes in Sight Distance or View to Sides: Highway Conditions	165
Changes in Sight Distance or View to Sides: Other Traffic.....	165
Clues to Hidden Side Roads	166
Areas of Less Traction	166
Changes in Traction: Roadway Conditions.....	167
Changes in Traction: Surface Materials	167

Session Four: Identifying Other User Actions	168
Vehicle Condition and Performance	177
Clues to Change in Vehicle Movement	178
Driver Clues to Probable Actions	179
Clues to Motorcyclist Actions	180
Clues to Bicyclist Actions	181
Clues to Pedestrian Actions	182
Session Five: Identifying All HTS Events	183
Summary of First Five Sessions	188
Session Six: Identifying Closing Probabilities.....	189
Projected Path of Travel.....	201
Identify Probable Errors: Failure to Observe Laws	202
Identify Probable Errors: Improper Responses to Highway Conditions.....	203
Identify Probable Errors: Improper Responses to Other User Actions	204
Identify Probable Errors: Improper Vehicle Control Actions	205
Evaluate Conflict Probabilities of Other Users: Driver Actions are Very Limited	206
Evaluate for Conflict Probabilities: Identify Low Chance of Conflict	207
Evaluate for Conflict Probabilities: Identify High Chance of Conflict	207
Identify Probable Point of Conflict	208
Case of the Crossover	209
Case of the Right Turn Surprise.....	210
Case of the Off-Road Recovery	211
Session Seven: Responding to Problem Situations	212
Nature of Decision-Making.....	226
Plan of Action.....	227
Adjust Speed for Highway Conditions	227
Adjust Speed for Traffic Conditions	228
Adjust Speed for Time Needed	228
Choose Best Path of Travel	229
Communicate all Changes	230
Case of the Narrow Median	231
Case of the Merge Conflict.....	232
Case of the Hillcrest Hazard.....	233

Session Eight: Night Driving	238
Appendix A.....	249
Perception of HTS Events Answer Sheet	250
Answer Sheet for Case Study Evaluations	252
Appendix B.....	256
Case of the Truck Turning	257
Case of the Supermarket Shopper	257
Case of the Follow-tail Passer	258
Case of the Hidden Biker.....	258
Case of the Impatient Passer	259
Case of the Right Shoulder Hazard	259
Case of the Strong Crosswind	260
Case of the Oncoming Passer.....	260
Case of the Blocked View.....	261
Case of the Busy Ramp.....	261
Case of the Blindspot Driver	262
Case of the Crowded Freeway	262
Case of the Right-Side Passer	263
Case of the Hidden Motorcycle.....	263
Case of the Hidden Gravel Road	264
Appendix C.....	265
Checklist for 2--4-- 12 Time Distances.....	266
Checklist for Conflict Probabilities.....	269
Checklist for Timing Situations	271
Checklist for Choosing Best Pathway	275
Checklist for Identification of Highway Changes	279
Appendix D.....	286
Commentary Driving, Tell It Like You See It	287
Module IV—Other Classroom Units.....	289
Classroom Units of Instruction.....	289
Introduction	289
Responsibilities when entering Pennsylvania’s Driver Licensing System.....	290
Episode Justification	290

Episode Objectives	291
Performance Objectives	291
Content	292
Resources.....	296
Man-Made Laws	299
Episode Justification	299
Episode Objectives	299
Performance Objectives.....	299
Content	300
Resources.....	307
Natural Laws in Relation to Driving a Motor Vehicle	308
Episode Justification	308
Episode Objectives	308
Performance Objectives.....	308
Content	309
Resources.....	315
Psychological Conditions.....	316
Episode Justification	316
Episode Objectives	316
Performance Objectives.....	316
Content	316
Resources.....	319
Physiological Conditions.....	320
Episode Justification	320
Episode Objectives	320
Performance Objectives.....	320
Content	321
Resources.....	323
Adverse Conditions	324
Episode Justification	324
Episode Objectives	324
Performance Objectives.....	324
Content	326

Resources.....	330
Alcohol/Other Drugs	332
Episode Justification	332
Episode Objectives	332
Performance Objectives.....	332
Content.....	334
Resources.....	343
Financial Responsibility	348
Episode Justification	348
Episode Objectives	348
Performance Objectives.....	348
Content.....	349
Resources.....	351
Trip Planning	352
Episode Justification	352
Episode Objectives	352
Performance Objectives.....	352
Content.....	353
Resources.....	355
Buying/Maintaining a Car	357
Episode Justification	357
Episode Objectives	357
Performance Objectives.....	357
Content.....	358
Resources.....	362
Module V—Laboratory Instruction.....	363
Laboratory Instruction.....	363
Rationale.....	363
Definition of Terms.....	363
Methodology	364
Resources.....	366
Lesson Number One: Off-Street Lesson.....	368
Lesson Number Two: On-Street Lesson: Residential Area	373

Lesson Number Three: Off-Street Lesson	375
Lesson Number Four: On-Street Lesson: Open Highway	377
Lesson Number Five: On-Street Lesson: Moderate Traffic Urban Area	379
Lesson Number Six: On-Street Lesson: Expressway/Freeway	381
Lesson Number Seven: Off-Street Lesson	383
Lesson Number Eight: On-Street Lesson: Rural Roads.....	386
Lesson Number Nine: On-Street Lesson: Business District/Urban Setting.....	388
Lesson Number Ten: On-Street Lesson: Night Driving	390
Lesson Number Eleven: On-Street Lesson: Driver Evaluation	392
Appendix A.....	394
Laboratory Record.....	395
Appendix B	396
Practice Driving Log	397
Appendix C	398
Checklist for Basic Maneuvers	399
Checklist for Expressway Driving.....	400
Identification of Traffic Signs.....	402
Appendix D	410
Behind-the-Wheel Performance Objectives Driving Environment: Residential	411
Behind-the-Wheel Performance Objectives Driving Environment: Open Highway	412
Behind-the-Wheel Performance Objectives Driving Environment: Moderate Traffic/Shopping Centers.....	413
Behind-the-Wheel Performance Objectives Driving Environment: Expressway	414
Behind-the-Wheel Performance Objectives Driving Environment: Rural Roads.....	416
Behind-the-Wheel Performance Objectives Driving Environment: Vehicle Emergencies	417
Behind-the-Wheel Performance Objectives Driving Environment: Central Business District.....	418
Behind-the-Wheel Performance Objectives Driving Environment: Night Driving	420

Module I—Administrative Guide

Acknowledgments

This program guide was originally published in July of 2000 and developed under a grant provided by the National Highway Traffic Safety Administration through the Pennsylvania Department of Transportation and the Pennsylvania Department of Education. This program guide was the result of the Pennsylvania Enhanced Driver Education Curriculum that was developed and evaluated by Indiana University of Pennsylvania's Highway Safety Center.

The primary authors for the curriculum from Indiana University of Pennsylvania were Dr. Richard J. Homfeck and Dr. John C. Worzbyt. Other contributing writers to this curriculum were driver education teachers from throughout the Commonwealth who contributed a great deal of valuable time writing and reviewing segments of the curriculum. Members of the group were:

Tim Brant, Hiram G. Andrews Center

Paul Ehrhart, Methacton SHS

Paul Grosvenor, Elk Lake Senior HS

Brian Neffe, Southern Lehigh HS

Ralph Byers, Carlisle Area HS

Jim Frank, Susquehanna Township HS.

Dick Katz, Blue Mountain HS

Liz Rimpfel, Cumberland Valley HS.

Mark Correll, Boiling Springs HS

Royce Gerber, Dallastown Area SH

Mary Beth Morgan, Exeter SHS

The Department extends special thanks to the following individuals:

- Mr. H. David Secrist who was the contract manager for the Pennsylvania Department of Education and is currently retired;
- Mr. Thomas Bryer, Director of the Bureau of Highway Safety and Traffic Engineering for the Pennsylvania Department of Transportation was the grant administrator;
- Mr. Warren P. Quensel, Safety Enterprises, Bloomington, Illinois, provided many of the resources used in the visual training component; and
- Mrs. Brenda Treese Calhoun, Ms. Terri A. Kerfonta and Ms. Beth Bogden from the Indiana University of Pennsylvania's Highway Safety Center for all their secretarial skills and assistance.

In July of 2001, the Department revised this program guide and extends special thanks to:

- Mrs. Nancy Stekovich, Administrative Assistant for the Division of Curriculum and Instruction at the Pennsylvania Department of Education for her secretarial skills and assistance in revising the guide; and
- Mr. Robert Roush, Jr., School Safety Education Advisor for the Division of Curriculum and Instruction at the Pennsylvania Department of Education for his oversight and supervision of the revisions to the guide.

Introduction

The Pennsylvania Enhanced Driver Education (Curriculum Guide) is a result of the Pennsylvania Enhanced Driver Education Curriculum Project conducted by Indiana University of Pennsylvania's Highway Safety Center. Pennsylvania Department of Education's Bureau of Curriculum and Academic Services' School Safety Education contracted with Indiana University of Pennsylvania's Highway Safety Center to develop, implement, and evaluate an enhanced driver education curriculum. The enhanced curriculum focused on four major areas: decision-making, visual-training, night driving, and parent involvement. The evaluations for the curriculum were favorable which resulted in this revised Curriculum Guide.

The Curriculum Guide is presented in five modules, and it is imperative that instructors carefully examine each module before attempting to plan their driver education curriculum. The five modules and their description are:

Module I: Administrative Guide

This is the Administrative Guide for the Curriculum Guide. It is important to read this and understand it before proceeding into the other modules. This module not only gives you specific information concerning the new Curriculum Guide, but it also gives you everything you need to know as a program administrator.

Module II: Decision-Making Process

This is the STOP- THINK & GO Decision-Making Module. This is a classroom program, and it should be taught as one of the first units. The students will be learning a decision-making process and then be expected to apply it throughout the curriculum. It will usually take three or four classes to teach this process. It is important that the teacher carefully study all of the information for this unit, because it is critical to thoroughly understand it when teaching it to the students. Remember, this is a process that can be selectively applied throughout the curriculum. All of the information is available for the teacher to develop the lesson plans for this phase of instruction. Pages one through 34 are for the teachers to read and understand before attempting to use the learning activities starting on page 34.

Module III: Perception and Driving Strategies for Different Environments

This is the visual-training unit planned for the classroom. There is a great deal of structure associated with this phase of training, and it is important that the teacher become familiar with this program. The sessions are carefully planned with written content, training masters, and traffic slides. Once the teacher becomes familiar with the Perceptual Driving Program, then he/she can add to the content and also teach directly from the masters. This program is a tried and proven method of teaching visual skills and there is a definite transfer of learning when teaching in-car. You should teach this phase of instruction when students are acquiring their learner permits; thereby, the learning of concepts and practicing various visual skills will be more meaningful to students. This unit will require a large number of classes, but many of the

sessions can be related to other units. Students must learn, apply and practice these visual skills to be safe and efficient drivers.

Module IV: Other Classroom Units

These are the remaining classroom units that can be taught in the classroom phase of instruction. Some of the units and performance objectives can be coordinated with Module III. The format for this training module should enable the teacher to develop comprehensive lesson plans for each unit. All of these units should be familiar to the teacher and the amount of available time and the criticality of the selective performance objectives, should determine what needs to be taught in the classroom. It is imperative to carefully examine the entire Curriculum Guide before determining what should be taught and when it needs to be taught.

Module V: Laboratory Instruction

This is the laboratory phase of instruction, and it is only designed for in-car instruction. Driving Simulation and/or Multiple-Car Driving Range can either enhance the in-car instruction, or it can be substituted for parts of these lesson plans. The important point is that the teacher attempts to provide as many experiences as possible with the different environments. The lesson plans are structured and their objectives in many instances are directly related to the Perceptual Driving Program taught in the classroom. The lesson plans can be easily duplicated and should have specific information concerning the geographical areas in which the selective learning sets will occur.

Resources

There are a variety of resources that the teacher needs to acquire for personal use. There are also resources that the teacher needs to place in the hands of the students. A current textbook need to be identified and it should be one that relates to as many of the performance objectives as possible. The textbook is only one of the many resources that should be used in accomplishing the objectives.

Administration of Driver Education Programs

Program Requirements

The Commonwealth is responsible for ensuring the overall quality of driver education. Within the Commonwealth, the authority is delegated to the Department of Education (the Public School Code of 1949, Section 1519 Teaching of safe driving of motor vehicles). The Department is charged with approving and administering high school driver education programs in both public and private high school settings. The approved driver education program is a complete course of instruction including at least 30 clock-hours of classroom instruction and six hours of on-street-driving or its equivalent if adequate amounts of simulation and/or multiple-vehicle range instruction is provided.

The Department must adhere to the statutes of the Commonwealth and its own established policies and procedures. Under Section 1519.1 of the Public School of 1949, the Department is

required to establish a standardized driver education program and to perform specific management and program activities to facilitate implementation of driver education at the local district level.

Section 1519.1, Standardized Driver Education Program provides:

- a. The Department of Education shall establish, for operation in the public school system of the Commonwealth, a standardized driver education program in the safe operation of motor vehicles available to all public high school pupils and all high school pupils attending nonpublic high schools.
- b. The Department of Education shall assist school districts throughout the Commonwealth in the functioning of such program by:
 - I. preparation, publication and free distribution of driver education instructional material to insure a more complete understanding of the duties of motor vehicle operators; and
 - II. making such rules and regulations as may be necessary to carry out such program.

Financial Support

Driver education costs result from program administration, instruction, facilities, program equipment, materials, supplies, and other operation expenses. While the community receives the direct, immediate and long-range benefit of the program, state funds defray some of the costs.

State Funding

Under Section 2504.1 of the Public School Code of 1949, the Department of Education may reimburse school districts for students that complete the standardized driver education program during the school year. Funding for the reimbursement comes from the Motor Vehicle License Fund. The current level of reimbursement is set at \$35 per student. Districts are eligible for reimbursement if (1) district programs are approved in advance; (2) a standardized program of driver education is offered; (3) students receive 30 hours of classroom instruction and six hours behind-the-wheel instruction; (4) claims for reimbursement are appropriately documented (form PDE-4026) and submitted to the Department; and (5) students are eligible for the program.

Student eligibility and the authority of local districts to offer driver education are expressed in section 1519, Paragraph A, as follows:

"Any school district may provide for the teaching of safe driving of motor vehicles in the elementary and secondary schools only in accordance with the standardized program established by the Department of Education. In the case of students under the age of 16 years, such instruction shall be limited to classroom instruction by those who shall possess the qualifications prescribed by the State Board of Education. In the case of students 16 years and over, the instruction may include practical instruction in the operation of motor vehicles on the

public highways or other places selected by the board of school directors or by the principal of the school where the instruction is given."

Local Funding

The principal funding source for a quality driver education program is the local school district in driver education, as with any education service, districts can expect to make a financial contribution. Driver education, however, is unique in its offering of practical experience to students. Providing this experience is costlier than providing purely academic experiences.

Schools may elect to fund driver education, less the reimbursement amount, entirely from district funds. Also, under current law, a student laboratory fee may be assessed. The Department has determined that a laboratory fee is permissible if:

1. the fee and the operational expenses it covers are documented and justified;
2. the fee is determined by calculating operational expenses only (instructor salaries or benefits may not be used);
3. the fee is not a condition for enrolling in the course;
4. the information is placed on the preapproval form (PDE-3039).

Administrative Involvement

Administrative involvement at both the local and state level is needed to ensure a high-quality delivery of driver education programs. It must extend throughout the areas of program planning, implementation, and program monitoring and assessment.

A person or persons should be identified at the district level to provide for program administration support. Sometimes, this responsibility must be assumed by the driver education instructor. These duties may include the following:

- Advising the chief school administrator and school board members about the quality and needs of driver education.
- Developing annual programs and fiscal plans.
- Recommending policies and procedures for program operation.
- Recommending involvement with in-service programs, workshops, and state (Pennsylvania Association for Safety Education) and national (American Driver and Traffic Safety Education Association) conferences.
- Preparing a listing of instructional aids (e.g. videos, pamphlets, textbooks, etc.).
- Working with community organizations and agencies, especially automobile dealers and service clubs, to garner support and publicize the program.

Personnel Qualifications

Driver education instructional services may be offered by teachers and teacher aides (paraprofessionals). A public school employee hired/assigned to teach the approved standardized driver education program (30 & 6) must be a Pennsylvania certified driver

education teacher. Teacher aides (paraprofessionals) may only provide instruction in practice driving modes under the supervision of a certified driver education teacher.

A certified driver education teacher must hold a valid Pennsylvania teaching certificate based on State Board of Education requirements. Teachers must also complete at least 12 semester hours of college-level courses in driver and safety education. In addition, teachers must meet continuing certification requirements and maintain an exemplary driving record.

Public Schools may use aides who meet the examination requirements set by the Department of Education and other criteria established by law (Pennsylvania Public School Code of 1949, section 1519). Examination requirements include the satisfactory completion of a written theoretical test (driver's manual) provided by the Department of Education's Office of School Safety, at the request of the applicant and a local school district, and a practical (on-road) driving test at a Department of Transportation Examination Center.

Applicants must also be high school graduates with a clean driving record (no violations or accidents for the past three years) and must have completed a three-credit course in Driver and Traffic Safety Education. Additional requirements for teacher aides include (1) completing nine additional credit hours in Driver and Traffic Safety Education within three years of employment, and (2) be eligible according to the provisions of the Public School Code of 1949, section 1519.

Driver and Traffic Safety Courses are offered at the following state university:

Indiana University of Pennsylvania. Three credit courses consist of the following topics: "Foundations of Safety and Emergency Health Care;" "Introduction to the Driving Task;" "Driver Education Program Management;" and "Application of the Driver Education Instructional Modes."

Standardized Program Requirements

To administer Section 1519 of the Pennsylvania School Code of 1949 (Teaching of Safe Driving of Motor Vehicles), the Department of Education has established requirements for a standardized program. The standardized program is defined in terms of basic program elements, methods, and instructional time, program content, and administrative practices. The standardized program establishes minimal requirements in each of these areas. Schools may, and are encouraged to, provide a driver and traffic safety education course that exceeds the minimum requirements.

School districts may provide a course in driver education only in accordance with the standardized program established by the Department. All school districts are required to submit the Annual Preapproval of Driver Education form (PDE-3039). If the school district offers only one phase of instruction (classroom or behind-the-wheel), they must still submit a preapproval form to the Department and provide a certificate of satisfactory achievement for the student. In conducting approved courses, districts may qualify for state reimbursement, and school boards may appropriate and expend school district monies to conduct their driver education program. The course of driver education shall be offered at the grade level where most pupils are of, or closely approaching, minimum legal age for obtaining a learner's permit.

The standardized driver education program consists of a minimum of 30 hours of classroom instruction and a minimum of six hours of practice driving. Driving simulation instruction and multiple-car driving range instruction can be used to enhance the laboratory instruction and also in lieu of a portion of the practice driving time. The ratio of simulation instruction to practice driving instruction is either 4:1 or 3:1, and this is determined by how it is scheduled. The ratio of multiple-car driving range instruction to practice driving instruction is 2:1.

Methods and Instructional Time

Classroom Mode- The classroom mode shall be a minimum of 30 clock hours of classroom instruction. No student shall receive more than two hours of classroom instruction during any calendar day. The learning experiences presented shall be those represented in the Curriculum Guide.

The classroom units of instruction are:

- Decision-Making Process
- Perception and Driving Strategies for Different Environments
- Responsibilities When Entering Pennsylvania's Driver Licensing System
- Man-Made Laws
- Natural Laws in Relation to Driving a Motor Vehicle
- Psychological Conditions
- Physiological Conditions
- Adverse Conditions
- Alcohol/Other Drugs
- Financial Responsibility
- Trip Planning
- Buying/Maintaining a Car

In-Car Mode- The practice driving mode shall be a minimum of six clock hours for behind-the-wheel instruction in an approved driver education vehicle. Instruction shall occur in both an off-street area and on-street on designated driving routes. No student shall receive more than one hour of behind-the-wheel instruction during any calendar day. There are no designated time requirements for students who are observing while another student is driving. The learning experiences presented shall be experiences necessary to develop a safe and efficient driver. Module V: Laboratory Instruction identifies all of the objectives and learning experiences that a teacher should attempt to plan for his/her students.

Driving Simulation Instruction- This laboratory method of instruction can complement the in-car phase of instruction and also in lieu of a portion of the practice driving time. If the driving simulation instruction is scheduled in one block of time the ratio to practice driving instruction is 4:1. If the driving simulation is scheduled concurrently with the practice driving instruction, the ratio is 3:1. Concurrent scheduling is when the students move from the simulation laboratory to the driver education vehicle and then repeat this process. If simulation is being used in lieu of

practice driving time, the student must receive a minimum of three hours of behind-the-wheel instruction in the driver education vehicle on street/road.

Multiple-Car Driving Range- This laboratory method of instruction can complement the in-car phase of instruction and also in lieu of a portion of the practice driving time. The ratio to practice driving time is 2:1. If this laboratory method is used in lieu of practice time, the student must receive a minimum of three hours of behind-the-wheel instruction in the driver education vehicle on street/road.

Three Phase Laboratory Programs-If a state approved driver education program is teaching with in-car, driving simulation, and multiple car driving range, there must be a minimum of two hours of behind-the-wheel instruction in the driver education vehicle on street/road. The other four hours can be supplemented with a combination of simulation and driving range instruction.

Driver Education Motor Vehicles

Educational organizations conducting the Standardized Driver Education Program may obtain driver education motor vehicles by free loan, by lease, or purchase from interested cooperating motor vehicle dealers. Any such motor vehicle should not be more than five model years old. Driver Education vehicles shall be equipped with: (1) extra operable brake pedal; (2) an extra operable clutch pedal in a standard shift vehicle; (3) left and right-side view mirrors; (4) a rear view mirror; (5) instructor's (eye check) mirror and rearview mirror; and (6) cushions and other appropriate special equipment that may be necessary for physically challenged learning drivers. Two/three-wheel motor vehicles shall be equipped with left and right rear view mirrors attached to the handlebars.

Motor vehicles shall be insured at the following minimums: \$100,000/\$300,000 liability,

\$50,000 Property Damage, Personal Injury Protection and any other insurance protection as required in section 104 of the act of July 19, 1974. P.L. 489, No.176 known as the "Pennsylvania No-Fault Motor Vehicle Insurance Act".

Any motor vehicle used for practice driving purposes on the public highways of the Commonwealth shall be equipped with a least two STUDENT DRIVER signs, at least equal in size to the license plate of said motor vehicle.

Program Forms

See Appendix A for information and copies of the two required forms, PDE-3039 Annual Preapproval of Driver Education and PDE-4026 Annual High School Driver Education Report.

Program Assessment

Assessment is essential to the development and continued improvement of quality driver education programs. When conducted with the goal of improving programs and instruction, assessment and evaluation become the means whereby the continued quality of programs can be ensured.

One of the most important components to assess is the curriculum. Ongoing assessment of curriculum can help determine whether changes are needed. As always, planners need to be aware of local needs while striving for optimum program quality given those local factors. Every program should have a formal, written curriculum with clearly stated objectives. These objectives, in turn, should serve as the guide for program content and instruction.

Assessment can also be used to evaluate whether the program is keeping pace with changes in the field. Some questions administrators may want to consider include the following: Is the program content current? Are students provided instruction in the latest technological and mechanical innovations in automotive or highway engineering? Does the curriculum reflect up-to-date laws? Are instructional resources, such as simulators, films, videos, and other instructional aids current? Are program instructors taking part in regular, ongoing training and development in the field?

The instruction itself is another component that should be assessed. Assessment ought to help instructors and administrators provide an environment and use instructional strategies conducive to learning for all students. An assessment of educational strategies can pose the following questions: Are a variety of instructional strategies incorporated in the classroom phase of a driver education program? Are they the most appropriate strategies? Are they effective? Those assessing an educational program need to consider what instructional strategies are most effective for a specific topic or content area. For example, it would be more appropriate to have students engage in problem solving situations rather than rely solely on lectures in order to help students develop problem solving skills.

Another component worth reviewing is student assessment. How are students assessed in the driver education program? What must students know or be able to do in order to successfully complete the program? What criteria are used in the evaluation of students? What types of assessments are used to evaluate student's knowledge and skill levels? Do assessment and test results actually measure those objectives? Are alternative assessments offered for those with special needs?

Programs should also seek feedback from parents and students, especially former students who have since obtained their licenses and have gained driving experience. These students will be able to provide valuable feedback as to whether the program adequately met their needs.

Many local districts evaluate their driver education programs on a continuing and periodic basis. All districts are encouraged to evaluate programs within their capabilities with an eye toward program improvement.

Typical district evaluation activities include:

- Fiscal monitoring to identify potential for increased efficiency without diminishing effectiveness.
- Auditing of objectives to ensure the quality of instruction.
- Monitoring of service availability to determine if students are provided instruction without delay or without having to turn to alternative instructional services.

- Student performance as determined through program knowledge and performance tests.
- Course effectiveness as determined through analysis of grades received by students.
- Program needs as identified by instructor observation and comments from the community.

Districts should also consider program evaluation in specific areas of interest. The following list contains items that should be considered. Districts may add to the list based on local experience.

- There is a person in a supervisory capacity responsible for driver education.
- Classroom instruction is required of all students enrolled in the high school.
- Driver education is offered as a regular course in the high school.
- Scholastic credit is given for the driver education course.
- The course of study is reviewed and revised annually.
- Media and other visual aids are available and used.
- Practice driving is offered during school hours.
- Students are provided with laboratory experience in varying types of traffic and other conditions.
- Driver education vehicles are available in sufficient quantity to avoid schedule delays.
- Students are acquainted with supplementary materials that will enrich their classroom work.

Examples of student and parent/guardian survey forms are in Appendix B.

Parent/Guardian Involvement

Pennsylvania's Graduated Driver Licensing Program requires the 16 and 17-year-old to drive on a Learner's permit for a minimum of six months. During this six-month period, the parent/guardian is required to provide a minimum of 65 hours of skill-building, including no less than 10 hours of nighttime driving and five (5) hours of bad weather driving, of supervised practice on the learner's permit. When the student is ready to begin the laboratory phase of instruction, the student's parents/guardians should be brought into the teaching/learning process. This meeting should be mandatory for the student to begin the laboratory phase.

The instructor should schedule a meeting with the parents/guardians and the students to explain the respective roles and responsibilities of the instructor, the students, and the parents/guardians. The meeting should take no longer than 40 to 45 minutes. The meeting should be scheduled for the middle of the week in the evening and a make-up day for the following Saturday morning. If a parent/guardian is not able to make either of these meetings, then an individual meeting should be scheduled. During the meeting, lines of communication need to be established so that all three parties are aware of the planned progression of learning for the new driver.

Information for parents should include the following:

- A course syllabus for the classroom theory and behind-the-wheel instruction.
- Lesson plans and objectives.

- Descriptions of the driving environments and anticipated problems or errors.
- Laboratory manuals used for instruction, e.g. "Handbook for Learning to Drive" & "How to be a More Perceptive Driver."
- Individual driving log (how entries are made by the instructor and the parents).
- A review of the state Graduated Driver License regulation.
- Examples of Parent Guides and the procedures for using them.
- The PENNDOT Tutor Guide "The Parent's Supervised Driving Program."
- A recommendation that parents contact their insurance company for a parent guide.
- Guidelines for observing and instructing beginning drivers.
- Documenting the observation hours in the driving log.
- Accessing resource material from the internet.
- Crash data regarding causes of crashes and fatalities for 16 and 17-year-old drivers.
 - Crash types where young drivers are over represented:
 - Safely driving on wet pavements.
 - Driving with passengers causing distractions.
 - Pulling out from a stop sign.
 - Safely turning left across traffic.
 - Maintaining a safe distance between vehicles.
 - Negotiating highway curves safely day and night.
 - Maintaining vehicle control- effects of speeding.
 - Changing lanes safely and passing.

Appendix A

- PDE - 3039, Annual Preapproval of Driver Education
- PDE - 4026, Annual High School Driver Education Report

Program Forms

The report forms presented in this section are designed as administrative tools to help the Department of Education and the school districts to define instructional programs and determine reimbursement.

Required Forms

The Department of Education provides two forms which must be completed and filed with the Department:

- PDE-3039- Annual Preapproval of Driver Education
- PDE-4026 - Annual High School Driver Education Report

These forms are accessed through [MyPDESuite](#) where program supervisor will access the DriverEd Application to navigate to the forms.

PDE-3039-Annual Preapproval of Driver Education

Information captured by this form provides an overview of program offering within a school district. It constitutes a prospectus of the course as it will be administered throughout the school year, describing, forecasting the number of students, the type and length of instruction to be offered, when instruction will occur, the types of vehicles to be used, the names of certified instructors, instructor scheduling, etc. The Department reviews and approves each school district program and prepares an approved directory for the Bureau of Motor Vehicles and the general public. The Bureau of Motor Vehicles consults the directory before issuing regular licenses to 17-year-old students who have submitted DL-59 forms.

Only programs approved by the Department's Safety Office are listed in the [Department of Education's Driver and Safety Education website](#). Programs consisting of 30 hours of classroom instruction and six hours behind-the-wheel (Standardized Program) may be approved with or without reimbursement. Partial programs like 30 hours of classroom instruction may only be approved without reimbursement. All school districts must complete and submit a PDE-3039 form by September 15th.

School districts that do not provide a driver education program are asked to register as NO PROGRAM in the Program Information Tab and submit to the Department of Education's School Safety Education Office.

MEMO

Subject: Annual Preapproval of Driver Education (PDE-3039)

To: District Superintendents
Intermediate Unit Executive Directors
Area Vocational-Technical School Principals
Diocesan Secondary School Principals
No Diocesan Secondary School Principals

The School Safety Education Office will continue to approve driver education programs via the MyPDESuite Portal and the DriverEd Application. Please provide all of the information requested. The "standardized driver education program" has been defined clearly as..."minimum 30 hours of classroom instruction and a minimum of 6 hours of behind-the-wheel instruction," with instruction provided by a certified and/or approved instructor. Please note that you can access and complete PDE-3039 on- line at: <https://www.mypdeapps.pa.gov>

If your yearly classroom schedule does not provide for 30 hours (1800 minutes) of classroom instruction, due to intensive scheduling, a 6-day cycle or 42-minute classes once a week as an example, you may provide supplemental instruction by way of driver and safety education assembly programs to meet the minimum 30 hours of classroom instruction requirement. Examples: speakers from the PA State Police, Driving Under the Influence Association, Mothers Against Drunk Driving, Students Against Driving Drunk, Insurance Companies, the American Academy of Pediatrics and the Comprehensive Highway Safety Centers. If offering large group instruction, attach a brief outline including topic, presenter, total minutes and date for each

session. A maximum of 5 hours of supplemental instruction *is* permitted to meet the 30-hour requirement for classroom instruction.

Data from your schools is necessary for compliance with state regulations, planning budgets, developing programs and revising the state directory of approved driver education programs. As changes occur during the school year, please report the revisions to the School Safety Education Office.

The approved list of approved School Districts and Private Driver Training Schools is used by the Bureau of Motor Vehicles, Pennsylvania Department of Transportation (PENNDOT) for issuing regular licenses at age 17 1/2, insurance companies for approving premium discounts, and automobile manufacturers to confirm the program approval when providing subsidies to cooperative dealers. [Department of Education's Driver and Safety Education website](#).

PA Public School Code of 1949, Section 1519 (24 PS 15-1519) provides for driver training programs. It states that any school district may provide for the teaching of safe driving of motor vehicles in the elementary and secondary schools of the district or in the secondary schools only, in accordance with the standardized program established by the Department of Public Instruction (PDE).

Information which may be of interest to you concerning driver education follows:

1. Parents may receive an approximate 10-20 percent reduction in insurance premium discounts upon their son or daughter completing an approved driver education program. This 10-20 percent savings could be for each year over an 8-9 year period of time. The savings would be only on the rated student and not their entire policy.
2. School districts may charge students a "lab fee" for operational costs of the motor vehicle. This fee cannot include salaries or fringe benefits for instructors. The lab fee is based upon your "lab fee justification" which is to be completed on your PDE-3039 form, (THE LAB FEE MAY NOT EXCEED THE JUSTIFIED COST PER STUDENT IF REIMBURSEMENT IS REQUESTED). POE will review your justification to be certain that all items are valid as part of the approval process.
3. The amount of reimbursement is \$35.00 per student (Section 2504.1 of the PA, Public School Code of 1949) from the Motor License Fund. School districts charging students a fee to attend summer school in addition to a "lab fee" are not eligible for the reimbursement.
4. Personal financial hardship must not Prevent a student from participating in the driver education program; thereby, the "lab fee" must not be a condition for enrolling in the course.
5. There *is* no age limit for driver education vehicles, however new models are recommended because they are equipped with modern safety equipment and new technology.
6. If you are contracting with a private driver training school, you must complete the Program Instructor information under the "Instructors" Tab on your Annual preapproval (PDE-3039). REMINDER: THE SCHOOL DISTRICTS MUST HAVE ACT 34 CLEARANCES FOR ALL CONTRACTED EMPLOYEES.

7. Classroom instruction: instruction may be offered in a variety of class sessions, as long as (1) each student receives 30 hours of instruction and (2) no student receives more than two hours of class instruction during any calendar day.
8. Practice driving: instruction may be offered in a variety of time segments, provided that (1) each student receives at least 6 hours of instruction as a vehicle operator, and (2) no student receives more than one hour behind-the-wheel instruction in vehicle operation during any calendar day.
9. Please refer to the Enhanced Driver Education Program Guide for information on program rationale, curriculum structure, curriculum units and program support and administration.
10. School administrators and driver education instructors are reminded to maintain accurate records of time for each student (A driving log sheet is recommended) enrolled in the driver education program (30 hours classroom theory and 6 hours behind-the-wheel instruction), in order to validate reimbursement information during periodic school audits, by the Auditor General's Office.

Please submit the preapproval (PDE-3039) form to ensure that your school will be listed accurately at the Department of Education. If driver education is *not* offered, the chief school administrator should mark "no program" in the "Preapproval" Tab and submit to PDE.

Annual Preapproval of Driver Education PDE-3039 (May 2001)

Program Approval Will Be Provided by the School Safety Education Office

INSTRUCTIONS: Log into the MyPDESuite, navigate to the DriverEd Application, complete all applicable tabs and submit to PDE by September 15. You can access your Preapproval Summary Report under the "Submit" tab and retain a copy for your file.

Complete all items. If non-applicable, use N/A. All school districts are requested to complete this form. If no program is provided, please indicate NO PROGRAM in the "Preapproval" Tab, click "save" and submit to PDE

Program Supervisor Information Tab

Complete All items.

Program Supervisor, Job Title, Name, Email address, Phone Number, Extension, Fax Number

Preapproval Tab

Program Information: Check appropriate box(es) and complete each item.

- Classroom Instruction/Practice Driving
- Classroom Instruction Only
- Practice Driving Only
- No Program

A standardized driver education program shall consist of a minimum of thirty hours of classroom instruction and six hours of practice driving instruction, exclusive of observation time.

1. The school district agrees to provide the standard program as defined
Yes No
2. The program in public school districts is available to all eligible school students (public and nonpublic).
Yes No

'Yes' must be checked in 1 & 2 if reimbursement is requested.

Classroom Instruction Tab

Enter the anticipated student enrollment

Classroom instruction:

- Number of minutes per class
- Number of class periods
- Total hours per student

- Hours of supplemental instruction: Name of Presenter, Program Topic, Length of Time, Date.
- Classroom instruction will be scheduled:
 - Regular school day
 - Before or after school
 - Evening
 - Saturdays
 - Summer

Practice Driving Tab

Practice Driving Anticipated Enrollment

Behind the wheel instruction:

- Number of minutes per lesson
- Number of lessons
- Total hours per student

Simulation instruction : Hours Ratio: (please circle) 3:1 (concurrent program) 4:1

Multiple car range : Hours Ratio: 2:1

Cars are equipped with:

Dual control brake (clutch if appropriate) Yes No

Instructor side and rearview mirrors: Yes No

Practice driving will be scheduled:

- Regular school day
- Before or after school
- Evening
- Saturdays
- Summer

Is a lab fee charged to offset the operating expenses of the automobile?

Yes No Amount per student:\$

Lab fee justification. (Lab fee may not exceed justified cost per student, if requesting reimbursement.) In the space below itemize your operational expenses (instructional salaries and benefits may not be included)

Expenses

1. Lease or pro-rated purchase:
2. Gasoline
3. Insurance

4. Service/Maintenance/Repairs
5. Total Expenses (divided by number of students=cost per student)

If you are contracting with a Private Driver Training School, Community College, AVTS, or Intermediate Unit, for any part of Driver Education you must indicate such under the Instructors Tab (School Districts must have Act 34 clearance for all contracted employees).

Instructors Tab

Classroom Instruction and/or Practice Instruction

- Instructor PPID
- Instructor Name- First Middle Initial Last
- Instructor Email Address
- Certification
 - PA certified driver education teacher
 - Letter of eligibility
 - Provisional letter of eligibility
 - None of the above

In accordance with the Educator Discipline Act (24 P.S. §§ 2070.1a-2070.19) as amended by SB 34, which became effective February 18, 2014. SB 34 expanded the educator discipline process to include all contracted educational providers and contracted educational provider staff members who provide direct educational services to students under a contract with a school entity and who would be required to hold certification if they worked in a public school.

Submit Tab

CERTIFICATION STATEMENT AND SUBMISSION: A course in driver education will be conducted, as described in this report, in accordance with Section 1519.1 of the PA School Code of 1949. The district's Driver Education curriculum incorporates the Driver Education Content and Performance Expectations as adopted by the Pennsylvania Department of Education.

By checking the box, you certify that the above statement is true to the best of your knowledge.

Annual High School Driver Education Report PDE-4026

The PDE-4026 must be completed if schools wish to obtain reimbursement from the Motor License Fund. It provides the Department with statistical data concerning the number and types of students, (i.e., public, non-public, and vocational-technical) receiving driver education in a school district during the school year. The form also captures the information regarding when classroom and practice driving instruction was offered within the district

The form is to be completed via the MyPDESuite, DriverEd Application The PDE-4026 form must be submitted to the Department of Education's School Safety Education Office by September 15 of each year if the school district is requesting reimbursement. A copy of the information provided on the Driver and Safety Education web page as follows.

Reimbursement Data

1. Number of public pupils completing the standardized program of classroom instruction and practice driving (minimum 30 hours classroom and 6 hours of practice driving instruction (\$35.00/pupil)
2. Number of nonpublic pupils completing the standardized program of classroom and practice driving provided by this school district (\$35.00/pupil)
3. Number of non-public pupils completing only the practice driving at this school district. (classroom certificate required)
4. Total Payable:

Save and Submit to PDE

Appendix B

- Parent Survey
- Student Survey I
- Student Survey II

Parent Survey

This survey should be given to the parent immediately after their respective student has completed both the classroom and laboratory phases of driver education. The respondent remains anonymous and responses can be made on the survey instrument or a separate scoring sheet. As an instructor, you can edit, add or delete any of the following questions. This survey is evaluating the overall quality of the driver education program.

Sample Questions

After completing the classroom phase and in-car phase of driver education, how much difficulty, if any, did your son/daughter have with the situations identified in one through 14? Please respond to each numbered situation on the answer sheet with the following:

- A. None
 - B. Some difficulty
 - C. Extreme Difficulty
 - D. Did not experience or practice situation
-
1. Maintaining a safe following distance?
 2. Accelerating and braking with a smooth action?
 3. Maintaining a safe speed and correct lane position when making left and right turns?
 4. Passing and overtaking other vehicles?
 5. Entering an expressway?
 6. Exiting an expressway?
 7. Driving at night?
 8. Driving in bad weather conditions?
 9. Judging a safe speed for various traffic conditions?
 10. Judging space needed for steering and/or braking?
 11. Identifying traffic lights, signs and markings well in advance?
 12. Seeing or recognizing hazards in time to respond?
 13. Selecting a sufficient gap in traffic when pulling into an intersection?
 14. Being aware of traffic behind and to the sides?

Answer Accordingly

1. Are you comfortable and relaxed when riding as a coach with your son/daughter?
 - a. Very comfortable
 - b. Somewhat comfortable
 - c. Somewhat uncomfortable
 - d. Very uncomfortable

2. Approximately how much supervised practice time did you give your son/daughter when learning with the driver education instructor?
 - a. 0-6 hours
 - b. 7-12 hours
 - c. 13-18 hours
 - d. 19-24 hours
 - e. 25-30 hours
 - f. 31-36 hours
 - g. 37 or more hours
3. Do you need to remind your son/daughter to buckle his/her safety belt when either driving or riding as a passenger?
 - a. Yes
 - b. No
4. What is your opinion of the overall classroom and in-car driver education instruction that your son/daughter received?
 - a. Very worthwhile
 - b. Somewhat worthwhile
 - c. Not too worthwhile
 - d. Not at all worthwhile
 - e. No opinion
5. In general, how worthwhile was the classroom phase of driver education that your son/daughter received?
 - a. Very worthwhile
 - b. Somewhat worthwhile
 - c. Not too worthwhile
 - d. Not at all worthwhile
 - e. No opinion
6. In general, how worthwhile was the in-car phase of driver education that your son/daughter received?
 - a. Very worthwhile
 - b. Somewhat worthwhile
 - c. Not too worthwhile
 - d. Not at all worthwhile
 - e. No opinion
7. Do you feel that the classroom and in-car driver education enabled your son/daughter to become a better driver?
 - a. Strongly agree
 - b. Agree
 - c. Disagree
 - d. Strongly Disagree

8. Were you satisfied with the way your son/daughter was scheduled for the classroom and in-car driver education instruction?
- a. Extremely satisfied
 - b. Somewhat satisfied
 - c. Somewhat dissatisfied
 - d. Extremely dissatisfied
9. Do you feel that all 16 and 17 year olds should be required to successfully complete a state approved high school driver education course as a requirement for licensing?
- a. Strongly agree
 - b. Agree
 - c. Disagree
 - d. Strongly Disagree
10. How knowledgeable are you about your son/daughter's driver education program?
- a. Very knowledgeable
 - b. Somewhat knowledgeable
 - c. Not very knowledgeable
11. Did you attend a driver education parent's meeting?
- a. Yes
 - b. No
12. If you attended the driver education parents meeting, did you feel that the meeting was worthwhile?
- a. Very worthwhile
 - b. Somewhat worthwhile
 - c. Not too worthwhile
 - d. Not at all worthwhile
 - e. No opinion
 - f. Did not attend
13. If you did not attend the driver education parents meeting, what was your reason?
- a. Meeting time was inconvenient
 - b. Did not know of the meeting
 - c. Not interested
 - d. Individual meeting with teacher

Student Survey I

This survey should be given to the student immediately after completing both the classroom and laboratory phases of driver education. The respondent remains anonymous and responses can be made on the survey instrument or a separate scoring sheet. As an instructor, you can edit, add or delete any of the following questions. This survey is evaluating the overall quality of the driver education program.

Sample Questions

1. Please indicate your gender:
 - a. Female
 - b. Male
2. Please indicate your current grade:
 - a. 9th
 - b. 10th
 - c. 11th
 - d. 12th

After completing the classroom and in-car instruction of driver education, how much of a problem did you have with the following situations identified in 3 through 16? Please respond to each numbered situation on the answer sheet with the following:

- A. None
 - B. Some difficulty
 - C. Extreme difficulty
 - D. Did not experience or practice situation
-
3. Maintaining a safe following distance?
 4. Accelerating and braking with a smooth action?
 5. Maintaining a safe speed and correct lane position when making left and right turns?
 6. Passing and overtaking other vehicles?
 7. Entering an expressway?
 8. Exiting an expressway?
 9. Driving at night?
 10. Driving in bad weather conditions?
 11. Judging a safe speed for various traffic conditions?
 12. Judging space needed for steering and/or braking?
 13. Identifying traffic lights, signs and markings well in advance?
 14. Seeing or recognizing hazards in time to respond?
 15. Selecting a sufficient gap in traffic when pulling into an intersection?
 16. Being aware of traffic behind and to the sides?

17. Do you wear your safety belt every time you drive a car/truck?
- Yes
 - No
18. Do you wear your safety belt every time you ride in the front seat of a car/truck as a passenger?
- Yes
 - No
19. Do you wear your safety belt every time you ride in the back seat of a car as a passenger?
- Yes
 - No
20. In your opinion, how worthwhile was the classroom phase of driver education that you received?
- Very worthwhile
 - Somewhat worthwhile
 - Not too worthwhile
 - Not at all worthwhile
21. In your opinion, how worthwhile was the in-car phase of driver education that you received?
- Very worthwhile
 - Somewhat worthwhile
 - Not too worthwhile
 - Not at all worthwhile
22. Do you feel that your driver education program enabled you to become a better driver?
- Strongly agree
 - Agree
 - Disagree
 - Strongly Disagree
23. Were you satisfied with the way you were scheduled for the classroom and in-car driver education instruction?
- Extremely satisfied
 - Somewhat satisfied
 - Somewhat dissatisfied
 - Extremely dissatisfied
24. Do you feel that all 16 and 17 year olds should be required to successfully complete a state approved high school driver education course as a requirement for licensing?
- Strongly agree
 - Agree
 - Disagree
 - Strongly Disagree
 - No opinion

25. My teacher for the classroom phase of driver education exhibited interest and enthusiasm for the subject?
- a. Very much
 - b. Somewhat
 - c. Very little
26. My teacher for the in-car phase of driver education exhibited interest and enthusiasm for this instruction?
- a. Very much
 - b. Somewhat
 - c. Very little
27. I would rate my teacher for the classroom phase of driver education as:
- a. Superior
 - b. Above Average
 - c. Average
 - d. Below Average
 - e. Poor
28. I would rate my teacher for the in-car phase of driver education as:
- a. Superior
 - b. Above Average
 - c. Average
 - d. Below Average
 - e. Poor

Student Survey II

This survey should be given to the student a minimum of six months and a maximum of 12 months after receiving his/her restricted license. The respondent remains anonymous and responses can be made on the survey instrument or a separate scoring sheet. As an instructor, you can edit, add or delete any of the following questions. This survey is attempting to evaluate the overall effectiveness of the driver education program. Part I gives general demographics, Part II gives exposure, Part III gives violation experience, and Part IV and V give collision experience. The students completing this survey should primarily be in the 12th grade, second semester.

Sample Questions

PART I

General Information Pertaining to the New Driver

Please indicate your gender:

- a. Female
 - b. Male
2. Please indicate your current grade or the grade you just completed:
- a. 9th
 - b. 10th
 - c. 11th
 - d. 12th
3. What was your age when you received your learner's permit?
- a. 16 years to 16 years 5 months
 - b. 16 years 6 months to 16 years 11 months
 - c. 17 years to 17 years 5 months
 - d. 17 years 6 months to 17 years 11 months
4. How many months did you drive on your learner's permit before you passed your driver's exam?
- a. Six months
 - b. Seven months
 - c. Eight months
 - d. Nine months
5. How many attempts did you need to pass your driver's exam?
- a. One attempt
 - b. Two attempts
 - c. Three attempts
 - d. More than three attempts

6. Since receiving your restricted license how long have you been driving?
- a. Less than six months
 - b. Six months to less than nine months
 - c. Nine months to less than a year
 - d. One year or more
7. Whose car do you usually drive?
- a. Own
 - b. Parent's
 - c. Relative's
 - d. Friend's
 - e. Employer's
 - f. Other

PART II

8. In relation to your home, where does most of your driving occur?
- a. Within 15 miles
 - b. Within 30 miles
 - c. Within 45 miles
 - d. Within 60 miles
 - e. Within 75 miles
 - f. Within 90 miles
 - g. More than 90 miles
9. On what type of highways or streets do you do most of your driving?
- a. City/Business streets
 - b. City/Residential streets
 - c. Expressways/Freeways
 - d. Rural Two Lane Highways
 - e. Rural Blacktop or Gravel Roads
10. How often do you drive to school?
- a. Almost every day
 - b. Usually once or twice a week
 - c. Rarely
 - d. Never
11. With whom do you do most of your driving?
- a. Alone
 - b. Parents
 - c. Relatives
 - d. Friends
 - e. Employer or workers

12. During the week (Monday to 6:00p.m. Friday), when do you most do your driving?
- a. Morning
 - b. Afternoon
 - c. Nighttime
 - d. Mornings and afternoons
 - e. Afternoons and nighttime
 - f. Mornings and nighttime
13. How much of your driving is done on weekends? (Friday evening, 6:00p.m. or later, Saturday, Sunday)
- a. Less than 20%
 - b. 20%-40%
 - c. 40%-60%
 - d. 60%-80%
 - e. 80%-100%
14. On weekends, when do you do most of your driving?
- a. Morning
 - b. Afternoon
 - c. Nighttime
 - d. Mornings and afternoons
 - e. Afternoons and nighttime
 - f. Mornings and nighttime
15. About how much time do you spend driving during an average week? (Monday-Sunday)
- a. 0-4 hours
 - b. 5-9 hours
 - c. 10-14 hours
 - d. 15-19 hours
 - e. 20-24 hours
 - f. 25-29 hours
 - g. 30 or more hours
16. Do you wear your safety belt at all times when driving a motor vehicle?
- a. Yes
 - b. No
17. Do you wear your safety belt at all times when riding as a passenger in a motor vehicle? (Does not include a bus.)
- a. Yes
 - b. No

PART III

If you have been given a citation by a police officer and you paid the fine, then this represents a moving violation. Please report this experience whether it happened in Pennsylvania or another state. Complete anonymity is guaranteed. A parking ticket does NOT constitute a moving violation.

18. Have you been cited for a moving violation(s) as a driver?

- a. Yes
- b. No

19. How many moving violations have you had?

- a. None
- b. 1
- c. 2
- d. 3
- e. 4 or more

20. How many points have you accumulated?

- a. None
- b. 1
- c. 2
- d. 3
- e. 4
- f. 5
- g. 6

21. Have you ever had your driver's license suspended?

- a. Yes
- b. No

22. Have you been arrested and convicted for underage drinking?

- a. Yes
- b. No

23. Have you been cited for exceeding the posted speed or driving too fast for conditions?

- a. Yes
- b. No

24. Have you been cited for failing to yield?

- a. Yes
- b. No

25. Have you been cited for a traffic light or stop sign violation?

- a. Yes
- b. No

26. Have you been cited for improper passing?
- a. Yes
 - b. No
27. Have you been cited for not wearing your safety belt?
- a. Yes
 - b. No

PART IV—COLLISION EXPERIENCE

Please respond to the following questions whether or not you have been involved in a collision as a motor vehicle operator. **Please report all collisions whether they were reported to the police.** All answers are completely anonymous.

28. How many collisions have you been in since you passed your driver's exam?
- a. None
 - b. 1
 - c. 2
 - d. 3
 - e. 4
 - f. 5
 - g. 6
29. How many months after you passed your driver's exam did you have your first collision?
- a. Not applicable
 - b. 0-2 months
 - c. 2-4 months
 - d. 4-6 months
 - e. 6-8 months
 - f. 8-10 months
 - g. 10 months or more
30. Have you had a collision with a fixed object? (Parked car, guard rail, sign, tree, etc.)
- a. Yes
 - b. No
31. Have you had a collision with another moving motor vehicle?
- a. Yes
 - b. No
32. Have you had a collision where personal injury or death was a result?
- a. Yes
 - b. No
33. Have you had a collision where only property damage was involved?
- a. Yes
 - b. No

PART V

If you have not been involved in a collision as a driver, you do not complete Part V. If you have been involved in a collision as a driver, please use response numbers 34-51 for the first collision. Use responses 52-69 for the second collision, and 70-87 for the third collision.

34. Where did the collision happen?
- a. At an intersection
 - b. In between intersections
 - c. Driveway
 - d. Parking lot
 - e. Interchange
 - f. Open highway
 - g. Other
35. What type of roadway?
- a. Straight-level
 - b. Straight-uphill
 - c. Straight-downhill
 - d. Curve-level
 - e. Curve-uphill
 - f. Curve-downhill
 - g. Curve-hilltop
36. Condition of road surface?
- a. Dry
 - b. Wet
 - c. Snow-packed
 - d. Icy
 - e. Gravel
 - f. Loose material on roadway
 - g. Oily
37. When did the collision happen?
- a. 7AM-10AM
 - b. 10AM-1PM
 - c. 1PM-4PM
 - d. 4PM-7PM
 - e. 7PM-10PM
 - f. 10PM-1AM
 - g. 1AM or later

38. What was the visibility at the time of the collision?

- a. Sunrise/sunset
- b. Daytime
- c. Nighttime

39. What was the weather at the time of the collision?

- a. Dry
- b. Rain
- c. Snow
- d. Fog
- e. Sleet
- f. Other

40. What other object was involved?

- a. Another moving car
- b. Truck or bus
- c. Parked vehicle or fixed object
- d. Pedestrian or bicycle
- e. Motorcycle
- f. RR train
- g. Other

41. How did the collision take place?

- a. Struck other vehicle in rear
- b. Other vehicle struck you in rear
- c. Struck other vehicle in side
- d. Other vehicle struck you in side
- e. Head on
- f. Sideswipe
- g. Other

42. What maneuver were you making?

- a. Going straight
- b. Turning
- c. Lane changing
- d. Passing
- e. Merging
- f. Backing
- g. Parking

43. What maneuver was the other driver making? (Leave blank if no other driver)

- a. Going straight
- b. Turning
- c. Lane changing
- d. Passing
- e. Merging
- f. Backing
- g. Parking

44. How did you try to avoid the collision?

- a. Hard brake
- b. Pumped brakes
- c. Quick steering
- d. Steer and brake
- e. Increased speed
- f. Other

45. What mistakes did the other driver make, if any?

- a. None
- b. Speed too fast
- c. Failed to yield
- d. Followed too closely
- e. Misjudged distance or space need
- f. Did not see signs or signals
- g. Did not see me

46. What mistakes did you make, if any?

- a. None
- b. Speed too fast
- c. Failed to yield
- d. Followed too closely
- e. Misjudged distance or space need
- f. Did not see signs or signals
- g. Did not see me

47. Was the accident reported to the Pennsylvania Department of Transportation?

- a. Yes
- b. No

48. Was the accident reported to the police?

- a. Yes
- b. No

49. Was personal injury or death involved?

- a. Yes
- b. No

50. How much damage to property and/or vehicles was done?

- a. Up to \$500
- b. \$501 to \$1,000
- c. \$1,001 to \$1,500
- d. \$1,501 to \$2,000
- e. \$2,001 to \$2,500
- f. \$2,501 to \$3,000

51. Were you wearing your safety belt at the time of the collision?

- a. Yes
- b. No

52. Where did the collision happen?

- a. At an intersection
- b. In between intersections
- c. Driveway
- d. Parking lot
- e. Interchange
- f. Open highway
- g. Other

53. What type of roadway?

- a. Straight-level
- b. Straight-uphill
- c. Straight-downhill
- d. Curve-level
- e. Curve-uphill
- f. Curve-downhill
- g. Curve-hilltop

54. Condition of road surface?

- a. Dry
- b. Wet
- c. Snow-packed
- d. Icy
- e. Gravel
- f. Loose material on roadway
- g. Oily

55. When did the collision happen?
- a. 7AM-10AM
 - b. 10AM-1PM
 - c. 1PM-4PM
 - d. 4PM-7PM
 - e. 7PM-10PM
 - f. 10PM-1AM
 - g. 1AM or later
56. What was the visibility at the time of the collision?
- a. Sunrise/sunset
 - b. Daytime
 - c. Nighttime
57. What was the weather at the time of the collision?
- a. Dry
 - b. Rain
 - c. Snow
 - d. Fog
 - e. Sleet
 - f. Other
58. What other object was involved?
- a. Another moving car
 - b. Truck or bus
 - c. Parked vehicle or fixed object
 - d. Pedestrian or bicycle
 - e. Motorcycle
 - f. RR train
 - g. Other
59. How did the collision take place?
- a. Struck other vehicle in rear
 - b. Other vehicle struck you in rear
 - c. Struck other vehicle in side
 - d. Other vehicle struck you in side
 - e. Head on
 - f. Sideswipe
 - g. Other

60. What maneuver were you making?

- a. Going straight
- b. Turning
- c. Lane changing
- d. Passing
- e. Merging
- f. Backing
- g. Parking

61. What maneuver was the other driver making? (Leave blank if no other driver)

- a. Going straight
- b. Turning
- c. Lane changing
- d. Passing
- e. Merging
- f. Backing
- g. Parking

62. How did you try to avoid the collision?

- a. Hard brake
- b. Pumped brakes
- c. Quick steering
- d. Steer and brake
- e. Increased speed
- f. Other

63. What mistakes did the other driver make, if any?

- a. None
- b. Speed too fast
- c. Failed to yield
- d. Followed too closely
- e. Misjudged distance or space need
- f. Did not see signs or signals
- g. Did not see me

64. What mistakes did you make, if any?

- a. None
- b. Speed too fast
- c. Failed to yield
- d. Followed too closely
- e. Misjudged distance or space need
- f. Did not see signs or signals
- g. Did not see me

65. Was the accident reported to the Pennsylvania Department of Transportation?
- a. Yes
 - b. No
66. Was the accident reported to the police?
- a. Yes
 - b. No
67. Was personal injury or death involved?
- a. Yes
 - b. No
68. How much damage to property and/or vehicles was done?
- a. Up to \$500
 - b. \$501 to \$1,000
 - c. \$1,001 to \$1,500
 - d. \$1,501 to \$2,000
 - e. \$2,001 to \$2,500
 - f. \$2,501 to \$3,000
69. Were you wearing your safety belt at the time of the collision?
- a. Yes
 - b. No
70. Where did the collision happen?
- a. At an intersection
 - b. In between intersections
 - c. Driveway
 - d. Parking lot
 - e. Interchange
 - f. Open highway
 - g. Other
71. What type of roadway?
- a. Straight-level
 - b. Straight-uphill
 - c. Straight-downhill
 - d. Curve-level
 - e. Curve-uphill
 - f. Curve-downhill
 - g. Curve-hilltop

72. Condition of road surface?

- a. Dry
- b. Wet
- c. Snow-packed
- d. Icy
- e. Gravel
- f. Loose material on roadway
- g. Oily

73. When did the collision happen?

- a. 7AM-10AM
- b. 10AM-1PM
- c. 1PM-4PM
- d. 4PM-7PM
- e. 7PM-10PM
- f. 10PM-1AM
- g. 1AM or later

74. What was the visibility at the time of the collision?

- a. Sunrise/sunset
- b. Daytime
- c. Nighttime

75. What was the weather at the time of the collision?

- a. Dry
- b. Rain
- c. Snow
- d. Fog
- e. Sleet
- f. Other

76. What other object was involved?

- a. Another moving car
- b. Truck or bus
- c. Parked vehicle or fixed object
- d. Pedestrian or bicycle
- e. Motorcycle
- f. RR train
- g. Other

77. How did the collision take place?

- a. Struck other vehicle in rear
- b. Other vehicle struck you in rear
- c. Struck other vehicle in side
- d. Other vehicle struck you in side
- e. Head on
- f. Sideswipe
- g. Other

78. What maneuver were you making?

- a. Going straight
- b. Turning
- c. Lane changing
- d. Passing
- e. Merging
- f. Backing
- g. Parking

79. What maneuver was the other driver making? (Leave blank if no other driver)

- a. Going straight
- b. Turning
- c. Lane changing
- d. Passing
- e. Merging
- f. Backing
- g. Parking

80. How did you try to avoid the collision?

- a. Hard brake
- b. Pumped brakes
- c. Quick steering
- d. Steer and brake
- e. Increased speed
- f. Other

81. What mistakes did the other driver make, if any?

- a. None
- b. Speed too fast
- c. Failed to yield
- d. Followed too closely
- e. Misjudged distance or space need
- f. Did not see signs or signals
- g. Did not see me

82. What mistakes did you make, if any?

- a. None
- b. Speed too fast
- c. Failed to yield
- d. Followed too closely
- e. Misjudged distance or space need
- f. Did not see signs or signals
- g. Did not see me

83. Was the accident reported to the Pennsylvania Department of Transportation?

- a. Yes
- b. No

84. Was the accident reported to the police?

- a. Yes
- b. No

85. Was personal injury or death involved?

- a. Yes
- b. No

86. How much damage to property and/or vehicles was done?

- a. Up to \$500
- b. \$501 to \$1,000
- c. \$1,001 to \$1,500
- d. \$1,501 to \$2,000
- e. \$2,001 to \$2,500
- f. \$2,501 to \$3,000

87. Were you wearing your safety belt at the time of the collision?

- a. Yes
- b. No

Appendix C: Teaching Students with Disabilities

Pennsylvania Permit Requirements/Licensing Issues

Program Structure – General Considerations

Adaptive Driving Equipment Vendors and Driver Education/Training Facilities

Introduction

Driver Education is a course that most students look forward to with eager anticipation. This is certainly true for a person with a disability. Driving provides freedom of mobility that everyone cherishes and is virtually indispensable in today's society.

You, the driver education instructor, will be the first source of information regarding obtaining a license for a person with a disability. Many times, the student and parents may not know what types of adaptive driving equipment are available. They may not even know if driving will be possible!

The purpose of this section of the curriculum guide is to aid the instructor in developing a plan to actively involve the student(s) with disabilities in the program. This plan may require special content methods, materials, and adaptive driving equipment.

Students with disabilities are eligible to actively participate in driver education¹ if they meet the licensing requirements established by the Pennsylvania Department of Transportation². P.L. 94-142 requires that a "free appropriate public education" be provided for eligible students in the least restrictive environment. "Appropriate" refers to the unique needs of the individual. "Least restrictive environment" can depend on student needs. The important thing is that students with disabilities be integrated into the regular class when possible. The driver education instructor has a professional responsibility to determine the best course of action to take.

A student's success or failure depends largely on the instructor's ability to design effective strategies that will build on the person's capabilities. An individualized educational plan (IEP) should allow the student to attain the same performance objectives as any other student enrolled in driver education.

To that end, it is vitally important to consult with as many people as possible. Counselors, special education instructors, doctors, psychologists, and occupational and physical therapists have an area of expertise that will prove invaluable in helping develop your plan.

¹ P.L. 94-142 and Section 504 of P.L. 93-112, The Rehabilitation Act of 1973

² Pennsylvania Driver's Manual, pp. 1-2, 1999

Pennsylvania Physical Requirements/Licensing Issues

The *Physical Examination Form* (DL-180) is the PENNDOT form that must be completed prior to a person obtaining a Learner's permit. Pertinent information for the driver education instructor to know includes:

- If the physician checks any of the ten questions "yes", the student will NOT receive the permit at the exam site. When the student passes the vision and knowledge tests, the local PENNDOT examiner will send all the forms to the Medical Qualifications Section at PENNDOT. A person in the Medical Qualifications Section will determine what type of permit the student will need and will send it directly to them. The two types of permits are:
 - Regular permit-Same type issued to all new drivers
 - Dual Control permit- Requires that the driver practice ONLY in a dual control equipped vehicle (driver training car)

Example: A student has had their right leg amputated. The doctor checks box number 9, "Immobility or Amputation of an Appendage?" "yes". PENNDOT may issue a Dual Control permit to allow the student to practice in a driver training car equipped with a left foot accelerator.

Example: Your student using a wheelchair obtains a Dual Control permit and the driver training car is equipped with hand controls and a spinner knob. The student can complete training and testing in that vehicle with the instructor. The letter would indicate testing with hand controls, spinner knob, and parking brake extension (if needed). The needed medical restrictions would be 3 - Equip with automatic shift, 4- Special equipment (hand controls for acceleration and braking, spinner knob for steering, and parking brake extension).

Specific questions regarding permits should be addressed to:

PENNDOT Medical Unit
Harrisburg, PA. (717) 705-7604

The following are some common examples of disabilities, the proper adaptive equipment, and the necessary coding for the Pennsylvania license:

Disability	Adaptive Equipment	Medical Restrictions
Wheelchair user	Hand controls, spinner knob, parking brake extension	3 -Equip with automatic shift 4- Special equipment- (list)
Right leg amputee	Left foot accelerator	3- Equip with automatic shift 4-Special equipment- (list)
Hearing impaired/deaf	Dual outside mirrors	2 -Equip with outside mirrors
Dwarfism	Pedal extensions and cushions	4 -Special equipment

- A person must be seizure free for a minimum of six (6) months prior to applying for a permit or qualify for a waiver. (contact PENNDOT for details regarding waiver)
- If someone has less than 20/40 corrected visual acuity, they will be required to have an eye exam by an Optometrist or Ophthalmologist prior to obtaining a permit the eye specialist must complete the PENNDOT form- DL-102, Report of Eye Examination. The person must take the DL-102 along back to the exam center when next applying for the permit.
- If a student has trouble reading, they can request the "audio permit test" at the PENNDOT Exam Center. Using a pair of headphones, the student can listen to the questions being read while also being able to read them on the computer screen. This test is also different from the regular test in that it is true/false rather than multiple choice.
- If the exam center does not have the computer test, the student can request the test be read orally and an examiner will make that accommodation.
- Hearing impaired or deaf persons can either bring an interpreter or PENNDOT will provide one for them. Please refer to the Pennsylvania Driver's Manual for instructions.

Program Structure - General Considerations

Classroom

- Students with physical disabilities must be provided a classroom environment that allows them to interact with discussion. This usually means sitting somewhere close to the front of the room and having a desk high enough to comfortably get the wheelchair under.
- Deaf students should be seated to the front and side to allow enough room for the interpreter to see both the instructor and student.
- Students with learning disabilities could be given smaller amounts of information and allowed additional time to complete assignments. Consult with the special education teacher for additional strategies.
- Include all students in class discussion! The "Stop, Think, and Go" and Perceptual Driving Programs are ideal for class participation, so do not let any student out.

Behind-The-Wheel/Range

- Acquire basic adaptive equipment (see following pages) and become completely familiar with it. In order for you to be an effective teacher, you must know how the equipment works.
- Take as much time as needed on off-street area to get the student familiar with the controls. Everyone should be able to make smooth starts, stops, left and right turns prior to proceeding to residential driving.
- Try to schedule behind-the-wheel lessons to allow disabled and non-disabled students to drive with each other. The observation time will be valuable for all students.
- Actively involve ALL backseat observers.
- Use an interpreter with deaf students. After introducing the lesson, have the interpreter sit directly behind you. If a problem arises on the road, have the student pull over for immediate feedback. Use the interpreter again for the lesson conclusion.
- Learn the basic sign language for left and right turns, stop, accelerate, slow down, and check the mirrors. Make sure to go over the signs with the student(s) before getting into the car.
- Use performance checklists to document student progress as well as a daily log.

Simulation

- Equip one simulator with hand controls and spinner knob for use by a student in a wheelchair.
- Keep a transfer board in simulation lab for use when needed.
- Position deaf student in simulator to allow room for interpreter, but not to interfere with other students' line-of-sight. Simulation laser discs are available with captioning, but it is advised to NOT use the captioning. Most captioning is done in English, but most deaf students learn American Sign Language (ASL) first. The English captioning is too wordy, and most students cannot read it quickly enough. The interpreter can be used to

interpret what that narrator says while the student watches the screen. You will also need the interpreter anytime you pause the program to ask questions or make comments.

- Simulation can be a very valuable tool for someone with a learning disability because it is visual and hands-on.

Cost and Acquisition of Equipment

- The easiest and best way to acquire basic adaptive driving equipment is through donation by a mobility equipment vendor. Talk to a vendor and ask if they would donate the equipment to the school. This is great for public relations, particularly if the vendor is within the school district. It is a win-win situation for both parties because you get the equipment to teach your student and the vendor gets some advertisement.
- General Motors, Ford, Dodge, Saturn, and Subaru have "Mobility Programs" that pay for adaptive equipment that is installed in a new vehicle. Reimbursement ranges from \$500 - \$1000.
- Make a presentation to your school's Board of Education showing the need for this type of equipment. There is no more liability with using hand controls than foot pedals. This equipment is relatively inexpensive and can be used a long time. Equipment can also be transferred when a new driver training vehicle is obtained.

Approximate Cost of Basic Equipment (installed)

Equipment	Cost
Hand Controls	\$700
Spinner knob steering device (quick release)	\$75
Left foot accelerator (quick release w/OEM gas pedal block)	\$300
Chest strap (upper body stability)	\$100
Transfer board	Make in Woodshop class

Hand Controls-This is a mechanical device that allows a person to operate the foot pedals (gas and brake) by one hand. There are several different types including: push/pull, push/twist, push/right angle, and push/rotary. The most common is push/right angle. It is very important to remember that having hand controls on the car does not render it unable to be driven to able-bodied students. There is no alteration to the factory pedals.

Spinner Knob -This allows a person using hand controls to safely steer the vehicle with one hand. It has a bracket that clamps to the steering wheel where most appropriate and safe. The knob spins freely and can be removed with the push of a button. This should be taken off for able-bodied drivers.

Left foot accelerator- This allows control of the accelerator with the left foot. This is used for persons who have lost partial or complete use of the right leg and/or foot. The quick release

type has a bracket that mounts to the floor and the pedal clamps into it. This allows it to be removed when not needed. There should also be a "block-off plate" that prevents accidental pushing on the O.E.M. gas pedal.

Chest strap - This is for the individual who does not have adequate upper body stability. If a person slumps over when making a turn, they need a chest strap. This is NOT an occupant restraint.

Transfer board -This can make it easier for a person to transfer from their wheelchair into the car. The board is placed on the edge of the car seat and the wheelchair and the person slides across. It is usually made out of wood or plastic.

Adaptive Driving Equipment Vendors and Driver Education/Training Facilities

For a complete list of adaptive driver education equipment vendors and driver education/training facilities, please contact the Pennsylvania Office Of Vocational Rehabilitation.

Module II - Decision Making Process

Introduction

Driving is much more than a mechanical process of steering and braking. Many young, inexperienced drivers view it as a purely manual activity requiring little more than good

hand-eye coordination and fast reflexes. Driver education students who fail to recognize and understand the risk factors that impact driving are also powerless to manage these same risk factors.

The ultimate goal of driver education programs must be to teach young people to be safe and responsible drivers. This goal can be achieved through information dissemination, skill training, and decision-making. Driver education programs have been successful in teaching students what they need to know about safe driving. These same programs have likewise been successful in teaching students safe and responsible motor vehicle handling skills. Still, the incidence of unintentional injury and death experienced by young drivers remains very high. The primary causes for high injury and mortality rates are driving inexperience and driver inability to manage risk.

Few vehicle crashes occur during on-the-road training because driver education teachers, sitting in the passenger seat, have used their risk management skills to keep their students safe. However, this will not always be the case. Eventually, these students will be on their own and will no longer be able to rely on the good judgment of their instructors. While this will be so, driver education instructors can provide their students with something other than their presence that will help to keep them safe. Driver education teachers can provide their students with the ability to become effective risk managers.

In the pages that follow, you will be presented with an easy to use and effective three step decision-making model that is every bit as critical to driver safety as wearing seatbelts. Using the STOP -THINK & GO Decision-Making Process, your students will learn how to take control of their driving options rather than be controlled by their environment. No longer will they be forced to react to driving situations when they could decide. Give your students something on which they can rely in your absence, their own good judgment.

Learn about the value of the STOP- THINK & GO Decision-Making Process and teach your students:

- the purpose of decision-making and its positive impact on highway safety;
- how to recognize and reduce the four driving errors that are responsible for most vehicle crashes; and
- how to make effective STOP - THINK & GO decisions.

This unit will provide you with invaluable information on STOP - THINK & GO Decision Making. You will learn how to teach it, be given applications for its use in and outside the classroom; and

will be introduced to a range of activities that will help your students to connect with the purpose, process, and practice of decision-making as it relates to driving.

The remaining units in this unique and practical driver education program emphasize the importance of decision-making and risk management. This program demonstrates the use of decision-making in all facets of driving and requires students to demonstrate their risk management capabilities throughout this course of study. Help your students to understand that it is not how much they know that counts, but rather counting on what they know to make effective, safe, and responsible driving decisions.

STOP - THINK & GO DECISION-MAKING PROCESS

"A Matter of Driver & Traffic Safety"

Driving is a life changing experience. For some young people, it will provide them with independence and opportunity while others will face bodily injury and death. What many teenage drivers don't understand is that despite the advantages of driving, motor vehicle crashes are the leading cause of death for their age group (16 to 19 years). The crash rates per mile driven are highest for 16-year-olds, the age when most beginning drivers obtain their licenses.

The National Highway Traffic Safety Administration and the US Department of Transportation believe that the high incidence of vehicular crashes among teenagers is largely due to driver immaturity and driving inexperience. This deadly combination of deficits accounts for such risky driving behaviors as tailgating, speeding, and driver difficulty in recognizing and responding to roadway hazards and dangers. Consequently, teenage drivers find themselves in difficulty when responding to routine and changing driving situations which require them to be effective risk managers. Indeed, most crashes involving young drivers can be related to driving error and the absence of responsible decision-making.

Since driving is a hazardous activity with the potential for causing death, bodily injury, and property damage, drivers must be prepared to make responsible driving decisions that will enhance human safety. Driving is both a mental and physical activity. Teaching young drivers vehicle handling skills in the absence of teaching them effective and responsible decision-making is to suggest that driving is purely a robotic activity completely devoid of logic and reason. Successful and responsible teenage drivers understand the purpose, process, and practice of decision-making. Decision-making is a critical factor in helping young drivers to counter the effects of driver immaturity and driving inexperience, the two leading causes of vehicular crashes, death, and disability in this population.

Purpose

The purpose of teaching young driver's decision-making is to improve driver safety and to reduce the incidents of loss that occur when risk management practices are ignored or improperly used. The ability to make decisions intelligently, without procrastinating or vacillating, is a vital driving and life process.

As with any process, decision-making must be taught and practiced if it is to be used effectively. To recognize decision-making as a central condition of driving and then fail to integrate this process into every dimension of driver education is to negate its importance as a life-saving tool.

Young drivers, who are not challenged to apply newly acquired information, skills, and attitudes to driving situations, may fail to see the importance of these teachings and therefore may not use them. They will not develop logic and information-processing skills needed to make safe driving decisions in fluid environments. Young drivers must understand that it is not how much they know that counts, but rather counting on what they know to make effective driving decisions based on solid risk assessment and risk management strategies.

In order for decision-making to be accepted as a necessary and viable process in helping young drivers to get from where they are to where they want to be safely, they must truly believe in and experience its value. If young people are to develop a positive attitude toward decision-making and its impact on safe driving, they will need to be exposed to accurate information regarding its use and participate in perception changing experiences that will amplify its virtues.

With a positive change in attitude toward decision-making, driver education instructors will increase the likelihood that the practice of decision-making will follow. The *Activities* section of this unit provides classroom experiences that demonstrate the value of decision-making.

Driver education instructors can help young drivers to develop a positive appreciation for decision-making. They can help them to understand that most vehicular crashes involving their age group occur because of driver limitations and human error, both of which can be reduced through effective decision-making. They also must learn that most poor decisions are not the fault of the process, but rather lie with the decision-maker's failure to use the process correctly.

Rather than have young drivers attack decision-making as an impractical process, driver education instructors can help them to become more effective users of it. What follows is a brief discussion of driver limitations and human errors that result in unsafe driving practices, injury, and death and the value of decision-making in reducing these limitations and errors?

Driver Limitations

Learning to make effective driving decisions is contingent upon helping young people to understand how they limit their driving options in the absence of decision-making. What follows is an explanation of three ways in which young drivers compromise their driving safety without knowing it.

1. Decisions are limited by a driver's capabilities.

Safe driving is contingent upon driver ability to perform safe driving actions. Young drivers, lacking in driving information, skills, self-confidence, and practical experience, are limited in their ability to make safe driving decisions. For example, young drivers lacking in perceptual skill training are not likely to consider traffic controls, highway conditions, and other roadway user clues when executing driving actions. When young drivers increase their driving capabilities through education and training and learn how to

apply what they have learned, their decision-making skills will improve. When this happens, driver safety will also improve.

2. Decisions are limited by the environment.

Safe drivers are aware of and use environmental information to make safe driving decisions. They observe a traffic control sign, derive information from it, and use that information in executing a safe driving decision. However, many drivers fail to observe traffic controls or if they see them, they do not derive meaning from them in making safe driving decisions. These drivers are called responders or reactors. They respond/react to environmental conditions. A responder will see a stop sign but will not derive information from it. Rather, this person will slam on the brakes, skid into the intersection, and then blame the vehicle or the placement of the stop sign for loss of control.

Driver safety will improve when drivers recognize that they are not the victims of their environment. They can derive meaningful information from their environment and use it to make safe and responsible driving decisions. Decision-makers, in contrast to responders, are skillful in identifying and using traffic controls, highway conditions, and other roadway user clues in assessing their driving options before taking action.

3. Decisions are limited by what a driver is willing to do.

Safe driving is contingent upon drivers practicing safe driving habits and using effective decision-making strategies. However, human nature being what it is, people tend to gravitate toward their comfort zone. They resist change. Unless young drivers are open to change and are willing to do so, they will exit the driving experience as they entered it, unchanged.

Young drivers are more likely to be safe and responsible drivers to the extent that they are willing to apply what they have learned about driving to the driving experience. The same can be said about decision-making. Decision-making is more likely to be used if young drivers get into the habit of using it. For this to happen, driver education instructors must teach decision-making and then require its use in all driving related situations. In the final analysis, young drivers will determine if they are willing to use decision-making in guiding their driving actions and we hope they will.

Human Errors

Human error is a major factor in vehicular crashes. Many of these errors can be significantly reduced to the extent that the three previous limitations can be delimited. When young drivers develop their driving capabilities, learn to become successful decision-makers rather than responders, and are willing to put into practice what they have learned, they will dramatically increase their chances for a safe driving experience.

The following four human errors are the cause of most vehicular crashes. Reduce the incidence of these errors, and the number of vehicular crashes, injuries, and deaths will decline.

Error 1: Not choosing an action because one does not know it as a possibility.

Responders commit this type of error. They react in response to environmental cues. Responders fail to consider their options, because they execute the first response that enters their head. For example, a responder is likely to miss or ignore traffic controls or highway conditions until they are confronted with danger and then react. Responders will brake in the midst of a curve while decision-makers, using environmental data, are prepared for the curve and will decrease their speed well in advance of it. Responders tend to be more erratic drivers than decision-makers because they make impulsive driving adjustments, on limited data, in the immediacy of the moment. Decision-makers consider many options before taking action and therefore are less prone to committing a Type 1 Error.

Error 2: Choosing an action even though one does not know the possible outcomes.

Responders rarely consider the possible outcomes of their actions. They tend to rely on a gambler's mentality and blind faith (wishful thinking) that everything they do will work out in their favor. Acting without thinking about the consequences is an inherent aspect of respondent conditioning.

Type 2 Errors can be reduced when young drivers view driving as a mental activity that requires their full and undivided attention. Only when drivers engage in decision-making do they identify, evaluate, and judge the potential consequences of their choices before acting.

Error 3: Underestimating or overestimating the importance of certain information.

Using information effectively and responsibly is required of safe and responsible drivers. Many vehicular crashes occur because drivers fail to conduct a reality check on the information (beliefs, attitudes and skills) which they are using in a driving situation.

Underestimating or overestimating the importance of information can place drivers, passengers, and other roadway users at risk of injury or death. For example, some drivers fail to wear seat belts, because they personally underestimate the information which speaks to their protective value. Other drivers may overestimate the value of seat belt information and drive recklessly, because they believe that seat belts will fully protect them from injury in all driving situations.

Valid and reliable information is required to make safe and responsible driving decisions. Drivers who rely on inaccurate information or who underestimate or overestimate the value of information they receive are placing themselves and others at risk. When drivers learn to conduct reality checks on the information that supports their driving options, they will be less likely to commit a Type 3 Error.

Error 4: Relying on myths or assumptions in choosing an action.

When young drivers commit a Type 4 Error, they are relying on rumors, myths, and assumptions as the basis for their actions. Cognitive distortions and faulty beliefs run counter to

reason, often with dire consequences. For example, young drivers may believe that all motorists stop at STOP signs, vehicle engines that start must be mechanically sound and that most vehicular crashes occur far away from home. Armed with these thoughts, young drivers are likely to engage in dangerous driving behaviors.

Similar faulty reasoning occurs when young drivers accept the myth that appearance is a valid proof of reality. In doing so, they allow themselves to be taken advantage of by con artists selling used cars at low prices, picking up friendly looking hitch hikers, and accepting rides from people who have been consuming alcohol, but who appear sober. When young people are taught how to recognize and challenge the myths and assumptions that compromise their ability to reason in the face of danger, they will reduce their vulnerability to Type 4 Errors.

Process

In order to understand decision-making and its significance in helping young people to become safe and responsible drivers, some insight into the driving experience is necessary. Driving, by its very nature, is a hazardous activity. A hazard refers to any condition or experience that has the potential for causing injury, death, or property damage. Consequently, many life experiences can be defined as potentially hazardous including riding in a motor vehicle and walking along a roadway.

When people interact with a hazardous condition they expose themselves to harm. Exposure to harm, regardless of the degree, implies danger. Therefore, people who drive or ride in motor vehicles are in danger of being harmed.

While operating a motor vehicle is a hazardous activity, no two people who drive are exposed to the same degree of danger (harm). The variability of danger to which drivers are exposed is known as risk. Drivers can manage the degree of risk to which they are exposed if they are aware of it, are able to assess it, and then are able to personally judge for themselves how they will address it. This process is known as risk management and commonly referred to as decision-making.

When faced with a known risk, drivers have five options they can implement to increase their safety:

1. **Risk Avoidance.** When the potential for personal risk to life and property is judged to be excessive, an individual may choose to avoid the risk altogether.
 - a. *Example:* Bob chooses not to ride in motor vehicles with drivers who have been consuming alcohol.
2. **Risk Prevention.** Most driving situations pose a variety of dangers that can be corrected before the driver even gets behind-the-wheel.
 - a. *Example:* Before Bob enters his vehicle, he checks his tires for worn spots, washes his windshield, and checks and replaces worn engine hoses and belts.

3. **Risk Reduction.** While risk prevention actions are applied in advance of being exposed to the risk, risk reduction methods are applied while participating in the risk-taking event.
 - a. *Example:* Susan uses traffic control information that warns her of a sharp curve in the road and she adjusts her speed accordingly (lowers speed).
4. **Risk Protection.** When involved in a hazardous activity that poses physical harm, participants can anticipate that harm and protect their bodies.
 - a. *Example:* Bob and Susan wear seat belts as passengers and drivers in motor vehicles.
5. **Risk Acceptance.** Recognizing that few things in life are perfectly safe, people have to judge the level of risk (harm) which they are willing to accept. This decision is made after considering ways in which the risk can be managed.
 - a. *Example:* Bob and Susan choose to accept the risk that driving a motor vehicle presents knowing that they have done what they can to make driving a relatively safe experience.

Decision-making (risk management) is designed to reduce driver limitations and human errors as they relate to the driving experience. What follows is an in-depth discussion of the decision-making process and how to use it effectively and responsibly.

STOP- THINK & GO Decision-Making Process

STOP - THINK (& GO Decision-Making is a risk management process that is designed to help young drivers (Worzbyt, 1989, 1991, 1996)

- increase their **awareness** of risk;
- **measure** risk to themselves, others, and property;
- **judge** whether or not to accept the risk; and
- **act** safely in response to risk.

Recognizing that familiarity, simplicity, and usability are three conditions that enhance learning, the STOP- THINK & GO Decision-Making Process was fashioned after a traffic signal light. Most young people are familiar with traffic signal lights and understand their practical application in helping to insure for the safe flow of vehicular and pedestrian traffic through busy and potentially dangerous intersections. The following three-step Decision-Making Model (figure 2.1) functions like a traffic signal light providing for an element of safety when processing driving options, some of which could be dangerous. The model facilitates the safe flow of helpful driving choices through a systematic process which also identifies and discards potentially harmful driving options. Hence, this safety focused decision-making model becomes a "winning signal" for all people who use it and who are impacted by its use (drivers, passengers, and other roadway users).

The STOP- THINK & GO Decision-Making Process stresses the importance of viewing driving as a goal-oriented, mental process requiring the undivided attention of the driver.

Drivers are first instructed to STOP and clarify (verbalize) their driving goal and problem. In this model, the driving goal is the same for most driving situations: "To reach my destination safely."

The driving problem is related to the goal and is written as a question to be solved: "What must I do to reach my driving destination safely?"

Drivers are then instructed to proceed with caution to THINK of potential risk factors and dangers related to the specific driving situation in question. Risk factors are grouped into four categories. They are (1) human, (2) vehicle safety & performance, (3) highway conditions, and (4) other highway users.

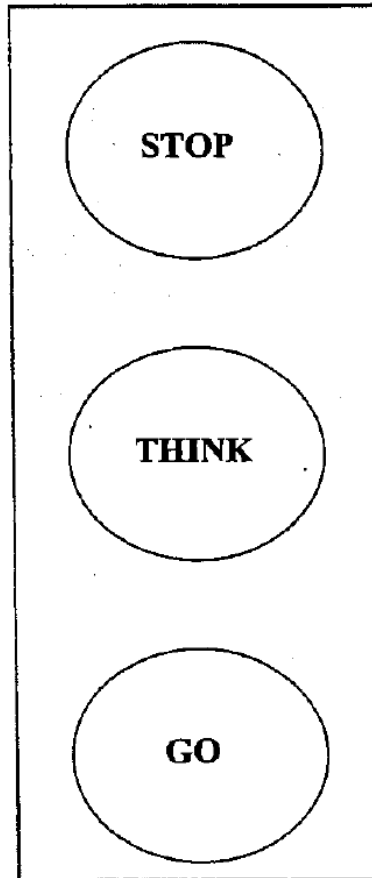

Figure 2.1 STOP - THINK & GO Decision-Making Model

- *Human risk factors* relate to those human conditions which place drivers at increased risk. Factors such as visual acuity, perceptual skills, hearing, physical agility, and mental alertness can be compromised by such factors as aging, illness, use of medications, and other drug and alcohol use.
- *Vehicle risk factors* relate to all those conditions which effect vehicle safety and performance. Equipment failure and misuse and structural limitations place driver, passengers, and other highway users at risk of being harmed.
- *Highway condition risk factors* relate to road surfaces, the availability of space, and visibility. Many highway condition risk factors are identifiable by highway controls such as signs, signals and road markings which are designed to regulate, warn, and guide drivers through roadway hazards.

- *Other roadway user risk factors* relate to those dangers posed by other people who share the same roadway space.

Once the risk factors and dangers have been identified, potential driving choices designed to address those risk factors are listed. Drivers are then instructed how to filter their choices (Right, Reality, & Responsibility), eliminating those from further consideration which could compromise their safety and that of their passengers and other roadway users.

Lastly, drivers are to GO with choice(s) that will help them to achieve their driving goal safely. Driving choices that pass through all three filters (Right, Reality, and Responsibility) are deemed acceptable (safe) choices which will pose minimal risks to those effected by the decision.

Right, Reality, & Responsibility

The three filters of Right, Reality, and Responsibility are key components of the THINK stage of decision-making. They work in the same manner as coffee, fuel, and human body filters. Their purpose is to protect young drivers from implementing harmful driving choices. The filters prevent high risk and dangerous driving choices from being implemented and yet allow for the passage of safe and responsible choices through the decision-making process. Figure 2.2 illustrates how the three filters screen driver choices.

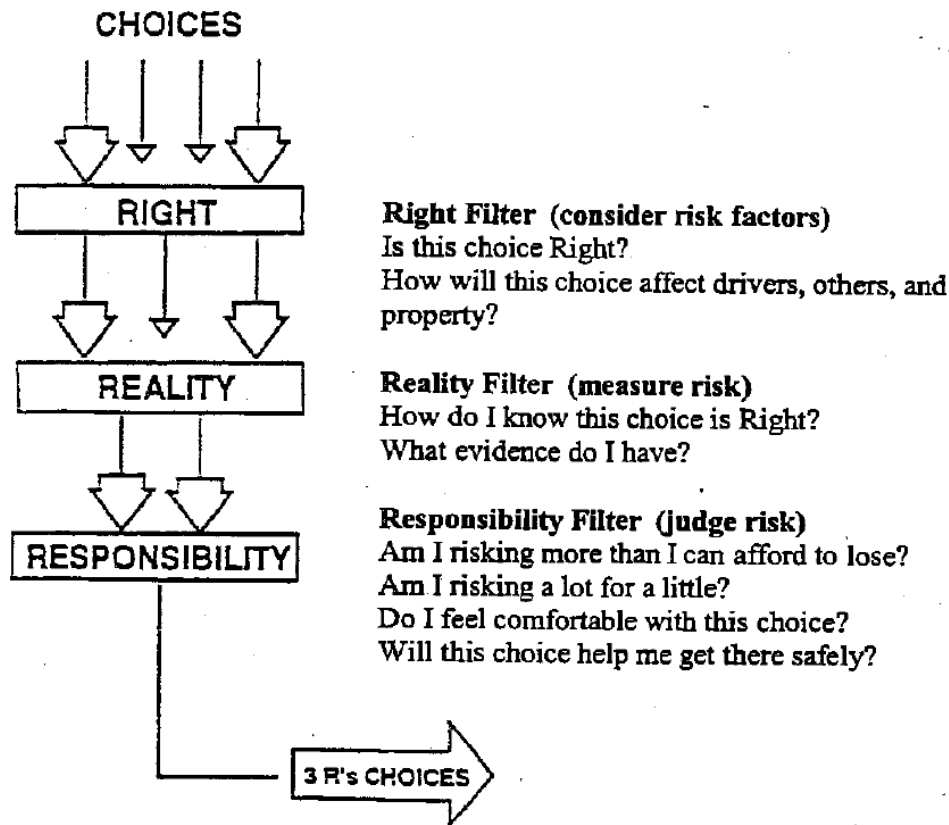

Figure 2.2 Three Filters - Right, Reality and Responsibility

When young drivers are confronted with a driving situation, they are encouraged to seek a 3R's solution. The three filters will help drivers to slow down and review their driving choices in light of the risks they present. High-risk choices are to be avoided and acceptable risk choices are to be managed and implemented with safety in mind (risk protection, risk prevention, and risk reduction).

Right Filter. Drivers are asked to consider the driving risk factors and if the choice is filtered is a *right thing to do* in response to managing those risk factors? Right choices must be legal (based in law), ethical (meet acceptable driving standards) and moral (respectful & courteous). In addition, Right choices must be helpful and not hurtful to drivers, passengers, other roadway users and property. To the extent that a driving choice meets these conditions, it will pass through the Right filter.

Reality Filter. The Reality filter challenges drivers to measure the risk(s) associated with the choice being considered. When measuring risk, drivers are to access valid and reliable information (facts, observational data, statistics, etc.) so they can consider the consequences of this choice and the probability of their occurrence.

While scientists and crash reconstructionist cannot forecast who, when, or what will happen to specific individuals who engage in high-risk driving behaviors, they are able to offer useful predictive data that can assist drivers in drawing valid conclusions about their own driving situation. For example, there is much available and valid data pertaining to the consequences (and probability) of such high-risk behaviors as drinking alcohol and driving, speeding, and tailgating.

A driving choice will pass through the Reality filter if the driver can provide valid and reliable evidence that supports this choice as one that will lead to successful goal attainment with minimal risk to driver, passengers and other roadway users. Choices lacking in valid and reliable evidence will not pass through this filter. Only when drivers do a Reality check on their choices are they capable of assessing their risk.

Responsibility Filter. While measuring risk is an objective scientific process, judging risk is very much a personal and subjective activity. Knowing the consequences and probability of risk still leaves drivers with the responsibility of deciding for themselves if they will accept or avoid the risk(s) associated with the choice being filtered.

While judging risk is a personal responsibility, there are guidelines that drivers can apply in helping them to decide if a particular driving choice and the inherent risks are acceptable or unacceptable to them. The Responsibility filter helps drivers decide if the choice in question is the right thing to do. The Responsibility filter screening guidelines follow (Thygeson, 1992).

- **Am I risking more than I can afford to lose?** With every driving choice, there are risks and the potential for loss. Some losses can be permanent such as loss of life and physical and mental disability while other losses can be difficult from which to recover. The death and injury of friends, loss of a job and/or income, and loss of personal

property can take their toll in human suffering. If the potential for loss is high and the nature of the loss great, drivers may be risking more than they can afford to lose.

- **Am I risking a lot for a little?** If the gains are small and the risks are high, drivers are risking a lot for a little. Drivers who take chances with their lives and the lives of others to save a few minutes of time are risking death and/or permanent disability for everyone affected by their high-risk choice. Drivers must consider the potential gains and losses associated with their choices before acting.
- **Do I feel comfortable with this choice?** Responsible drivers rely on their own intuition and gut feelings when making driving choices. Despite all of the available evidence that says this is a safe and responsible driving choice, a driver who feels uneasy or hesitant to act should reconsider his/her position rather than go against internal data to the contrary. Safe and responsible drivers listen to their head and heart.
- **Will this choice help me get there safely?** The ultimate test of a responsible choice is that it will help the driver get from where he/she is to where he/she wants to be safely without putting passengers and other highway users at risk of injury or death.

Any driving choice which is judged by the driver to be too risky is not a responsible choice and should be avoided. The three filters of Right, Reality, and Responsibility teach young drivers that driving is a mental activity and that risk management and safety can only be attained through reason followed by action.

With practice, the STOP- THINK & GO Decision-Making Process will become a habit. Young drivers will be able to execute the process accurately and quickly with safe, reliable, and responsible results. Young drivers who learn to make STOP- THINK & GO Decision-Making Process driving decisions will:

- regard driving and traffic safety from a decision-making perspective;
- view driving as a mental and physical activity;
- initiate safe and responsible driving practices;
- exhibit more control and less confusion in unfamiliar driving situations; and
- create a safe driving environment for themselves and others because they are effective risk managers.

In contrast to the benefits shared by drivers who use the STOP - THINK & GO Decision- Making Process are the pitfalls that are experienced by those people who fail to recognize and apply decision-making while driving. These people are likely to become drivers who:

- rely more heavily on their reflexes than reason;
- view driving as a purely mechanical process;
- are the casualties of driving errors;
- experience confusion and behave irresponsibly when confronted with unfamiliar and complex driving situations; and
- take unnecessary chances and engage in high-risk behaviors.

Practice

The STOP- THINK & GO Decision-Making Process provides young drivers with an opportunity to apply, in classroom settings and behind-the-wheel training, what they know and understand about safe and responsible driving. What follows is a case situation (figure 2.3) and discussion of how to implement the STOP- THINK & GO Decision-Making Process using the worksheet in figure 2.4.

A Driving Dilemma

You are in your motor vehicle (standard brakes) descending down a moderate grade, snow covered, two-lane secondary road. A single vehicle is following you at approximately one car length. There are no additional vehicles in site. The posted speed for this stretch of road is 35 mph. As you round a curve in the road, you see a STOP sign approximately 300 feet in front of you.

Figure 2.3 A Driving Dilemma

After reading and briefly discussing "A Driving Dilemma", students are to process the case study through the STOP- THINK & GO Decision-Making Process Worksheet (figure 2.4) in search of a safe conclusion to this driving situation.

Decision-Making Worksheet

STOP

- A. State driving goal:
- B. State driving problem:

THINK

- A. Identify potential risk factors and dangers:
- B. Identify driving choices (address risk factors and dangers):
 - a. Choice:
 - b. Choice:
- C. Filter your choices:
 - a. **Right Filter** (Consider Risk Factors)
 - i. Is this choice right (legal, ethical, and moral)?
 - ii. How will this choice affect the drivers, others, and property?
 - b. **Reality Filter** (Measure Risk)
 - i. How do I know this choice is Right?
 - ii. What evidence do I have?

- c. **Responsibility Filter (Judge Risk)**
 - i. Am I risking more than I can afford to lose?
 - ii. Am I risking a lot for a little?
 - iii. Do I feel comfortable with this choice?
 - iv. Will this choice help me get there safely?

GO

- A. State your selected driving choices:
- B. Explain how this action will meet your driving goal.

Figure 2.4 Stop-Think & Go Decision-Making Process Worksheet

Processing the Dilemma

STOP. The first step that students must take after discussing the particular of this case situation is to STOP and state the driver's goal and problem. In this case situation, as is true for most driving challenges, the driver's goal is, "To get from where I am to where I want to be safely". This goal statement also assumes responsibility for the safety of one's passengers and other highway users.

The driver's problem is always the flip side of the goal and is stated as a question to be answered. Thus the driver's problem is, "What must I do to get from where I am to where I want to be safely?" Because most driver goal and problem statements can be presented similarly and consistently, young drivers should encounter little difficulty stating their driving goal and problem (question).

THINK. Moving to the second step of decision-making, students are to identify (name) the risk factors and subsequent dangers in the presenting case study (figure 2.3). Awareness of hazards and dangers in driving situations is the key to risk management. The risk factor categories presented earlier in this unit can help students identify potential risks (observable and hidden). These categories are human risk factors, vehicle risk factors, highway condition risk factors, and risk factors associated with other roadway users.

Some specific risk factors and dangers present in A Driving Dilemma (figure 2.3) are as follows:

Risk Factors	Dangers
Snow covered road	Loss of control of vehicle due to poor traction resulting in harm to driver, vehicle and other roadway users.
Moderate road grade	Loss of control due to increased speed going downhill coupled with poor traction. Result: harm to driver, vehicle, and other roadway users.
Curve in road	Loss of control brought on by the previous risk factors and gravitational forces in navigating a curve. Dangers: same as above.

Other presenting risk factors are speed, the space between the two vehicles, and the approaching intersection. Hidden or unknown risk factors are the physical and mental health of both drivers and the operating condition of both vehicles. The more risk factors that a driver can identify and anticipate; the greater the likelihood is that they will be factored into the driver's decision(s) with increased safety as the outcome.

Once the risk factors have been identified, students are to list possible driving choices that can help them to solve their driving problem and achieve their driving goal. The most effective choices will be those that address the presenting risk factors and dangers. The following driving choices represent a range of possibilities open to the driver. These options address one or more of the presenting risk factors in A Driving Dilemma (figure 2.3).

1. Firmly depress the brake until you come to a complete stop at the STOP sign.
2. Flash your brake lights to warn the driver behind you, gradually reduce your speed by squeezing your brakes while monitoring the space behind and in front of you and bring your vehicle to a stop at the STOP sign.
3. Complete all of the steps in choice number 2, and in addition, scan the berm (shoulder) for an escape route should the driver behind you lose control of his/her vehicle and threaten your safety.

Before moving to GO, the third and final step in decision-making, students are to filter their driving choices. The three filters of Right, Reality, and Responsibility will help students to critically evaluate their choices in search of those options that are safe and address the risk factors in question.

The filtering process can be approached in two ways. Students can be asked to filter all of their choices in search of safe and responsible choices or they may select those choices to filter which they believe best address the identified risk factors. The first option, while taking longer, gives students the opportunity to discuss all of their choices, the unsafe and the safe. The second option can be used with students who are very familiar with the STOP - THINK & GO Decision-Making Process and who are able to eliminate most unsafe choices by mentally processing them through the filters. They then have more opportunity and time to process one or two of their most helpful choices. A choice that passes through all three filters increases the odds for a safe conclusion to A Driving Dilemma. For the sake of time and space, choice three will be processed through the three filters. In this choice, you have elected to put on your flashers, reduce speed by squeezing your brakes, monitor space behind and in front of your vehicle, search for an escape route if needed, bring your vehicle to a complete stop at the STOP sign.

Right Filter. Students are to review the risk factors presented in this case and then decide if the third option being discussed is a Right thing to do in managing the listed risk factors. Option 3 will pass through the Right filter if it is deemed to be a legal, ethical, and moral choice and one that will be helpful to the driver and other roadway users in safely managing A Driving Dilemma.

A discussion of Options 3 by students will likely lead them to conclude that it will pass through the Right filter.

Reality Filter. When using the Reality filter, students must provide evidence (facts, statistical data, observational information, etc.) and/or logic that support Option 3 as a *Right thing to do*. Where is the evidence that says Option 3 will successfully manage the driving risks and dangers presented in *A Driving Dilemma*? Students should be asked to provide data and/or logic supporting the use of flashers to warn the following driver, squeezing the brakes, monitoring space around the vehicle, and searching for an escape route should it be needed? These actions should be examined in the context of reducing the dangers identified in the case study.

The Reality filter requires students to identify and use what they have learned about safe driving and apply that information in assessing the Rightness of their driving options (choices). In reviewing Option 3, data and logic can be provided to support the actions stated as a way of addressing the identified risk factors (following car, snow, road curves, speed, traction, visibility, etc.) in this case study. Option 3 will thus pass through the Reality filter.

Responsibility Filter. Before committing Option 3 to action, students must judge for themselves if they feel comfortable with their choice. The ultimate goal is to implement a course of action that will result in a safe conclusion to *A Driving Dilemma*. Drivers must decide for themselves if the potential risks will be sufficiently contained or whether they pose unreasonable danger to themselves, passengers, and other roadway users. The Responsibility filter requires a judgment call in determining if Option 3 is indeed a Right thing to do.

GO. The third and final step of the STOP - THINK & GO Decision-Making Process is to GO with the safest course of action. If students judge Option 3 to be risk acceptable, they are free to implement it with due care. During this step of the process, students are to restate their driving goal and problem and then describe, in detail, how they will implement this driving action in achieving their goal.

Once the STOP - THINK & GO Decision-Making Process is understood by students, they can learn to execute the process quickly with quality results. They must first STOP and state the driving goal and problem and then THINK of choices to filter that will address the driving risks. When filtering their choices, they must ask themselves three questions:

1. **Right Filter**
 - a. Is this choice a Right thing to do (help/hurt)?
2. **Reality Filter**
 - a. Where is my evidence?
3. **Responsibility Filter**
 - a. Do I feel comfortable with this choice in safely resolving the driving dilemma?

Lastly, they GO with a 3 R's choice and execute it in a safe and caring manner.

Reasons Why Students Fail to use Decision-Making

Decision-making is a topic covered in most, if not all, driver education instruction manuals and yet many students do not use what they have been taught. One of the major limitations of driver safety, and discussed earlier in the unit, is based on what a driver is willing to do. Drivers, who are unwilling to apply what they know, limit their safety. However, many drivers, despite good intentions, never learn how to make effective and responsible decisions. Fournies (1998) has cited a number of reasons why people fail to do what they are supposed to do, nine of which will be discussed here. These reasons will help driver education instructors stay focused in their teaching and alert to reasons which may account for student failure in learning decision-making and other driving related skills.

1. **They don't know why they are supposed to do it**

Students are not likely to Learn decision-making unless they are convinced that the process will benefit them. They need to experience the benefits of decision-making through activity that demonstrates its value. In addition, if we want students to view driving as a decision-making experience, they must be taught driving from that perspective. They must see driving situations as decisions to be made and they must understand the goal(s) to be achieved. They must likewise understand the benefits of decision-making and the pitfalls to those who fail to use the process effectively.

2. **They don't know what they are supposed to do.**

Students may fail to make effective and responsible decisions, because they don't know what they are supposed to do. They must understand the steps of decision-making, how they are sequenced, and the purpose of each step.

3. **They don't know how to do it.**

Students may know why they are to make decisions and what to do, but still fail because they don't know how to do it. Telling and explaining do not guarantee knowing how to do something. Students need practice and feedback while using decision-making. They need to be coached through each step of the process until they can do it easily on their own and with confidence. The process must therefore be taught with care. Instructors must be *consistent* in their teaching, *insistent* in their expectations of its use and *persistent* in their guidance in helping their students to self-improve in its use.

4. **They receive no positive consequences for doing it.**

Students who know how to use decision-making are not likely to persist in its use if they are not recognized for their efforts. Decision-making will be awkward at first and not something that students will continue to do if they think that it really doesn't matter to those teaching the model.

5. They think they are doing what they are supposed to do.

Students are not likely to change what they are doing if they believe what they are doing is correct. Students will improve their decision-making skills if they experience the support of concerned teachers and corrective actions driven by explicit feedback and appropriate modeling.

6. They are rewarded for not doing what they are supposed to do.

Instructors who accept less than well-demonstrated skills, will be accepting and rewarding mediocrity. Students will not correct poor decision-making habits under these circumstances.

7. They are punished for doing what they are supposed to do.

Students will become discouraged if they do not receive praise for their efforts. When students are learning to make decisions, instructors need to recognize any improvements they make in using the decision-making process.

8. They anticipate negative consequences for doing it.

Students need to know that their instructors will set high standards for their performance and will encourage them to try new behaviors. Students need to understand that their questions are encouraged, that help will be provided when asked, and that they will experience occasional failure during the learning process but will not be punished for their efforts to succeed. Using this approach, students will be free to learn and will feel safe and secure during the learning process.

9. They experience no negative consequences for poor performance.

Poor performance left unchallenged will go unchanged. Negative consequences must be balanced with positive support. Failure to perform correctly and responsibly should result in a temporary suspension of driving instruction. Decision-making will improve when poor decision-making performance is not tolerated.

Decision-Making Applications

The STOP - THINK & GO Decision-Making Process has a wide range of applications in driver education. These applications will afford students the opportunity to apply driving information, skills, and understandings from a decision-making perspective. What follows is a brief explanation of several of these applications.

Case Situations

Students are given case situations that present a variety of driving dilemmas to be addressed from a decision-making perspective. Students are to identify the driving goal and problem, risk factors and dangers, and potential driving options. They are then to filter their options and arrive at driving decisions that will solve the driving dilemma with minimal risk to human life.

Students can be presented with teacher-made case studies that reflect the presentation and discussion of lecture material or students, working alone or in small groups, can develop their own case situations from lecture information. The case studies can then be processed from a decision-making perspective. Student understanding of teacher lectures and readings can thus be determined through the development and processing of case situations.

Exams

Students can be presented with several mini case situations that relate to course content. They are then provided with four multiple choice options per case situation to be considered for implementation. Students are to describe each driving dilemma, identify risk factors and dangers, and provide a rationale based on Right, Reality, and Responsibility which supports each selected driving option for implementation. Credit is awarded for each component of the response. This type of examination reinforces the importance of decision-making, devalues the memorization of information, and greatly reduces mindless guessing because students don't receive credit for just selecting a viable option. They must reveal the thought process that goes into their choice selections.

Similar exams can be fashioned using slides and video segments that present driving dilemmas. The students must describe the dilemmas, risk factors, and filter their own choices in arriving at low risk solutions to the presenting dilemmas.

Slide Video Case Situations

Slides depicting driving dilemmas are an advanced form of written case situations. In the written case study, the information depicting the driving situation is provided. However, in slide presentations, students must provide their own narration for each slide and identify the risk factors and dangers from their commentary. As students become more adapt at processing written and slide dilemmas, they can be introduced to video situations which add new dimensions of motion and time. No longer are the case situations of a static nature. Rather, students must rely on their perceptual skills and process dilemmas as they unfold.

Simulations

Some driving situations can be duplicated in the classroom and then processed using decision-making. Driving situations that occur sporadically or are just too dangerous to experience on the highway represent great opportunities for simulations.

A simulation is a recreation of an actual driving event practiced in a controlled setting which allows for the manipulation of environmental conditions, replays, and safety. For example, a

driver education instructor can recreate a railroad-crossing situation in the classroom. Two, twelve-foot 2x4's can be used to simulate railroad tracks while two students holding broomsticks can become the gates. The class is asked to line up in front of the gates which are in the down position. The first group of ten students is instructed beforehand to walk up to the gates, look both ways, and walk around the gates. The next group of five students is given no instructions.

The last group of students is instructed beforehand to put pressure on those in front of them if they do not walk around the gates on their own. What usually happens is that the second group of students will "play follows the leader" and walk around the gates. However, if this does not happen, the peer pressure usually gets results.

Following the railroad crossing simulation, the class would be asked to process the presenting dilemma using the STOP- THINK & GO Decision-Making Process. Further discussion would reveal the danger of going around gates and how "follow the leader" behavior and peer pressure do actually occur in such settings. The class would then discuss options to combat respondent behavior and peer pressure and how they might be implemented. Further enactments of the railroad dilemma would follow.

Role Plays

Role plays, while similar to simulations, are different in that they involve acting out solutions to dilemmas of an interpersonal nature. Role plays, like simulations, occur in controlled environments and help students to explore their feelings, thoughts, and actions in response to specific life events while remaining in a safe environment. Role playing gives students an opportunity to explore new ways of behaving in search of acceptable solutions to new and existing life events.

Some examples of role play situations are as follows:

- You always wear a seat belt when driving and expect your passengers to do the same. A friend of yours accepts a ride to school with you. He does not put on his seat belt. He tells you that they are uncomfortable and since you are only 3 miles from school, why bother.
- You are walking home from school. A friend of yours stops to pick you up. As you are driving down the road, you think you smell alcohol on your friend's breath.
- You are taking a driver education class and tell a friend that you are learning how to make effective driving decisions. Your friend tells you that you don't need to learn decision-making to drive a car. You just get behind the wheel and drive.
- You approach a railroad crossing. The gates are down. You don't see any train and your two passenger friends urge you to drive around the gates.

In each of these role-play situations, students using the STOP - THINK & GO Decision-Making Process, are to explore and act out a variety of choices in search of caring and responsible solutions.

Crash Reenactments

While newspaper information describing a highway crash is limited in scope, enough information is usually printed to infer some of the factors leading up to and causing the crash. From this information, the driving situation can be processed using the STOP - THINK & GO Decision-Making Process. Students can discuss the risk factors and dangers associated with the driving situation and how the crash might have been avoided.

Behind-the-Wheel Decision-Making

The ultimate goal of driving is for the driver and passengers to get from where they are to where they are going safely. The problem is how to do it. When student drivers are behind-the-wheel, they must continually scan the environment for risk factors and dangers. They must be aware of highway controls, road conditions, and environmental cues from other users. As they drive, students can verbally identify what their bodily senses are telling them about their driving situation and how they are using that information to increase their safety.

For example, a driver, using commentary driving, might say the following: *"I see road construction signs ahead. I must reduce my speed. A car is following me at two car lengths, so I must increase the space between myself and the car ahead of me. This will give me more stopping distance and the driver behind me more time to gain control of his/her car, should I have to stop quickly"*. This driver is using the STOP - THINK & GO Decision-Making Process and the Right, Reality, and Responsibility filters as is evidenced by the decisions being made.

Driver education instructors, who use decision-making in their teaching, convey to their students a valuable lesson. The students learn that they do not receive credit in class for what they know. The students only receive credit for being able to use what they know in making responsible decisions.

Students learn to enjoy decision-making focused classes because they are active participants in the learning process, not merely passive, inactive, receptacles of knowledge. They come to view driving as a process for which there are no stock answers only contextual cues from which decisions can be made.

Driver education teachers like decision-making focused classes because they no longer have to rely on hours of lecture time to get their points across. Instead, they can require their students to read book chapters and review fact sheets on their own. Class time can then be spent reviewing materials and involving students in activities in which they apply lessons of the classroom to simulations, role-plays and real life driving situations that require them to make thoughtful and responsible decisions.

Activities

What follows is a series of activities that will help your students understand the importance of decision-making as it relates to driving. The activities have been sequenced in the order that they should be experienced.

1. My Life Has Value
 - a. Objectives:
 - i. To help students understand that life has value.
 - ii. To help students understand what gives their lives value.
 - iii. To help students recognize that what they care for will care for them.
2. The Chair Jump
 - a. Objectives
 - i. To help students recognize that people act without thinking and often lose what they value most.
 - ii. To help students understand the importance of thinking before they jump (act).
3. The Rope & Can
 - a. Objectives
 - i. To teach students the value of decision-making.
 - ii. To teach students how decision-making reduces human error.
 - iii. To help students understand the dangers in being a reactor.
4. Creatures of Habit
 - a. Objectives
 - i. To help students understand the meaning of habit.
 - ii. To help students recognize that they are creatures of habit.
 - iii. To help students identify helpful and hurtful driving habits.
5. Awareness of Risk
 - a. Objectives
 - i. To help students identify driving risk factors.
6. Responding to Risk
 - a. Objectives
 - i. To help students learn five strategies for managing driving-related risks.
 - ii. To help students understand the importance of the human factor in causing vehicular crashes as well as promoting safe driving behaviors.
7. Decision-Making Process
 - a. Objectives
 - i. To teach students how to become effective risk managers using the STOP- THINK & GO Decision-Making Process.

Activity: My Life Has Value

Objectives:

1. To help students understand that life has value.
2. To help students understand what gives their lives value.
3. To help students recognize that what they care for will care for them.

Group Size: Any size classroom group

Time Required: 15-30 minutes

Materials: \$100.00 bill (\$20.00 bill can be used)

Message to Facilitator:

Most students understand the value of money, but they are less likely to understand how to equate (measure) value in themselves. The purpose of this activity is to help your students recognize that life has value, to discover value in themselves, and to recognize the importance of caring for what they value. Driving can be a fun and purposeful activity. It can give people their independence, help them to become self-sufficient, and support their recreational interests. Driving also is a dangerous activity, one that is responsible for much human suffering, injury, permanent disability, death, and untold property damage. If we value human life, then we must care for what we value by making caring choices. When drivers care for themselves, their passengers and other roadway users, they enhance safety.

Process:

1. Present your students with the following situation. Have them form a circle (standing) and then place a \$100.00 bill in the center of the floor. As they are looking down at the bill, tell them to imagine that it belongs to them. Having noticed the bill, ask them what they would do, leave it there or pick it up.
2. Most students will tell you that they would pick it up. Ask them their reason for picking up the money, and where they would put it. Most students will tell you they would retrieve the money because it has value and that they would secure it in a safe place (wallet, pocket, and purse).
3. Now ask for a volunteer to stand where the \$100.00 bill was located. Tell your students to imagine that they are now looking at themselves. Then say to them, "You all know that money has value, but how do you equate value in yourselves?" Give them some time to respond and then ask them, "What are you doing to take care of yourself?"
4. If they don't know what gives them value, ask them how many would be willing to give up their eyesight for the \$100.00 bill
5. Help your students to recognize that people only care for what they value. People who value their eyes will take care of them.

Discussion/Evaluation:

1. Imagine sharing the roadway with people who do not recognize value in themselves or other people. What would our highways be like and what would it be like to drive on them?
2. How can you make a difference? What driving choices are you willing to make to care for yourself and other roadway users?
3. Driver Education is a course in caring. What does the statement mean to you and do you agree with it? Explain.

Homework:

1. Have your students observe the driving behaviors of others at intersections, on the open road, at railroad crossings, cross walks, stop signs, traffic lights, snow or water covered roads, etc. How many people are making caring choices and how many people demonstrate a disregard for human life?
2. Have your students read and clip articles from newspapers reporting roadway crashes. Ask them to describe these crashes and the driving choices that caused them to occur.
3. Finally, ask your students to draw some of their own conclusions regarding the state of highway safety in this country. Ask them whether they **plan** to increase the danger on our highways or contribute to highway safety by making caring choices?

Activity: The Chair Jump

Objectives:

1. To help students recognize that people act without thinking and often lose what they value most.
2. To help students understand the importance of thinking before they jump (act).

Group Size: Any size classroom group

Time Required: 15-30 minutes

Materials: A sturdy chair

Message to Facilitator:

Impress upon your students that life does have value. We would not be a society of laws, social institutions, consumer protection agencies, medical research, technological advances, and highway safety programs if life did not have value. We could become a much safer society if people would make caring choices by using all of the safety information, resources, and technology at their disposal. This definitely applies to highway safety.

The Chair Jump exercise effectively illustrates that many drivers do not think before they act and jeopardize the very elements of life and living they value most. Unfortunately, too many people only recognize, after the fact, what they have sacrificed and then it is too late to prevent the preventable. Impress upon your students that all of their choices have the potential for either helping or hurting themselves and others. They need to choose wisely by thinking before they act.

Procedure:

1. Select a responsible student for this exercise, one who listens to instructions and follows directions.
2. Place a solid four-legged chair on non-skid material (carpet) and hold it from sliding during this exercise.
3. Invite a student volunteer to come to the front of the room and sit in the armless chair provided. Tell the class that our volunteer will do as instructed and that today we want this person to stand on the seat of the chair. On the count of three (1-2-3), this person is to jump from the chair to the floor (landing on his/her feet). After the first jump, the volunteer is again instructed to stand on the chair and to jump once again on the count of three, but this time land on his/her face.
4. Ask your class why they think the volunteer did not make the second jump. The answer is that this person values his/her face and therefore made a caring choice to protect what he/she values. This person paused long enough to think about how this choice would impact his/her life. The moral of this activity is to think before you leap. Too many people in life are chair jumpers. They fail to see the danger in their actions until it is too late to do anything about it.

Discussion/Evaluation:

1. What do you value about yourself, others, and the environment that you would protect at all cost?
2. What are some driving choices that people have made without thinking? Some "chair jump" choices of drivers are:
 - a. Passing on double lines
 - b. Running red lights
 - c. Failure to stop at stop signs
 - d. Drinking and driving
 - e. Failure to scan intersections before making a turn
 - f. Driving at excessive speed
3. Sometimes drivers lose the very things they value most when they "act without thinking." What are some of those losses? (Loss of life, mobility, freedom, health, friends, license, trust of others regarding their judgment, etc.)
4. What is one thing that you can do before you jump (act)?
 - a. *Ans. THINK! Will this choice help or hurt me, others, and the environment?*

Homework:

1. Have your students identify choices that roadway users have made that have either resulted in caring actions or caused them to lose what was important to them?
 - a. Choice: Driving while angry
 - b. Result: Road rage resulting in violence
 - c. Choice: Drinking and driving
 - d. Result: Loss of a friend's life
 - e. Choice: Driving over the speed limit
 - f. Result: Loss of control—damage to property & vehicle
2. Ask your students how many of them would be willing to sign a pledge which stipulates that they are committed to making caring driving choices? Impress upon them the magnitude of their commitment and oath. Pass out the pledges, have students read and sign them, and post them in class.

Driver Safety Pledge

(Name) _____ pledge to think before I jump. I will make caring driving choices that will enhance my personal safety and the safety and welfare of my passengers and those with whom I share the road. My driving choices are important, because they **will impact my life and the lives of others who are touched by my choices.**

(student)

(Driver Education Instructor)

Activity: The Rope and Can

Objectives:

1. To teach students the value of decision-making.
2. To teach students how decision-making reduces human error.
3. To help students understand the dangers in being a reactor.

Group size: Any size group

Time Required: 15 minutes

Materials: 15 to 20-foot rope, small table (desk), and can

Message to Facilitator:

Explain to your students that people usually address life situations as wishful thinkers, responders, or decision-makers. Wishful thinkers often accept risks without knowing what they are. They act and then hope for the best. A wishful thinker will pass a car on a hilly two-line road, marked with two solid lines. Their action rides on blind faith, hoping that their wish for a successful pass will be granted and that everything will turn out okay. Responders are people who react to environmental conditions? Their behaviors are triggered by life events. No thinking is required. Responders will execute the first action that "pops into their head." For example; responders will fail to reduce speed on a snow-covered road. They will wait until their car begins to skid before they brake.

In contrast, decision-makers will use environmental data (snow covered road) in generating and examining choices that will help them to solve their problem and reach their goal. They will choose to reduce their speed to maintain traction and avoid loss of control of their vehicle. The Rope and Can activity demonstrates respondent behavior and illustrates four errors" that responders make when faced with a challenge. The same activity can also illustrate the STOP - THINK & GO Decision-Making Process and its value in making caring and responsible choices.

Procedure:

1. No prior explanation of this activity is required. Ask for a volunteer to come forward. Explain that the volunteer is to place a rope loop around his/her waist with the knot at his back. The facilitator places a vegetable can or small object on a table/desk out of the volunteer's reach. Taking the end of the rope, the facilitator instructs the volunteer to retrieve the can. The rope should be somewhat slack at the beginning of this activity.
2. Responders will see the rope as an environmental barrier and will pull on it to get to the can. The volunteer will lose sight of the goal (to retrieve the can) and will see only one way to get the can which is to pull on the rope.
3. When you ask the volunteer to explain what is holding him/her back, this person will say the rope.

4. Now introduced the STOP -THINK & GO Decision-Making Process. Ask your volunteer to state his/her goal and problem.
 - a. Goal: To retrieve the can.
 - b. Problem: How can I retrieve the can?
 - c. Think: Ask your volunteer to identify options (choices) for retrieving the can.
 - d. Go: Tell your volunteer to go with a choice that will help him/her achieve the goal
5. What your students will recognize very quickly is that it was not the rope that was holding back the volunteer, but rather it was his/her respondent behavior. The minute your volunteer is instructed to pause between STOP - THINK & GO, this person will identify multiple ways to retrieve the can. No longer is the volunteer stuck with the first response that comes into his/her head. Rather, your volunteer will view the rope as a piece of information to be addressed in achieving the goal and will cease to pull on it. By stepping backwards toward the facilitator, the volunteer can loosen and step out of the rope and retrieve the can. Other choices might have included asking the facilitator to let go of the rope, asking a classmate to get the can, or asking classmates to give you a stick or something to reach the can.

Discussion:

1. Animals possess the genetic make-up to be responders/reactors. They are dependent on their genes for survival since they are incapable of thought. However, in contrast to animals, human beings are not fine-tuned responders, but rather have the capability to reason and make decisions.
2. When human beings rely on their respondent behaviors, they open themselves up to danger. Many young people have died or been injured when their behaviors were triggered by environmental stimuli.
 - a. Triggering event: Drowning
 - b. Automatic response: Jump into water to save them and end up in a double drowning
 - c. Triggering event: Someone knocks at the door
 - d. Automatic response: Run to open the door without checking to see who is on the other side and get robbed.

Have your students identify driving related triggering events and how people react. Then have them process the situation using the STOP- THINK & GO Decision-Making Process for the purpose of generating safe conclusions to the driving events.

Triggering event	Automatic response
Green light	Hit the gas when the light turns green and get hit at the intersection by someone racing a yellow light.

1. Goal: To get through the intersection safely
2. Problem: How to get through the intersection safely?
3. Think: Brainstorm some choices. One choice might be to pause and look both ways before pulling into the intersection.

4. Go: Go with a caring and responsible choice for you, your passengers and other roadway users.
3. Decision-makers view environmental stimuli as information to be used when processing a safe decision. A responder will follow a line of traffic around lowered gates at a railroad crossing. A decision-maker will use what he sees happening and evaluate it in the context of the STOP- THINK & GO Decision-Making Process.
 - a. Goal: To approach the railroad gates with safety in mind for you, your passengers and other roadway users.
 - b. Problem: How to do this.
 - c. Think: What are my options in addressing the downed gates? Should I "follow the leader" around the gates or think about potential risks in executing this choice and look at other options?
 - d. Go with a safe and caring response.
4. Examine the four human errors presented earlier in this unit that responders commit and examine how they apply to the rope and can, the green light, and the railroad crossing scenarios.
5. Ask your students to evaluate the benefits of decision-making in contrast to respondent actions.
6. Ask your students to consider if they are responders or decision-makers.
7. How does decision-making relate to the chair jump activity? In the first jump, the volunteer was acting as a responder responding to directions. In the second jump, the volunteer used the STOP- THINK & GO Decision-Making Process.
 - a. Goal: To maintain my safety.
 - b. Problem: How to maintain safety?
 - c. Think: What are my choices and the consequences of each?
 - d. Go: Go with a safe and caring choice

In the second jump, the volunteer paused between STOP & GO to think about the consequences of landing on his/her face and rejected this action as too risky.

8. How does decision-making relate to the \$100.00 bill activity? If caring people are to protect and care for what they value, they must be decision-makers and not responders.

Activity: Creatures of Habit

Objectives:

1. To teach students the value of decision-making.
2. To teach students how decision-making reduces human error.
3. To help students understand the dangers in being a reactor.

Group size: Classroom-size group

Time Required: 30 minutes

Materials: Chalkboard and chalk

Message to Facilitator:

Help your students to recognize that habits represent routine, automatic patterns of thought and behavior (action) that are practiced without thinking. Because habits are automatic, practiced routinely, and are devoid of thought, they become very comfortable and difficult to give up. Helpful habits are based on Right, Reality, & Responsibility and are practiced in predictable and stable (consistent) environments. For example, when crossing a street, pedestrians can benefit from the habit of looking to the left, then to the right, and the left again to check for traffic before stepping onto the pavement. This is a good habit to practice because the traffic closest to the pedestrian will generally be coming from the left. However, habits become harmful when they expose people to danger. If a person from the United States uses the same street crossing habit in Europe, this person is more likely to be hit by a motor vehicle because cars will be approaching from the right, not the left. Students need to understand the benefits and dangers of habits, how to distinguish good habits from harmful ones, and to recognize that they are creatures of helpful and harmful habits.

Process:

Ask your students to stand facing you. Tell them to stretch their arms to the side and raise them to shoulder height with their palms down. Tell them to drop their dominant arm (left or right) to their side. While in this position, using their one outstretched arm for balance, have them work their lowered arm and hand down the outside of their leg and touch their ankle. Most students will perform this task without bending their knees even though the task is easier to perform with their knees bent. Because of past programming (physical education class), most students have developed the habit of ankle/toe touching with their knees straight. Demonstrate for your students, ankle touching while bending your knees.

Another activity to illustrate habit is arm folding. Ask your students to fold their arms over their chest. Ask them to reverse the fold. Most people have to stop and think about what they are doing. For most students, the first way they folded their arms is more comfortable than the second due to habit.

Discussion:

1. Ask your students to indicate why most of them performed the ankle touching behavior with straight knees when they could have more easily performed the task with their knees bent. The answer is habit. *They programmed themselves* to perform the behavior with their knees straight.
2. Have your students brainstorm a variety of driving related habits (good & bad):
 - a. Adjusting mirrors and driver's seat before starting the car
 - b. Checking tire pressure, oil level, and other fluid levels
 - c. Wearing a seat belt
 - d. Not coming to a complete stop at intersections
 - e. Speeding
 - f. Tailgating
 - g. Eating & driving
 - h. Leaving keys in the car
 - i. Not locking doors
3. Ask your students how they can distinguish helpful habits from harmful habits.
 - a. Ans.: Harmful habits are not based on Right, Reality, and Responsibility. There is no evidence to support the benefits of those habits. The habits have negative consequences and are not practiced by responsible drivers.
 - b. Helpful habits are practiced in routine, unchanging, and predictable environments. They are based on the 3R's. If the driving situation is constantly changing, drivers must Use their decision-making skills in determining the best course of action to take.
4. Have your students classify helpful and harmful driving habits using the generated list of driving habits. Ask them to filter each habit through the Right, Reality, & Responsibility filters in making their determination.
5. Ask your students to explain what personal benefits they can derive from habits.
6. Ask your students to identify driving habits they would like to have.
7. Ask your students to name harmful driving habits they wish to avoid.

Activity: Awareness of Risk

Objective:

To help students identify driving risk factors.

Group Size: Small discussion groups (4 to 5 people per group)

Time Required: 30 minutes

Materials Needed: None

Message to Facilitator:

The purpose of this activity is to help your students understand that driving is a dangerous activity due to the many risk factors that impact the driving experience. Before students can become effective risk managers, they must first become aware of the risks.

Procedure:

1. Explain to your students the meaning of risk and risk factors.
 - a. Ans: Risk refers to the degree of personal danger to which one is exposed when participating in a hazardous activity. Risk factors relate to those elements that have the potential for causing injury, death or property damage.
2. Explore with your students that driving a motor vehicle is a complex and dangerous activity involving the interaction of four key variables: driver, motor vehicle, roadway conditions, and other roadway users. Each of these variables presents a number of risk factors that have the potential for causing motor vehicle crashes. Ask your students to brainstorm a list of crash causing risk factors for each of the mentioned variables.

Driving Risk Factors:

- Driver-related factors
 - Emotions
 - Medications
 - Drugs & Alcohol
 - Fatigue
- Motor vehicle-related factors
 - Tires
 - Radio
 - Windshield
 - Brakes
- Roadway conditions & environmental distractions
 - Pot Holes
 - Road Curves
 - Hills
 - Ice/Snow/Rain
- Factors from other roadway users
 - Aggressive Driver

- Failure to Yield
 - Failure to Signal
 - Tailgating
3. For each risk factor mentioned, have your students list some of the dangers they present.
 - a. Example:
 - i. Risk factor:
 1. Emotions (fear, anger, sadness, etc.)
 - ii. Danger:
 1. Inattention
 2. Lack of concentration
 4. Because driving involves the interaction of risk factors, have your students create some driving scenarios that demonstrate the presence of danger.
 - a. Example: Following a heated argument with his girlfriend. Joe jumps into his car burning with anger. Driving on bald tires, in a heavy rain, he races up the street with the radio blaring.
 5. Following the creation of these scenarios, have your students exchange them with each other. Ask them to identify the risk factors and potential dangers to driver, passengers, others roadway users, and property.

Discussion/Evaluation:

1. When you drive a motor vehicle, you are in danger because of the ever-present risk factors that impact this activity. Do you agree or disagree with this statement? Explain.
2. The degree (amount) of danger (risk) experienced by all drivers is the same. Agree or Disagree? Explain.
3. Drivers can reduce their risk of injury, disability, and death. Agree or Disagree? Explain.
4. The cause of most motor vehicle crashes is (a) poor road conditions; (b) vehicle/mechanical problem; (c) human error. Choose a response and explain your selection.
5. The most effective way to reduce vehicular crashes is to (a) build safer cars; (b) improve road conditions; (c) teach drivers how to manage risk. Explain.

Homework:

Have your students observe drivers and the risk factors that impact the driving situation. Ask them to record driver actions that either increase or decrease the risk of driving related injuries and death.

- Example: Speed is a risk factor. Drivers who exceed the speed limit or drive at speeds that are unsafe for current road conditions are choosing an action that increases their risk of being injured or killed.

Activity: Responding to Risk

Objectives:

1. To help students learn five strategies for managing driving related risks.
2. To help students understand the importance of the human factor in causing vehicular crashes as well as promoting safe driving behaviors.

Group Size: Classroom group or small groups

Time Required: 30 minutes

Message to Facilitator:

Help your students to understand that taking risks is a part of life. Risk-taking is unavoidable and adds quality to our lives. In the absence of risk-taking, human growth would cease and excitement and adventure would hold little meaning in a world of boredom and flat line living. However, risk-taking, if it is to be productive, must be managed otherwise it has the potential to result in injury, disability, and death. This activity will introduce five strategies that students can use that will allow them to participate in risk-taking activities, such as driving a motor vehicle, in a climate of relative safety.

Process:

1. During the first half of this activity, you will be teaching your students five different ways they can manage danger in their lives. Each method will be defined and accompanied with an example. Following each example, is a question designed to stimulate further discussion of the risk management method.

Methods:

- A. Risk Avoidance. When a situation is judged by a roadway user to be so dangerous that the risk of injury, death, or property damage is high, a wise decision would be to avoid the dangerous situation.
 - a. *Example: John avoids personal risk to himself, his passengers and other roadway users by choosing not to pass the car ahead of him on a road marked with two solid yellow lines*
 - b. *Discussion: Ask your students to consider driving behaviors (actions) they would avoid because the potential danger involved would place themselves, others, and property at high risk.*
- B. Risk Prevention. Many driving related risks can be lowered in advance of their occurrence by taking early corrective action. This is called prevention.
 - a. *Example: Susan checks the air pressure in her tires every month, rotates her tires every 6000 miles, and maintains a tire tread depth above 1/16 of an inch.*
 - b. *Discussion: Ask your students to consider all of the preventive steps they can take to enhance their driving safety before they turn on the ignition.*

- C. Risk Reduction. Driving related risks that are addressed while driving is known as risk reduction.
 - a. *Example: While driving, Bill continually searches his environment, adjusts his speed according to road conditions, and signals his driving intentions in advance of executing a lane change or turn.*
 - b. *Discussion: Brainstorm a list of risk reduction actions that drivers can execute while driving.*
 - D. Risk Protection. Physically taking care of one's body while participating in a risk-taking activity is known as risk protection.
 - a. *Example: Jean wears sunglasses on bright sunny days to protect her eyes from the glare and to increase her field of vision. She also wears her seat belt.*
 - b. *Discussion: Ask your students to consider what risk protection practices they could take as pedestrians, bicycle riders, vehicle passengers, and drivers.*
 - E. Risk Acceptance. When people have done what they can do to manage risk, they must then decide if they are willing to accept the remaining known and unknown risks and participate in the activity. While few activities are completely safe, most people are willing to accept calculated risks where the odds for safety are in their favor.
 - a. *Example: John, Susan, Bill, & Jean recognize that driving a motor vehicle can be dangerous. However, they are willing to accept the risks knowing that they have taken steps to manage the known risks through risk prevention, risk reduction, and risk protection measures.*
 - b. *Discussion: Ask your students if they believe that many motor vehicle drivers and passengers readily accept the risks of driving without actually knowing the risks? Ask them to explain their answers and provide examples to substantiate their position.*
2. Now that your students understand the five methods of risk management, ask them to brainstorm major causes of vehicular crashes. Then ask them to apply the five methods of risk management in ways that will reduce vehicular crashes.
 - a. Example:
 - i. Cause of crashes: Lane changes
 - ii. Risk management methods:
 1. Risk prevention: Make sure your signal/lights work and can be seen (keep them clean). Position your seat and mirrors to maximize visibility.
 2. Risk reduction: Use your mirrors. Signal your intention. Wait for space to clear and proceed with caution.
 3. Provide your students with case scenarios or have them use ones they developed in the previous activity "Awareness of Risk". Ask them to identify the driving risks and how they would manage them using one or a combination of the risk management strategies presented.

Discussion/Evaluation:

1. Ask your students what they believe is the cause of most driving crashes.
 - a. Ans. Too many drivers are unaware of the driving risks, or if aware of them, they do nothing to manage them to increase their driving safety.
2. Ask your students if driving is more of a physical or mental activity. Have them explain their answer.
3. Ask your students to define what they believe constitutes a safe and responsible driver.
4. Ask your students what safe and responsible drivers must do.
5. Ask your students what they are willing to do to become safe and responsible drivers.

Homework:

Many safety experts agree that human error or behavior is the leading -cause of vehicular crashes and that safety is primarily a human issue. Human beings are the primary cause of crashes and only they can reduce death and injury rates from crashes by assessing and changing their high- risk behaviors, habits, and attitudes. Ask your students to do a self-inspection and identify those human elements (risk factors) within themselves that put them at risk and some strategies they can take to lower their risks. To help them get started, discuss some of the following human risk factors in class. Age is a risk factor that affects every teenager. What are the dangerous effects of these risk factors and how can they be safely addressed.

Human Risk Factors

- Age (why is age a risk factor)
- Sex (gender is a risk factor)
- Stress (physical/emotional)
- Emotions (fear sadness, anger, etc.)
- Fatigue
- Illness
- Hearing loss
- Impaired vision
- Physical disability
- Mental disability
- Alcohol/drug use
- Smoking and driving
- Eating while driving
- Cell phone use in vehicle
- Lack of hand/eye coordination
- Lack of driving experience
- Lack of driving knowledge and skills
- Imitation/poor role models
- Unsafe attitudes that effect driving choices (inclination to speed, etc.)
- Unsafe habits (failure to buckle up, etc.)

- Susceptibility to peer pressure
- Easily distracted
- Society's values (Competitive behavior, aggressive style, toughness, thrill seeking, and risk taking are American values taught in some homes and schools.)

Activity: STOP- THINK & GO Decision-Making Process, Teaching the Model

Objective:

To teach students how to become effective risk managers using the STOP - THINK & GO Decision-Making Process.

Group Size: Classroom size group

Time Required: 30 to 45 minutes

Materials needed:

1. The Crash (Case Situation)
2. STOP- THINK & GO Decision-Making Process Worksheet

Message to Facilitator:

Teaching young people decision-making is an essential component of learning to become a safe and responsible driver. Young people need opportunities to practice processing driving situations in safe and controlled environments where they can receive proper guidance and essential feedback in developing this process. By discussing case studies, slides, and videos depicting a range of driving challenges, you will be helping your students address complex driving situations using a systematic and logical risk management process. Your students will learn that every driving situation is different. The only constant is the decision-making process they will be using. They will likewise learn that information has value to the extent that it can be used in making safe and responsible decisions.

Decision-making is first taught and executed in slow motion. Students need time to learn the process and apply it to simulated and real driving situations. Once learned, the STOP - THINK & GO Decision-Making Process can be applied as quickly as you can say STOP – THINK & GO.

Process:

1. Explain to your students that you will be teaching them how to make safe and responsible driving decisions using a traffic signal light model (STOP - THINK & GO).
2. Give your students a copy of *"The Crash"* case study and the *"STOP- THINK & GO Decision-Making Worksheet."*
3. Tell your students that the decision-making model will help them to process complex driving situations leaving them with safe driving options to process in response to their driving challenges.
4. Guide your students through the decision-making process using "The Crash" case study and "The Decision-Making Instructional Guide."

Decision-Making Instructional Guide

The Crash

Wanting to spend more time with her parents and friends during Spring Break, Susan leaves college after her last class at 4:00 p.m. on a Friday afternoon to begin her 300-mile drive home.

By 5:30p.m., the sky darkens, and a light rain begins to fall. The two-lane road is now dark, and visibility is poor. By 9:00p.m., Susan is only 10 minutes from home. Consumed with thoughts of excitement and plans for the coming days, Susan is overcome by fear as her car, seeming to have a mind of its own, drifts off the road, strikes a ditch, and flips onto the roof. Although injured, Susan survives.

I. Stop

1. Describe the driving situation.
 - a. Have your students summarize "The Crash" in a few sentences capturing the essence of what happened.
 - b. *Example: Susan drives a distance of approximately 300 miles in 5 hours on a dark, wet, two-lane road, where visibility is poor. Her car leaves the road & flips over.*
2. State the driving goal.
 - a. Explain to your students that the driving goal for safe drivers is stated the same way each time that it is written.
 - b. *Example: To get from where I am to where I want to be safely.*
3. State the driving problem (question).
 - a. Explain to your students that the driving problem is always stated as an open-ended question to be solved.
 - b. *Example: What must I do to get from where I am to where I want to be safely?*

II. Think

1. Identify the risk factors and dangers in this driving situation.
 - a. Tell your students that risk factors represent those aspects of this case situation that could cause injury, death, or property damage. For each risk factor, there are potential dangers. Multiple risk factors create multiple dangers.
 - i. Example:
 1. Risk Factors:
 - a. *Visibility*
 - b. *Traction*
 - c. *Speed*
 - d. *Fatigue*
 - e. *Distraction*
 2. Dangers:
 - a. *Wet roads and darkness reduce visibility*
 - b. *Wet roads decrease traction and increase the possibility of hydroplaning.*
 - c. *Speed on wet roads reduces traction and increasing the potential for hydroplaning.*
 - d. *Tired drivers lack concentration*
 - e. *Susan was distracted by her thoughts (vacation planning)*

3. *These collective risk factors and dangers increase the potential for loss of vehicle control.*
2. Identify driving choices that address the risk factors and dangers.
 - a. Explain to your students that they are to identify driving choices (options) that will reduce or eliminate these risk factors and dangers.
 - b. *Example:*
 - i. *Susan should adjust her speed to road conditions (rain) and visibility (darkness).*
 - ii. *Susan should slow down and adjust her speed to road conditions and visibility, take periodic rest stops, and keep her mind focused on the roadway area for potential hazards.*
 - iii. *Susan should get a good night's rest and begin her trip Saturday morning.*
 3. Filter Your Choices
 - a. Right Filter (consider the risk factors)
 - i. Is this choice Right (legal, ethical, moral)?
 - ii. How will this choice effect the driver, others, and property?
 1. Help your students to understand that the purpose of the three filters (Right, Reality, and Responsibility) is to separate safe and responsible driving choices from those that could be potentially harmful to the driver, passengers, other roadway users, and property. In preparing to use the Right Filter, ask your students to review their choices and place a check mark next to the choice that they think will pass through all three filters. A Right choice is legal, meets acceptable driving standards, and is respectful of self and others. A Right choice also must be helpful in solving the driving challenge by addressing the risk factors and dangers in question. Choice number 2 has been selected for processing.
 2. Example: Choice number 2 must now be processed through the Right Filter: "Susan should slow down and adjust her speed to road conditions and visibility, take periodic rest stops, and keep her mind focused on the roadway area for potential hazards." The elements of this choice are believed to be legal, meet acceptable driving standards given the identified risk factors and dangers, and will be helpful to Susan in protecting her property (car) and keeping her and other roadway users safe. This choice will pass through the Right Filter.
 - b. Reality Filter (measuring risk)
 - i. How do I know this choice is Right?
 - ii. Where is my evidence?
 1. Explain to your students that the Reality Filter requires them to provide evidence (facts, statistical data, observational information, etc.) that supports the choice being processed as a Right thing to do. What evidence can your students provide that supports the choice being filtered as one that will address the risk factors and

dangers in this case study (The Crash) resulting in a safe driving conclusion to this situation?

2. Example: According to R.A. McInenly, author of *Safety Sense on the Road*... single vehicle crashes account for 21% of all traffic deaths. "A mixture of darkness, excessive speed, fatigue, and poor concentration can quickly lead to an unexpected crash"(McInenly, 1988, p3). These risk factors are present in "The Crash" case study. McInenly has stated that to reduce single car crashes, the driver should match speed to road conditions, slow down when driving at night and driving in inclement weather, take periodic rest breaks in safe areas, and eliminate distractions. Choice number 2 address the risk factors and dangers in this case study with actions that are documented in *Safety Sense on the Road* by R.A. McInenly.

c. Responsibility Filter (judging risk)

- i. Am I risking more than I can afford to lose?
- ii. Am I risking a lot for a little?
- iii. Do I feel comfortable with this choice?
- iv. Will this choice help me get there safely?
 1. Help your students to understand that while measuring risk (Reality Filter) is an objective and scientific process, judging risk is a personal and subjective activity. Knowing the consequences and probability of risk still leaves the driver with having to decide whether to accept or reject the choice being filtered.
 2. Example: Susan's choice to speed at night on wet roads, to save time and get home quicker to start her vacation earlier, placed her and other roadway users in harm's way. Had she asked herself the four questions in the Responsibility Filter, she probably would have decided differently. Choice number 2 addresses the risk factors and dangers in this case study and would likely pass through the Responsibility Filter. However, some students might reject choice number 2 as being too risky given that Susan is tired and that single vehicle crash rates increase after dark. Some students might prefer processing the third choice: "Susan should get a good night's rest and begin her trip Saturday morning."

III. Go

1. State your selected driving choice(s)
2. Explain how this choice will meet the driving goal.
 - a. Explain to your students that they are to provide a narrative (verbal or written) explaining how they will execute the selected driving choice(s). They are to consider risk prevention, risk reduction, and risk protection methods they would use in describing how they would handle this driving situation.

- b. Example: Choice 2: Susan should slow down and adjust her speed to road conditions and visibility, take periodic rest stops, and keep her mind focused on the roadway area for potential hazards. A few days before Susan takes her trip, she should make sure her car is mechanically sound that her tires have good tread, and that they have been properly inflated. Susan will begin her trip at 4:00p.m. on Friday and will plan to make rest stops every two hours and more frequently if needed. As night falls and it begins to rain, Susan lowers her speed because of reduced visibility and traction. Wet road surfaces and speed increase skidding and hydroplaning while lowering speed increases traction. Susan also turns on her radio, rolls down her windows and concentrates on the roadway and surrounding area for potential hazards. She erases thoughts of family fun from her mind so as to reduce distractions and increase her odds of arriving safely at her destination

Worksheet: STOP- THINK & GO Decision-Making Process

I. STOP

1. Describe the driving situation.
2. State the driving goal.
3. State the driving problem (question).

II. THINK

1. Identify the risk factor and dangers in this driving situation.
 - a. Risk Factors:
 - b. Dangers:
2. Identify driving choices that address the risk factors and dangers.
3. Filter Your Choices. The filters will help you to select safe and responsible choices to your driving problem. If a choice is unsafe or hurtful, it will not pass through all three filters. Select one of your choices to filter and place a check mark next to your selection.
 - a. **Right Filter** (consider the risk factors)
 - i. Is this choice right (legal, ethical, and moral)?
 - ii. How will this choice effect the driver, others, and property?
 - b. **Reality Filter** (measure risk)
 - i. How do I know this choice is right?
 - ii. Where is my evidence?
 - c. **Responsibility Filter** (judge risk)
 - i. Am I risking more than I can afford to lose?
 - ii. Am I risking a lot for a little?
 - iii. Do I feel comfortable with this choice?
 - iv. Will this choice help me get there safely?

III. GO

Explain how this choice will help you to solve this driving problem safely. Restate your driving goal, problem, and driving choice(s). Explain how you will implement this choice and why you believe that it will bring a safe conclusion to the driving situation.

Goal:

Problem:

Choice:

Response:

Conclusion

Now that your students understand the importance of decision-making and how to implement this process, be sure to integrate this model into the remaining units of this manual. Perceptual training and nighttime driving are decision-making based activities that will enhance safe driving practices.

The following decision-making template, if followed, will enable you to process written case studies, slides, video segments, and commentary driving using the STOP - THINK & GO Decision-Making Process.

I. STOP

1. Describe the driving situation by summarizing the key points.
2. State your driving goal: *"To get from where I am to where I want to be safely."*
3. State your driving problem as a question: "How can I get from where I am to where I want to be safely?"

II. THINK

1. List the risk factors and dangers in this driving situation.
2. List driving choices (options) that address these risk factors and dangers.
3. Filter your driving choices and identify any that will lead to a safe driving conclusion.

III. GO

Describe what you will do to implement your driving choice (option) and how it will lead to a safe conclusion to your driving challenge.

With practice, the STOP – THINK-GO Decision-Making Process will become a routine that can be easily executed in a matter of seconds. Student's will learn to automatically:

1. scan their driving situation;
2. search for risk factors and dangers;
3. identify safe driving options; and
4. execute safe and responsible driving actions.

While changing student behaviors is a difficult process, not to respond to this challenge will place additional young people and other highway users in harm's way. You can make a difference! You can help break the cycle of death and destruction and help your students to become responsible decision-makers and safe drivers. Do it today and save lives tomorrow.

This unit was authored by John C. Worzbyt, Department of Counseling, Indiana University of Pennsylvania, Indiana, PA.

Module III-- Perception and Driving Strategies for Different Environments

Perception and Driving Strategies for Different Environments

This unit is designed to teach the beginning driver selective visual skills for greater car control and seeing. Controlling the speed and position of the vehicle and communicating the driver's intentions to other users is dependent upon the driver's perceptual skills. Complex and constantly changing driving environments require a constant awareness on the part of the driver; and many times, a driver is required to make critical decisions in a very limited time span. This unit will enable beginning drivers to practice the decision-making process in the classroom, the driver education vehicle, and in the parent's car; so that when they are on their own, they will hopefully make the correct decisions.

The Perceptual Driving Program establishes a foundation for selective seeing, evaluating, and responding to selective traffic scenes. Once this process is learned, the beginning driver will then be able to apply it to various traffic environments and situations. When introducing the students to the various driving environments and what makes these environments different from one another, the processes from the Perceptual Driving Program should be applied to all of the planned lessons.

Another important part of visual training is learning to drive at night. There are visual techniques used at night in relation to seeing and controlling the vehicle that are significantly different from daylight driving. Drivers must be aware of what the various problems are, and they must also know how to respond to these problems. This specific phase of the driving task should be greatly enhanced with the classroom introduction, behind-the-wheel experiences, and parent participation.

This unit is primarily comprised of two programs, the Perceptual Driving Program and the Night Driving Program. The Perceptual Driving Program is presented first, and it is important for the instructor to become familiar with the entire program before attempting to teach it. The first part of this program deals with Program Organization and then seven sessions directed to the students.

As an introduction to this unit, the instructor should utilize one class period to review the latest crash data from the Pennsylvania Department of Transportation as it relates to 16 & 17-year-old drivers. Refer to page 142 of Module III for a list of the types of driving maneuvers where teenage drivers are over represented in crashes.

Rationale

The role of the driver in the highway transportation system (HTS) is primarily that of processing information and making decisions. Competent drivers do not just operate and guide vehicles; they are involved in a complex and constant process of perceiving and deciding how best to control the speed and position of their vehicles in one traffic situation after another. Fortunately,

most traffic situations to be encountered are routine and easy to deal with. However, every now and then a rather complex traffic problem arises which drivers must cope with in a very limited amount of time. And, it is the failure of drivers to respond properly to such problem situations that lead to most collisions. Therefore, the development of traffic problem solving skills is a basic requirement of safe driving.

Over the past thirty years, the Defensive Driving Course, the Smith System for Expert Seeing, and the Identify, Predict, Decide and Execute (IPDE) process have been introduced piecemeal into high school driver education programs. Now, for the first time, the best ideas from these programs have been integrated into one comprehensive and coherent program of instruction. Perceptual Driving best describes such a program and it is better understood by students, administrators, and parents. Also, the development of thinking skills and problem solving has become a high priority in the educational reform movement. Therefore, the teaching of problem solving skills in driver education can make a significant contribution to the general objective of high schools as well as traffic safety.

In addition to the driver's mental skills or processes, the unit introduces the five basic requirements that are needed for the safe control of a motor vehicle. Then, they are applied and reinforced during succeeding sessions. These five basic concepts are traction, space, time, visibility, and the path of travel.

- Adequate Traction -- Without traction, vehicle movement and control would not be possible. Traction is required for accelerating, decelerating, and steering. A driver must constantly assess the traction demands of his or her vehicle.
- Adequate Space -- An adequate margin of space gives drivers plenty of time to react to the changing conditions. It also gives them better visibility. As a result, they rarely need to make sudden stops or swerving actions. Space is needed for crossing, joining, turning, and any other maneuver. Space needed, will vary with the speed being traveled.
- Adequate Time -- The driver must assess the time needed for driver control actions, vehicle responses, maneuvers, and processing information. The use of timing is extremely important for avoiding hazards.
- Adequate Visibility-- How well a driver can guide his or her car along a pathway depends on visibility and how well the eyes are being used. Changes in visibility must be perceived and responded to.
- Path of Travel -- The path of travel is that strip of roadway, wide enough and long enough, to permit the safe forward movement of your car. This concept serves as the basic point of reference for all perceptions and evaluations.

Program Organization

This writ of instruction for driver education reflects recent developments and trends in curriculum construction and traffic safety research. The basic approach follows the task analysis procedures that have been developed and utilized for describing and analyzing the human role in the man-machine systems. By describing the human functions in relation to their role in

performing the driving task, emphasis is placed on those mental habits and behavioral processes that can have life-long utility.

A primary objective of driver education is that students are able to make wise and responsible traffic decisions on their own. Therefore, the challenge of these class sessions is the cultivation of the student's own decision-making skills as well as the correct responses to given traffic situations. To this end, students are provided with a set of general strategies that they can apply to complex as well as the more common driving situations.

Design and Structure

The program is designed to provide both teacher and students with a structured sequence of learning experiences, which will enable students to progress in an orderly way to the desired behaviors. It is student centered and self-motivating. One of the goals is "learning to learn" so that students can continue to improve both during and after the course.

The first step in guiding students through the learning process involves motivation. Teachers cannot motivate students, but they can provide the kind of conditions in which students can motivate themselves. Such conditions are provided in this. writ with the use of numerous case studies and the flash-slide activities. Slides are the best media to promote interaction among students and between a teacher and students. This stimulates considerable interest by students, which is a key to motivation.

Nothing motivates like success, and nothing inhibits like failure. Therefore, the IPDE process is broken down into component parts that are easier to understand and master. This allows for dominant strands of knowledge to be introduced early into the unit and then be reinforced throughout the sessions. The path of travel concept is a good example. Then, along with the learning of such concepts, positive feelings and values can be nurtured which in turn leads to the development of proper attitudes toward the course and traffic safety in general.

The key to safe driving consists of making proper responses, in terms of space and time, to the ever-changing system situations. So, most sessions are organized around the responses to common situations and the thought processes that apply. The traditional approach of presenting information under the environmental settings of city driving, highway driving, and freeway driving is inconsistent with the mental demands of the driving task. Most traffic factors or situations may arise at any time or at any place on the highway.

Session One introduces the nature of the perceptual process and how it applies to the driving task. Three general perceptual habits are identified which serve as the basis for developing succeeding sessions. This session corresponds to a textbook chapter introducing the IPDE process.

Sessions Two through Five provide students with efficient visual habits for "where to search" and "what to search for." These identification habits along with the basic concepts of traction, space, and visibility are applied and evaluated. The four sessions correspond to the textbook chapters on driving environments.

Session Six provides students with guidelines for analyzing and interpreting what they have perceived in the traffic scene. This serves as a basis for predicting the actions of other users and the identification of conflict probabilities. Training exercises are conducted with the use of case study diagrams and traffic scenes.

Session Seven provides students with guidelines for making proper responses to problem traffic situations. It ties together the mental skills of identifying, evaluating, and deciding into one overall habit pattern. The focus is on timing, positioning, and communication. Problem situations are provided for applications and feedback. Textbook chapters on interacting with other traffic can be used as reading assignments for both Sessions Six and Seven.

Scheduling Sessions

When scheduling this unit, it might best be taught when students are most motivated to learn and participate. This would be when the majority of the students have received or are about to receive their learner's permits.

The time needed will vary with the amount of discussion that occurs with the training transparencies and traffic slides. The time needed will also depend upon the length of the classroom sessions. The suggested schedule for all seven sessions is:

- Session One: Improving Perceptual Skills
 - One to two class periods
- Session Two: Identifying Traffic Controls
 - Two class periods
- Session Three: Identifying Highway Conditions
 - One to two class periods
- Session Four: Identifying Other User Actions
 - One to two class periods
- Session Five: Identifying All HTS Events
 - One class period
- Session Six: Identifying Conflict Probabilities
 - One to two class periods
- Session Seven: Responding to Problem Situations
 - One to two class periods

It may be best to schedule Session Two on traffic controls into a unit on traffic laws. The other six sessions should be presented in the order provided. This allows each major group of events (controls, highway, and other users) to be introduced separately and prevents overtaxing the student's perceptual abilities and allows for more efficient instruction. In the beginning, a novice cannot be expected to cope with the entire range of events found in many driving situations.

With a comprehensive set of slides, the unit can be easily implemented into any local school program. Sufficient flexibility is built in to enable each session to be condensed or expanded to meet local needs. Slides of local traffic situations can be added, if desired. Video-taping of local environments can also supplement this unit.

Terminology

The terminology has been simplified by the elimination of such terms as minimize, separate, compromise and stabilize which were introduced along with the IPDE process. These terms describe actions that produce changes in vehicle timing and positioning. Thus, simply by focusing on "timing" and "positioning," we encompass the concepts behind these terms and eliminate the need for students to memorize unnecessary terms.

Some terms have been altered for clarification. For example, "space margin" is used instead of space cushion since the concept is easier to apply and measure. The term "conflict probabilities" was chosen, because its limits are less than such terms as possible, potential, or immediate. "Probable" refers to things that are more likely to happen and; therefore, should command a driver's attention. Use of the term "conflict probability" also serves as a method of measuring the seriousness of a hazard and provides students with good evidence for arriving at a more reliable prediction.

Finally, the idea of having a "plan of action" replaces the negative concept of defensive driving. This allows the teaching of a more positive mental framework, that of planning ahead and being prepared. "Expect the unexpected" is a catchy phrase that has little or no application. "Expect other user errors and be prepared" is a more measurable guide. It is hoped this approach will produce drivers who are active seekers and copers, rather than defenders or passive acceptors.

Guidelines for Use of the Script

The detailed script is provided so that a minimum of preparation is required by both the novice and experienced teacher. It also provides for better coordination between two or more staff members. The questions and script for the flash-slide activities should be followed more or less verbatim. The rest of the script should be considered as a suggested guide. However, a close adherence to the script the first few times will ensure proper pacing and the inclusion of important concepts.

Students learn more effectively if they know the objectives and are shown how to gain those ends. Therefore, each session begins with a brief introduction, which includes the session objective.

It is especially important to establish a friendly and informal atmosphere where group discussion can easily take place. Discussing and analyzing traffic situations enables each student to profit from the pooled experiences of the whole group. Since we are unlikely to change most student's view just by lecturing, we must stimulate them to do some thinking. One of the best ways of doing this is by having them "think aloud." As a result, there is a good chance students will develop better attitudes both toward their own perceptual skill improvement and toward traffic safety in general.

During group discussions, try to guide the group to be as specific as possible. Urge class members to cite personal experiences. When a question is asked, refer it to the whole group for consideration. There is a better chance for peer approval to take place.

The script for each session is in large type. Suggestions to the teacher are in small type and are usually placed in the left-hand margin. Teachers are encouraged to add their own notes and to highlight the main points.

Use of introductory Masters

A number of illustrated masters are provided for each session to help introduce basic concepts, definitions, and principles. Transparencies can be made from these masters or they can be put into a Power Point Program. They should be used to stimulate discussion and assess class readiness for the rest of the session. To be successful with the flash-slide and case study activities, students must have a good knowledge of the definitions and the concepts used. The introductory masters are lettered so as to be distinguished from the training slides.

For an effective presentation, the introductory masters should be shown in a normally lighted room with the instructor facing the class. The on and off switch can be used to direct attention to the instructor or the screen. A pointer may be used to identify something specific on the picture or diagram. It is important to talk to the group rather than to the screen.

Teachers can achieve better results if the initial use of a projector and reading aloud of the script is rehearsed. After one or two rehearsals and a class presentation, the teacher should try to instruct without close reliance on the script. It is recommended that the teacher eventually be able to teach from the introductory masters.

Flash-Slide Projection Guidelines

Four sets of slides, with traffic scenes shown from the driver's point of view, are provided for Session Two through Five. The slides are designed to help the students apply principles and definitions in realistic settings under the pressure of time. These flash-slides must be shown in a completely darkened room.

When placing the flash-slides in a projector tray for sessions two, three, four and five; place the first three slides in the tray and then place a blank slide after the remaining slides, four through ten. The blank slide will light the room for students to respond to the three questions. Each slide should be exposed for a good five seconds. This time can be monitored with a stop watch or by counting one-thousand-one, two-thousand-two, etc. for each second. It is important that class members believe they are provided with ample time. If some complain about the lack of time, it can be explained, that in a moving vehicle, a driver has only three or four seconds to perceive something in one area before looking to another part of the scene.

The first two slides in sessions 2, 3, 4 and 5 are to be used for demonstration purposes. Leave the picture on the screen while the questions are asked and discussed. For the other slides in each set, the three true-false questions are to be asked after the slide is flashed off. The traffic scene is then shown again for scoring. The questions, with the correct answers, are provided in the script. An answer sheet, which must be duplicated, is located in the Appendix.

In order to obtain the best results with the flash-slide training, the class should be motivated from the beginning. Each individual should be given a realistic expectancy for improvement no

matter how good he or she is at the outset. This reinforces the sureness of perception without building up one's overconfidence.

Case Study Slides

A variety of case study slides are provided for use in Session Six and Seven. These slides are to be shown on the screen for as long as necessary, usually in a normally lighted room. Additional diagrams of traffic cases are provided to use in small group discussions or as assignments for homework. The masters for these cases are located in the Appendix.

Since the case study method simulates real life situations, students can easily identify with the problems and want to become involved. When the method is used properly, students not only learn the best responses for certain situations, but they also learn the mental processes or thought patterns to use for coping with similar traffic situations.

Evaluation of Student Achievement

Formative and summative evaluation is built into the program. Formative evaluation as used here consists of those measures and judgments that are provided to students during the training period. To do this, immediate feedback is given after each practice slide along with appropriate discussion when necessary.

Summative evaluations are provided at the end of each set of slides. They seek to determine if the students have achieved the session objectives and to what level of proficiency. Checklists are also provided for in-car evaluation.

Transfer of Training

The great variety of traffic situations that drivers will encounter, have been classified into a few major categories. This provides a broader type of learning experience and the transfer of training. The students, both during and after the course, can develop better ability to cope with new situations.

When practical, selected films or video tapes can be used similar to the flash-slide method. Certain segments of a film can be run for about five seconds, and then stopped for three true-false questions. In this way, learning can be transferred from the static traffic situations to dynamic situations. This should then make the transfer of training to the car easier.

By using the check sheets provided in the Appendix, the training that is being conducted in the classroom can be transferred easily to the laboratory on-street experiences. However, this will require the careful selection of BTW routes and the proper use of the commentary driving method. Remember that transfer of training is not automatic. There must be guidance by the teacher.

Room Arrangement and Equipment

The presentation of the program should be in a room that can be darkened effectively for the flash-slide presentation. The chairs should be so arranged that class members have a clear view and will be a proper viewing distance from the screen. Finally, the slide projector should be located and adjusted so that the image almost fills the screen.

The following equipment is recommended:

- Projection screen 60 or 70 inches wide
- 35 mm slide projector
- Remote control for advancing slides
- Shaded reading light or flashlight
- Stop watch or other timing device
- Pointer
- Spare projector bulb
- VCR and monitor
- Overhead projector or projector for Power Point
- Computer: Presentation software

Perceptual Driving Program

Teaching Point	Rationale
The rationale should be presented to the students before session one. It prepares the students for the perceptual driving program.	<p>Every action we take with our motor vehicle is determined by what we identify and process in our brain. The actions we are referring to are speed selection, position and/or direction selection and communication selection. As drivers, we are constantly adjusting our speed, position and communicating, and this is all determined by what we identify and evaluate. Identifying is done with all of our senses, but in driving, it is primarily done with our eyes.</p> <p>The average driver who is involved in a collision will usually indicate with one of three responses as to why the collision occurred and these are:</p>
Show G-A Master. Show each reason as it is discussed.	<p>"I didn't see him;" "I didn't see him in time;" and "I didn't think he would do what he did."</p> <p>These three statements indicate most drivers do not know how to use their eyes in an effective manner. and they do not know what to search for in an orderly manner.</p>
Show G-B Master. Show each goal as it is presented.	<p>The overall goals of this program are:</p> <ol style="list-style-type: none"> 1. Learn effective and efficient perceptual driving skills. 2. Learn how to make proper responses to problem traffic situations once they are identified and evaluated.
Show G-C Master.	<p>You will become a lower risk driver, if you apply and practice the concepts that will be taught in this program. A lower risk driver can be defined as:</p>

Teaching Point	Rationale
	"A driver who identifies real and/or potential hazards and reduces the risk of these hazards by adjusting speed and/or position and communicates to others his/her intentions."
Show G-D Master. Show each session as it is presented.	This program is divided into seven sessions: <ol style="list-style-type: none"> 1. Improving Perceptual Skills 2. Identifying Traffic Controls 3. Identifying Highway Conditions 4. Identifying Other User Actions 5. Identifying All HTS Events 6. Identifying and Evaluating Conflict Probabilities 7. Responding to Problem Situations
Introduce the latest crash data involving the 16- & 17-year-old driver. The information to perform these maneuvers correctly is addressed throughout Module III. The crash data needs to be emphasized as you teach the perception and driving strategy and involve the students in the suggested activities of each lesson.	Teenage drivers are over represented in crashes involving the following types of driving maneuvers. <ul style="list-style-type: none"> • Driving on wet pavements. • Driving with passengers causing distractions. • Pulling out from a stop sign. • Turning left across traffic. • Maintaining a safe distance between vehicles. • Negotiating highway curves day and night. • Maintaining vehicle control (effects of speeding). • Changing lanes and passing. <p>Note: Students need to know the latest crash data involving their age groups and to be instructed how to perform these driving maneuvers in a safe manner.</p>

Stated Reasons for Collision

- "I didn't see him"
- "I didn't see him in time"
- "I didn't think he would do it"

Overall Goals of Program

1. Learn effective and efficient perceptual driving skills
2. Learn how to make proper responses to problem traffic situations once they are identified and evaluated

Definition of a Low Risk Driver

"A driver who identifies real and/or potential hazards and reduces the risk of these hazards by adjusting speed and/or position and communicates to others his/her intentions."

Perceptual Driving Program Sessions

1. Improving Perceptual Skills
2. Identifying Traffic Controls
3. Identifying Highway Conditions
4. Identifying Other User Actions
5. Identifying All HTS Events
6. Identifying and Evaluating Conflict Probabilities
7. Responding to Problem Situations

Session One: Improving Perceptual Skills

Session Objectives

1. Students will identify those parts of the Highway Transportation System that must be quickly perceived.
2. Students can define perception as a mental process that is selective and can be improved.
3. Students will define the concept "Projected Path of Travel."
4. Students can identify three general habits for improving a driver's perceptual skills.
5. Students can list the eye habits for vehicle control and selective scanning of the traffic scene; they can state at least three errors drivers make when not using good scanning habits.

Session Outline

1. Introduction
2. Nature of Perception
 - a. Involves Senses and Brain
 - b. Must be Selective Process
 - c. Can be Improved with Directed Practice
 - d. Factors Affecting Perception
3. Habits for Improving Driver Perception
 - a. Use Efficient Scanning Habits
 - b. Use a Systematic Search Pattern
 - c. Search for Conflict Situations
4. Eye Habits for Vehicle Control
 - a. Picture Intended Path of Travel
 - b. Look Down Middle of Path
 - c. Look Far Ahead
 - d. Common Errors
5. Searching Habits for Identification
 - a. Search Scene Ahead and to Sides
 - b. Search Road Surface
 - c. Search Mirrors and Dash
 - d. Common Errors
6. Session Quiz
7. Session Summary

Time:

Minimum one class period and maximum two class periods.

Purpose:

This session introduces the nature of perception and how it applies to the driving task. Visual habits contribute to driving in two ways: maintaining control of the vehicle and identifying critical elements in the traffic environment. Vision is a skill, and this session begins to demonstrate how this skill can be practiced in a planned manner and not a haphazard manner. Because of the nature of this session, certain pages of the driver education text should be identified and used as a resource to reinforce or supplement the information in this session. Parts of the driver education texts that would be most appropriate are:

1. The Highway Transportation System
2. The IPDE Process
3. The Smith System
4. Factors Affecting Driving

A short video, "Using Your Eyes Effectively," (AAA) will reinforce all or most of the objectives addressed in Session One. It is recommended that this video be used at the end of Session One.

Materials/Equipment:

- Perceptual Driving Program, Session One
- Driver Education Text
- Overhead Projector or Power Point
- Screen
- Chalkboard
- Selective Worksheets
- VCR/Monitor
- "Using Your Eyes Effectively" Video from AAA (recommended)
- CD Rom -Module III, Perception and Driving Strategies for Different Environments
- Computer with CD capability and LCD Projector

Teaching Point	Rationale
Show P-A Master. Uncover each objective as it is introduced.	Introduction to Session In Session One, you will be expected to be able to demonstrate the following: <ol style="list-style-type: none">1. Identify those parts of the Highway Transportation System (HTS) that must be quickly perceived;2. Define perception as a mental process that is selective and can be improved;3. Define the concept "Projected Path of Travel";4. Identify the three general habits for improving perception of the HTS events;5. Identify three eye habits for car control and common errors associated with poor eye habits; and

Teaching Point	Rationale
	<p>6. Identify three eye habits for searching the traffic scene and common errors associated with poor searching habits.</p>
<p>Show P-B Master. Show each event as it is discussed.</p>	<p>The HTS is complex, because it is made up of many parts or elements. These many different parts interact with each other which results in a variety of traffic situations or problems. The HTS is also complex because of the many changes that constantly take place in the highway and traffic conditions. Highways are of different widths and have a few different road surfaces. There can be increases or decreases in traction and visibility. Traffic conditions are changing because of the numbers and kinds of vehicles present as well as the variations in speed.</p> <p>Here is a brief overview of what drivers must perceive quickly in the complex HTS.</p>
<p>Own Motor Vehicle</p>	<ul style="list-style-type: none"> • Each has its own set of handling characteristics, (steering, accelerating, braking, suspension) and a number of accessories. • They vary in width, length, and height. A number of engine sizes, transmissions, safety devices and other options are available. • Have class give more examples.
<p>Highways</p>	<ul style="list-style-type: none"> • There are almost four million miles of highways linking together all parts of our country. They range from multi-lined freeways to dirt roads. • As perceptive drivers, we must identify all roadway conditions in advance and make proper allowances. • Have class give more examples.
<p>Unrelated Events</p>	<ul style="list-style-type: none"> • Many unrelated events can distract the driver from observing the more important occurrences affecting the path of travel. • A driver's attention should be given to such events only when traffic is light. • Have class give more examples.
<p>Traffic Controls</p>	<ul style="list-style-type: none"> • Any complex system must have a set of controls if it is to be operated safely and efficiently. • A variety of signs, signals, and markings are provided to regulate, warn and guide traffic. These are evaluated and changed, so we must keep up-to-date. • Have class give more examples.
<p>Other Users</p>	<ul style="list-style-type: none"> • Almost everyone uses the HTS - as passengers, drivers, pedestrians, joggers or bicyclists. • There are over 160 million persons licensed to drive. Each has different goals and personal traits. • There are more than 170 million registered motor vehicles of varying size, performance capability, kind and condition.

Teaching Point	Rationale
	<p>As you can see, the HTS is truly a dynamic and complex system. As a result, driving involves the constant observation and analysis of many things in the traffic scene. You must also realize that as a driver, you will have only a limited amount of time to perceive these events.</p> <p>Unfortunately, many drivers have collisions because they have not learned how to use their eyes in an efficient manner. Nor do they know what to search for in an orderly way. Their perceptual skills are just not good enough for today's traffic problems.</p>
Show P-C Master. Show each point as it is discussed.	<p>Nature of Perception</p> <p>Perception is an ongoing process that involves a number of mental operations such as associating, comparing and matching. It can be done skillfully or haphazardly.</p>
Awareness needs to be emphasized.	<p>Involves our Senses and Brain</p> <p>Awareness is the first step in the process of perception. We can't identify something of which we are not aware. To become aware of something means we must not only observe it, we must also give attention to it. A driver is usually aware of traffic controls such as stop signs, traffic lights, and posted speed signs and they are easily identified. Traffic controls that are not so easily identified are warning signs. Drivers see the warning sign, but they do not identify it. We become aware of things through our senses.</p>
Have the students list how these senses bring information to the brain.	<ul style="list-style-type: none"> • The senses bring information to the brain about what is happening around us. The brain then processes the information. The primary senses in driving that bring information to the brain for processing are: sight, feel, hear, and smell. • Incoming information (data or input) is changed into something meaningful. Then we say, "Oh, now I see," or "I understand," or "Now I know what you mean." So, it is the mind that does the seeing or perceiving. For example, we become aware of a four legged and hairy animal through our senses. If the tail is wagging, we then identify the dog as friendly. • To be a safe driver, you must not only be able to observe things quickly, you must also be able to identify or recognize what was observed.
Uncover second point.	<p>Takes Time -Must be Selective Process</p> <ul style="list-style-type: none"> • Our eyes and other senses can send more information to the brain than the brain can attend to in a moment. • You can only identify and process one thing at a time. Those items that are familiar can be identified rather quickly versus something that is not familiar will take longer to identify and process.

Teaching Point	Rationale
	<ul style="list-style-type: none"> Identifying something is done with two parts of your vision. The one part is peripheral-vision and the second part is central vision. The latter is no more than 10 degrees of your vision and you primarily use this part to identify and read. The first part is peripheral and this is your field of vision on either side of central vision. What you see with this vision is size, color and movement. Many times, something seen in this vision will cause you to direct your central vision at the object. It takes the mind time to process the incoming information-to organize it, classify it and make it meaningful. In a moving vehicle, time is limited. Therefore, our perception of the traffic scene must be a selective process. We must choose what we will attend to and perceive.
Uncover third point.	<p>Can be Improved with Directed Practice</p> <ul style="list-style-type: none"> We perceive in order to learn, but we can also learn to improve the perceptual process itself. Powers of observation develop as they are trained and used in a directed way. No matter how well we think. we can perceive, perceptions improve with training and practice.
Use blank screen.	<p>Factors Affecting Perception</p> <ul style="list-style-type: none"> Even an expert has problems if the body is not kept in good physical condition. Perceptions are affected by health, fatigue, drugs and emotions. What our mind selects to process at a given moment depends on our goals or what is important to us.
Show P-D master	<p>The Path of Travel Concept</p> <ul style="list-style-type: none"> The act of driving consists of controlling and guiding a car safely from one place to another along a selected pathway, with other traffic, on a complex network of highways. This path of travel is that strip of roadway that is wide enough and long enough to permit the safe forward movement of the automobile. When conditions permit, the projected path of travel should be 20 to 30 seconds in front.
Speed and stopping distance are main factors.	<ul style="list-style-type: none"> The safe driver is one who selects and maintains a clear path of travel at all times. To do-this requires the perception of those events taking place along the projected path of travel. This is a key concept to learn and apply in all these lessons.
Show P-E master.	<p>Habits for Improving Perception</p>
Show each habit as it is discussed.	<p>There are three habits that will help you improve your ability to perceive traffic events. They will form the basis for practice in other sessions.</p> <p>As a young person, you may already do well at perceiving things around you. Our goal is to help you improve that skill.</p>

Teaching Point	Rationale
Show first habit.	<p>Use Efficient Eye Habits</p> <ul style="list-style-type: none"> Your actions in traffic are mostly the result of two factors: how you use your eyes and the meaning you take from what you see. How to look. Eye habits give you confidence; they will help you reduce mental and physical strain.
Show second habit.	<p>Use a Systematic Search Pattern</p> <ul style="list-style-type: none"> When there are many things to observe, it is best to deal with them in a few meaningful groups. This aids in the selection process and helps ensure that you do not overlook important clues. We will classify all things into three major groups. We will search first for Traffic Controls, second for Highway Conditions and third for Other Users. The reason that traffic controls are first, they are well located, easy to identify and universal meaning. If we are mentally "set" for something, we require less time to perceive it, and we tend to stay alert. Where and what to look for.
Show third habit.	<p>Search for Conflict Situations</p> <ul style="list-style-type: none"> Your projected path of travel is the basic point of reference in the selection of what to perceive as well as for the guidance of your vehicle. Your primary search must be for those hazards or other user movements that could result in a conflict within your path of travel. Anything not related to your path of travel should be passed over quickly. Then, you will not be distracted from perceiving the critical events. A key question you should start asking yourself is: "Will my travel path be clear for 20 to 30 seconds ahead?"
Emphasize this point.	<p>Know Where to Look and What to Look for</p> <ul style="list-style-type: none"> These three habits for improving perceptions will result in your knowing what to look for- the real key to the selection process. This is because you will develop a mental "set" for observing what's important. As you practice these habits, it will help to ask yourself three questions: "What is it?" "Where is it?" and "What is it doing?"
Show P-F Master.	<p>Eye Habits for Vehicle Control</p> <p>I will provide you with some guidelines for improving your eye habits for vehicle control. Remember these when you practice in the training car. First, let's consider how best to use your eyes for vehicle control. They are basic to the development of effective scanning habits.</p>
Show first habit.	Picture Intended Path of Travel

Teaching Point	Rationale
	<ul style="list-style-type: none"> You need to define a safe path of travel toward which to steer. Therefore, you should get a good picture in your mind of where you intend to go. Imagine a pathway the width of your vehicle, stretching out ahead of you. It should be wide enough and long enough to permit the safe movement of your car.
Show second habit.	<p>Look Down Middle of Path</p> <ul style="list-style-type: none"> Guide your vehicle along an imaginary line down the middle of your intended path of travel. We tend to steer where we look. Thus drivers, who use the right edge of the roadway or the center line as a main point of reference, usually end up with poor lane positioning and low-aim steering. You can use these as a quick reference for your lane position, but you should always get your eyes back to the center of the path.
Show third habit.	<p>Look Far Ahead</p> <ul style="list-style-type: none"> Have a visual lead of at least twenty to thirty seconds when conditions permit it. You need space and time for controlling your vehicle and for making decisions.
Blank screen.	<p>Poor Eye Habits lead to these common errors:</p> <ul style="list-style-type: none"> Making wide swings on right turns. Cutting left turns; Sitting on edge of seat. Making hard stops or turns; Not maintaining a consistent lane position. Steering is erratic at higher speeds; Boxed in behind large or slow-moving vehicles; Not noticing traffic tie-ups in advance; and Frequently encountering unpleasant surprises.
For Teacher Use Only.	<p>Important Teaching Points</p> <ul style="list-style-type: none"> New drivers have a tendency to look only a short distance in front of the vehicle. In fact, new drivers will attempt to get as close as possible to the steering wheel because they want to see what is immediately in front of the vehicle. This is a good clue of their short sight distance. It is all right to check the lane position of the vehicle by aligning a reference part of the vehicle with the right lane line, but this is only a quick check and not to continuously focus on this reference point. When going through a curve, a driver will have a tendency to focus their eyes close to the car; and the eyes should be looking through the curve as much as possible. A quick lane position check can be done with the lane line, but the eyes need to get back to the projected path of travel. A student walking in the hallway with their eyes down will suddenly flinch when another person suddenly appears in their short sight distance; a driver with a short sight distance will also flinch with the steering wheel

Teaching Point	Rationale
	<p>when a large vehicle, such as a truck, suddenly comes into their short sight distance. At low speeds of 20 to 25 mph, this is not so noticeable, but as the speed increases, 30 mph or greater, the short sight distance will play havoc in controlling the vehicle's lane position.</p> <ul style="list-style-type: none"> • Review the second on-street lesson plan relating to sight distance. • Remember that for most drivers, their eyes will fail them in sudden emergencies, e.g., when entering a curve too fast, their sight distance will shrink, and their eyes will focus on the inside of the curve. When attempting to avoid a collision, their eyes will stare at the collision and not look through it. When encountering a sudden rear wheel skid, their sight distance will shrink, and their eyes will focus immediately on the front of the car, making it more difficult to recover from a skid. All of these failures result in a greater risk of having a collision or losing control of the vehicle.
<p>Show P-G Master for first habit. Note how path of travel becomes key point from which to guide, scan and search for relevant events.</p>	<p>Searching Habits for Identification</p> <p>To the eye habits for guiding your car, we will add the searching habits for identification. Searching is the ability to observe the whole traffic scene in a very short time. We can focus our attention on only one thing at a time for perceiving, but we can shift our eyes quickly from one event to another. Constant searching helps prevent both fixed and blank stares; it also reduces fatigue and helps us resist the many distractions. Search the Scene Ahead and to Sides</p> <ul style="list-style-type: none"> • This is the first visual habit to improve your identification skills. • Look up and down your travel path. When behind cars, look over and around them to the second and third vehicles ahead. When behind trucks, move to one side of the lane for a better view ahead. The key is to search out as far as possible and to identify those clues which enable the driver to make safe and efficient decisions. • Search from side to side by moving your eyes from the center of the intended path to other areas and back again. Make these quick looks. • At night, look at the far edge of the lighted area rather than the center of such area. • Use special search patterns at intersections, interchanges and areas of less space or visibility.
<p>Show P-H Master for second habit.</p>	<p>Search the Road Surface</p> <ul style="list-style-type: none"> • This is the second visual habit to improve your identification skills. • Using quick glances, watch the road surface for the pavement markings and changes in width or conditions.

Teaching Point	Rationale
	<ul style="list-style-type: none"> • Make a habit of observing the pavement under parked cars for clues to pedestrian actions. • Observe the pavement beside a moving car to help judge its speed or changes in direction. • The road surface provides a good reference point in relation to determining the speed and position of other vehicles. • Be sure not to focus your attention too long on any one area. If something is identified as a potential conflict, the driver needs to pay more attention to it; but, the driver cannot afford to stare at it. The driver needs to frequent their glances at the potential problem but still be aware of anything else that might affect their projected path of travel.
Show P-I Master for third habit.	<p>Scan the Mirrors and Dash</p> <ul style="list-style-type: none"> • This is the third visual habit to improve your identification skills. • Check your mirrors the instant you observe a conflict ahead. Also, see if your signals are being heeded. • Make these checks at least every five seconds in urban areas and every ten seconds in rural areas.
Especially important habit for freeway to help maintain alertness.	<ul style="list-style-type: none"> • Time these checks in keeping with traffic conditions. Attend to critical areas first and more frequently. • Some specific times for mirror checks are: any type of lane change (there are many), approaching an intersection, after exiting an intersection, and when anticipating a speed or position adjustment. There are also suggested times for panel or dash checks, and this is especially needed for new drivers in monitoring their speed.
Blank screen.	Common Errors made by drivers with poor scanning habits:
May ask for explanations.	<ul style="list-style-type: none"> • Does not react to problems promptly; • Fails to maintain space margins; • Has frequent near misses; is not aware of own speed; • Is not aware of vehicle about to pass; • Is easily distracted and fatigued; • Drives with signals flashing when not needed; and • Drives with fogged or partially blocked windows.

Session Summary

- Since driving takes place in a complex highway transportation-system, there are many things to perceive in a limited amount of time.
- Perception of the traffic scene must, therefore, be a selective process.
- To be selective, drivers must know where and what to search for; they must be systematic in their searching.
- No matter how perceptive we are, we can improve.

- Eye habits for vehicle control are:
 1. Picture the intended path of travel;
 2. Look down the middle of the path; and
 3. Look far ahead.
- Searching habits for identification are:
 1. Search the scene ahead and to both sides
 2. Search the road surface
 3. Search the mirrors and dash
- Good visual habits help you stay alert and avoid errors. They make driving easier and more enjoyable.
- An excellent resource that does a good job of reinforcing or summarizing what you just taught is the AAA video "Using Your Eyes Effectively." Most of the objectives are summarized rather well with this short video.

Session One Quiz

You can use this quiz as a review for the students to see if they have accomplished the objectives. The correct answer is checked.

1. In what kind of a system does driving take place?
 - a. Simple
 - b. Uncomplicated
 - c. Complex
2. We become aware of things around us through our?
 - a. Brain
 - b. Senses
 - c. Nerves
3. In a given period of time, the mind can receive and process:
 - a. Less information than the eyes can send to it
 - b. More information than the eyes can send to it
 - c. About the same amount of information as the eyes send it
4. Our perceptual abilities:
 - a. Remain the same with or without training
 - b. Cannot be improved with training
 - c. Can be improved with training
5. Which of these habits is the real key to selection process?
 - a. Use efficient scanning habits
 - b. Use a systematic search pattern
 - c. Search for closing movements
6. What scanning habit will help you most in judging the speed and possible changes in the direction of other cars?
 - a. Search the scene ahead and to the sides
 - b. Search the mirrors and dash
 - c. Search the road surface
7. What scanning habit will help you most if you are not reacting promptly to traffic problems?
 - a. Search the scene ahead and to the sides
 - b. Search the mirrors and dash
 - c. Search the road surface
8. What scanning habit will help you most if you are not usually aware of cars about to pass?
 - a. Search the scene ahead and to the sides
 - b. Search the mirrors and dash
 - c. Search the road surface

Session One Objectives

- Identify those parts of the Highway Transportation System (HTS) that must be quickly perceived
- Define perception as a mental process that is selective and can be improved
- Define the concept "Projected Path of Travel"
- Identify the three general habits for improving perception of the HTS events
- Identify three eye habits for car control and common errors associated with poor eye habits
- Identify three eye habits for searching the traffic scene and common errors associated with poor searching habits



Our Complex Highway Transportation System

Own Vehicle

- Gauges
- Sounds
- Motions

Highway

- Roadway
- Shoulders
- Obstructions

Unrelated

- Music
- Scenic Views
- Advertisements

Traffic Controls

- Markings
- Signs and Signals
- Other Laws

Other Users

- Vehicles/Drivers
- Pedestrians
- Bicyclists

Nature of Perception

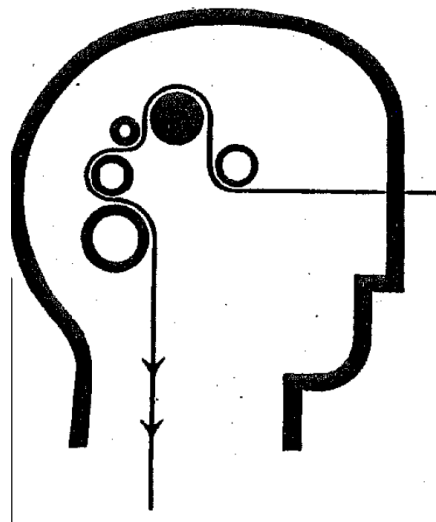

- Involves our Senses and Brain
- Takes Time -- Must Be Selective Process
- Can Be Improved with Directed Practice

Projected Path of Travel

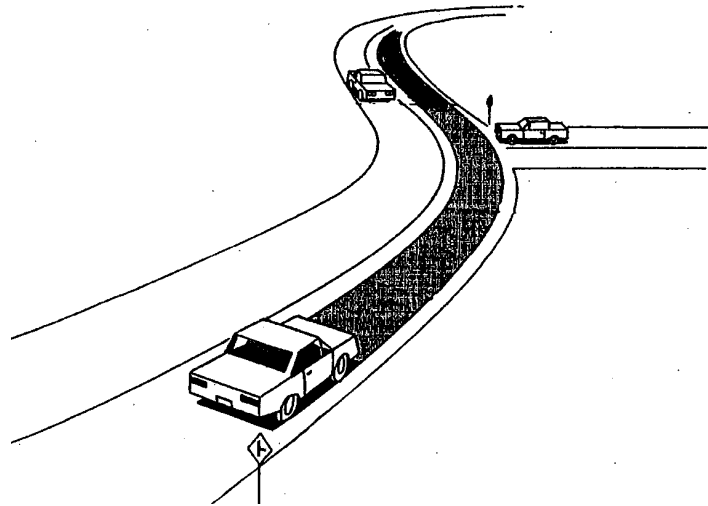

Habits for Improving Perception

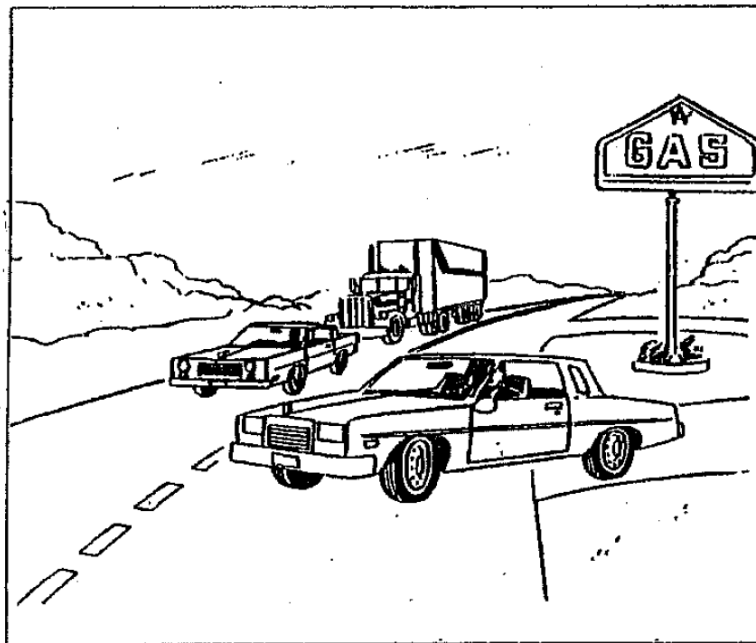

- Use Efficient Eye Habits
- Use Systematic Search Pattern
- Search for Conflict Situations

Know what to look for!

Eye Habits for Vehicle Control

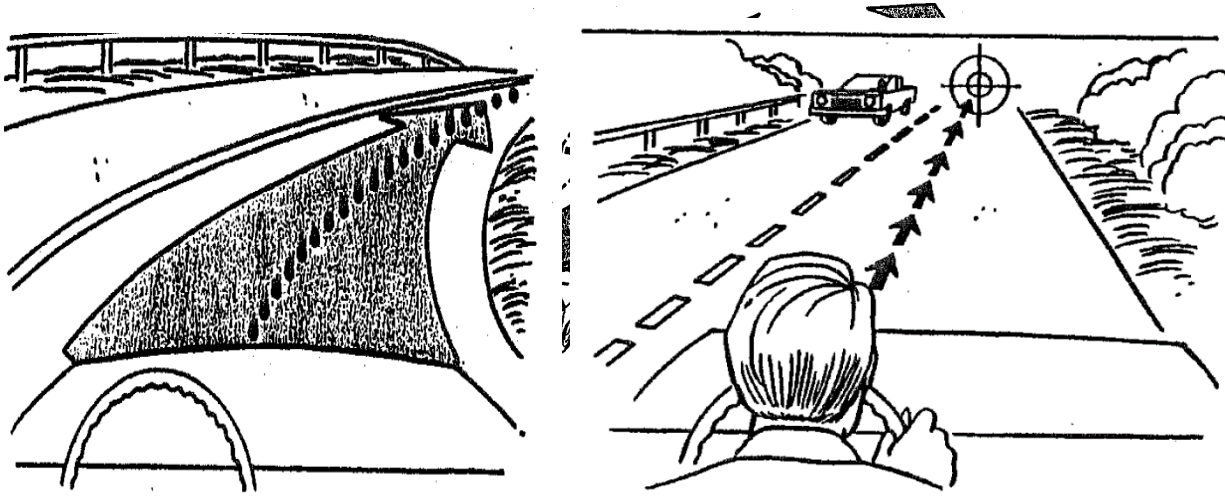

- Picture Path of Travel
- Look Down Middle
- Look Far Ahead

Search the Scene Ahead

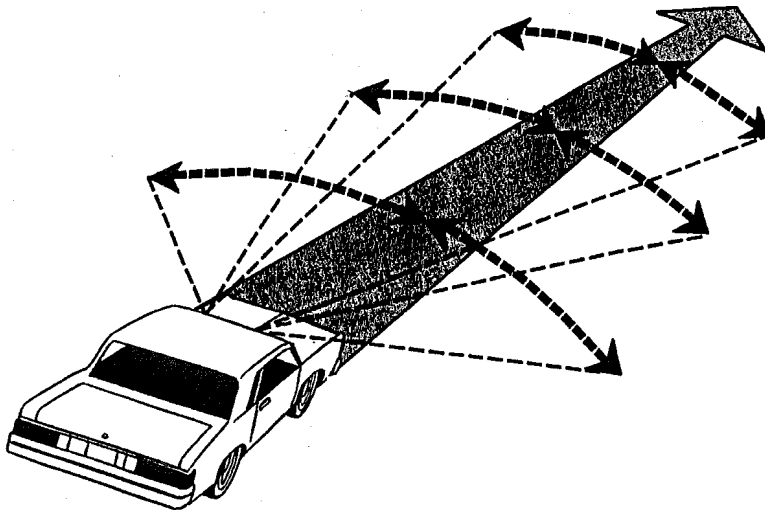

- Search 20 to 30 Seconds Ahead
- Search from Side to Side

Search the Road Surface

- To Detect Changes in Direction
- To Assess Speed of Other Cars
- To Check for Pedestrians Between Parked Cars

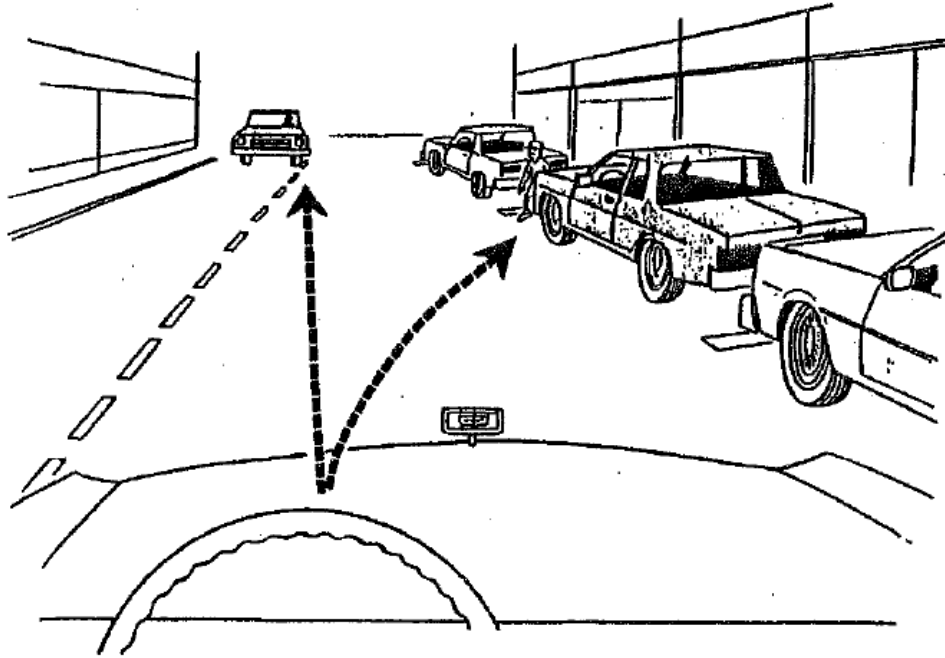

Search Mirrors and Dash

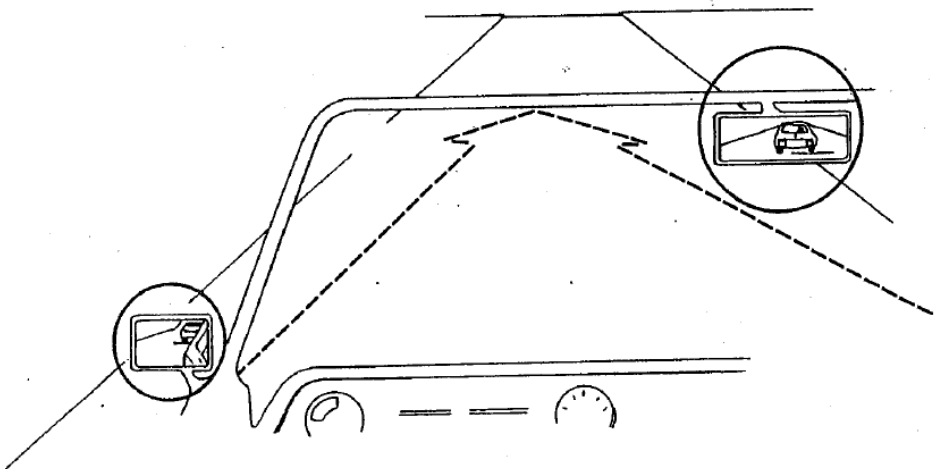

- Check Inside and Outside Mirrors
- Check Dash Regularly

Session Two: Identifying Traffic Controls

Time:

Minimum of two class periods.

Purpose:

When learning a systematic search pattern, the first category to identify is traffic controls. Traffic controls are easy to see and they have universal meaning. In other words, traffic controls are "static," a driver can easily identify the control and predict what it means as it relates to one's projected path of travel and what is expected of the other highway users. Traffic controls perform various functions and it is important that the beginning driver identifies and understands these functions. The driver education text and the Pennsylvania Driver's Manual should serve as a resource for this session, and the most appropriate parts are:

1. Signs, Signals, and Markings
2. Rules of the Road

A source that will reinforce this session is the video, "Are You Reading Me?" This video is available from AAA; and if it is used, or one similar, it should be shown before doing the flash-slide activity.

Materials/Equipment:

- Perceptual Driving Program, Session Two
- Driver Education Text Pennsylvania Driver's Manual Pennsylvania Vehicle Code
- Video "Are You Reading Me?" or one similar
- Overhead Projector or Power Point
- Computer and presentation software
- Selective Worksheets
- Screen
- VCR/Monitor
- CD Rom -Module III, Perception and Driving Strategies for Different Environments
- Computer with CD capability and LCD Projector

Session Objectives:

1. Students can identify regulatory signs and their respective meanings by the color, shape and symbol;
2. Students can identify warning signs and their respective meanings by the color, shape and symbol;
3. Students can identify guide signs and their respective meanings by the color, shape, symbol and numbering;
4. Students can identify construction signs and their respective meanings by the color, shape and symbol;

5. Students can identify the various traffic light signals and their respective meanings;
6. Students can identify the various lane markings and their respective meanings; and
7. When exposed to a HTS situation on a screen for five seconds or less, students can identify the signs, signals and pavement markings and the responsibilities for the driver and other highway users.

Session Outline:

1. Introduction
2. Traffic Sign Shapes, Colors, and Symbols
 - a. Regulatory Signs
 - b. Warning Signs
 - c. Guide Signs
 - d. Construction or Maintenance Signs
3. Traffic Control Signals
 - a. Standard Three-Light Controls
 - b. Controls with Arrows
 - c. Order in Which Lights Flash On and Off
 - d. Flashing Lights and Lane Signals
4. Pavement Markings
 - a. White Lines and Symbols
 - b. Yellow Lines
 - c. Illustrations of Situations
5. Flash-Slide Activity for Applications
 - a. Demonstration Slides
 - b. Practice Slides
 - c. Test Slides
6. Session Summary

Teaching Point	Rationale
Introduction to Session	<p>In this session, you will begin the development of the habit- a Systematic Search Pattern. Remember, this habit requires you to classify all the HTS events into three groups: (1) Traffic Controls; (2) Highway Conditions; and (3) Other Users.</p> <p>The first group you will practice searching for are Traffic Controls. Knowing what the traffic controls mean isn't enough. In a moving auto, you must be able to identify traffic controls well in advance and then respond properly. Therefore, our goal for this session is to be able to identify, within five seconds, the signs, signals, and pavement markings ahead. You can also indicate or tell the message intended for all the users present.</p>
Show C-A Master. Show each objective as it is presented.	<p>In session two, you will be expected to be able to demonstrate the following:</p> <ol style="list-style-type: none"> 1. Identify the various regulatory signs and their respective meanings;

Teaching Point	Rationale
	<ol style="list-style-type: none"> 2. Identify the various warning signs and their respective meanings; 3. Identify the various guide signs and their respective meanings; 4. Identify the various construction signs and their respective meanings; 5. Identify the various traffic signals and their respective meanings; and 6. Identify the various lane markings and their respective meanings. <p>To help you achieve these objectives, pictures of real traffic situations will be put on the screen. You will have only five seconds to search for and recognize the meanings of the traffic controls shown.</p> <p>Before this practice program begins, let's review the various kinds of traffic control devices. The meanings of these controls are shown by uniform shapes, colors and symbols. Once you know these, you can make your identifications quickly and correctly.</p>
Show C-B Master.	<p>Regulatory Signs</p> <p>General meaning - Regulatory signs inform a driver what must be done or what cannot be done. Drivers who fail to follow these directions are breaking a traffic law and can be cited.</p>
Emphasize to read the symbols from the bottom up.	<p>Colors and Shapes</p> <p>Background colors are red or white. Three of the shapes shown have one specific meaning and deal primarily with the right-of-way.</p> <ol style="list-style-type: none"> 1. red, eight-sided stop sign 2. red, triangular yield sign 3. red circle with white bar <p>The red, rectangular sign with the words "Wrong Way" may be used with or without the "Do Not Enter" sign. Most other regulatory signs are white and have a vertical rectangular shape such as (A). These include turning restriction, lane use, speed limit, parking, and pedestrian restriction signs. (Some may be square.)</p> <p>Specific Meanings Raise your hand for the correct answer. Look at sign "E." What is its meaning? <ol style="list-style-type: none"> A. exit to the right B. keep to the right (B is correct) C. divided highway ahead What is the meaning of sign "F"? <ol style="list-style-type: none"> A. one-way street to the right </p>

Teaching Point	Rationale
<p>Show C-C Master. Once again emphasize to read the symbols from the bottom up.</p>	<p>B. No turn on red C. no left turn (C is correct) Are there any questions about regulatory signs?</p> <p>Warning Signs</p> <p>General meaning-These signs warn a driver what to expect just ahead, such as roadway conditions, traffic or roadway changes. They should also trigger a visual search and perhaps a speed and position selection by the driver.</p> <p>Color and Shapes Warning signs are yellow and usually diamond shaped such as #1 in the illustration. There are four other shapes, each with a specific meaning.</p> <p>Meanings of Specific Signs What is the meaning of #2, the pennant-shaped sign? A. railroad ahead B. do not pass (B is correct) C. school zone ahead What is the meaning of #3, the five-sided sign? A. railroad ahead B. do not pass C. school zone ahead (C is correct) What is the meaning of #4, the round yellow sign? A. crossroad ahead B. railroad ahead (B is correct) C. do not enter What is the meaning of the red and orange triangular sign? A. Yield B. Construction C. slow-moving vehicle (C is correct) What is the difference between signs #7 and #8? What is the difference between signs #6 and #23? What is the difference between the yellow 35 mph sign in #13 and a white 35 mph sign? What is the difference between signs #16 and #17? Do both signs #15 and #18 warn of merging situations? Explain the difference. What is the meaning of sign #19? A. divided highway ahead B. two-way traffic ahead (B is correct) C. the highway divides What is the meaning of sign #21? A. winding road ahead B. rough road ahead C. slippery when wet (C is correct)</p>
<p>Show C-D Master.</p>	<p>Guide Signs</p> <p>General meaning- These signs provide the driver with</p>

Teaching Point	Rationale
	<p>directions to places and services and give other information that is not legally binding.</p> <p>Shapes Most guide signs have a horizontal rectangular shape. Route markers have different shapes for state, county, interstate and US highways.</p> <p>Colors and Meanings What color are the destination and mileage signs, #1-4? A. Blue B. Green C. Brown What color are the roadside services signs, #7-10? A. Blue B. Green C. Brown What color are the recreation area signs, #5 and #6? A. Blue B. Green C. Brown What is the color of sign #16? A. Blue B. Green C. Brown What direction do the even-numbered interstate routes go? A. East and west B. North and south What is the difference between route markers #11, #13 and #15?</p>
Important Teaching Points	<ul style="list-style-type: none"> • Under sign #1, the mileage is indicated to the center of the respective city or town. • Under sign #2, the mileage is indicated to the respective interchange or exit. When there is an Exit A and B, the intersecting highway is a divided highway and it is important to determine the direction you wish to travel on that respective highway. It is also important to look at what services are available at the respective exits. • Mileage markers always start either in the southern part of the state with north/south highways and in the western part of the state with east/west highways. • Interchanges can be identified with mile markers or consecutive numbering. • It is important to know the difference between a federal highway and a state highway, because the even and odd numbers will run east and west or north and south respectively with federal highways but not necessarily with state highways. • When an interstate highway has three numbers, it is important to identify whether the first number is even or

Teaching Point	Rationale
	<p>odd. If it is even, it is a beltway around the urban area, and it will eventually rejoin the two-digit interstate. If it is odd, it will not rejoin the original two-digit interstate, and it will end, requiring the need to select another route.</p> <ul style="list-style-type: none"> • If the interstate highway sign is green, it is a business interstate highway with cross traffic, and it will eventually rejoin the regular interstate highway.
Show blank screen.	<p>Construction Signs</p> <p>There is a fourth class of signs, called construction and maintenance signs. They warn drivers of temporary hazards ahead and of the presence of construction or roadway workers and slow-moving vehicles. These signs use the same shapes and symbols as most regulatory and warning signs. Their color is bright orange.</p> <p>Are there questions about any of the signs?</p>
Show C-E Master.	<p>Traffic Control Signals</p> <p>Signal lights are provided to control the traffic flow at certain locations. They also indicate who has the right-of-way. You should have a clear understanding of what each color and symbol means, and should know the order in which the lights flash off and on.</p> <p>Standard Three-Light Controls The standard signal control is shown in "E." The sequence of the lights is as follows: green with "walk," "walk" off and "don't walk" on; green off and yellow on; yellow off and red on; red off and green with "walk" on. The "walk" lights may flash briefly to indicate that the change is coming.</p> <p>Signals with Arrows Green arrows are used to direct traffic in one particular direction. You can expect not only green, but also yellow and red arrows to be more widely used.</p> <p>Meanings of Various Lights On control signal "C," the steady green arrow means you may: A. Go straight ahead only after stopping. B. Go straight ahead only, without stopping. (B is correct) C. Turn right after stopping. On control signal "A," when the green arrow is on with the red light, you may: A. Turn right without stopping. (A is correct) B. Turn right after stopping.</p> <p>A steady yellow X in lane signal "f" means: A. You should continue to drive in this lane. B. Prepare to change lanes. (B is correct)</p>

Teaching Point	Rationale
	<p>A flashing yellow X in lane signal 'T' means:</p> <ul style="list-style-type: none"> A. Left turn only are permitted from this lane. (A is correct) B. The lane will be changing to a prohibitive lane. <p>The red X in lane signal "J" means:</p> <ul style="list-style-type: none"> A. Do not drive in this lane. (A is correct) B. Stop and yield <p>When coming to a flashing red light such as "G" you should:</p> <ul style="list-style-type: none"> A. Slow down, then go with caution B. Stop and stay until the light changes. C. Stop, yield, and go when clear. (C is correct) <p>What should you do when approaching a flashing yellow light?</p>
Important Teaching Points	<ul style="list-style-type: none"> • The "stale green" concept should be presented at this time. Emphasize that when the driver first identifies the traffic light and it is green, then the driver should approach the traffic light anticipating that it will change. • If a student has a difficult time with this when-driving, have the driver use the following process: • As the driver approaches the "green" light, the driver should mentally say: "I can stop now if the light changes, I can stop now if the light changes, I can;"and when the driver gets to the location where the driver can say: " I can clear now if the light changes"; • what the driver is consciously doing is approaching the traffic light at a controlled speed. • This process works and needs to be introduced and demonstrated by the teacher.
Show C-F Master.	<p>Pavement Markings</p> <p>General meaning- Pavement markings are used both to warn and regulate traffic. They usually supplement signs, but they may be used without signs.</p> <p>White arrows in a lane usually indicate the only direction traffic may move. Words or symbols are read from near too far.</p> <p>Illustrations of Various Situations:</p> <p>Illustration "A" shows a four-lane undivided highway with double yellow center lines. Crossing these center lines is permitted only for a left turn into an alley, driveway or business.</p> <p>"B" shows markings for a multi-lane two-way roadway with a left turn lane. The center lane is reserved for left turns only, from either direction. Emphasize the approximate distance that a driver should enter this lane when making a left turn, e.g., speeds under 35 mph, approximate 100 feet and speeds in excess of 35 mph would be 300 feet. You should also demonstrate how the lane can be used as a safety zone when making a left turn from a business, and you have a safe gap from the left but not from the right. Emphasize that this action should</p>

Teaching Point	Rationale
	<p>be slow and non-threatening to the traffic coming from the right and to set-up in the turning lane ready to make a lane change to the right when there is a safe gap.</p> <p>"C" illustrates a center lane in which the direction is reversible during certain times of the day.</p> <p>Drawings "D" and "E" show divided highways. The median in "E" has space for emergency use. "D" has a raised median that is not usable.</p> <p>"F" illustrates a no passing zone on a two-lane, two-way highway.</p> <p>Specific Meanings Pavement markings that are used to separate traffic moving in opposite directions are: A. White lines B. Yellow lines (B is correct) C. Black lines</p> <p>Pavement markings that are used to separate traffic moving in the same direction are: A. White lines (A is correct) B. Yellow lines C. Black lines</p> <p>What is the difference between a broken white line and a solid white line? Where is each type found?</p>
<p>Important Teaching Point</p>	<ul style="list-style-type: none"> • Before using the flash-slide training activity in regards to Identifying and Evaluating Traffic Controls, you should consider using the AAA video "Are You Reading Me?" or one similar that emphasizes the various traffic controls (signs, signals, markings).
<p>Hand out the Perception of HTS Events Answer Sheet</p>	<p>Flash-Slide Activity</p> <p>Here are some answer sheets for a flash-slide training activity. Print your name at the top of the sheet and then listen carefully to a brief description of the activity.</p> <p>Slides of traffic situations will be flashed on the screen for a period of about five seconds. You are to assume you are driving and that the picture on the screen is what you would see through your windshield.</p>
<p>Show the Answer Sheet with a Transparency made From Master</p>	<p>This practice should help you identify traffic and highway conditions more quickly when driving. It should also test your short recall ability, which can be very important in some traffic situations.</p>

Slides one and two are Demonstration Slides, and each one will be left on the screen for identification and discussion. Please remember that you are only searching for Traffic Controls.

Look at the traffic scene as you would if you were the driver of the vehicle from which the pictures were taken. Remember to use the searching habits that were introduced in Session One, e.g., search from side to side in relation to your projected path of travel and work out as far as you can see.

C-1: Before putting C-1 on the screen, tell the students "You are searching for Traffic Controls."

After the slide is on the screen, select individual students to identify a traffic control, its meaning and/or required action, e.g.

- You are on a four lane, two-way roadway and in lane two.
- Warning sign identifies a Blind Person Area.
- Warning sign indicating an approach to a traffic light. What types of action should this trigger on your part? Visual search ahead, rear and to side; speed reduction.
- Warning sign with 45 mph.
- Warning sign indicating intersection.
- Sight distance should be as far as environment allows.

Once all of the above is identified and discussed, ask the following questions:

- A. You are on a four lane, two-way road way. True
- B. You are approaching a traffic light. True
- C. You are approaching a four-way intersection. True

C-2: Before putting C-2 on the screen, remind the students "You are searching for Traffic Controls."

After the slide is on the screen select individual students to identify a traffic control, its meaning and/or required action, e.g.

- You are on a two lane, two-way roadway.
- The posted speed is 55 mph.
- You are approaching a divided highway.
- You are approaching a three-way intersection. This intersection sign is important because it can dictate when there might be less risk if desiring to pass the truck. This is also a good traffic scene to emphasize a high projected path of travel.

Once all of the controls are identified and discussed, ask the following questions:

- A. You are on a two-lane, two-way roadway. True
- B. The posted speed is 45 mph. False
- C. You are approaching a divided highway. True

You are now ready to do five practice test slides. Remember that before you put the slide on the screen, remind them that they are searching for traffic controls and if they need to identify a route number, remind them ahead of time. You will put the slide on the screen for a long five seconds, go to the blank slide and ask three questions. The students should respond with a True or False. Once the questions are asked, the practice test slide should be put back on the screen to score and discuss.

C-3: Search for Traffic Controls and Route 74 ... Ready?

- A. You are on Route 74. False
- B. The railroad crossing is controlled with lights. True
- C. Route 74 is a federal highway. False

Put C-3 back on the screen for scoring and discussion. If you have it wrong, put an "X" over the response.

- A. False, you are approaching Route 74 because of the junction sign.
- B. True, this is a railroad crossing that has both a regulatory sign and the lights. Please also note where the stop line is in relation to the traffic light and the railroad crossing.
- C. False, Route 74 is a state highway and so noted with the symbol of the keystone.
 - Approaching a "stale" green light with a No Turn on Red sign.

C-4: Search for Traffic Controls ... Ready?

- A. The right lane will end. True
- B. You are approaching a construction zone. True
- C. The construction speed limit sign is regulatory. True

Put C-4 back on the screen for scoring and discussion.

- A. True, the right lane is ending because of the construction zone
- B. True, the signs, signals, barrels all show construction.
- C. True, the speed limit sign is black and white and a part of the construction sign.
 - The divided highway ends and you are going from four lanes to two lanes and two-way traffic.

C-5: Search for Traffic Controls... Ready?

- A. You are on a street with reversible lanes. True
- B. You may change lanes to the left. False
- C. You may change lanes to the right. True

Put C-5 back on the screen for scoring and discussion

- A. True, note the different type of lane markings and the overhead signals. Evidently this is a period time between the morning and afternoon rush hour.
- B. False, overhead signals show four lanes, two-way traffic.
- C. True, overhead signals show lanes available for driving.

C-6: Search for Traffic Controls and Route 94... Ready?

- A. The lane you are in will divide. True
- B. To proceed to Route 94, you must change lanes. False
- C. Route 94 is an Interstate Highway. True

Put C-6 back on the screen for scoring and discussion

- A. True, you are in lane two of a three lane roadway and lane two splits. Note the warning sign in the "gore" area.
- B. False, lane two splits and you will continue straight staying in lane two.
- C. True, the interstate sign indicates the type of highway and evidently Interstate 94 temporarily uses a section of the North Expressway.

C-7: Search for Traffic Controls and Interstate 70 West... Ready?

- A. To go west on Interstate 70, you need to make one lane change to the left. False
- B. The two right lanes are exit only lanes. True
- C. You are on a four-lane one-way roadway. True

Put C-7 back on the screen for scoring and discussion

- A. False, you are in lane four and lanes one and two are needed for Interstate 70 West.
- B. True, the overhead signs indicate lanes three and four exit only.
- C. True, the lane lines are all white starting from your right and going to the left toward the median barrier.
 - Take note that Interstate 55 would run in a north south direction.

You are now ready to do the three test slides. You will put the test slide on the screen for a long five seconds, go to the blank slide and ask the three questions. Once the questions are asked then go to the next test slide and then the last. It is recommended that the instructor scores these three test slides and at the next class, hand the test sheets back to the students for review purposes with the respective slides on the screen.

C-8: Search for Traffic Controls... Ready?

- A. You are on a two lane, two-way street. True
- B. At the next intersection, you may proceed straight. False
- C. You are approaching a "stale" green light. True

Discussion when reviewed:

- Note double yellow center line.
- Note traffic light that is green.
- Note the Do Not Enter regulatory signs and thus the need to turn right or left.
- Right turn on red would be permitted.

C-9: Search for Traffic Controls... Ready?

- | | |
|---|-------|
| A. You are on a one-way street. | True |
| B. To turn left, you must change lanes to the left. | True |
| C. After the intersection, your street continues one-way. | False |

Discussion when reviewed:

- Note the lane lines, markings, and signs.
- Right turns on red are permitted.
- Note the number of traffic lights over respective lanes.

C-10: Search for Traffic Controls... Ready?

- | | |
|---|-------|
| A. You should prepare to make a left lane change. | True |
| B. The posted speed is 45 mph. | False |
| C. Vehicles turning left have a red light. | True |

Discussion when reviewed:

- The right lane ends ahead, and this is after the traffic light.
- The posted speed is 35 mph.
- You are approaching a "stale" green light.
- There are two left turning lanes controlled by their respective traffic lights.

Session Summary

- Traffic controls are improved periodically, so we should keep up-to-date.
- There are four main classes of signs -regulatory, warning, guide and construction. Each group of signs has distinctive colors and shapes.
- You can identify traffic signs quickly by knowing the shapes, colors and symbols.
- In the future, traffic control signals will have more arrows.
- It is important to know and look for clues, which indicate when signal lights will flash on and off.
- White pavement markings are used to separate traffic moving in the same direction.
- Yellow pavement markings are used to separate traffic moving in opposite directions and they are always to your left in this country and most others. Where would this be the exception?
- Right-of-Way Laws:
 - Traffic controls are directly related to Right-of-Way Laws. On page 40, Right-of-Way Laws are discussed and case studies are provided for problem solving and discussion.

Right of Way Laws

Right-of-Way Laws are for drivers and pedestrians who wish to use the same roadway space at the same time.

- Their purpose is to prevent conflicts by having one user yielding to the other.
- There are rules for deciding who should go first.
- They have nothing to do with our basic rights or freedoms.

Giving the right-of-way is the same as yielding space.

- Ask who should first yield space in the roadway?
- You have not yielded if other driver must wait or go slower.

Having the right to go first does not always give one the right to take it.

- Common Law requires us to take due care to avoid crashes.
- Whoever has "last clear chance" should prevent the crash.
- To have the right to go first, you must first be given it.

When at least two drivers approach a right-of-way situation, both should be prepared to yield.

- In case of error, no one will get hurt.
- Anyone can become confused in such situations.
- Being lawfully right does not spare one the cost, suffering or inconvenience from a crash due to error.

The following transparency masters of situations (C-G through C-N) are provided for a discussion of the laws. Some may prefer to use just the diagrams for a test.

Objectives

- Identify the regulatory signs and their respective meanings based on color, shape and symbol
- Identify warning signs and their respective meanings based on color, shape and symbol
- Identify guide signs and their respective meanings based on color, shape, symbol and numbering
- Identify construction signs and their respective meanings based on color, shape and symbol
- Identify the various traffic light signals and their respective meanings
- Identify the various lane markings and their respective meanings

Regulatory Signs

Read from Bottom Up

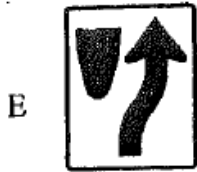
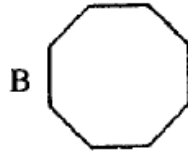
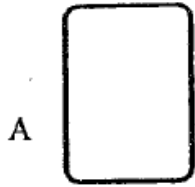

Warning Signs

Colors

Shapes

Symbols

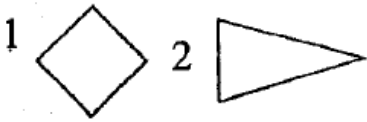

Crossings

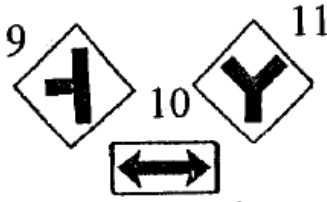

Intersections

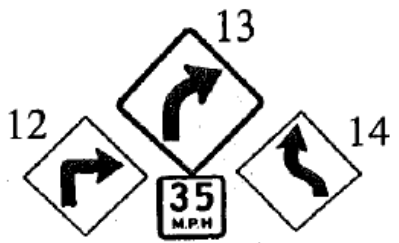

Curves

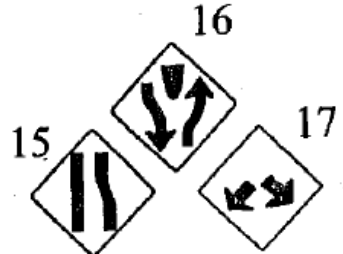

Changes in Width



Traffic

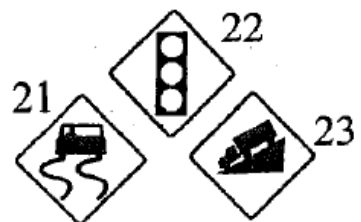

Road Conditions

Read from Bottom Up

Guide Signs

Colors – Shapes – Symbols



Destination and Mileage



Recreation Areas

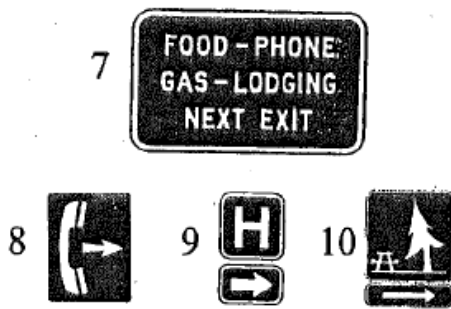

Roadside Services

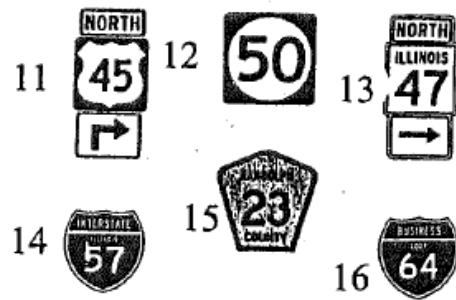

Route Markers

Read from Bottom Up

Traffic Control Signals



A



B

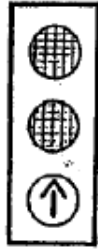

C



D



E

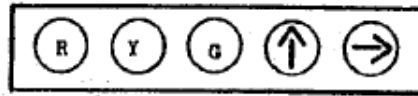

F



G



H



I

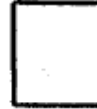

J



Pavement Markings

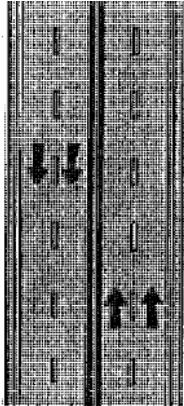

A

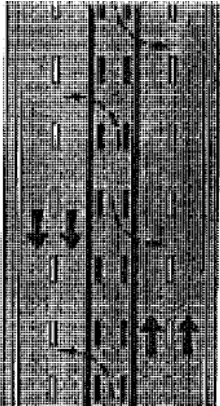

B

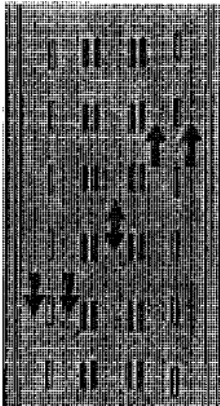

C

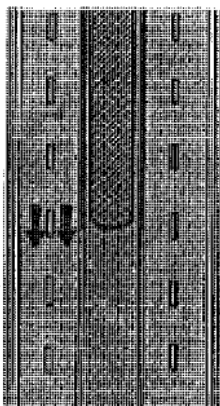

D

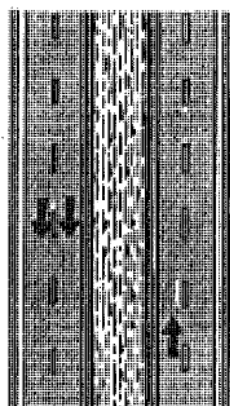

E

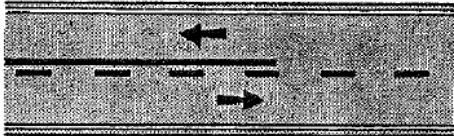

F

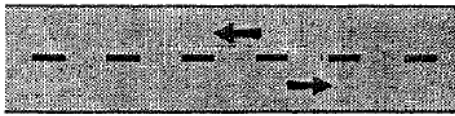

G

Right of Way Laws: Entering Unmarked or Open Intersections

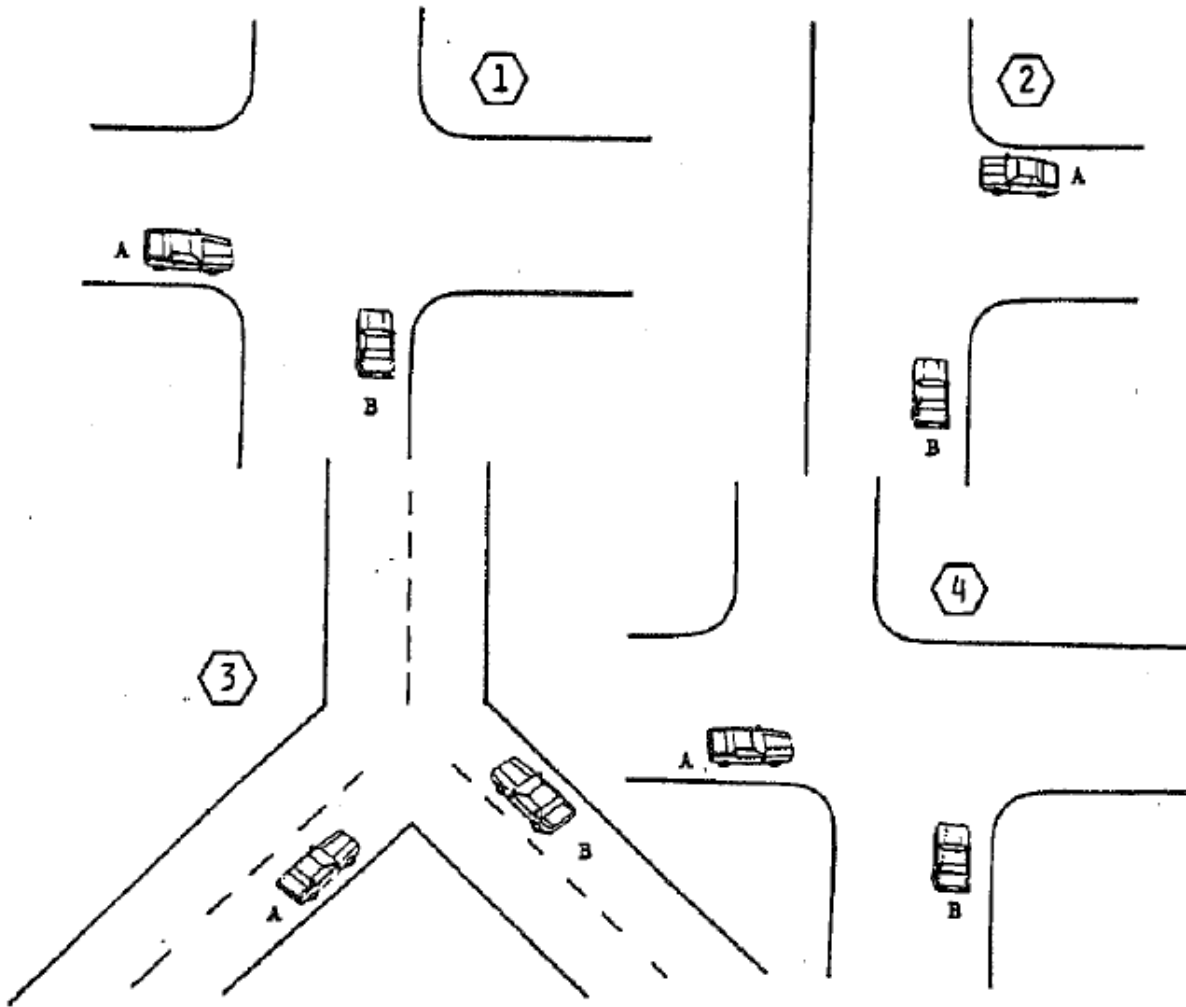

When two vehicles approach or enter an intersection from different roadways at about the same time, the driver of the vehicle on the left must yield the right-of-way to the vehicle on the right.

Right-of-Way Laws: Entering Roadway from Driveways, Alleys and Parked Positions

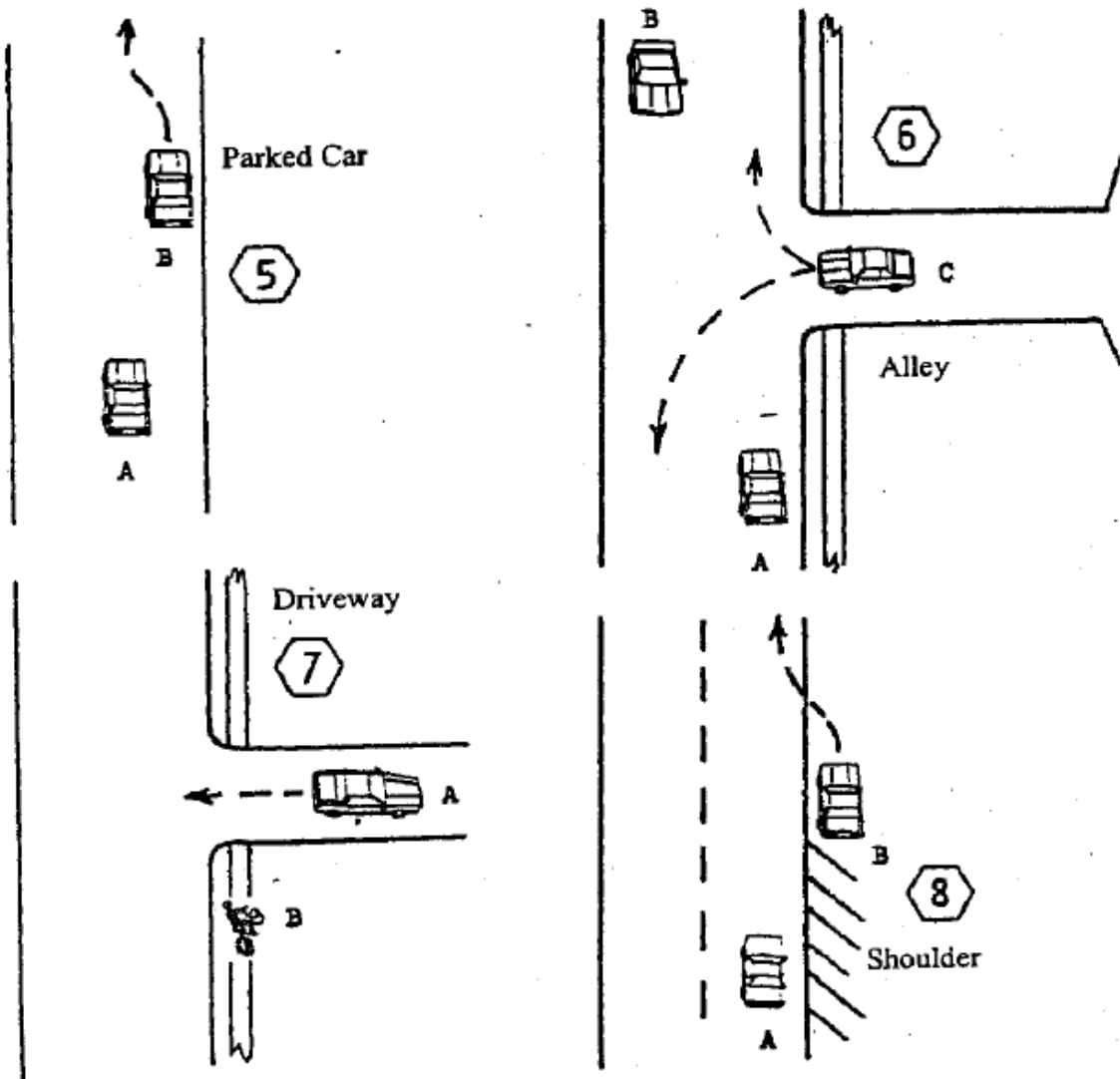

The driver entering a roadway from a parked position, standing position, parking lot, shopping area, alley, and private drive shall yield to cars approaching on the roadway and to pedestrians on the sidewalk.

Right-of-Way Laws: Lane Ends or Is Obstructed

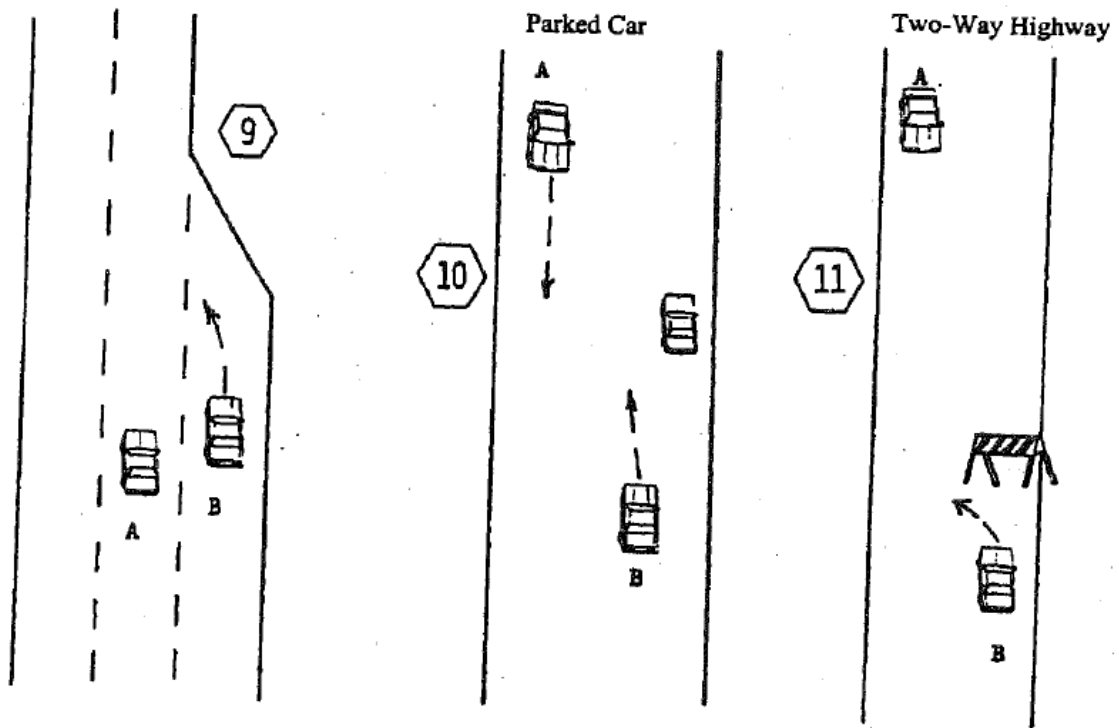

When a lane ends or there is a object in the lane, the driver of a vehicle using this lane shall yields the right-of-way to oncoming vehicles or following vehicles in the adjacent lane.

Right-of-Way Laws: Vehicles Turning Left Against Traffic

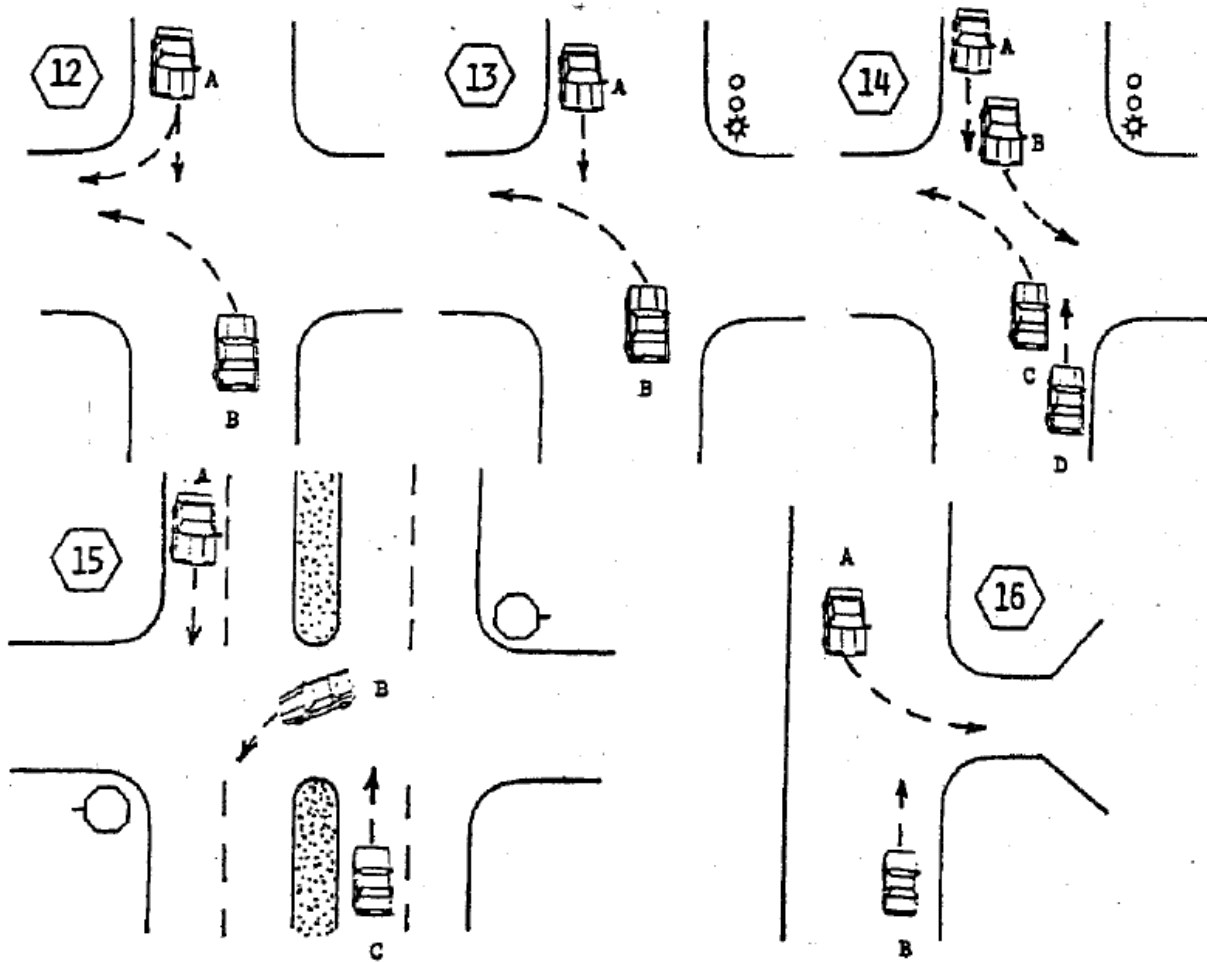

A driver turning left within an intersection, into a driveway, into an alley, and into an off-street area shall yield the right-of-way to vehicles approaching from the opposite direction.

Right-of-Way Laws: Entering Intersections Controlled by Signs and Flashing Reds

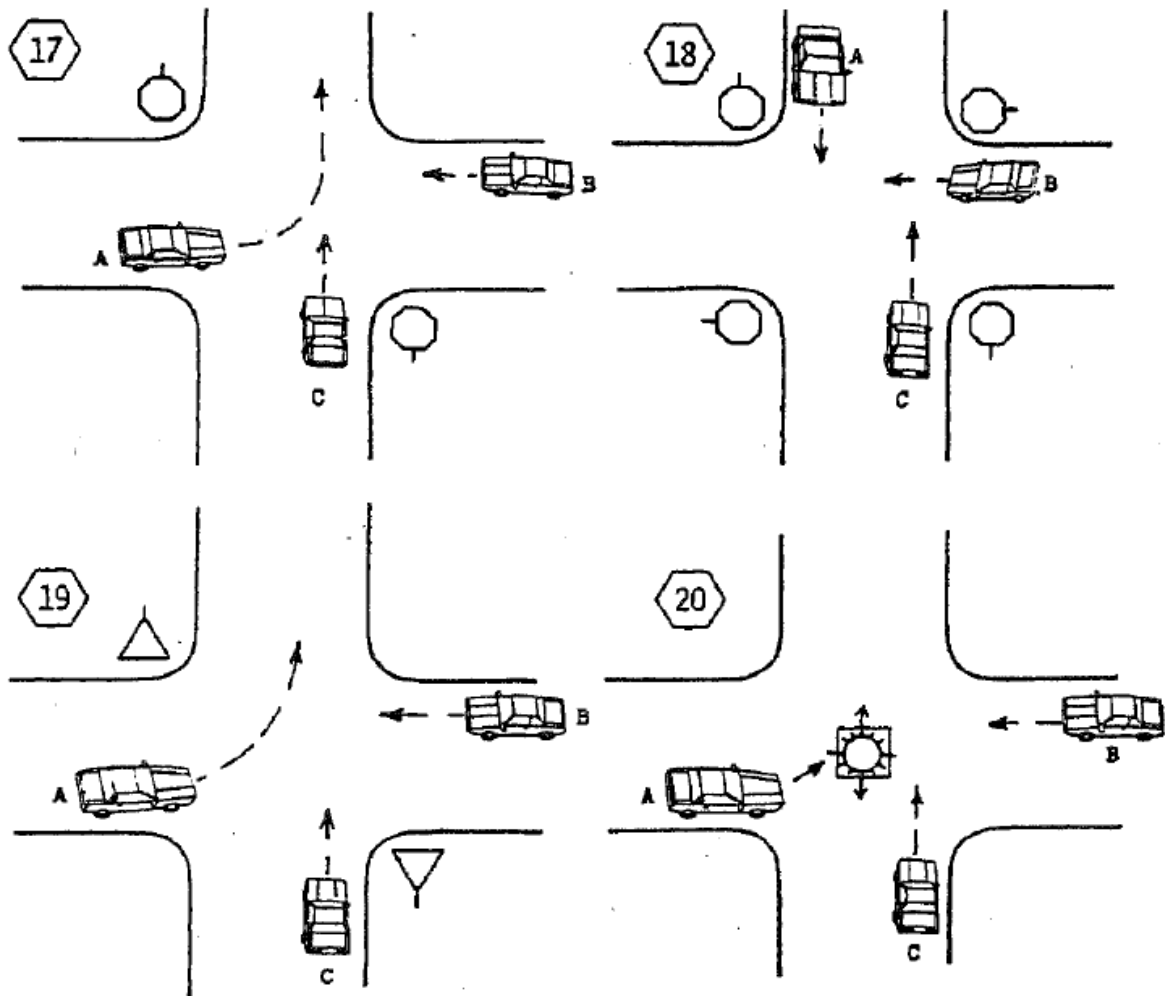

A driver entering an intersection controlled by a stop sign, yield sign, or red flashing signal light shall yield the right-of-way to any auto in the intersection or approaching from another direction. Coming to a complete stop does not relieve the driver of the duty to yield before entering.

Right-of-Way Laws: Intersections Controlled by Traffic Signal Lights

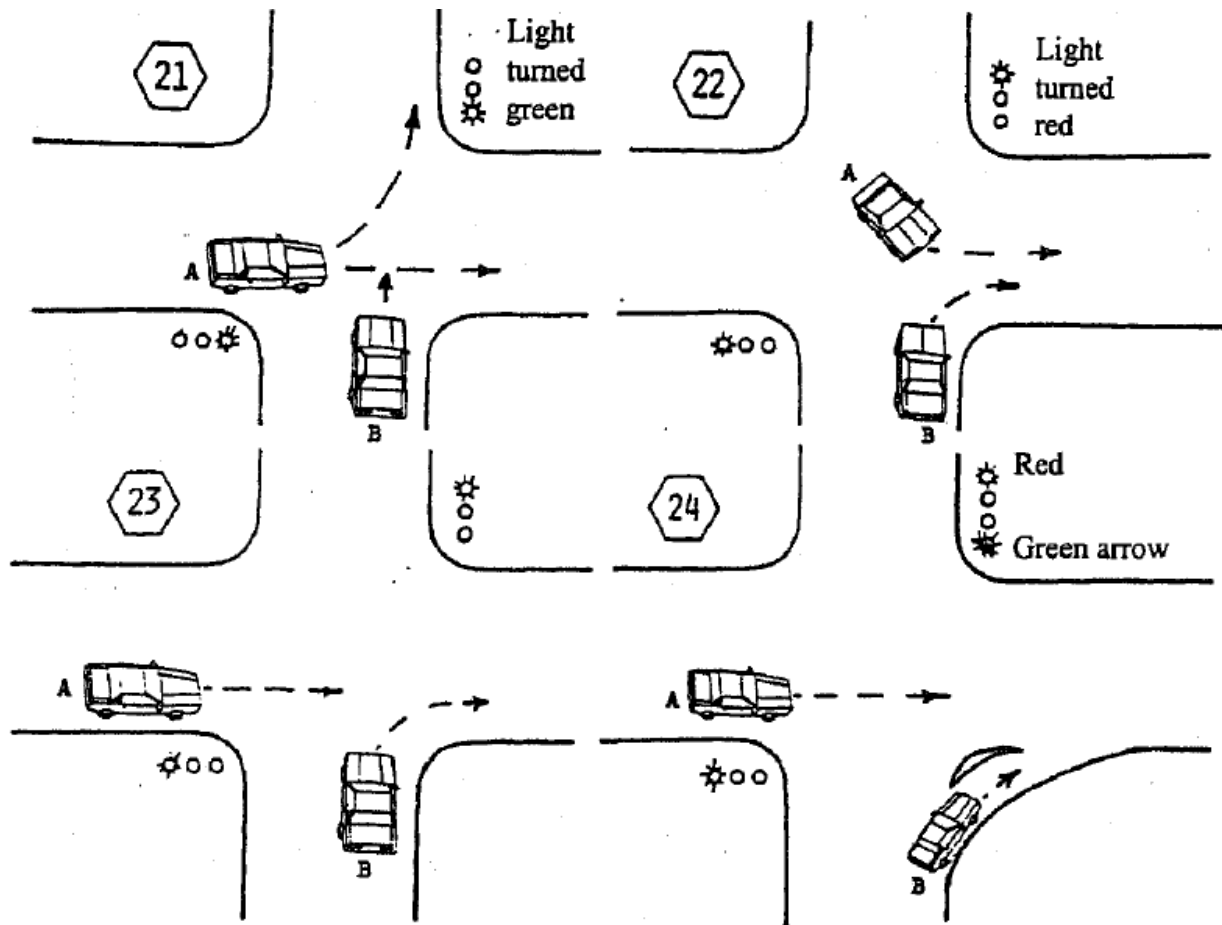

Drivers facing the steady green signal light, with or without arrows, shall yield the right-of-way to other autos and pedestrians legally within the intersection at the time such signal is lighted. Drivers facing the steady red signal light and turning right, when allowed, shall yield the right-of-way to other vehicles and pedestrians lawfully within the intersection.

Right-of-Way Laws: Pedestrians Crossing Situations

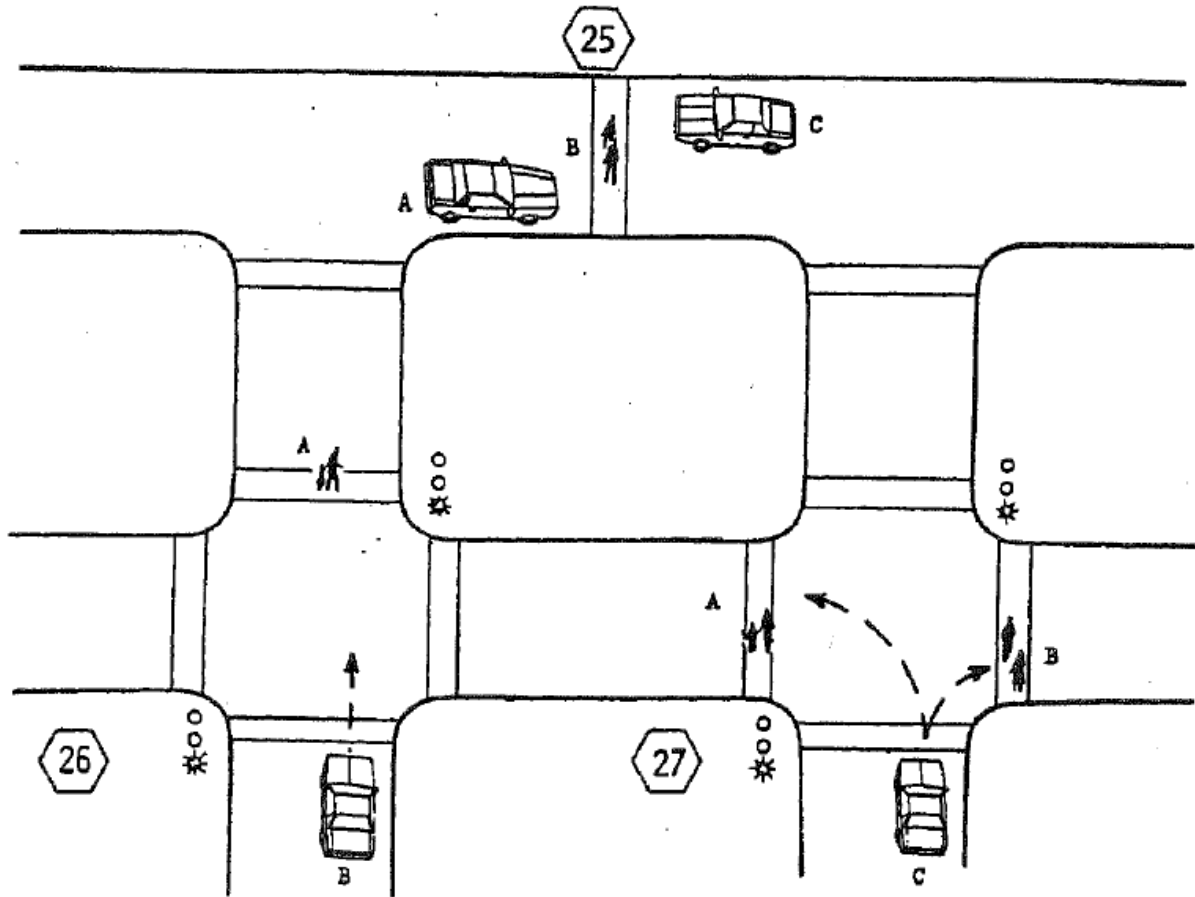

The driver of a vehicle must yield to a pedestrian crossing the road at a crosswalk—marked or unmarked. Pedestrians crossing the roadway other than at a crosswalk must yield to vehicles on the roadway. Blind persons with a white cane or a guide dog are an exception to the rule.

Right-of-Way Laws: Entering and Passing Through Traffic Circles

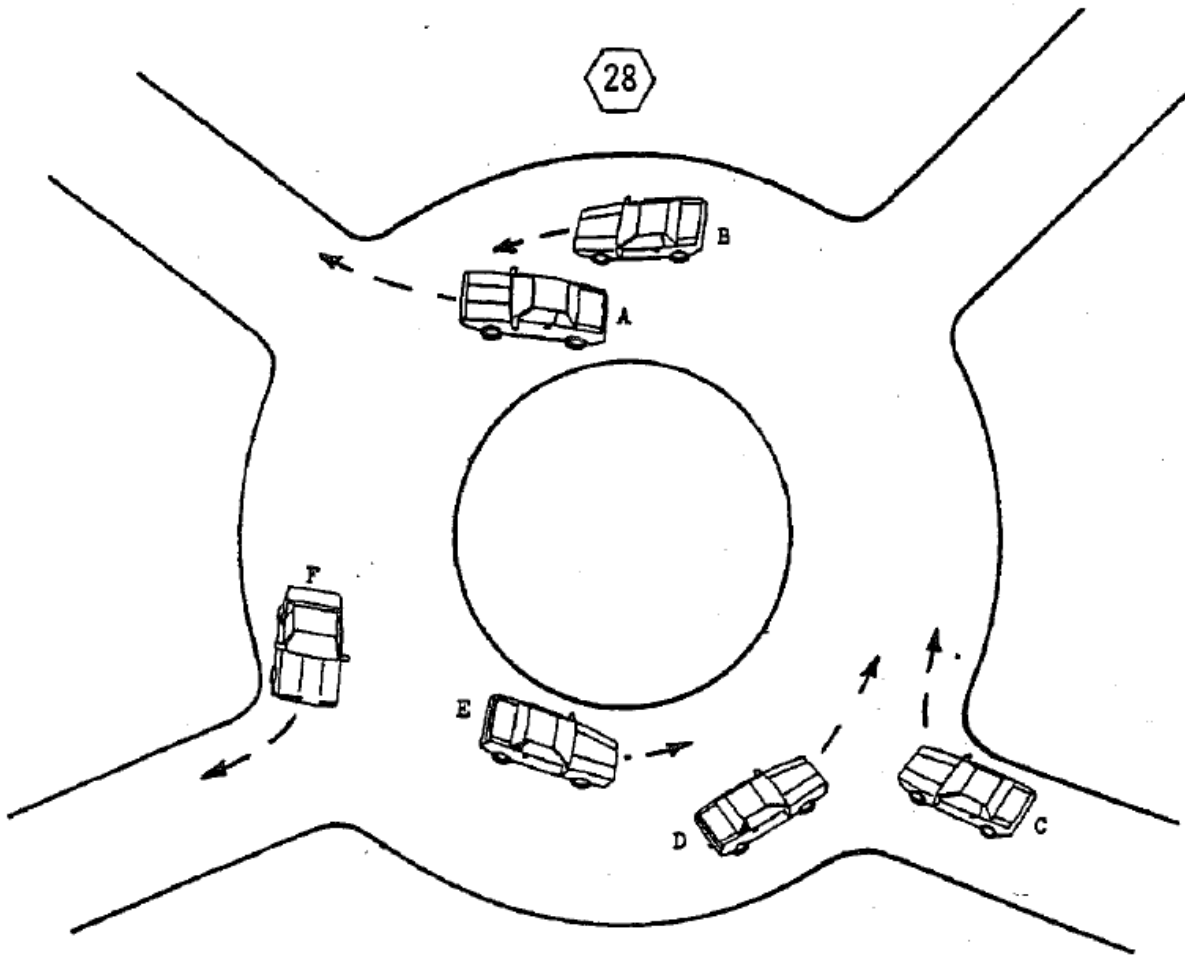

The driver of a car entering the circle shall yield to vehicles already in the circle. The driver of a car within the circle shall yield to another vehicle within the circle and intending to leave the circle.

Session Three: Identifying Highway Conditions

Time:

Minimum of one class period and maximum of two class periods.

Purpose:

There are three highway conditions that constantly need to be monitored as they relate to a driver's projected path of travel. These three conditions will directly affect the driver's speed and position selection and, in some instances, selective communication." Two of these conditions, space and visibility, can either be affected by highway conditions (static), or other users (dynamic). The third condition is traction, and this is affected by either roadway conditions (static), or surface materials (static). Identifying changes in the above conditions, as far out as possible in the projected path of travel, can mean the difference between a smooth and gentle trip, versus a sudden panic situation. Identifying highway conditions, as soon as possible, puts a driver more in control. The driver education text should serve as a resource for this session, and the most appropriate parts would include:

1. Selective Driving Environments
2. Sharing the Roadway with Other Users

Materials/Equipment:

- Perceptual Driving Program, Session Three
- Driver Education Text Pennsylvania Driver's Manual Selective Worksheets
- Slide Projector
- Screen
- Overhead Projector or Power Point
- Computer/Software
- CD Rom -Module III, Perception and Driving Strategies for Different Environments
- Computer with CD capability and LCD Projector

Session Objectives:

1. Students can define an area of less space;
2. Students can identify static highway conditions that cause areas of less space;
3. Students can identify dynamic traffic conditions that cause areas of less space;
4. Students can define less sight distance and view to the sides;
5. Students can identify static highway conditions that affect visibility;
6. Students can identify dynamic traffic conditions that affect visibility;
7. Students can identify clues to hidden side roads;
8. Students can define less traction;
9. Students can identify roadway conditions that affect traction; and
10. Students can identify surface materials that affect traction.

Session Outline:

1. Introduction
2. Changes in Space to Sides
 - a. Definition of Less Space to Sides
 - b. Changes Due to Highway Conditions
 - c. Changes Due to Traffic Conditions
3. Changes in Visibility
 - a. Definition of Less Sight Ahead and to Sides
 - b. Changes Due to Highway Conditions
 - c. Changes Due to Traffic Conditions
 - d. Clues to Hidden Side Roads
4. Changes in Traction
 - a. Definition of Less Traction
 - b. Changes Due to Roadway Conditions
 - c. Changes Due to Surface Materials
5. Flash-Slide Activity for Application
 - a. Demonstration Slides
 - b. Practice Slides
 - c. Test Slides
6. Session Summary

Guidelines for Conducting Session-Three:

Teaching Point	Rationale
Introduce session. These concepts are used in rest of course.	<p>Introduction</p> <p>In this session, you will practice the identification of the second major group of HTS events- Highway Conditions. There are three main conditions of the highway that need to be identified at all times. These are space, visibility and traction. However, it is the changes in these conditions that can easily result in problems.</p>
Show H-A Master. Show each objective as it is presented.	<p>In session three, you will be expected to demonstrate the following objectives: Show and discuss each objective from H-A Master.</p> <p>To accomplish this, you will use visuals to help define and illustrate what to look for in an orderly way. Then you will practice, using the flash-slide method.</p>

Teaching Point	Rationale
Emphasize definition for highway.	<p>We will define highway as including the roadway, medians, shoulders and other areas between the boundaries.</p> <p>Changes in Space to Sides</p> <p>A driver needs adequate space for crossing, turning, merging or performing any other maneuver. Such space also gives the driver better visibility and more time to react to the changing conditions.</p> <p>The amount of space required varies with the speed being traveled and the maneuver to be made.</p>
Show H-B Master.	Definition of Less Space to Sides
Make sure definitions are clearly understood.	<p>We shall define an area of less space to the sides as a condition in which one of the following is true:</p> <ol style="list-style-type: none"> 1. The driver does not have at least one car width of safe, drivable space next to the intended path. 2. The roadway itself gets narrower ahead. 3. In other words, ahead of the driver's current path of travel, there is a change in the amount of available space. 4. Even though the focus here is on reduced space, areas of increased space to the sides are changes that also need to be identified and responded to.
Show H-C Master.	Changes Due to Highway Conditions
Ask class for other "static" situations that affect space.	<p>Many changes in space to the sides are due to highway conditions or features. Here are examples:</p> <ul style="list-style-type: none"> • Pavement width changes from 24 feet to 20 feet; • There may be one or two whole lanes less; • Corner curbing may be less rounded; • Shoulders may become narrower; • Guardrails, embankments, snowbanks or rock slides may prevent you from having an escape path; • There may be fencing, posts, trees, barricades or other objects that cut down on the space available; and/or • Ask the class for other examples of "static" conditions.
Show H-D Master.	Changes Due to Other Traffic

Teaching Point	Rationale
Ask class for other "dynamic" situations that affect space.	<p>Other traffic can limit side space temporarily. Here are examples:</p> <ul style="list-style-type: none"> • Oncoming line of cars, with parked cars to the sides; • Double-parked cars or delivery trucks, stalled vehicles or vehicles waiting to turn; • Large vehicles coming or going around a corner; and/or • Bike riders or pedestrians in combination with less roadway space at a certain location. <p>Changes in Visibility How well and how fast you can guide your car along the road will depend a great deal on adequate visibility. You must be able to see ahead and to the sides if you are to avoid collisions.</p>
Show H-E Master.	<p>Definitions of Less Sight Ahead and Less View to Sides An area of less sight distance and an area of less view to the sides shall be defined as a highway area in which the sight distance ahead or to the sides is less than that required for safe travel at the speed being driven.</p> <ul style="list-style-type: none"> • In other words, without an adjustment in speed, you wouldn't be able to stop in time if a car came into your path of travel. • At speeds in excess of 35 mph, if you can't see a minimum of four seconds to the front or to the sides, you are driving into an area of less visibility. • At speeds less than 35 mph, the less sight distance or view to the sides is two seconds. • The line of sight is the imaginary straight line that connects the eyes with the point focused on. It is the line along which you are looking at any given time. • The view to the sides, or field of view, is the entire area of the highway and its surroundings that can be seen at a particular moment.
Show-H-F Master.	Changes Due to Highway Conditions
Ask class to give other examples of "static" conditions that affect visibility.	<p>Most changes in visibility are the result of highway conditions. Here are some examples:</p> <ul style="list-style-type: none"> • Embankments, curves, shrubs, buildings and signs; • Hills, curves and hillcrests, which can easily hide a disabled car or slow-moving vehicle; • The time of year- such as planting and harvesting seasons in rural areas; • The time of day- such as rush hours or times when school buses are on the road; and • Sudden changes in weather - such as rain, snow or fog.
Show H-G Master.	Changes Due to Other Traffic
Ask class to give other examples of "dynamic" conditions that affect visibility.	Other traffic can create both visibility problems and space problems. Large trucks and buses can reduce the view ahead or to the sides.

Teaching Point	Rationale
Show H-H Master.	Clues to Hidden Side Roads
Ask class to give other clues that might indicate hidden side roads.	In rural areas, many side roads may be hidden from view. Look for clues such as these: mailboxes, telephone wires, cloud of dust from gravel roads, animals, pedestrians or slow-moving vehicles. Changes in Traction Without traction, vehicle movement and control would not be possible. A driver must always be alert for areas of less traction and be able to evaluate its effect on vehicle control Less traction usually increases the possibility of skidding.
Show H-I Master.	Definition of Less Traction An area of less traction is a condition of the roadway ahead which will cause the friction or grip between the tires and the driving surface to be reduced. It represents a change of the surface on which you are driving.
Show H-J Master.	Changes Due to Roadway Conditions
Ask class to give other examples of roadway conditions that affect traction.	<ul style="list-style-type: none"> • Slope of the Roadway Surface -Is it flat, banked or crowned? This is especially important on curves. • Condition of Shoulders - Is it level with the pavement? Is it soft or rough? • Breaks in Surface - Are there railroad tracks, sewer covers or drain grills? Are there large cracks or pot holes? These are especially important for two-wheelers.
Show H-K Master.	Changes Due to Surface Materials
Ask class to give other examples of surface materials affecting traction.	Be alert for hazardous weather conditions in combination with the presence of mud, leaves, tar, ice, snow, or spillage from trucks Wind gusts from the sides, the beginning of rain, or quick changes in temperature need to be evaluated
Pass out answer sheets.	Flash-Slide Activity Are there any questions regarding how to define less space, less traction, less sight distance or less view to the sides?
Remember to read questions slowly.	Let's begin our flash-slide activity. Here are your answer sheets. Remember, our main focus of attention will be on the change in highway conditions. Use the second column of your answer sheet. Slides one and two are Demonstration Slides and will be left on the screen for identification and discussion. Please remember to continue to use the searching habits that you used in Session Two, but only search for negative highway conditions.

H-1: Search for Highway Conditions...Ready?

After the slide is on the screen, select individual students to identify any highway conditions that can affect the driver's projected path of travel, e.g.

- Space is affected by a static highway condition (the railroad overpass) and a dynamic traffic situation (oncoming traffic);
- Traction is affected by a surface material (water standing on surface); and
- Visibility appears to be satisfactory.

Once these conditions are identified, ask the following questions:

- A. You are approaching an area of less space True
- B. You are approaching an area of less traction True
- C. You have less visibility False

H-2: Search for Highway Conditions... Ready?

After the slide is on the screen, select individual students to identify any negative highway conditions, e.g.

- Space is affected by lack of shoulders (static) and approaching van (dynamic);
- View to the sides is reduced with the hidden driveways to the right;
- Sight distance will be reduced as you approach the crest of the hill (static); and
- Traction does not appear to be a problem.

- A. You are approaching an area of less space. True
- B. There are hidden driveways to the right. True
- C. Your traction is reduced. False

You are now ready to do the five practice slides and use the procedure that you did in Session Two.

H-3: Search for Highway Conditions... Ready?

- A. You are in an area of less space. True
- B. There are hidden side roads to the left and right. True
- C. You are approaching an area of less sight distance. True

Put H-3 back on the screen for scoring and discussion

- A. True, you are on a narrow bridge and you are approaching a car entering the roadway from the left.
- B. True, vehicles to the left and right provide a clue.
- C. True, static roadway conditions of a curve to the left.

H-4: Search for Highway Conditions...Ready?

- A. You are approaching an area of less space. True
- B. You have good sight distance. False
- C. You have less traction. False

Put H-4 back on the screen for scoring and discussion

- A. True, construction workers (dynamic) are affecting space and snow (static) pushed out toward the road surface.
- B. False, the truck (dynamic) is affecting our sight distance.
- C. False, your traction on the road surface is satisfactory.

H-5: Search for Highway Conditions... Ready?

- A. Your space is reduced. False
- B. You are approaching an area of less sight distance. True
- C. You are approaching an area of less traction. True

Put H-5 back on the screen for scoring and discussion

- A. False, your space appears to be constant, there is no reduction
- B. True, sight distance is reduced because of the sharp curve to the left and shrubs and embankment on the left (static).
- C. True, surface material can be identified in the curve and this happens many times on rural roads where there are entering side roads and sharp curves.

H-6: Search for Highway Conditions...Ready?

- A. Your space is satisfactory. True
- B. You have good visibility. True
- C. You have good traction. True

Put H-6 back on the screen for scoring and discussion.

- A. True, this is a good example of satisfactory space, multiple lanes and width of shoulders.
- B. True, you have both good sight distance and view to the sides.
- C. True, the road surface provides satisfactory traction.

H-7: Search for Highway Conditions: Ready?

- A. You are approaching an area of less space. True
- B. You are in an area of less traction. True
- C. You have poor sight distance. True

Put H-7 back on the screen for scoring and discussion.

- A. True, the oncoming tractor trailer is crowding the center line with the front wheels and the rear tractor wheels and the trailer wheels will come even closer. Note how the rear tires of the tractor are on the center line and the trailer tires are over the center line.
- B. True, the surface of the road is rough, there is gravel to the left from the intersection and this is forcing the oncoming truck to crowd you, and the shoulders are in poor condition.
- C. True, the right curve and embankment affect visibility.

You are now ready to do the three test slides, and you should follow the same procedure as you did in Session Two.

H-8: Search for Highway Conditions: Ready?

- A. You are approaching an area of less space. True
- B. You have good sight distance. False
- C. You are approaching an area of less view to the side. True

Discussion when reviewed:

- Space is affected by parked cars on right, retaining wall on left, and oncoming vehicles.
- Sight distance is reduced with the crest of hill.
- View to sides is reduced because of parked cars and buildings, and you are approaching an intersection on right.

H-9: Search for Highway Conditions: Ready?

- A. You are approaching an area of less space. True
- B. You are approaching an area of less sight distance. True
- C. The shoulder ahead is level with the roadway. False

Discussion when reviewed:

- Space is affected by the bridge (static) and the road grader (dynamic).
- Sight distance is affected by the left curve (static).
- Shoulder beyond the bridge is in poor condition. It appears that the road grader is working on the shoulders.

H-10: Search for Highway Conditions...Ready?

- A. You are driving in an area of less space. False
- B. You have good sight distance. True
- C. There are hidden driveways to the right. True

Discussion when reviewed:

- Space is more than adequate with roadway and shoulders.
- Sight distance is excellent, but the driver will eventually encounter a short sight distance.
- There are driveways to the right and visible clues to help identify them.
- Traction is satisfactory.

Session Summary

- Space, visibility and traction are the primary highway conditions that need to be perceived at all times. For each of these conditions, there are a number of clues to look for.
- Less space to the sides is a change in the available space ahead that is compared to that in the area being traveled on.
- Less sight distance ahead and less view to the sides are conditions in which the stopping distances are unsafe without an adjustment in speed.
- Less traction is a condition ahead which will lessen the friction between the tires and the road surface.
- When any of these primary conditions are not identified well ahead and responded to, there is a good chance for loss of control or serious conflicts with other users.

Objectives

1. Define an area of less space
2. Identify static highway conditions that affect space
3. Identify dynamic traffic conditions that affect space
4. Define less sight distance and view to the sides
5. Identify static highway conditions that affect visibility
6. Identify dynamic traffic conditions that affect visibility
7. Identify clues to hidden side roads
8. Define an area of less traction
9. Identify roadway conditions that affect traction
10. Identify surface materials that affect traction

Less Space to Side

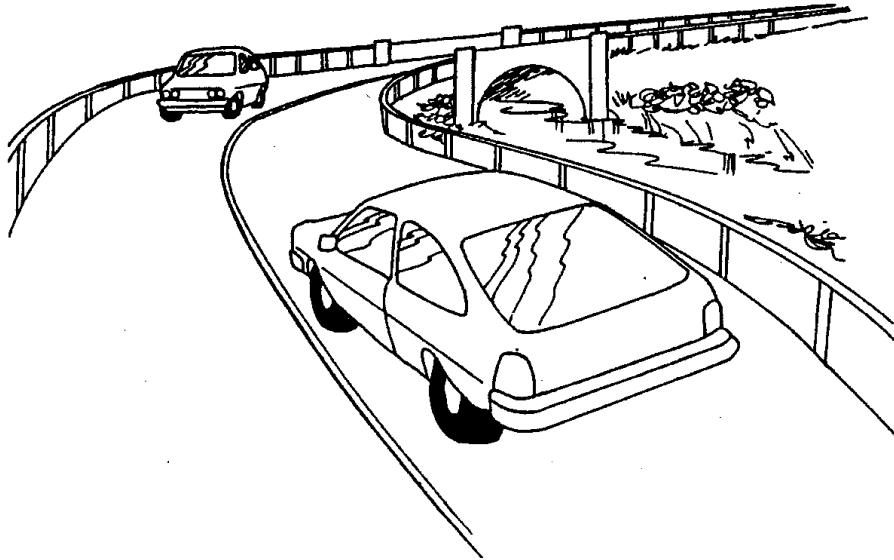

- Less than one car width to one side
- Roadway ahead gets narrower

Changes in Space to Sides: Highway Conditions

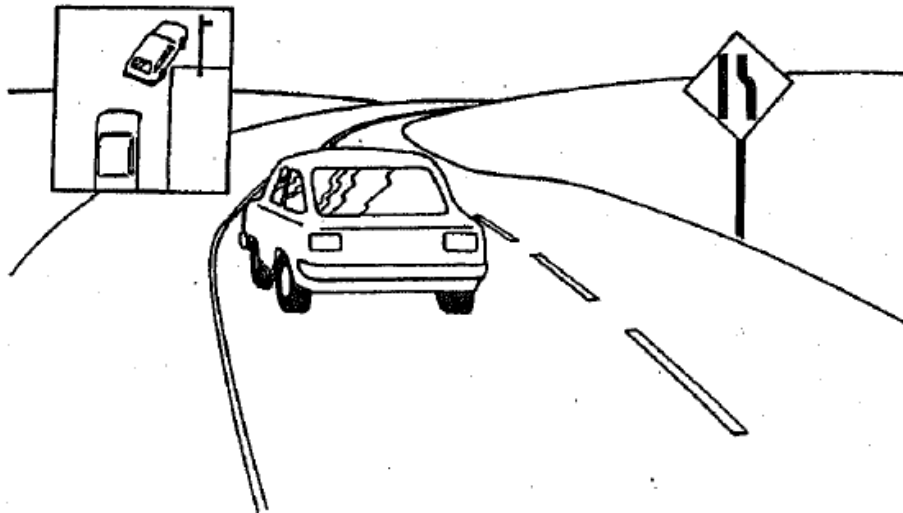

- Number of lanes, width of pavement, width of shoulders, guard rails
- Embankments, fencing, posts, trees, snow bank, rock slide, barricades

Changes in Space to Sides: Other Traffic

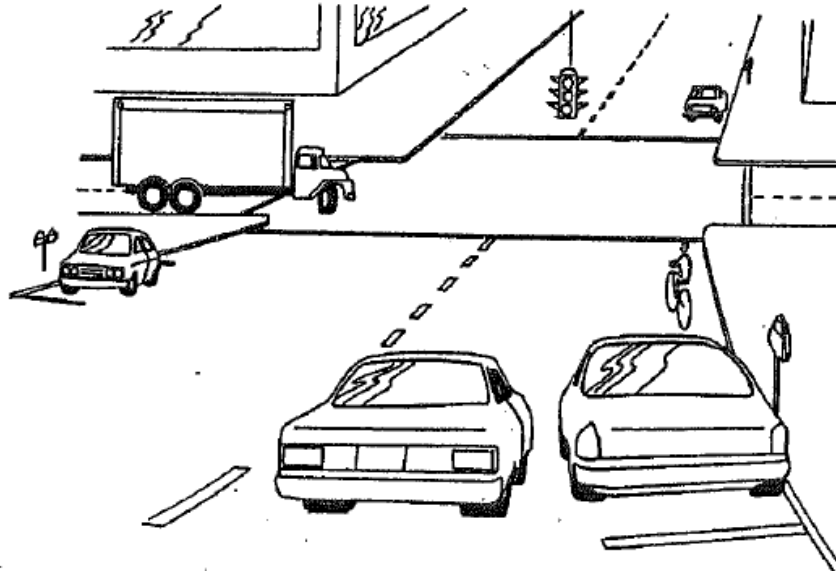

- Oncoming line of cars, cars waiting to turn left
- Parked delivery trucks, turning trucks, bikes, pedestrians, stalled cars

Less Sight Distance Ahead: Less View to Sides

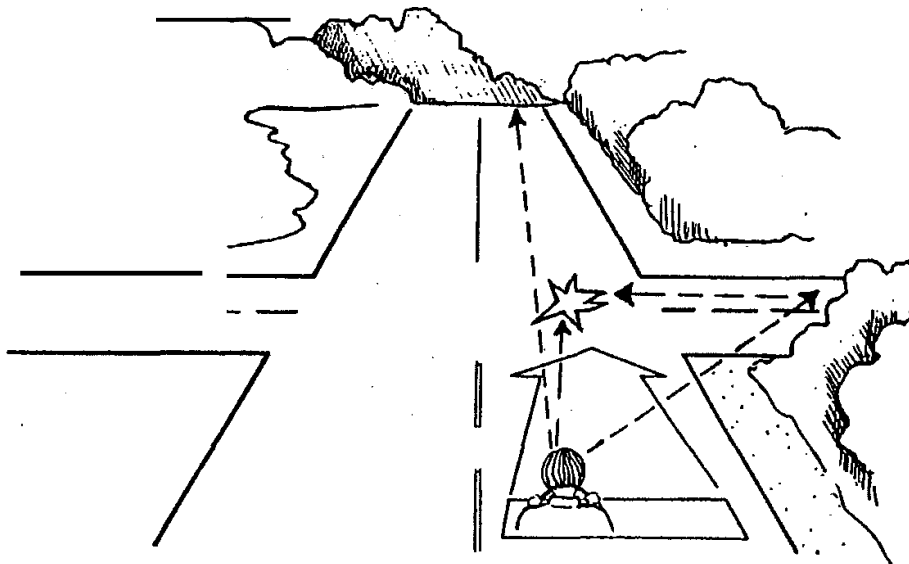

- Present speed becomes unsafe for changes in sight distance or view to sides
- Stopping distance becomes greater than seeing distance

Changes in Sight Distance or View to Sides: Highway Conditions

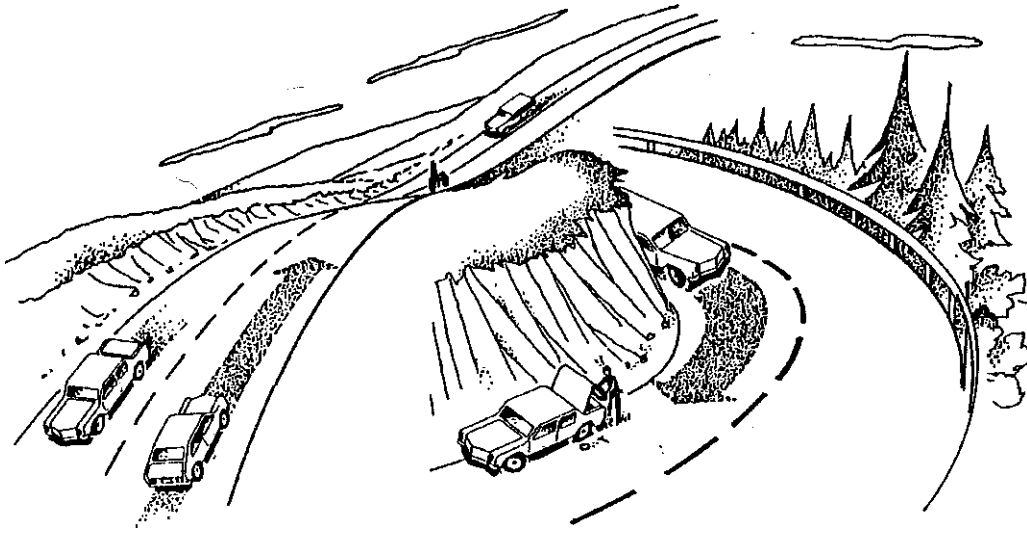

- Hills, curves, dips in road, embankments
- Signs, shrubs, farm crops, buildings, snow banks

Changes in Sight Distance or View to Sides: Other Traffic

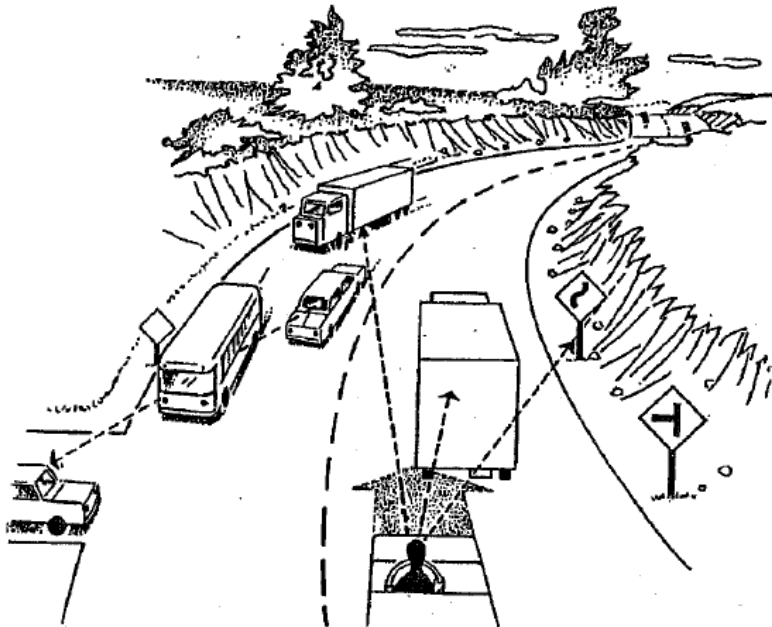

- Large trucks or buses ahead, cars or trucks standing, parking, turning or waiting to turn

Clues to Hidden Side Roads

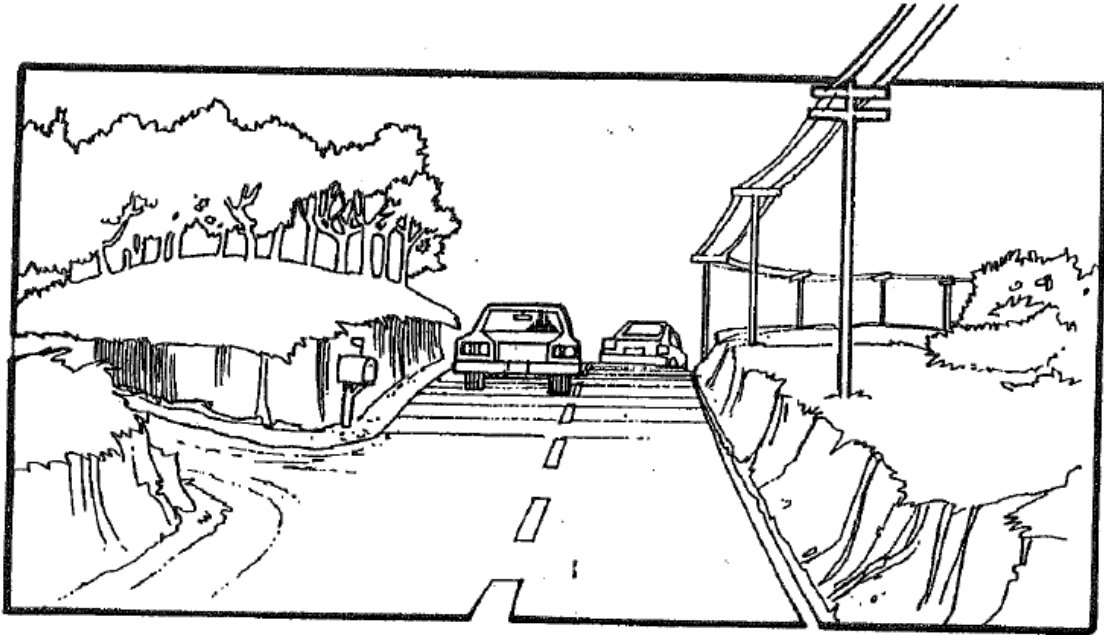

- Mailboxes, telephone or electricity lines, farm house, cloud of dust

Areas of Less Traction

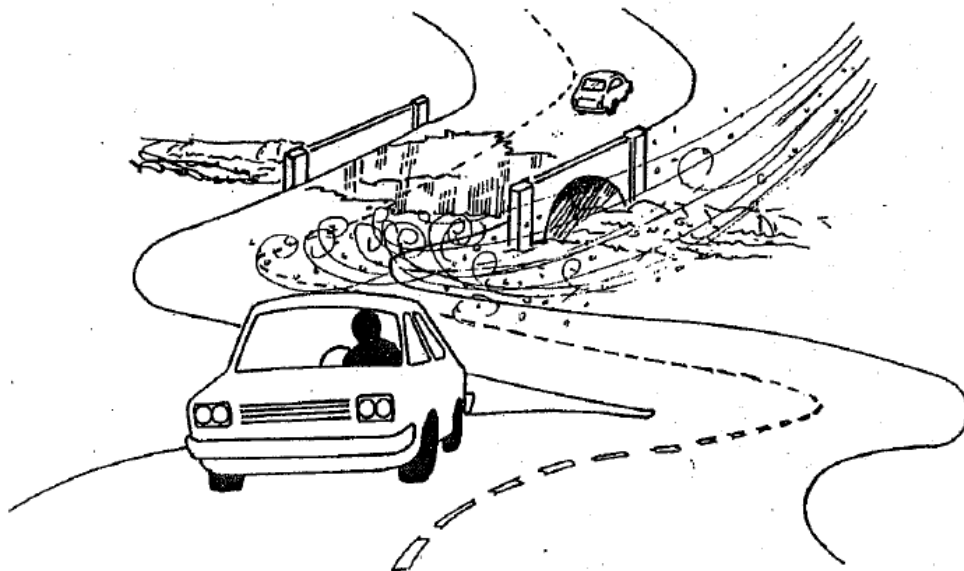

- Less grip of tires on road surface, less ability to control car

Changes in Traction: Roadway Conditions

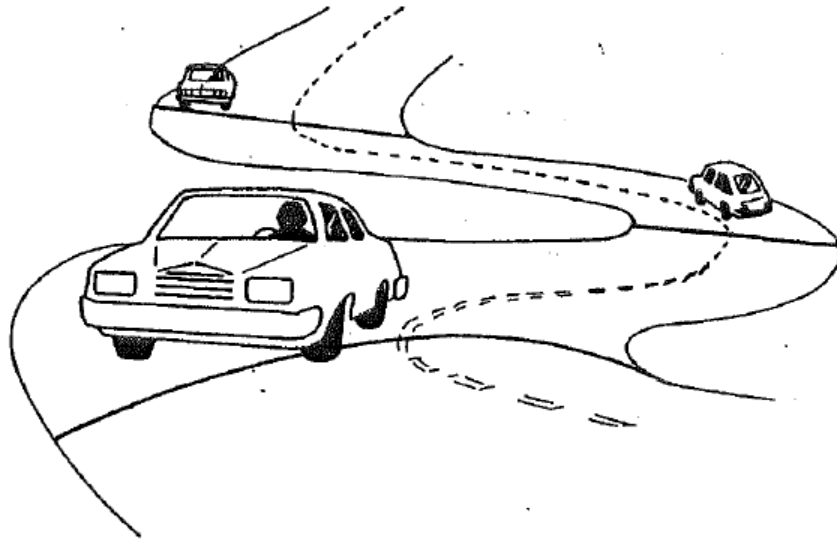

Slope of Surface -- flat, high in middle, low on one side

Shoulders -- not level with pavement, soft, rough

Type of Surface -- concrete, blacktop, brick, gravel

Surface Roughness -- chuck holes, railroad tracks, sewer covers

Changes in Traction: Surface Materials

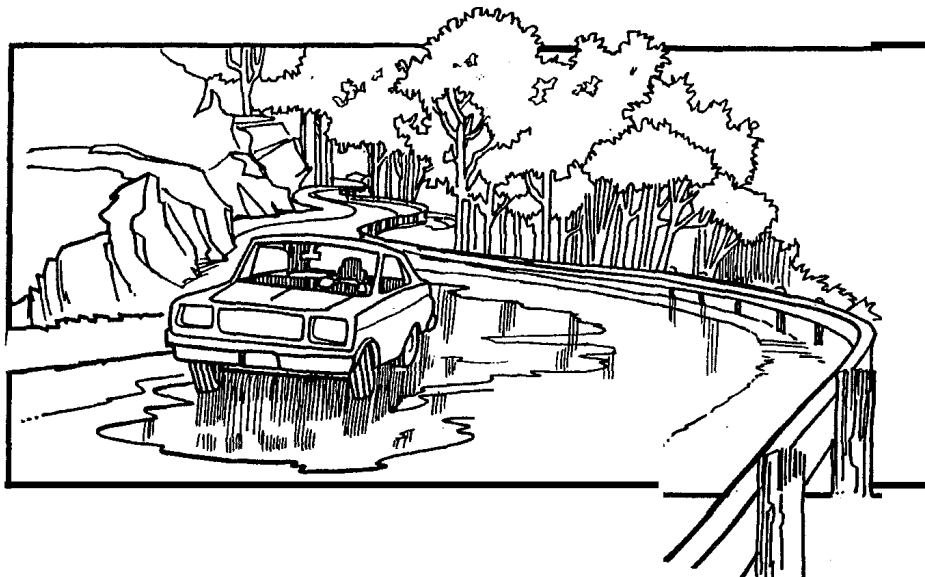

- Sand, mud, rock slides, oil, tar, water, ice, snow, frost

Session Four: Identifying Other User Actions

Time:

Minimum of one class period or maximum of two class periods.

Purpose:

Identifying and predicting the probable actions of other users is extremely difficult. Of the three categories, this is the more difficult one in relation to identifying and predicting what the other user is going to do. By first identifying traffic controls and highway conditions, it is sometimes easier to predict the probable actions of the other user. There are other user clues that can also be identified, and the more clues identified, the more accurate the prediction. This session will introduce the beginning driver to practice identifying these various clues. The driver education text should serve as a resource for this session, and the most appropriate parts would include:

1. Sharing the Roadway with Other Users
2. Driving in Different Environments

Materials/Equipment:

- Perceptual Driving Program, Session Four
- Driver Education Text Selective Worksheets Slide Projector
- Screen
- Overhead Projector or Power Point
- CD Rom -Module III, Perception and Driving Strategies for Different Environments
- Computer with CD capability and LCD Projector

Session Objectives

1. Students can identify vehicle condition and performance clues to better predict the actions of other drivers;
2. Students can identify clues to changes in vehicle movement;
3. Students can identify driver clues that enable one to predict their probable actions;
4. Students can identify motorcyclist clues in regard to their probable actions;
5. Students can identify bicyclist clues in regard to their probable actions; and
6. Students can identify pedestrian clues in regard to their probable actions.

Session Outline:

1. Vehicle Condition and Performance Clues
 - a. Body Style and Size
 - b. Condition of Vehicle Body
2. Clues to Changes in Vehicle Movement
 - a. Signals and Front Wheels
 - b. Location and Attempted maneuver
 - c. Lights and Exhaust

- d. Body Angle and Tire Squeals
- 3. Driver Clues to Probable Actions
 - a. Age and Condition
 - b. Activity of Person
- 4. Clues to Motorcyclist Actions
 - a. Age and Conditions of Rider
 - b. Type and Size of Motorcycle
 - c. Location and Activity
- 5. Clues to Bicyclist Actions
 - a. Age and Condition of Rider
 - b. Type and Size of Bike
 - c. Location and Activity
- 6. Clues to Pedestrian Actions
 - a. Age and Condition of Pedestrian
 - b. Location and Activity
- 7. Flash-Slide Activity for Application
- 8. Session Summary

Guidelines for Conducting Session Four

Teaching Point	Rationale
Introduce session.	<p data-bbox="586 974 740 1003">Introduction</p> <p data-bbox="586 1045 1479 1171">You are now ready to practice the identification of Other User actions. Once you have perceived the traffic controls and highway conditions, it is usually easier to identify the probable actions of other users.</p> <p data-bbox="586 1213 1474 1409">Identifying and interpreting the actions of other users is one of the most difficult things a driver must do. Other drivers can travel at high speeds, make sudden changes in direction and start or stop quickly. Therefore, the more evidence or clues you can discover quickly about other users, the better you can predict whether or not they are likely to move into your intended path of travel.</p> <p data-bbox="586 1451 1463 1577">In most situations, only one of the other user's actions could cause him or her to close on your path of travel. This simplifies your job of identification, since you have to look for evidence of only one action rather than several.</p>
Show 0-A Master. Show each objective as it is introduced.	<p data-bbox="586 1577 1474 1713">In this session, you will be expected to demonstrate the following objectives: Show and discuss each objective from 0-A Master. Now, let's take a look at all the clues for which we should be looking- and in an orderly way.</p>
Show 0-B Master.	<p data-bbox="586 1713 849 1745">Body Style and Size</p>

Teaching Point	Rationale
Ask class for other clues in relation to body style and size.	<ul style="list-style-type: none"> • Large trucks, buses and motor homes take up more space when turning. They have reduced pickup and longer braking distances. • City buses and taxis may be in a hurry and will expect and take the right-of-way. • Drivers of sport models and high performance cars may make quick stops, starts and turns. • Small economy compacts may have less pickup and less braking capability.
Ask class to explain how these clues help one to predict certain actions.	<p>Condition of Body</p> <ul style="list-style-type: none"> • Bent-up fenders and improper tire inflation could be clues to a poor driver; • An overloaded car could have steering and braking problems; • The driver of a car with an out-of-state license may be unfamiliar with the area which could lead to sudden changes or errors; • Glass that is dirty or partially obstructed by ice, snow or objects inside the car may indicate a driver with poor visual habits; • Body lean on a turn may indicate too fast a speed and possible loss of control; and • A raised hood or trunk lid usually means the car is disabled.
Show 0-C Master.	Signals and Front Wheels
Ask class to explain what these various clues mean.	<ul style="list-style-type: none"> • Are turn signals, back-up lights or horn being used? • How long have the signal lights been activated? • What is the direction of the front wheels? <p>Location and Attempted Maneuver</p> <ul style="list-style-type: none"> • Is the vehicle in the turning lane, in the passing lane, next to curb or on the shoulder? • Is the vehicle centered in the lane or drifting to one side of it? • Is the car tailgating or driving in your blind spot? • Is there time and space for completion of the maneuver? Do you detect an error? <p>Lights and Exhaust</p> <ul style="list-style-type: none"> • Are the brake lights or four-way flashers on? • Are puffs of smoke coming from a moving car or the exhaust coming from a parked car? <p>Body Angle and Tire Squeals</p> <ul style="list-style-type: none"> • Does the front-end nose down? • Does the back-end squat or the tires squeal? • What does the body lean of the oncoming vehicle in the curve tell you?
Show 0-D Master.	Age and Condition of Driver
Have class identify other Driver Clues.	<ul style="list-style-type: none"> • An older person may be slow to react. • A younger person may be inexperienced and take risks. • A short person could have sight problems. • Does driver appear confused, sleepy or impaired?

Teaching Point	Rationale
<p>We are using the three key questions: What or who? Where is it? What's it doing?</p>	<p>Activity of a Driver</p> <ul style="list-style-type: none"> • Does the driver make eye contact? • Is the driver distracted by talking, smoking, eating, map reading, scenic viewing, or tending to children?
<p>Show 0-E Master.</p>	<p>Age and Condition of Operator</p> <ul style="list-style-type: none"> • Is the driver young or old? • Is the driver impaired? • Is there a passenger? • How are they dressed? • Is the bike overloaded?
<p>Have class identify other clues.</p>	<p>Type and Size of Bike</p> <ul style="list-style-type: none"> • Larger cycles can stop or pick up speed more quickly. • Is the bike too large for rider? • Is it a racing bike, sport bike or street bike? <p>Location and Activity</p> <ul style="list-style-type: none"> • What is the bike's position within the lane? • What are the road conditions ahead of the bike? • Are two or more bikes traveling together? • How is the bike being handled? Is it weaving, leaning properly, turning, etc.? • Are the lights on? • Where is the rider looking?
<p>Show 0-F Master. Have class identify other clues.</p>	<p>Age and Condition of Bicyclist</p> <ul style="list-style-type: none"> • Children may not know laws. • The person may be impaired. • Elderly rider may be non-driver or have slow reaction. • Clothing and equipment. • Children may be playing. <p>Type and Size of Bike</p> <ul style="list-style-type: none"> • Is it too small or too large for the person? • Is it a racing bike, a multiple-speed bike or play bike? • Is it equipped for night riding? <p>Location and Activity</p> <ul style="list-style-type: none"> • Is it close to curb or in middle of street? • Is it coming to a sewer drain or pot hole? • Is it moving, weaving or parked? • Are there two or more in a group? • Is there eye contact?
<p>Show 0-G Master. Have class identify other clues.</p>	<p>Age and Condition of Pedestrian</p> <ul style="list-style-type: none"> • Children may lack knowledge of laws. • Children may be playing. • Elderly person may be impaired or a non-driver. • Packages or an umbrella may cause poor vision. • Physically disabled.

Teaching Point	Rationale
Remember to use the three questions: What or who? Where is it? What's it doing?	Location and Activity <ul style="list-style-type: none"> • Is person close to curb, in street or between parked cars? • Is the person moving toward or away from street? • Is person standing, walking, talking or running? • Will children dart out? • Where is person looking? Eye contact? • Time of day.
Repeat same procedures as used before.	Now it is time to search for other user clues in real settings. Here are your answer sheets for our flash-slide activity. Once again, the first two slides are demonstration slides for you to only search for other user clues.

0-1: Search for Other User Clues. Ready?

After the slide is on the screen, select individuals to identify other user clues, e.g.

- Parked vehicle on right with hazard flashers on and unoccupied.
- Pedestrian in street on right, looking at us, and not in crosswalk.
- Oncoming vehicle in lane one with left turn signal activated.
- Ongoing vehicle with brake lights activated.
- Pedestrian crossing intersection with traffic light.

Once these clues are identified, ask the following questions:

- A. The parked car on the right has four-way flashers activated. True
- B. There is a pedestrian in the street in our lane of traffic. True
- C. The oncoming vehicle has its left turn signal activated. True

0-2: Search for Other User Clues. Ready?

After the slide is on the screen, select students to identify other user clues, e.g.

- Vehicle in lane two with brake lights on, centered in the lane, and following too close.
- Vehicles in lane one with no brake lights or signals and all centered in the lane.
- Vehicles will be merging from the right.
- Vehicle on the right with left turn signal flashing.

Once these clues are identified, ask the following questions:

- A. The ongoing vehicle in lane two has brake lights activated. True
- B. The vehicle in front of you appears to be exiting. False
- C. The vehicle in the merging lane has its left turn signal activated. True

0-3: Search for Other User Clues. Ready?

- A. The parked car on the right is occupied. True
- B. The oncoming vehicle is partially in your lane. False
- C. A parked vehicle on the left is about to enter traffic. False

Put 0-3 back on the screen for scoring and discussion.

- A. True, the vehicle is occupied with a driver and all clues tell us that he should not be a problem in relation to our path of travel, e.g. his position stays static and the front wheels of the vehicle are turned in.
- B. False, the oncoming vehicle is close to the imaginary center line because he is moving away from the parked cars.
- C. False, there is nothing telling us that this will occur.

0-4: Search for Other User Clues: Ready?

- A. The ongoing truck has brake lights on. True
- B. The oncoming truck will be turning left. True
- C. The vehicle that just entered our highway is going into lane one. False

Put 0-4 back on the screen for scoring and discussion.

- A. True, truck is centered in its lane and it appears the truck will continue straight.
- B. True, oncoming tanker truck has its left signal on and is in the turning lane.
- C. False, the car that entered the highway from the left appears to be steering into lane two.

0-5: Search for Other User Clues...Ready?

- A. The ongoing vehicle has brake lights on. False
- B. The parked vehicle on right appears to be ready to enter our lane of travel. True
- C. The oncoming vehicle is turning to its right. True

Put 0-5 back on screen for scoring and discussion

- A. False, driver of ongoing vehicle might not be aware of the occupied vehicle on right with brake lights showing.
- B. True, parked vehicle on right shows activity with a driver and brake lights.
- C. True, the first oncoming vehicle is turning to its right. Also, there is no activity with parked vehicles on left side and there doesn't appear to be any vehicles ready to enter our street.

0-6: Search for Other User Clues... Ready?

- A. The ongoing vehicle in our lane has brake lights on. True
- B. The ongoing vehicle in lane one is changing to lane two. True
- C. There is a vehicle on the right shoulder. True

Put 0-6 back on screen for scoring and discussion.

- A. True, ongoing vehicle in our lane has brake lights activated and it is centered in the lane.
- B. True, vehicle on our left is changing lanes to its right.
- C. True, there is a vehicle ahead on right shoulder.

0-7: Search for Other User Clues... Ready?

- A. A vehicle is backing from the angle parking spaces on the right. False
- B. A pedestrian is entering the street from the left curb. True
- C. The ongoing vehicle has brake lights on. True

Put 0-7 back on screen for scoring and discussion

- A. False, there are no visual clues to indicate a vehicle is backing or wants to back from its space.
- B. True, the pedestrian is walking toward the street from the left sidewalk, but no parked cars on left appear to be ready to enter traffic nor is there any oncoming vehicles.
- C. True, ongoing vehicle is stopping for stop sign and appears to be preparing to turn right.

You are now ready to proceed with the three test slides and you should follow the same procedure as you did in the two previous sessions.

0-8: Search for Other User Clues... Ready?

- A. A parked car on right has door partly open. True
- B. The oncoming van is crowding the center line. False
- C. There is an oncoming ambulance. True

Discussion when reviewed

- The door opening on right might force us to move to the left of our lane.
- The oncoming van is centered in its lane and there doesn't appear to be any activity with the parked cars on left that might force the van toward us.
- There is an oncoming ambulance and it appears to be turning to its left and there are brake lights showing on vehicles in front of us.

0-9: Search for Other User Clues..... Ready?

- A. The dump truck is centered in its lane. False
- B. The tank truck has brake lights on. False
- C. The red car on right is following too close. True

Discussion when reviewed.

- The dump truck appears to be making a right lane change and possibly preparing to exit. It should be noted that the truck's load might not be sufficiently secured.
- The tank truck in its lane is centered and might have to reduce speed for the dump truck coming into its lane.
- The driver in the red car is tailgating and if the tank truck starts to slow, this driver might swerve into our lane. We are NOT in the driver's blind spot.

0-10: Search for Other User Clues... Ready?

- A. There is a pedestrian in the crosswalk. True
- B. The truck is on the lane line. True
- C. The second oncoming vehicle is on the lane line. True

Discussion when reviewed.

- There is a pedestrian in the crosswalk on our right and he is looking toward us.
- Car in right lane has brake lights on, he could possibly come into our lane if he doesn't want to slow for truck or there might be activity in parked cars on right which we can't see.
- Truck in the right lane is on or over the lane line.
- The second oncoming vehicle is on the lane line, he could possibly be moving into the oncoming lane closer to us.
- Third oncoming vehicle is a truck and is in the inside lane and possibly turning left.

Session Summary

- Identifying and interpreting the actions of other users is one of the driver's most difficult tasks. You may wish to think of yourself as a detective looking for evidence.
- The most important clues to look for are those that would cause other users to become a conflict in your projected path of travel.
- The style, size and condition of the other vehicle tell both about the person's driving habits and about the probable vehicle performance- acceleration, steering and braking capabilities.
- Clues to changes in direction or changes in speed may be quite obvious- signals or brake lights. There may be more subtle ones such as exhaust smoke and the angle of the vehicle body.
- When searching for other user clues, ask yourself three main questions: "What or who is it", "Where is it?", and "What is it doing?"
- When possible, always try to make eye contact with the other user.

Objectives

- Identifying vehicle condition and performance clues
- Identifying clues to changes in vehicle movement
- Identifying driver clues
- Identifying motorcyclist clues
- Identifying bicyclist clues
- Identifying pedestrian clues

Vehicle Condition and Performance



Body Condition or Out-of-State License

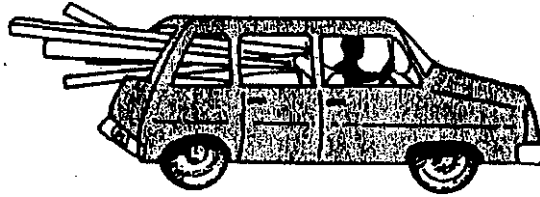

Improper – Overloaded

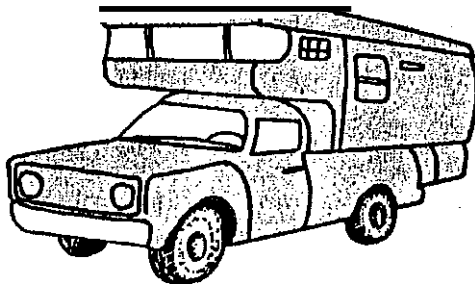

High or Low Performance

Clues to Change in Vehicle Movement

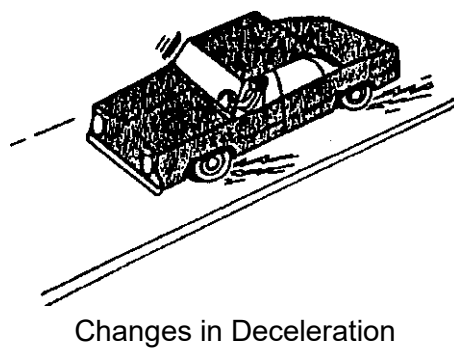
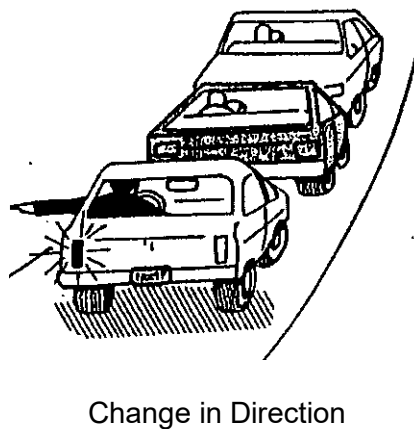
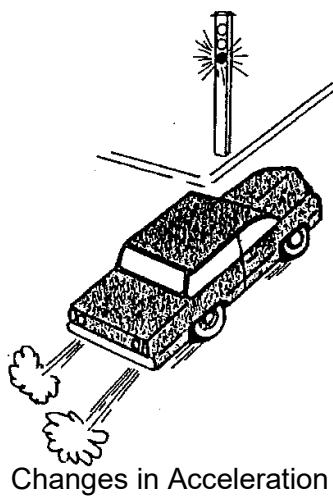

Driver Clues to Probable Actions



Activity of Driver



Condition of Driver

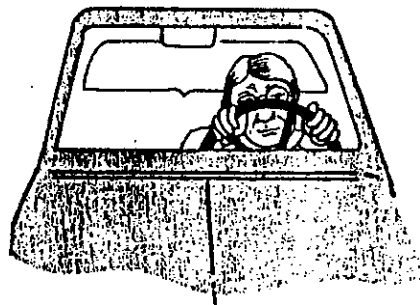

Age or Posture of Driver

Clues to Motorcyclist Actions

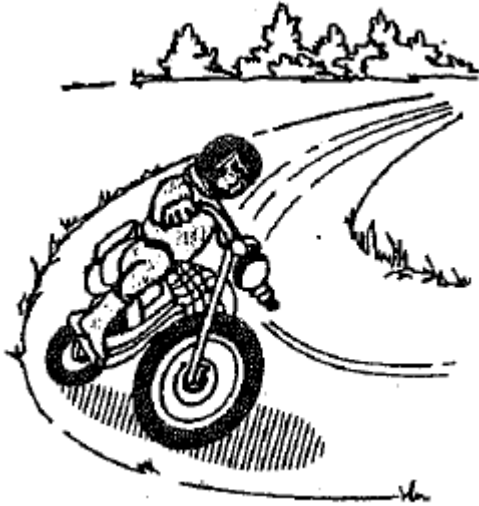

Activity – Learning

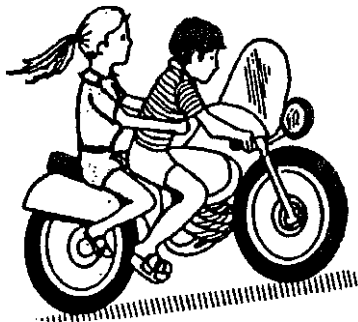

Age and Way Dressed



Location as Related to Condition of Pavement Ahead

Clues to Bicyclist Actions

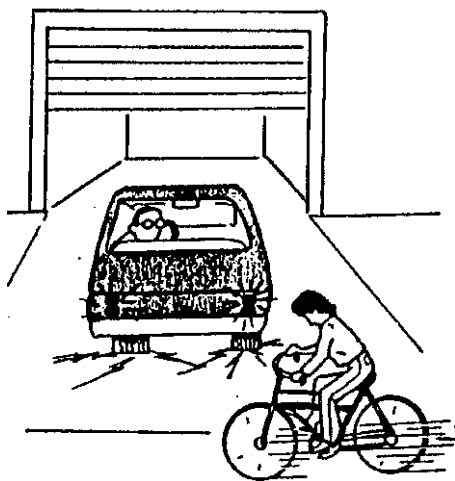

Location of Bicycle

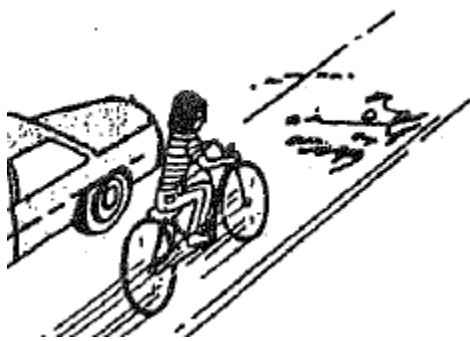

Roadway Conditions Ahead of Bicyclist

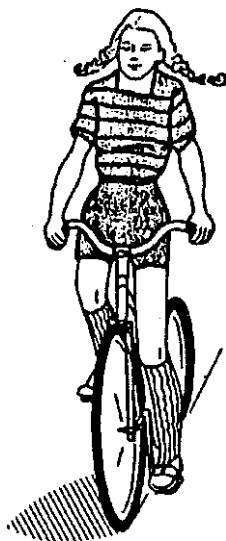

Type of Rider

Clues to Pedestrian Actions



Location

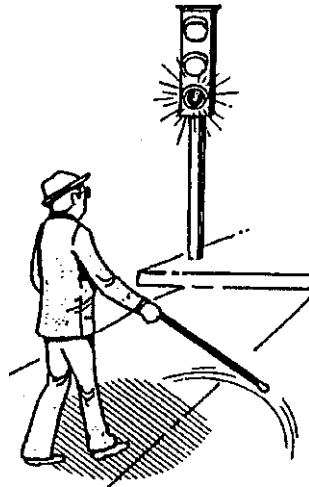

Age and Condition

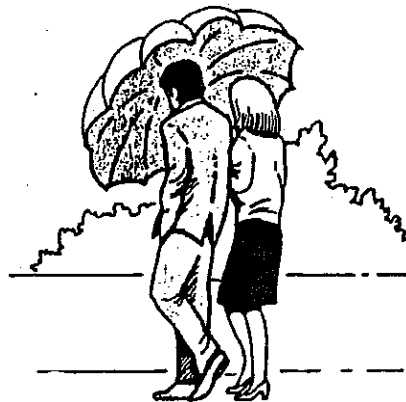

Activity

Session Five: Identifying All HTS Events

Time:

One class period.

Purpose:

The beginning driver is now ready to identify all three categories as each relates to his/her projected path of travel. The beginning driver should identify traffic controls first, highway conditions second and then other user clues. Searching should be side-to-side and out as far as possible; and once again, only identify those items that relate to their projected path of travel.

Materials/Equipment:

- Problem Solving Skills for Drivers, Session Five
- Selected Work Sheets
- Slide Projector
- Screen
- CD ROM-Module III, Perception and Driving Strategies for Different Environments
- Computer with CD capability and LCD Projector

Session Objective:

When exposed to a highway and traffic situation on a screen for five seconds or less, students can identify the traffic controls, the roadway conditions and the clues to other user actions.

Session Outline:

1. Introduction
2. Flash-Slide Activity for Application
 - a. Demonstration Slides
 - b. Practice Slides
 - c. Test Slides
 - d. Final Score for Flash-Slide Sessions
3. Summary for First Five Sessions

Guidelines for Conducting Session Five

Teaching Point	Rationale
Introduce session	Introduction For training purposes, you have practiced searching for HTS elements in only one major group at a time. However, as you search the traffic scene in actual driving situations, you must be able to search all three groups at almost the same time. For example, as you come to an intersection, you search all four comers for signs and signals. At the same time, you check the

Teaching Point	Rationale
	<p>sharpness of the curbing's and the road surface for reduced traction. As you check for visibility problems, you observe other users for clues to their probable actions. Is a car speeding up to beat the light change? Will pedestrians delay turning movements? Is the car behind tailgating? Are any of the cars parked at the end of block about ready to exit?</p> <p>With this final set of flash-slides, then you will combine all three searching habit into one. We are ready to "put it all together." For each picture, I will tell you whether to search for two or all groups. We will use the same procedures as we did in the three previous sessions. There will be two Demonstration slides, five Practice slides and three Test slides.</p>

A-1: Search for All Groups: Ready?

After the slide is on the screen, select individuals to identify the various groups, e.g.

- You are on a one-way street, Do Not Enter sign on right, traffic light ahead with two lanes.
- Limited view to the left and right at intersection, approaching an area of less space caused by pedestrian and bicyclist.
- Pedestrian is looking at us, bicyclist going wrong way on one-way street and looking at us.

Once all the groups are identified, ask the following questions:

- | | |
|---|------|
| A. You are on a one-way street | True |
| B. You are approaching an area of less view to the sides. | True |
| C. The pedestrian and bicyclist are looking at us. | True |

A-2: Search for Controls and Other User Clues...Ready?

After the slides in on the screen, select students to identify the categories

- Two-lane and two-way roadway, warning signs indicating traffic light ahead and left curve, stale green light
- Van approaching our roadway from the right, oncoming vehicle crowding the center line.

Once all the groups are identified, ask the following questions:

- | | |
|---|------|
| A. You are approaching a traffic light. | True |
| B. A vehicle is approaching your road from the right. | True |
| C. The oncoming vehicle is close to the center line. | True |

A-3: Search for Controls and Highway Conditions: Ready?

- A. The left lane will end. True
- B. You have good sight distance. True
- C. The right shoulder is not level with the roadway. False

Put A-3 back on screen for scoring and discussion.

- A. True, two controls tell you that the left lane will end and they are the warning construction signs and the large arrow ahead on left. What type of actions should this trigger the driver to begin, e.g., visual search around the vehicle and perhaps speed reduction?
- B. True, the environment allows excellent sight distance at this point and at this point good space, but will be approaching less space
- C. False, the right shoulder is even grade with the roadway and provides adequate space and looks like good traction. This would not be true of the median's space.

A-4: Search for All Groups and Route 286... Ready?

- A. Route 286 is a state highway. True
- B. You are approaching a right merge area. True
- C. The truck ahead is centered in its lane. False

Put A-4 back on screen for scoring and discussion.

- A. True, the keystone symbol tells you that it is a Pennsylvania highway, also you are on a two-lane one-way roadway with median to left and controlled access from light.
- B. True, warning sign indicating merge and visually see access road from right, you have good sight and view to side and also good space. Shoulders appear to have less traction. What should the warning sign trigger in regards to driver actions? Visual search behind and to the right.
- C. False, truck is close to lane line and this might be caused by vehicle entering from right this is not visible in picture.

A-5: Search for Highway Conditions and Other User Clues. Ready?

- A. You are in an area of less space. True
- B. You have good visibility. False
- C. The van is double parked. True

Put A-5 back on screen for scoring and discussion.

- A. True, area of less space caused by parked cars on both sides of street, snow at sides and van.
- B. False, you have poor view to the sides near the van and sight distance is not real good.
- C. True, there is no driver in the van, only one light was flashing on front of van, ground search will show what appears to be legs behind the van. Cannot make eye contact with anyone around van.

A-6: Search for Controls and Other User Clues: Ready?

- A. You are on a two-lane, two-way roadway. True
- B. There is a bike lane to your right True
- C. There is a pedestrian ahead on the right. True

Put A-6 back on screen for scoring and discussion.

- A. True, double yellow line to the left.
- B. True, bike lane on right with space beyond the lane line and symbols designating special use. There also appears to be a bike lane on the left side of the road.
- C. True, a good sight distance with side to side search will show a person on right side of highway.

A-7: Search for All Groups ... Ready?

- A. You are on a two-lane, two-way roadway. True
- B. You are approaching an area of less space. True
- C. The bicyclist is riding towards you. False

Put A-7 back on screen for scoring and discussion.

- A. True, double yellow line to left. There are also chevrons ahead on right showing a left curve.
- B. True, less space is caused by dynamic situations which are utility workers, vehicles and bicyclist. You also will have less view to the right at the next intersection.
- C. False, bicyclist is riding away from you and will need attention after you get by the utility workers and vehicles.

You are now ready to proceed with the three test slides and you should follow the same procedures that you used for the previous three sessions.

A-8: Search for All Groups and Route 61 North ... Ready?

- A. The intersection is controlled with a traffic light. True
- B. You will be approaching an area of less space. True
- C. Vehicles to the left of you appear to be turning left. True

Discussion when reviewed.

- Route 61 is a US Highway, to go North stay in lane you are in, traffic light is green, right turn lane and left turn lane, keep right Regulatory Sign, and no-passing zone after intersection.
- There is good space where you are approaching intersection, after intersection the space diminishes because of bridge, good sight distance and view to the sides.
- Vehicles in the left turning lane are close to center line and it appears that left signal is on, vehicle in right turn lane has brake lights on and to the right side of lane, and vehicles ahead have brake lights on.

A-9: Search for Controls and Highway Conditions ... Ready?

- A. You are on a two-lane, one-way roadway. True
- B. You are approaching a four-way intersection. True
- C. There is a driveway or road to the right. True

Discussion when reviewed.

- The yellow line is on left with the other lane lines white, warning sign showing intersection. What should this trigger on driver's part? This is a divided highway with cross traffic.
- This is an area of good space and sight distance, view to side is restricted and there is a driveway on roadway to right, also appears to be one to left.

A-10: Search for Controls and Other User Clues ... Ready?

- A. You are approaching a pedestrian crosswalk. True
- B. A parked vehicle on right has back-up lights on. True
- C. There is a pedestrian between two of the parked cars. True

Discussion when reviewed

- Overhead warning sign showing crosswalk along with flashing signal, pavement markings showing crosswalk, multiple lane usage at intersection.
- Parked car on right with brake lights on and in reverse, pedestrian leaving street by walking toward right curb, oncoming vehicle centered in its lane, ongoing vehicles have brake lights activated.

The mental processes or skills you have been using to choose an answer is the most important part of this flash-slide training program. Hopefully, you will be able to apply these skills in the training car. Remember, you should be able to continue making progress after the course and improve your identification skills as it relates to your projected path of travel.

Summary of First Five Sessions

- Perception is a selective process involving the senses and the brain. It can be improved with directed practice.
- It is most important that you are continually projecting a 20-30 second projected path of travel. Then, you can relate all events to it with efficient searching habits.
- Know what to look for as you search for traffic controls, highway conditions, and other users.
- It is the changes in space, visibility and traction that are the primary conditions of the highway that need to be identified at all times.
- When searching for other user clues, a key question is: "What action will the other user have to take that will cause a conflict to take place on my projected path of travel?"

Session Six: Identifying Closing Probabilities

Time:

Minimum of two class periods.

Purpose:

Correctly judging or predicting what the other user will do in relation to a driver's projected path of travel can mean the difference between a safe and efficient response, versus a sudden emergency response that can result in a close call, or worse, a collision. Most drivers are good at identifying and predicting the obvious, but the obvious is not what causes emergency situations. Using a systematic search pattern, remembering and practicing four basic guides will better enable a driver to correctly judge or predict the probable actions of other users. The driver education text should serve as a resource for this session, and the most appropriate parts would include:

1. Driving in Different Environments
2. Sharing the Roadway with Other Users

Materials/Equipment:

- Perceptual Driving Program, Session Six
- Driver Education Text
- Selective Work Sheets
- Overhead Projector or Power Point
- Slide Projector Screen Chalkboard
- CD Rom -Module III, Perception and Driving Strategies for Different Environments
- Computer with CD capability and LCD Projector

Session Objectives:

1. Students can identify and explain the three parts of the projected path of travel;
2. Students can demonstrate their ability to measure following distance with a time measurement;
3. Students can demonstrate their ability to measure stopping distance with a time measurement;
4. Students can demonstrate their ability to measure sight distance with a time measurement;
5. Students can identify probable errors of other users;
6. Students can demonstrate how to determine a high or low probability of conflict with other users; and
7. Students can demonstrate their ability to determine when a potential conflict might occur and how much of their projected path of travel will be used by the other user.

Session Outline:

1. Introduction
2. Identify the three parts of travel path
 - a. Following distance
 - b. Stopping distance
 - c. Visual lead
3. Identify probable errors of other users
 - a. Failure to observe traffic laws
 - b. Improper responses to highway conditions
 - c. Improper responses to other user actions
 - d. Improper control actions of other users
4. Evaluate conflict probabilities of other users
 - a. Evidence for and against conflicts
 - b. Driver actions are limited
 - c. Identify low chance of conflict
 - d. Identify high chance of conflict
5. Identify probable points of conflict
 - a. Judge speed of closing
 - b. Judge amount of space required
 - c. Judge where to expect closing
6. Case studies for application
 - a. Diagrams
 - b. Traffic scenes

Guidelines for Conducting Session Six

Teaching Point	Rationale
Introduce session	<p>A competent driver has the ability to select a safe path of travel. A safe path of travel is one that is free from hazards at the time when a driver will want to use such a pathway. It is a pathway that has enough clear space for driving a vehicle. When there is not enough clear space ahead of a vehicle, there is a good chance for a collision.</p> <p>You have learned how to identify highway and traffic events and the clues related to them. This is the first step toward selecting a safe path of travel. Now you'll need to learn how to judge what other users will do. Will they move into your intended path of travel at a time you had planned to be there? The key question to ask would be is my path clear or not clear?</p>
Show E-A Master	The objective of this session will be to identify the conflict probabilities of other users in your path of travel. You will accomplish this overall objective by demonstrating the following objectives: Use the objectives from E-A Master.
Uncover each objective as it is discussed	You will be provided with four general guidelines that relate to the objectives, which can help you evaluate and identify the probable actions of other users. Students will practice these using potentially hazardous scenarios.

Teaching Point	Rationale
Show E-B Master	<p data-bbox="586 226 781 258">GUIDELINE# 1</p> <p data-bbox="586 296 1081 327">Identify the Three Parts of Travel Path</p> <p data-bbox="586 327 1490 464">The first guideline is to show how to apply the three parts of the projected path of travel. The purpose of evaluating highway and traffic events is to judge whether or not you have a clear path of travel. It will help you to picture the three parts of the path of travel.</p> <p data-bbox="586 499 1520 636">The first is following distance, second is stopping distance, third part is visual lead. These distances will vary with the size and capability of your vehicle. They will also vary with the weather conditions and the conditions of the roadway surface.</p> <p data-bbox="586 667 829 699">Following Distance</p> <ul data-bbox="634 699 1520 1234" style="list-style-type: none"> • Following distance is measured in number of seconds. It is very easy to Learn and to practice, e.g., when the vehicle you are following passes a fixed reference point, you begin counting one thousand one, one thousand two, etc., and you stop counting when the front of your vehicle reaches the reference point. The fixed reference points can be signs, trees, shadows on the road surface, marks on the road surface, etc. The key thing is that it is a "fixed" reference point • Following distances with a standard motor vehicle can vary and distances should be determined with the following formula: <ol data-bbox="634 1037 1487 1234" style="list-style-type: none"> 1. Speeds up to 40 mph, allow 2 seconds; 2. Speeds in excess of 40 mph, add one second; 3. For inclement weather, add one second; 4. For night driving or low visibility, add one second; and 5. For ice or packed snow, add at least four seconds to the basic formula. <p data-bbox="586 1272 1520 1367">Larger vehicles such as trucks and buses use the formula of one second for each ten feet of vehicle length up to 40 miles per hour and then they use all of the other variables listed above.</p> <p data-bbox="586 1404 1138 1436">The Four to Six Second Stopping Distance</p> <ul data-bbox="634 1436 1503 1839" style="list-style-type: none"> • The four to six second stopping distance is that minimum distance you will usually need to be able to stop for an object in the roadway or for other traffic moving across your path. • For most cars, the minimum stopping distance is the equivalent of about four seconds. For less traction, add one or more seconds. • To better understand stopping distance, you should know what comprises or makes up total stopping distance. Stopping distance is comprised of three parts: <ol data-bbox="634 1745 1487 1839" style="list-style-type: none"> 1. Recognition Distance -this is the distance that a vehicle travels from the time a driver is able to identify a real and/or potential hazard and decides what action to take.

Teaching Point	Rationale
	<p>2. Action Distance - this is the distance that a vehicle travels after a decision has been made by the driver and it is executed.</p> <p>3. Braking Distance- this is the distance the vehicle travels after the brakes have been applied. There are many factors that affect braking distance, e.g., speed, weight, traction, mechanical, etc.</p> <ul style="list-style-type: none"> • The first two parts of stopping distance are identified as a Reaction Time/Distance and this is recognized as the sum of Recognition Distance and Action Distance. Many safety specialists recognize .75 or $\frac{3}{4}$ of a second as average reaction time. This is true if a person is totally aware of what to search for and is prepared to respond. Many times, this does not occur and reaction time/distance suddenly becomes 1.5 to 2.0 seconds. • The following is a formula to determine reaction distance. <p>Reaction Distance = speed x 1.47 x reaction time</p> <p>A simpler way is to use $\frac{3}{4}$ of a second as the norm for the reaction time and then take the first digit of the speed you are traveling and add it to the total speed, e.g.</p> <p>35 mph is $35 + 3 = 38$ feet 45 mph is $45 + 4 = 49$ feet</p> <ul style="list-style-type: none"> • The biggest factor affecting braking distance is speed and you need to remember that as speed increases, the braking distance just doesn't increase proportionately, it is squared. <p>The key thing to remember is to never allow a hazard to move into or remain in your stopping zone. Otherwise, a collision will be a sure thing.</p> <p>The 20-30 Second Visual Lead</p> <ul style="list-style-type: none"> • A 12-second visual lead should be considered the minimum sight distance you need but more often than not you are usually afforded a much longer visual lead. A long visual lead will give you time to identify, evaluate and decide what to do before your stopping distance is reached. • Looking far ahead doesn't mean you should not pay strict attention to things in between. • Twelve seconds in the city is about one block. On the highway, it is about a quarter of a mile. • Surprise is involved in practically every collision. The driver with a good visual lead will be able to anticipate problems and therefore prevent surprises. <p>GUIDELINE #2</p> <p>Identify Probable Errors of Other Users</p> <p>The second guideline is to identify probable errors of other users. There are very few collisions that don't involve human error. Once you have learned what errors to expect, you can be more selective about what to look for.</p>

Teaching Point	Rationale
	<p>There is a clever slogan, "Expect the unexpected." But how can one prepare for something that is not expected? Wouldn't a better slogan be "Expect errors and be prepared"? So our second guideline is to identify probable errors of other users. The four types of errors that other users usually make are listed below:</p>
<p>Show E-C Master.</p>	<p>Failure to Observe Traffic Laws</p> <p>Failure to observe traffic laws is one type of driver error. The actions of drivers who know and follow the rules of the road are usually easy to predict. Look for clues to indicate that a rule will not be obeyed. Most errors involve speed and right-of-way laws.</p> <ul style="list-style-type: none"> • Driver fails to yield right-of-way: Does not obey stop or yield sign, runs red light, jumps green light, does not yield to car on the right.
<p>Use the diagrams to help explain.</p>	<ul style="list-style-type: none"> • Driver fails to adjust speed for conditions: approaches stop or yield sign too fast; takes corners too fast; does not adjust speed for changes in highway conditions; does not obey speed limits.
<p>Ask class for other examples.</p>	<ul style="list-style-type: none"> • Driver fails to signal intentions properly: no signal when changing directions; improper use of parking or flasher lights; gives false signals. • Driver fails to observe pavement markings, such as solid lines, arrows and stop lines.
<p>Show E-D Master.</p>	<p>Improper Responses to Highway Conditions</p>
<p>Ask class to give examples.</p>	<ul style="list-style-type: none"> • This is the second type of errors that drivers make. • You have learned how to identify highway conditions that affect the control of your car. Use this knowledge to judge what other users will do when faced with areas of less traction, less space and less visibility. • Look for clues that may indicate the other user does not perceive such changes in conditions.
<p>Show E-E Master.</p>	<p>Improper Responses to Other User Actions</p>
<p>Ask class to give other examples.</p>	<p>This is the third type of driver error that you can expect and search for. When a driver of one vehicle makes an error, the error may not lead to that vehicle closing on your intended path of travel. However, a second vehicle may not notice the error of the first vehicle until too late. Then, the second vehicle may close on your path of travel because of an improper response.</p> <ul style="list-style-type: none"> • This may happen when other vehicles are tailgating or driving in the blind spot of each other. • Other situations may involve cars that are entering or exiting parking stalls and cars that are passing. • You need to realize that two cars which collide in another lane may spill over into your lane.
<p>Show E-F Master.</p>	<p>Improper Control Actions of Other Users</p> <ul style="list-style-type: none"> • This is the fourth type of driver error that you can search for. • Other drivers may panic and swerve or attempt to stop too quickly to avoid a problem. This is especially common on slippery pavements.

Teaching Point	Rationale
Ask class to cite other examples.	<ul style="list-style-type: none"> • Be alert for other drivers who swing wide on turns or who cut turns. • One of the more serious errors is made by the driver who makes a poor recovery after running off the pavement, especially if there is a drop off at the edge of the pavement. • Many drivers will lose control of a skidding vehicle. • Just remember, you cannot control what the other driver does. But you can search for these probable errors and be better prepared for them by managing your space and speed.
Show E-G Master.	<p>GUIDELINE # 3</p> <p>Evaluate Conflict Probabilities of Other Users This is the third guideline to help you better evaluate the actions of other users. Our major concern in driving is to avoid collisions. Therefore, our search and evaluation must be directed first at those hazards or conditions that could result in conflict movements toward our intended path of travel.</p> <p>The chance for other users to move into our projected path of travel will be called conflict probability. Our third guideline to follow, then, is: Evaluate Conflict Probabilities of Other Users.</p>
Show E-H Master	<p>Evidence for and against Conflicts</p> <ul style="list-style-type: none"> • The best way to judge conflict probabilities is to collect evidence (clues) for or against something that could be a conflict in your path of travel.
This is a key concept.	<ul style="list-style-type: none"> • The evidence you collect in searching for other user actions and probable errors can also be used in making evaluations. <p>Driver Actions are Limited</p> <ul style="list-style-type: none"> • Fortunately, there are limited number of actions that others can take that will cause them to come into your path. This simplifies our evaluation procedure. • Drivers of moving vehicles can change directions or speed or both. Speed can be increased, decreased or maintained. They can move right or left. Drivers of stopped cars may also back up. • In most situations, only one of the other user actions could cause a conflict in your projected path of travel. In the case of an oncoming vehicle you must judge whether or not the driver will move left into your path • For drivers of ongoing vehicles, you will need to judge whether they will decrease speed or perhaps brake suddenly. Will the drivers of intersecting vehicles choose a speed that will get them into the intersection at the same time I will get there? • Will the driver of a following vehicle be able to reduce speed when I do? Will the parked vehicle along the roadway accelerate into my path? • The key question for identifying conflict probabilities is: "What action will the other user have to take that will cause the distance between us to be reduced?"

Teaching Point	Rationale
	<ul style="list-style-type: none"> This simplifies our job of evaluation. We only have to look for evidence of the one action rather than several possibilities.
Show E-I Master.	Identify Low Chance of Conflict
Identify the clues that make situations on screen high or low.	<ul style="list-style-type: none"> A low chance of conflict describes a traffic situation in which there is little or no evidence that a conflict will take place. They can be dismissed as unimportant. Examples are: a pedestrian walking away from the street or a parked car with no driver.
Show E-J Master.	Identify High Chance of Conflict
Important point.	<ul style="list-style-type: none"> A high chance of conflict describes a situation in which there is clearly more evidence that the conflict will take place than there is that it will not.
Important point.	<ul style="list-style-type: none"> If there is some doubt, it is usually safest to assume the worst and take appropriate action.
Show E-K Master.	GUIDELINE# 4
	<p>Identify the Probable Point of Conflict Identifying the probable point of conflict is the fourth and final guideline. Traffic collisions happen when two or more persons try to use the same highway space at the same time. If the point of conflict is identified soon enough, then collisions can be avoided.</p> <p>These identifications involve making at least two judgments: the speed at which the other user is closing, and the amount of space the closing will require.</p>
Where is the point on the illustrations?	<p>Judge the Speed of Closing</p> <ul style="list-style-type: none"> Is the speed great enough to cause a closing? Are there clues the other user will increase or decrease speed? <p>Judge the Amount of Space Required</p> <ul style="list-style-type: none"> Some traffic hazards may use the entire pathway; while others may only use a part. A car that is parallel parking may use more than one lane. Two-wheeled vehicles and pedestrians usually use a part of a lane. Vehicles that are unable to complete a turn may block part or all of the lane.
Helps to prepare for the use of answer sheet.	<p>Judge Where to Expect the Conflict</p> <ul style="list-style-type: none"> Will the conflict take place within 12 second area of your path of travel? If more than 12 seconds away- no problem. Will the conflict be within the 4-12 second part of the path? There is time for a proper response. <p>Could the conflict come within the 4 second part of the path of travel or stopping zone? This calls for evasive actions.</p> <p>Summary of Guidelines You have been provided with four guidelines for evaluating and identifying the conflict probabilities of other users. These are:</p> <ol style="list-style-type: none"> Identifying the Three Parts of Travel Paths

Teaching Point	Rationale
	<ol style="list-style-type: none"> 2. Identifying Probable Errors of Other Users 3. Evaluating the Conflict Probabilities of Other Users 4. Identifying the Probable Point of Conflict
<p>Hand out answer sheets and make a copy to put on the screen for discussion.</p>	<p>Case Study Problems</p> <p>To help you apply the four guidelines, case studies will be shown on the screen. These will be diagrams of problem situations or actual traffic scenes. There will be a total of ten case studies, three diagrams and seven traffic scenes. The picture will be put on the screen and it will remain on the screen as you complete the Answer Sheet for Case Study Evaluations. As you carefully examine and evaluate each case study, you should respond in the following manner:</p> <ol style="list-style-type: none"> 1. Determine whether or not there is a probable conflict in your twelve second path. 2. Try to estimate when the probable closing will occur. 3. Attempt to determine how much of your pathway or lane will be used. 4. Justify your prediction by identifying those clues that were processed in arriving at your prediction. <p>After you have had an opportunity to evaluate and respond to the case study, we will discuss your responses. We will try to get a general consensus as to the best answer.</p> <p>Remember, we are interested in the process and not so much the precise answer. Please use all of the visual tools that you have been given and practiced to this point.</p> <p>Teaching Points</p> <ul style="list-style-type: none"> • The first three case studies are diagrams and can be shown using transparencies or power point. The remaining seven are actual traffic scenes and you will need the slide projector. • When using the traffic scenes, you may need to agree to certain assumptions to help set the stage for evaluations the majority of the class can agree on. • You can use all ten case studies or you can reduce the number. If reducing the number, use the first three diagrams and the necessary traffic slides where the students are demonstrating the process in a satisfactory manner. • Once again, the key concept that you are concerned with is that the students demonstrate an understanding of the evaluation process and can apply it. It is your responsibility to help them identify and evaluate as many of the clues that could be available in various case studies. • Remember that all you are doing at this point is evaluating or predicting. Be careful of getting into how you will respond, this will be session seven.
E-1	Case of the Crossover

Teaching Point	Rationale
	<p>Put E-1 on the screen and read the narrative to the students and use a pointer to identify vehicles and actions and then give them time to respond.</p> <p>The consensus on this case study will usually be:</p> <ol style="list-style-type: none"> 1. High conflict probability with "B" 2. Within two seconds 3. All of your lane 4. To help identify contributing factors, you can ask the following questions: <ol style="list-style-type: none"> a. What are the requirements for merging traffic? b. Are there timing and positioning problems? c. Would acceleration capability be a factor? d. Other questions or considerations? e. Will the conflict point be within the stopping zone? f. In such situations, what is the general rule for "A" to follow? For "B" to follow? 5. It is very important to watch actions of "B" to determine whether he wants to go in front or behind "A"
E-2	<p>Case of the Right Turn Surprise</p> <p>Put E-2 on the screen and read the narrative to the students and use the pointer to identify vehicles and actions and then give them time to respond. You will need to indicate that you are approximately so many seconds from the intersection, e.g. five seconds.</p> <p>The responses will usually be:</p> <ol style="list-style-type: none"> 1. High conflict probability with "C" 2. Within 2-4 or 5-12 3. Even though driver "C" should not need more than one-half of your lane, you might want to predict the worse and say all. 4. To help identify contributing factors, you can ask the following questions: <ol style="list-style-type: none"> a. What traffic laws and rules apply? b. What are the probable driver errors? c. Other questions or considerations? d. Will the conflict point be within your stopping zone? 5. It is very important to search actions of "C" and even "D" to help you in the decision process.
E-3	<p>Case of the Off-Road Recovery</p> <p>Put E-3 on the screen and read the narrative to the students and use a pointer to identify vehicles and actions and then give them time to respond. You will need to indicate that you are following car "C" so many seconds, e.g. three or four seconds or six to ten seconds from "C" and "B".</p> <p>The responses will usually be:</p> <ol style="list-style-type: none"> 1. High conflict probability with "B" 2. Conflict point dependent upon the distance you give them

Teaching Point	Rationale
	<ol style="list-style-type: none"> 3. An incorrect response by "B" will result in all of your lane being used 4. To help identify contributing factors, you can ask the following questions: <ol style="list-style-type: none"> a. What are the best procedures for the driver of car "B" to follow? b. What driver errors are likely? c. Does the condition of the shoulder affect the driver's response? d. What actions should you search for to determine whether or not driver "B" might close on your path?
E-4	<p>Ongoing Trucks on Freeway at Merge Situation</p> <p>Put E-4 on the screen and indicate that traffic is moving approximately 50 mph and your space cushion with the tan car in lane two is 3 seconds.</p> <p>The responses will usually be:</p> <ol style="list-style-type: none"> 1. High conflict probability with truck in lane 3 2. Conflict within 2 seconds 3. All of your lane being used 4. The following questions should be asked: <ol style="list-style-type: none"> a. Are you in the truck driver's blind spot? b. Why is the truck driver changing lanes? c. What will occur to the speed of the truck once it changes lanes and it approaches the slight upgrade?
E-5	<p>Ongoing Vehicles on Freeway Approaching a Highway Split</p> <p>Put E-5 on the screen and indicate that traffic is moving at 45 mph and you have a 6-second space cushion with the vehicle in front of you and you are going south toward York.</p> <p>The responses will usually be:</p> <ol style="list-style-type: none"> 1. High conflict probability with the car in lane 2 2. Conflict within 2 seconds 3. All of your lane will be used 4. The following questions should be asked: <ol style="list-style-type: none"> a. How many lanes of traffic are you currently in? b. At the split, how many lanes of traffic will there be available? c. What are the clues that the car in lane 2 is changing lanes to lane 3?
E-6	<p>Entering Vehicles onto the Freeway at Weave Lane Interchange</p> <p>Put E-6 on the screen and indicate that the traffic is moving at 55 mph and your following distance with the vehicle in lane 2 is 4 seconds. You can have the driver continuing straight or exiting at Highland Park.</p> <p>The responses will usually be:</p> <ol style="list-style-type: none"> 1. High conflict probability with both entering vehicles. 2. Within 2 to 4 seconds 3. All of your lane

Teaching Point	Rationale
	<p>4. The following questions should be asked:</p> <ul style="list-style-type: none"> a. What do you predict the second of the two entering vehicles will do? b. What driver errors do you identify? c. How do you know that the entering vehicles have to merge?
E-7	<p>Multiple-Lane Freeway Proceeding Straight at Exit Area Put E-7 on the screen and indicate that traffic is moving at 50 mph and you have an 8 second space cushion on the vehicle in front of you in lane 3. Also indicate that the van on the right had initially been static with brake lights activated. The responses will usually be:</p> <ul style="list-style-type: none"> 1. High conflict probability with the van from the right 2. Within 5 to 6 seconds 3. All of your lane 4. The following questions should be asked: <ul style="list-style-type: none"> a. What clues should you look for to predict that the van might come over into lane 3? b. What type of exit does there appear to be after the present exit?
E-8	<p>Ongoing Traffic on the Freeway Put E-8 on the screen and indicate that you are traveling at 65 mph and the first and second vehicle in lane 1 have just passed you. The responses will usually be:</p> <ul style="list-style-type: none"> 1. High conflict probability with the truck from lane 1 2. Within 2 seconds 3. All of your lane 4. Ask the following questions; <ul style="list-style-type: none"> a. What clues can you identify that makes you predict the truck will enter your lane? b. Why don't you think the first vehicle in lane 1 will immediately enter your lane? What type of high risk area are you approaching? c. Are you in the truck driver's blind spot What type of high risk area are you approaching? d. Are you in the truck driver's blind spot?
E-9	<p>Multiple-Lane Traffic In-Town Put E-9 on the screen and indicate that you are traveling at 25 mph and you have a 3-second following distance on the vehicle in lane 1. You are approaching a pedestrian crosswalk area near the UPS truck. The responses will usually be:</p> <ul style="list-style-type: none"> 1. High conflict probability with the truck in lane 2 2. Within 2 seconds 3. Expect half to all of your lane being used 4. Ask the following questions: <ul style="list-style-type: none"> a. Why do you expect the driver of the truck to enter your lane?

Teaching Point	Rationale
	<ul style="list-style-type: none"> b. What will happen to the speed of the truck as it enters your lane? c. Why are the brake lights of the vehicle in front of you being activated?
E-10	<p>Disabled Vehicle on the Shoulder</p> <p>Put E-10 on the screen and indicate that the speed of the traffic in lane 1 is 60 mph and you have a 3-second following distance on the vehicle in your lane.</p> <p>The responses will usually be:</p> <ul style="list-style-type: none"> 1. High conflict probability by the driver of the vehicle in lane 2 2. Within 2 seconds 3. Expect all of your space to be used, even though the driver of the vehicle does not need to use any of your lane 4. Ask the following questions: <ul style="list-style-type: none"> a. What is the clue that the driver of the vehicle in lane 2 has a short sight distance? b. How do you expect the driver in lane 2 to respond when he suddenly gets near the hazard markers? c. What type of area are you approaching that might cause the driver of the vehicle in lane 2 to be staying in lane 2 and going below the posted speed?
Summary	<p>After the last slide, emphasize that they have just demonstrated an evaluation or prediction process that should enable them to make lower risk decisions. The key point to remember is to identify all real and potential hazards as early as possible so that they can respond in a non-threatening manner and also reduce the risk of other users in proximity to them. They are now ready to move into the final session and this relates to Response to Traffic Situations.</p>

Objectives

- 1. The three parts of the projected path of travel
- 2. Measuring following distance with time
- 3. Measuring stopping distance with time
- 4. Measuring sight distance with time
- 5. Identifying probable errors of other users
- 6. Determining a high or low probability of conflict
- 7. Determining when a potential conflict can occur and how much of your space it might occupy

Projected Path of Travel

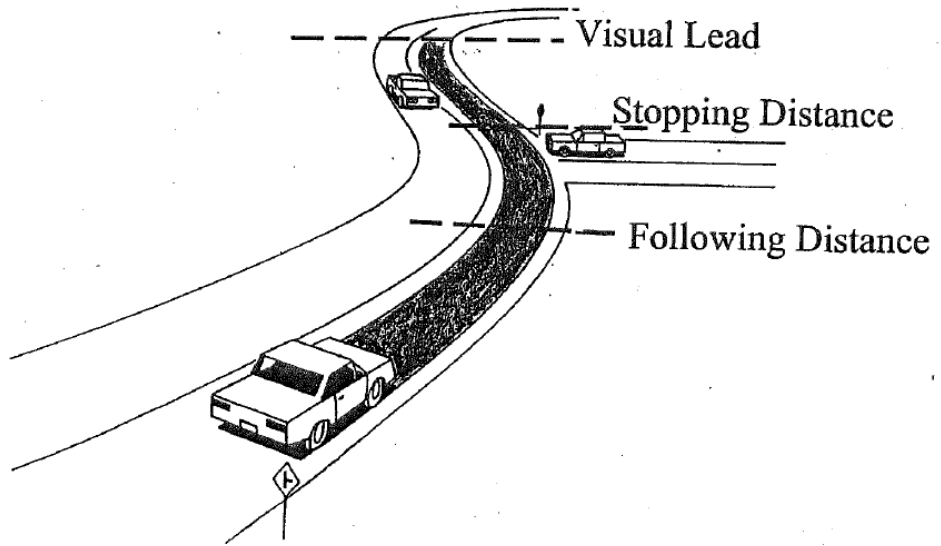

Identify Probable Errors: Failure to Observe Laws

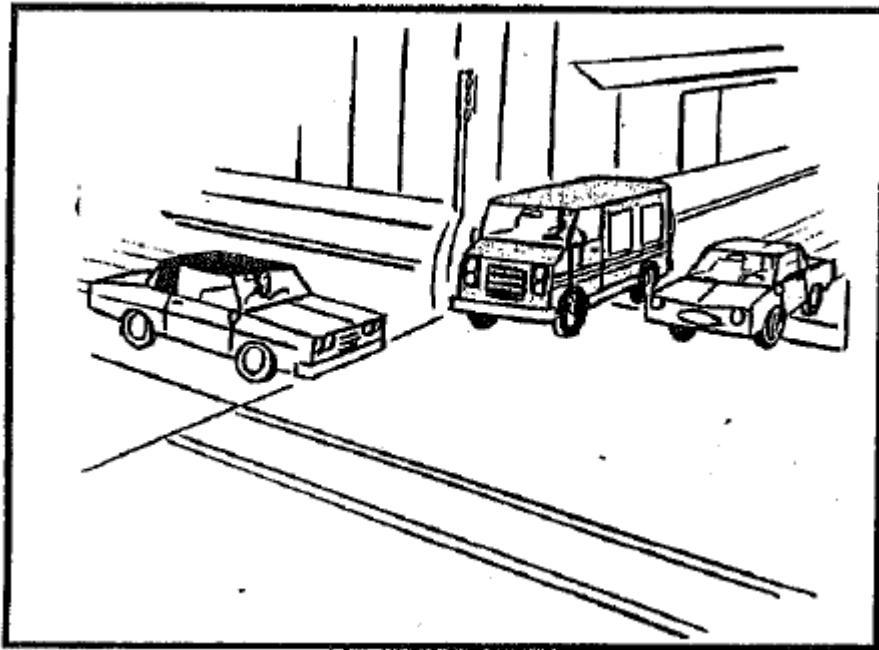

Fails to yield right-of-way

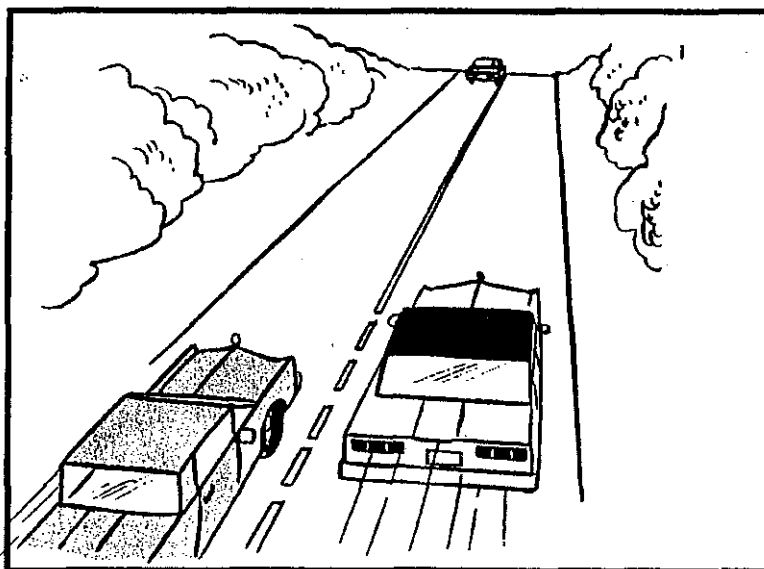

Fails to observe pavement markings

Identify Probable Errors: Improper Responses to Highway Conditions

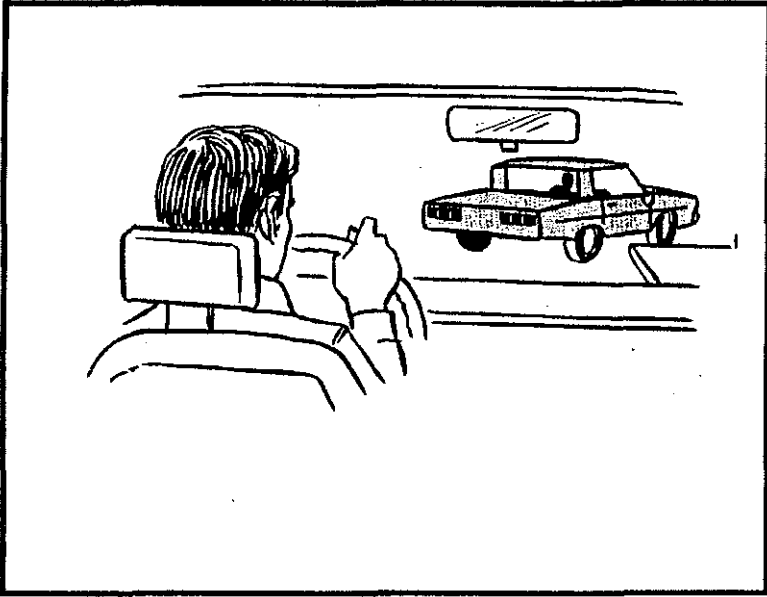

Sharp curbing

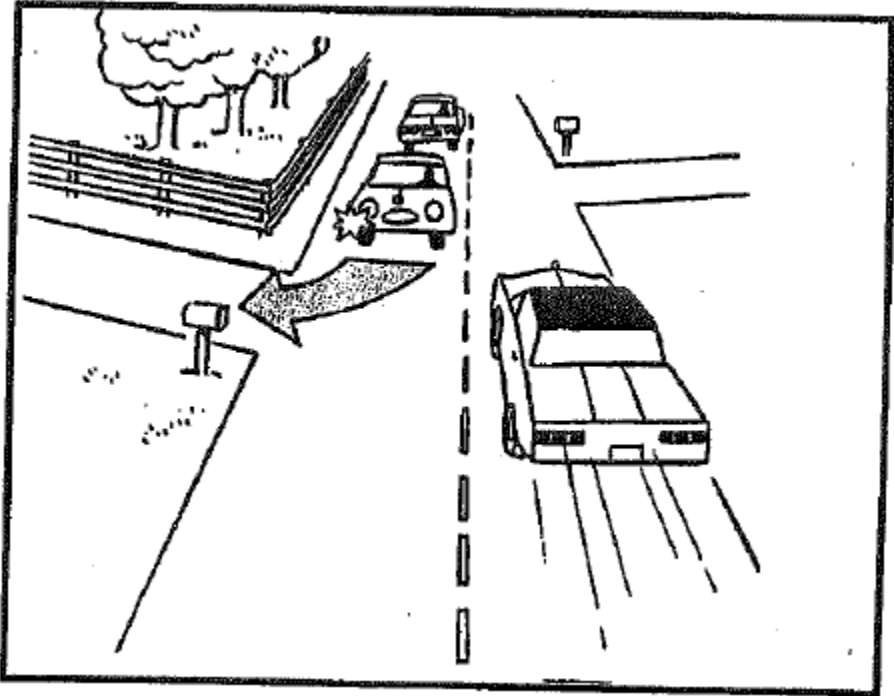

Narrow Side Road

Identify Probable Errors: Improper Responses to Other User Actions

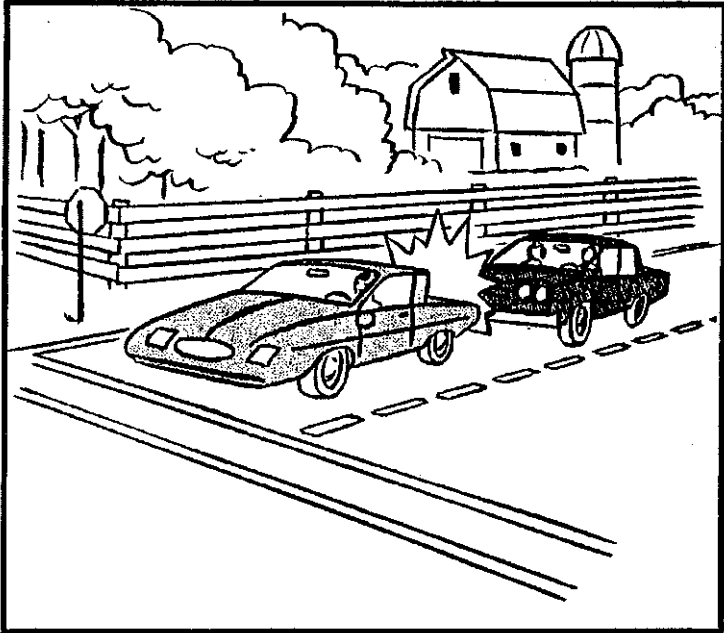

Follows too closely

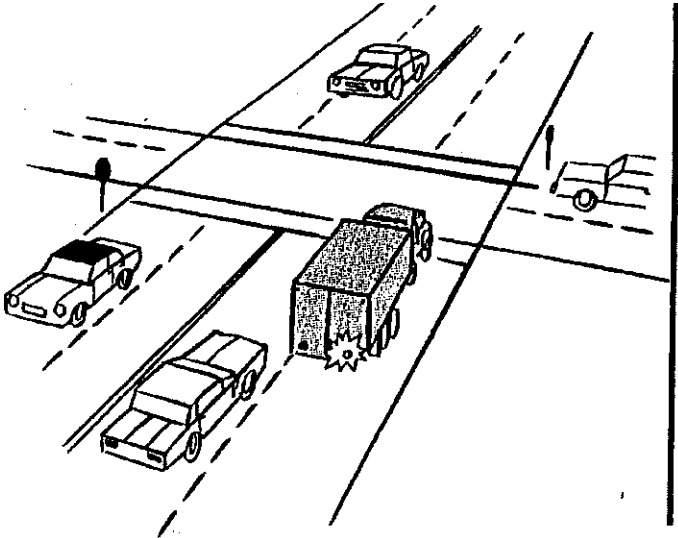

Drives in Blind Spot

Identify Probable Errors: Improper Vehicle Control Actions

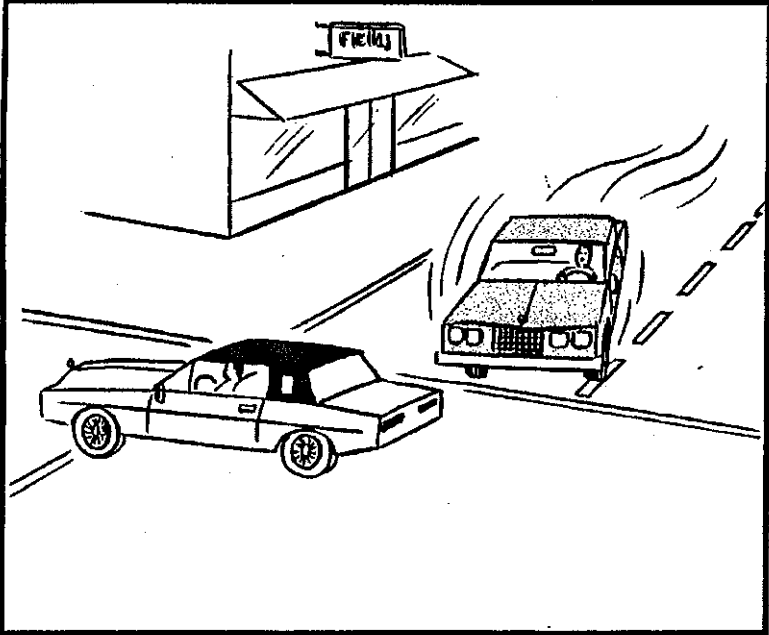

Lose control in skid

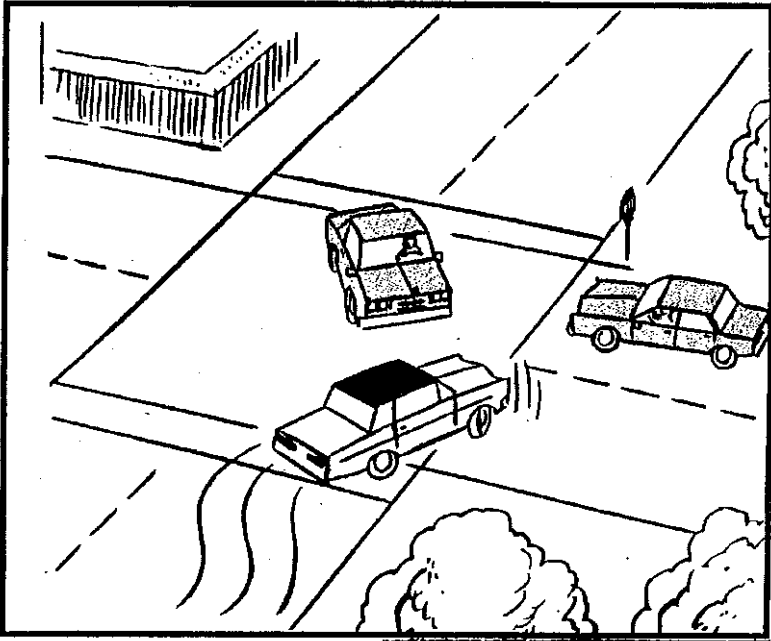

Swerves too quickly

Evaluate Conflict Probabilities of Other Users: Driver Actions are Very Limited

- Drivers can change direction
- Drivers can change speed
- Drivers can communicate

Focus on the action that could cause a closing

Evaluate for Conflict Probabilities: Identify Low Chance of Conflict

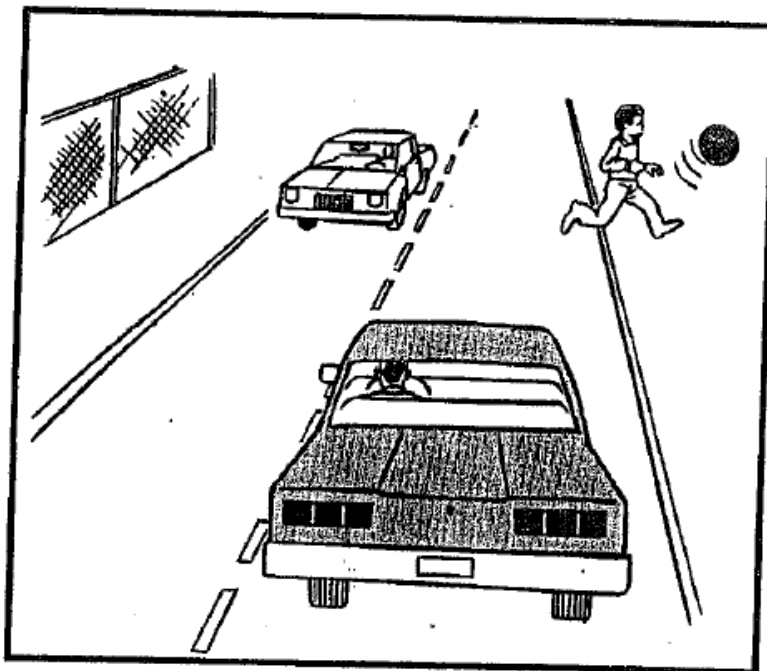

More evidence against a conflict

Evaluate for Conflict Probabilities: Identify High Chance of Conflict

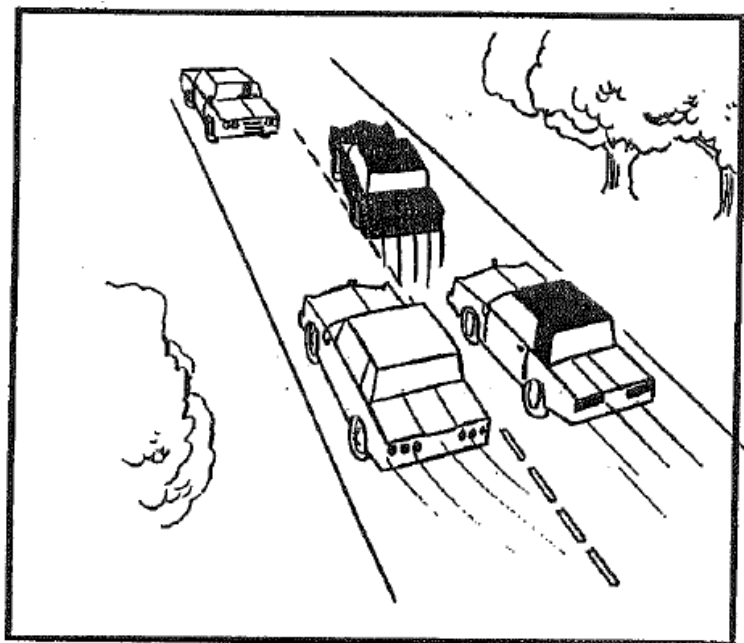

More evidence for a conflict

Identify Probable Point of Conflict

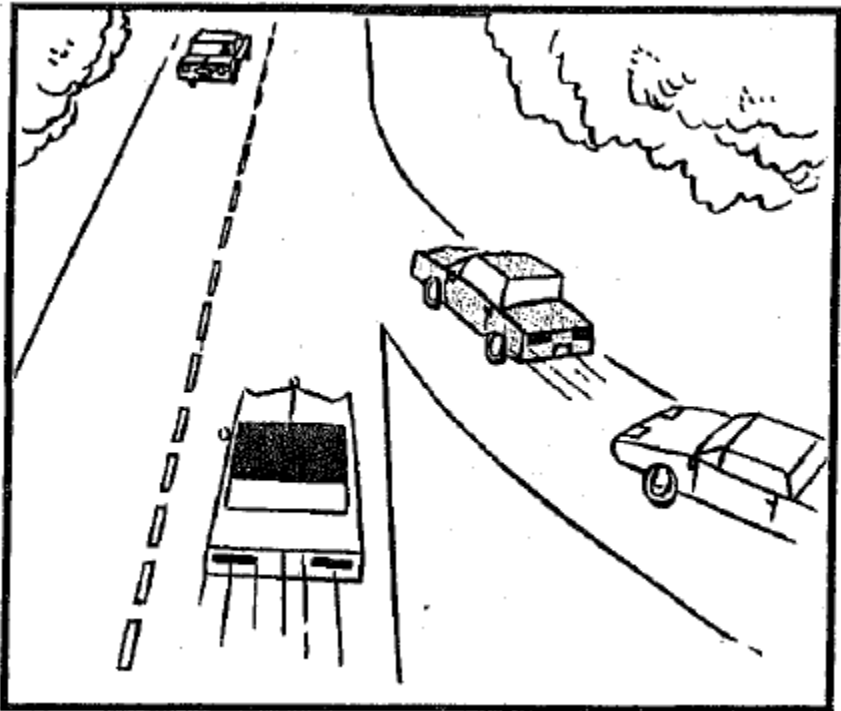

Judge speed of closing

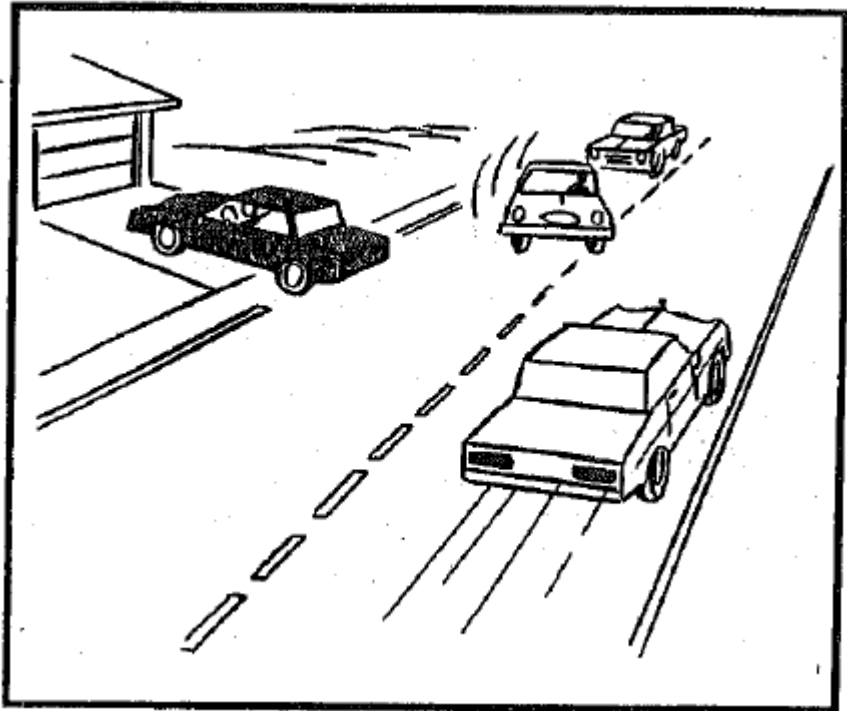

Judge amount of space needed

Case of the Crossover

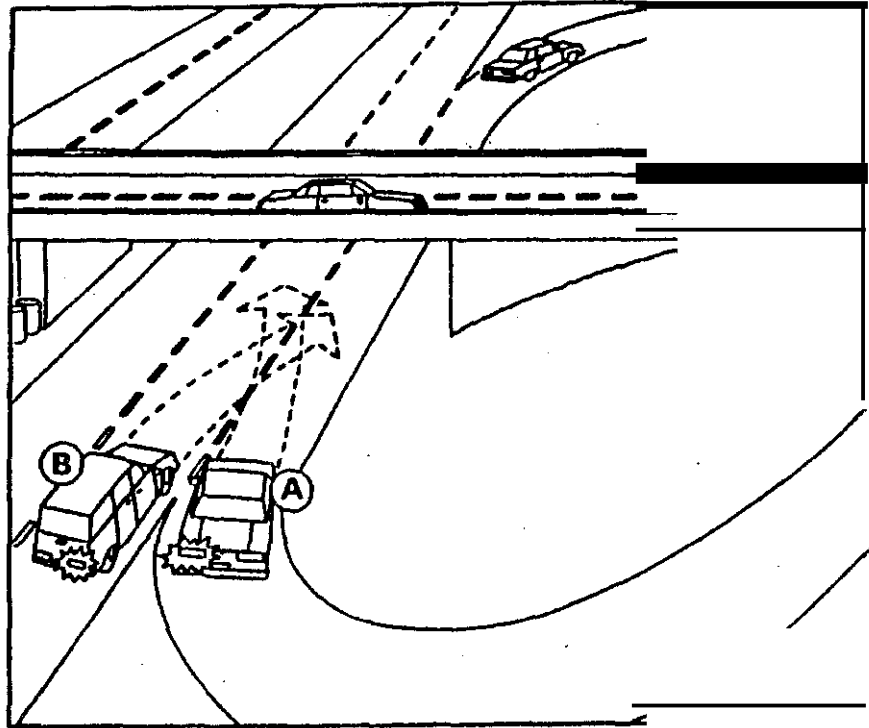

At a cloverleaf interchange, you are driving vehicle "A" getting ready to merge onto the freeway. Vehicle "B" is signaling and starting to slow down for an exit.

Case of the Right Turn Surprise

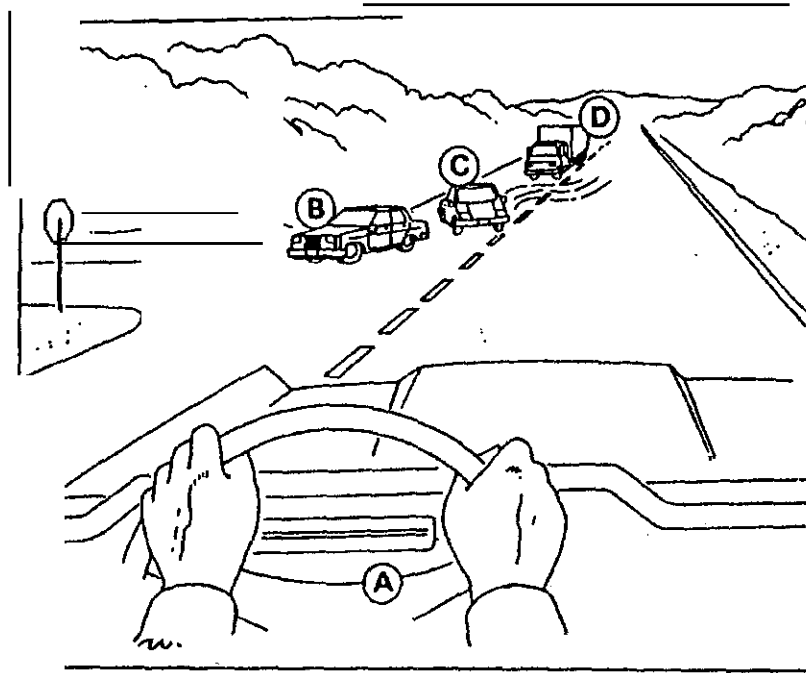

You are driving vehicle "A" about 55 mph on a two-lane highway with wide shoulders. The oncoming car "C" had plenty of time to pass car "D" and pull in behind car "B". However, car "B" slows down suddenly, and without signaling, starts to make a right turn. Car "C" starts swerving toward your lane.

Case of the Off-Road Recovery

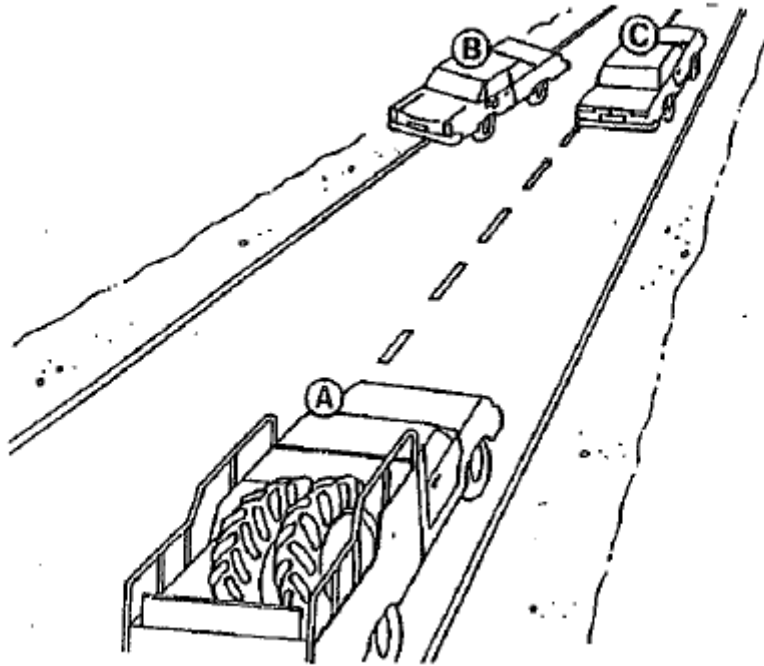

You are driving vehicle "A" about 50 mph on a two-lane rural highway. Car "B" has just slipped off the edge of the pavement with two wheels on the shoulder. There is at least a two-inch drop from the pavement to the shoulders.

Session Seven: Responding to Problem Situations

Time:

Minimum of two class periods.

Purpose:

Processing information and making decisions is the primary task associated with safe and efficient driving. Knowing how and what to identify is the first step in this process and predicting or evaluating what is identified is the second step. The third step is the ability to make wise and timely decisions, and this is dependent upon the first two steps. Conditions and events affect a driver's speed selection, position selection and communication selection; and the ability to make and carry out these decisions in sufficient time is the basis for safe and efficient vehicle operation. The driver education text should serve as a resource for this session, and the most appropriate parts would include:

1. Natural Laws and Car Control
2. Negotiating Intersections
3. Sharing the Roadway
4. Driving in Different Environments

Materials/Equipment:

- Perceptual Driving Program, Session Seven
- Driver Education Text
- Selective Work Sheets
- Overhead Projector or Power Point
- Slide Projector Screen Chalkboard
- Computer/Presentation Software
- CD Rom- Module III, Perception and Driving Strategies for Different Environments
- Computer with CD capability and LCD Projector

Session Objectives:

1. Students will demonstrate their ability to manage the space around their vehicle;
2. Students will demonstrate their ability to time their driving actions to reduce the risk associated with other highway users;
3. Students will identify the various factors that usually require a speed adjustment;
4. Students will demonstrate how to manage real and/or potential hazards by adjusting their path of travel;
5. Students will identify the various ways that drivers can communicate to one another; and
6. Students will identify and evaluate selective case studies and select responses that will demonstrate the decision-making process.

Session Outline:

1. Kinds of Decisions
2. Nature of Decision-Making
 - a. What to Do?
 - b. Where and When
 - c. How Much?
3. General Guidelines
 - a. Maintain Adequate Space Margins
 - b. Time Your Driving Actions
 - c. Choose the Best Speed for Conditions
 - d. Choose the Best Path of Travel
 - e. Communicate All Changes
4. Remarks About Mental Habits
5. Case Studies for Application
 - a. Diagrams
 - b. Traffic Scenes

Guidelines for Conducting Session Seven

Teaching Point	Rationale
Show R-A Master. Show each objective as it is introduced.	The main job of a driver is to process information and make decisions. You have learned some ways to identify and evaluate highway conditions and traffic events. Now, you must decide what to do about these conditions and events. The ability to make wise and timely decisions in traffic is the real test of a safe driver. That is the goal of this session. The primary objectives of this session are: Use the objectives from R-A and those listed on first page. In this session, you will be given five general guidelines for choosing proper responses to traffic situations. Then you will be given case studies to solve
Show R-B Master.	Kinds of Decisions The driving decisions you must make are many and varied; some are continuous. On the screen is a list of the kinds of driving decisions you will encounter. Can you add to this list? Remember some decisions are made in a relaxed and unchallenging manner, while other decisions are ongoing and require immediate response. Point out that "What Route to Follow" and "What Time to Start" are usually relaxed decisions, while all the others occur continuously.
Show R-C Master.	Nature of Decision-Making
Show each point as it is discussed.	Deciding is the act of making a choice between things or ways of doing things. In driving, making choices is a continuous process which is influenced by all the changes taking place around your vehicle. To make wise choices, you will need to follow the traffic laws and certain basic guidelines that will be provided.

Teaching Point	Rationale
But how to carry out the choice can be quite varied.	<ul style="list-style-type: none"> • The first step in making decisions is to identify the choices available. Such choices are usually limited to making changes in direction, making changes in speed and communicating. • Changing direction may involve making one-fourth, one-half or one full turn of the steering wheel. Steering may be done gradually or quickly which could result in a swerving action. • Changes in speed can be done in a variety of ways involving the use of the gas pedal, the brakes, the gearshift or a combination of these. • There are a variety of ways to communicate as will be indicated later in the session.
Other comparisons.	<p>Compare for Consequences</p> <ul style="list-style-type: none"> • For each choice or alternative course of action, there can be measurable consequences. To make comparisons, use the evidence you gathered to judge for and against the conflict probabilities. • Compare colliding with a pedestrian or bicyclist to colliding with another vehicle. Compare colliding with an object head-on or hitting an object with a glancing blow. Compare hitting a solid object to hitting one that is flexible. <p>Choose the Best Response</p> <ul style="list-style-type: none"> • The best response is the one that allows you to achieve the most favorable position in the traffic stream. It provides for efficient as well as safe travel along a path. • The best choice is usually one with the least chance of closing on some object or having another user close on your stopping zone path of travel. • If a collision cannot be avoided, then the best choice would be the one with the least consequences. <p>Apply a Plan of Action</p> <ul style="list-style-type: none"> • To be able to make the best choices and carry them out in time, you must be prepared. Mental actions do take time, even if only a fraction of a second. • Additional time is required to make multiple and complex choices. Unfamiliar situations also necessitate additional time to make safe choices. • Being prepared means having a plan of action. A plan of action saves time by providing you with a proper response in advance of most situations. • Using a plan of action in making choices includes applying rules or guidelines. As you do so, certain responses will become automatic. Then, as you gain experience, you should be able to cope with more and more complex situations.
Show R-D Master.	<ul style="list-style-type: none"> • Your plan of action should consist of at least these five general guidelines:

Teaching Point	Rationale
Show each Guide as it is introduced.	<ol style="list-style-type: none"> 1. Maintain adequate space margins; 2. Time your driving actions; 3. Choose best speed for conditions; 4. Choose the best path of travel; and 5. Communicate all changes.
Show R-E Master.	<p>Maintain Adequate Space Margins</p> <p>This is your first guideline in having a plan of action. What is a space margin? It is the amount of hazard-free space a driver has around the vehicle at any given time. Think of it as an imaginary protective space that extends from all sides of your vehicle- ahead of you, behind you, above you, and to your right and left. It is made up of the distances between your vehicle and other users and between your vehicle and other objects.</p>
Ask why this is so	<p>Allow at Least Two or Four Seconds Ahead</p> <ul style="list-style-type: none"> • Under normal conditions, the two-seconds following distance and the four-seconds stopping distance provide a minimum distance ahead. • If you are behind a vehicle such as a motorcycle or large truck, it is best that you increase your following distance. • Of course, reduced traction always calls for an increase in stopping and following distance.
Ask why this is so.	<p>Allow at Least Two Seconds Distance to the Rear</p> <ul style="list-style-type: none"> • The distance to the rear is difficult to control. • If vehicles are following too closely (tailgating), allow more distance ahead. • If a large truck is following too closely allow more distance ahead. <p>Allow One Vehicle Width on at Least One Side</p> <ul style="list-style-type: none"> • The distances to the sides should be enough to provide for errors in judgment and to give you an "escape path." This would be a four to six second alternate path of travel or "escape path." • Always have at least one vehicle width of space on one side of your vehicle. If this is not possible, your only "escape path" or alternate path of travel is in front. Therefore, you will need a minimum of a four to six second space cushion.
Show R-F Master.	<p>Time Your Driving Actions</p> <p>This is your second guideline. You can't control road conditions or the movements of other traffic; but you can control where you meet moving vehicles and pedestrians. This is done by timing your actions and the movement of your vehicle.</p> <p>Illustration on Screen</p> <ul style="list-style-type: none"> • In the situation shown, you should adjust your speed so that you will not be opposite the bike rider and the car with a flat tire when meeting the oncoming vehicle. Why?

Teaching Point	Rationale
	<ul style="list-style-type: none"> • This should have been identified as an area of less space to sides. Serious consequences could arise if there were even a slight error in judgment or if the bike rider happened to veer left to miss a pot hole. • In this situation, we can't control what the bicyclist does, the driver with the disabled vehicle or the driver of the oncoming vehicle. The only driver that we can control is you and you must control this situation by timing your actions.
Solicit other examples from class.	<p>Other Examples of Timing Situations</p> <ul style="list-style-type: none"> • Try not to meet other large vehicles at areas of less space, and especially in combination with high cross winds or with less traction. • Choose the best time at which you will change lanes or pass another vehicle or go by areas where small children are playing • Time such actions as checking mirrors, signaling and downshifting so that they do not interfere with your attending to closing hazards or with critical control actions. • Actions that are unrelated to driving tasks (for example, scenic viewing or adjusting the heater or radio) can be distracting. Therefore, postpone such activities whenever roadway or traffic conditions demand your full attention.
Show R-G Master.	<p>Choose Best Speed for Conditions</p> <p>This is your third guideline. Deciding how fast to travel requires good judgment. This is because speed is such a relative thing. If speed is too fast for conditions, you will not be able to stop or swerve in time to avoid a collision. Speed too fast for conditions also makes it difficult for other users to predict what you will be doing.</p> <p>The high-speed capabilities of motor vehicles should be considered only as reserve power for an emergency. Fast driving on public highways is not the mark of an expert driver. The expert driver is one who makes the proper changes in speed for the conditions present.</p> <p>What is a safe speed? Our traffic laws give us the specific and general guidelines. Here are additional ones.</p>
Show R-H Master.	Adjust Speed for Highway Conditions
Uncover each highway condition as it is discussed.	First, it must be assumed that a driver has selected a safe speed for the given set of conditions. Changes in the highway conditions of visibility, space and traction are the factors that determine whether a speed adjustment” is necessary.
Examples.	<ul style="list-style-type: none"> • Changes in sight distance ahead. The distance you can see ahead must not be less than the distance needed to stop. You must adjust speed for hills, curves, darkness, sun glare, rain or fog.

Teaching Point	Rationale
	<ul style="list-style-type: none"> • Changes in surface conditions. Crowned or banked roads offer less stability than a flat road. What is on the pavement surface can cause a change in the amount of traction. For example, wet pavements can double your stopping distance. • Changes in space to sides. The closer you must drive to other vehicles or objects, the smaller the error in judgment is needed to cause a problem. The faster you go, then, the less chance you have for making a correction. When you come to an area of less space and there is no swerving distance to the sides, then a speed adjustment is your only choice. • Changes in view to sides. When highway conditions reduce your view to sides, there is less chance of judging what drivers on the side roads will do. Also remember, the drivers of intersecting vehicles can't see you either.
Show R-I Master.	Adjust Speed for Traffic Conditions
Show each traffic condition as it is discussed.	<p>The types, the number, the location and the speed of other traffic are factors that you must consider when choosing a reasonable and proper speed.</p> <ul style="list-style-type: none"> • Adjust speed to flow of traffic or the common speed. The larger the difference in speed of moving vehicles, the greater chance there is for conflicts and errors in judgment. So, as a general rule, drive at the common speed of traffic. Blending with the flow of traffic is not only safer, but it will save fuel. • Adjust speed for types and amount of traffic. Is traffic heavy? Are there school buses, trucks, or two-wheelers present? Will you be dealing with pedestrians? During late afternoon hours, drivers may be tired or in a hurry, and children could be getting out of school. Late at night, drivers may be sleepy or under the influence of alcohol.
Emphasize that this is especially true at interchanges.	<ul style="list-style-type: none"> • Adjust speed for location of other traffic. You will need to adjust speed to avoid driving in the blind spot of another driver, and do not let another vehicle be in your blind spot. Of course, you must adjust speed to maintain a proper following distance from the vehicle ahead.
Show R-J Master.	Adjust Speed for Time Needed
Show each situation as it is discussed.	Two of the most important requirements for driving are space and time, both of which are related to speed. You must have time to observe events, decide what to do and then take proper actions.
Relate this to the second guideline, Time Your Driving Actions.	<ul style="list-style-type: none"> • Time is needed to observe and process information. The more traffic controls and events taking place around your vehicle, the more time you will need for perceiving and deciding what to do. • Time is needed for avoiding traffic hazards. The number and nature of the traffic hazards will determine whether or not a speed adjustment is required. When a hazard cannot

Teaching Point	Rationale
	<p>be minimized by distance to the sides, then a proper speed adjustment should be made.</p> <ul style="list-style-type: none"> • Time is needed to make maneuvers. Time is required for braking and steering actions -usually at least one- half second. Time is also required for accelerating into or across gaps in traffic. Maneuvers can take from four to ten seconds to complete.
Show R-K Master.	<p>Choose the Best Path of Travel</p> <p>This is the fourth guideline for a Plan of Action. In addition to these guidelines, there are certain traffic laws that apply. Most states require that slower traffic keep to the right. The left lane or lane one is usually considered the passing lane. Of course, turns should be made from the farthest lane to the left or right.</p>
Have class give examples of selecting a lane.	<p>Best Lane</p> <p>The best lane is the one that offers the safest space margins to the sides and a reasonable flow of traffic. Such a lane should provide the best view ahead, "the best traction and the least chance of conflict. The best lane should also be one as it relates to your selected maneuver.</p>
Have class give examples of when they would adjust their position within the lane.	<p>Best Position Within the Lane</p> <p>Once you have selected the best lane for travel, you will need to consider the best position within that lane. Visibility ahead and distances from hazards to the sides are factors to consider.</p>
Ask class to give examples of when they would use a half right or left. Have class give examples of when this is done.	<p>Five Basic Positions</p> <ul style="list-style-type: none"> • As illustrated on the screen, there are five basic positions that you should picture in your mind. The first is in the center of the lane. This can also be referred to as "zero" position. • A move of one-half vehicle width to the left or right of center will place you next to a lane line. You are straddling the original right or left tire track from center position or "zero" position. • A move of one full vehicle width to the left or right of center will usually put you straddling a lane line. You are now placing the right tire in the original left tire track from "zero" position or vice versa. • Positions any farther to the right or left are considered lane changes.
Show R-L Master.	<p>Communicate All Changes</p>
Show each form of communication as it is discussed.	<p>Whenever you plan a change in direction or speed, other users should be told about it in advance. In fact, there are many times when just your presence should be communicated.</p> <p>Nature of Communication</p> <ul style="list-style-type: none"> • Communication is an exchange of information with other people. At times it can be very subtle.

Teaching Point	Rationale
	<ul style="list-style-type: none"> In driving, communication means much more than just signaling. It means receiving information as well as giving it. For example, you need to watch the other user's signals and actions to find out if your signals are being received and heeded.
Have class give examples of using the various electric signals.	Methods for Communication <ul style="list-style-type: none"> Use electric or hand signals. You have a choice of turn signals, brake lights, back-up lights and four-way flashers.
Ask class to give examples of good horn use and bad horn use.	<ul style="list-style-type: none"> Use the horn. Choose a gentle tapping, a sharp blast or a steady blast. Selectively use the horn to get the other user's attention if you think he/she does not see you. Use body actions and gestures. You can use hands, make head checks, nod head up and down, smile or look puzzled.
Have class give examples of when you might use the headlamps.	<ul style="list-style-type: none"> Use your headlamps. You can flash headlights off and on or switch them from low to high beam and back again. Use your vehicle's position. Being in a turn lane or drifting toward the line could indicate our desire to make a lane change, a desire to make a turn, or to allow a driver behind you to see better as to why you might be slowing.

Remarks about Mental Skills

We hope some of the ideas and guidelines for improving your perceptual driving skills have been helpful to you. Still, you may be thinking, "Who in the world has time to do all that while driving?" You're right, it is a lot to ask. However, let's not forget the power of the human brain.

The human brain is like a giant computer. With practice, it will be able to process some of these things within a fraction of a second. But, like a computer, the brain is of little value if it hasn't been fed the right kind of information. It will also need some rules or guidelines for using this information it is storing. This is what we have been trying to present to you- both the right kind of information and guidelines for applying it.

At one time or another, you have probably solved a puzzle. What happens the second time you try to solve it? It seems much easier, and takes only a fraction of the time it did the first time. There are two reasons for this: you can identify the clues more quickly, and you know what to expect. You no longer have to rely on trial and error. Then, too, similar puzzles become easier to work, even the first try.

This same puzzle-solving principle also applies to coping with traffic situations. As you continue to practice your improved mental skills in a vehicle as a driver or as a passenger, you will be able to handle the common situations almost automatically. This will free the higher centers of your brain to deal properly with the unusual or more complex traffic situations. As these mental skills continue to improve, the chances of your getting trapped into a collision course will become less and less.

Another interesting thing will begin to happen, too. Your mind will bring together all you have learned into one whole process. Your eye habits, your identification and evaluation abilities, and the information you have stored will combine into one single set of mental skills. As you scan the traffic scene ahead, you will, with quickness and accuracy, both perceive any conflicts and decide what to do. This will increase your confidence, and someday, as you look back on your driving experiences, you will take pride in your ability to drive without ever having a preventable collision.

Case Studies for Application

Teaching Point	Rationale
<p>Hand out Answer Sheets for Case Study Responses. Make a copy to put on screen for discussion.</p>	<p>To help you apply the five general guidelines for having a Plan of Action, case studies will be shown on the screen. Once again, there will be diagrams of traffic situations and actual traffic scenes. There are a total of ten case studies, three diagrams and seven traffic scenes. The picture will be left on the screen as you complete the answer sheet for the respective case study. You should respond in the following manner.</p>
<p>Review the descriptions of position, speed and communication.</p>	<ol style="list-style-type: none"> 1. Determine the best position to take with your vehicle. 2. Determine the best speed adjustment with your vehicle. 3. Determine the best communication(s) to use. <p>Be able to identify why you are taking the actions you select when we discuss the various responses.</p> <p>We will try to get a general consensus as to the response with the lowest risk. Remember, we are interested in the decision-making process and how well you identify all of the real and/or potential hazards and how you manage these hazards. This could also be referred to as taking calculated risks versus haphazard risks. You should be able to demonstrate being a proactive driver versus a reactive driver.</p> <p>Teaching Points</p> <ul style="list-style-type: none"> • The first three case studies are diagrams and can be used as a transparency or power point. The remaining seven are traffic scenes and will need to be shown with a slide projector. • When using the traffic scenes, you will need to agree to certain assumptions to help set the stage for responses that the class will consider. • You can use all ten case studies or you can reduce the number by using the first three diagrams and then the necessary number of traffic scenes that demonstrate the decision-making process. • Once again, the key concept is that the students demonstrate the decision-making process and that they can justify their responses by showing you how they gathered all of the available information and selected the response that had reduced the risk of the respective case

Teaching Point	Rationale
	<p>studies. There is no Right or Wrong answer. What you are looking for is a decision-making process and why they feel it is the best response.</p> <ul style="list-style-type: none"> It is the teacher's job to help the students identify and analyze all of the available clues when they are not pointed out by the students.
R-1	<p>Case of the Narrow Median</p> <p>Put R-1 on the screen and read the narrative to the students and use a pointer to identify vehicles and actions and then give them time to respond.</p> <p>The students will usually identify one of the three decisions:</p> <ol style="list-style-type: none"> Reduce speed and allow "B" to pass, make a lane change to the right, and communicate with brake lights first and then right turn signal. Maintain or slight increase in speed, make the lane change to the right, and communicate with the right turn signal. The slight increase gives a greater space cushion for "B". Reduce the speed and stop if needed until "C" clears and then continue straight. <p>Questions for discussion:</p> <ol style="list-style-type: none"> With a narrow median, what is expected of "C"? Is vehicle "B" maintaining speed so that the gap remains the same? Will the car stopped at the right-side street be a problem? Will the oncoming car be a problem? If I select decision number 2, how do I reduce the risk to "B" and the vehicle stopped at the right and even the oncoming vehicle.
R-2	<p>Case of the Merge Conflict</p> <p>Put R-2 on the screen and read the narrative to the students and use a pointer to identify vehicles and actions and then give them time to respond.</p> <p>A controlled risk response could include:</p> <ol style="list-style-type: none"> Speed reduction and the difference between a gradual and a controlled hard brake would be determined by the space between you and "B" and also what is following you and their space. A half vehicle to the left opens some space ahead and it also allows drivers behind to see why you are slowing and also what is in lane two if they decide to pass you on the right. Brake lights will serve as a means of communication and so will your lane position. <p>Questions for Discussion:</p>

Teaching Point	Rationale
	<ol style="list-style-type: none"> 1. Does the interchange have anything to do with the tanker truck needing to come over immediately? 2. What are some clues that the tanker truck is going to merge immediately? 3. Does the driver of car B exhibit any deficiencies in his/her visual skill? 4. What type of highway condition are you approaching that will affect your speed selection?
R-3	<p>Case of the Hillcrest Hazard</p> <p>Put R-3 on the screen and read the narrative to the students and use the pointer to identify vehicles and their actions and then give them time to respond.</p> <p>A controlled risk response could include:</p> <ol style="list-style-type: none"> 1. Do a half vehicle to the right and this will give you more space between the bicyclist. 2. Do a quick increase in speed to get away from the limited space area. This might be difficult to comprehend because most drivers will immediately reduce speed. What supports a quick increase is the experienced factor and position of the bicyclist and it tells you that there are probably no vehicles directly behind the bicyclist. The other factor that could determine speed selection is the distance you are from the bicyclist and the crest of the hill. 3. If there is no eye contact with the bicyclist then a quick horn tap to appraise him/her of your location.
R-4	<p>Bicyclists on Open Highway</p> <p>Put R-4 on the screen and indicate that the posted speed is 55 mph. The responses will usually be:</p> <ol style="list-style-type: none"> 1. Move a half right. The oncoming vehicle has already moved a half left. The half right also gives a better view if people are following. 2. Speed selection will depend on which vehicle is closest to the bicyclist. If you are the closest, then a quick increase would be in order and it appears that the bicyclists are aware of us and the oncoming vehicle. If a speed decrease is in order, this will give us better control if we need to partially use some of the shoulder. We can't expect the bicyclists to use the shoulder because of traction problems and they could lose control. 3. If we are going to increase speed and pass the bicyclist before the oncoming vehicle, then flashing our headlights will make the driver aware of our actions. If slowing down, then brake lights are needed to tell drivers behind. Your vehicle position also helps in communicating.
R-5	Stationary Bicyclist

Teaching Point	Rationale
	<p>Put R-5 on the screen and indicate that the posted speed is 45 mph and the bicyclist is standing by the bicycle waiting to cross the roadway and is looking at us. The responses will usually be:</p> <ol style="list-style-type: none"> 1. Reduce speed and move a half left. 2. Communicate with brake lights and a half position to the left and observe the oncoming vehicle to be certain that the driver does not start to drift toward the center line. Flash headlights if this starts to occur. You do not need to communicate with the bicyclist, because eye contact has already occurred.
R-6	<p>Bicyclist on Urban Street</p> <p>Put R-6 on the screen and indicate that the posted speed is 25 mph, and you are approximately five seconds from the four-way intersection.</p> <p>The responses will usually be:</p> <ol style="list-style-type: none"> 1. Move a half left and crowd center line and oncoming vehicles. The oncoming vehicles will have more space to their right as they approach the intersection. 2. Reduce speed and prepare to pass the bicyclist after the intersection. Why is it best to time the pass after the intersection which is a limited view to the left and right? 3. The bicyclist does not appear to be a low-risk rider, and we should selectively use the horn to communicate our intentions if he does not acknowledge us.
R-7	<p>Turning Truck</p> <p>Put R-7 on the screen and indicate that the posted speed is 35mph.</p> <p>The responses will usually be:</p> <ol style="list-style-type: none"> 1. Reduce speed and the degree will depend upon the closing vehicle and the available traction. 2. Position should be a minimum of a half right and possibly one right. 3. Use brake lights to communicate your intentions. 4. A good question to ask the students is: What is the only zone that is open?
R-8	<p>Exiting at a Weave Lane Interchange</p> <p>Put R-8 on the screen and indicate that we are approximately four seconds from the exit lane and we plan on exiting.</p> <p>The responses will usually be:</p> <ol style="list-style-type: none"> 1. Reduce speed and position a half right and communicate with the right turn signal and brake lights. 2. Attempt to communicate with the following drivers by showing intentions with speed reduction, lane position, and

Teaching Point	Rationale
	<p>turn signal. Attempt to communicate with entering vehicles to get them to go in front of you by reducing your speed, moving a half right and the right turn signal. I would be careful about using headlights if there are vehicles behind me and to my left, because I cannot control their actions. The entering driver's speed will tell me if they are going in front of me or behind me.</p> <ol style="list-style-type: none"> 3. What is the posted speed? 4. How much of a deceleration lane and acceleration lane is available?
R-9	<p>Parked Cars on the Shoulder</p> <p>Put R-9 on the screen and indicate that the posted speed is 35 mph and you have a two-second following distance on the vehicle in front of you.</p> <p>The usual responses are:</p> <ol style="list-style-type: none"> 1. Reduce speed and move a half left. 2. Use brake lights to communicate behind and position a half left to let drivers from behind see the potential hazard. 3. Make certain that the oncoming vehicle does not start to crowd the center line. 4. Use the horn to alert the driver in the parked car if he/she does not acknowledge your position. 5. A good question to ask students is: What is the only zone that is open?
R-10	<p>Rural Railroad Crossing</p> <p>Put R-10 on the screen and indicate that the posted speed in this area is 45 mph.</p> <p>The usual responses are:</p> <ol style="list-style-type: none"> 1. Reduce speed and move a half right. 2. Use brake lights if a vehicle is following. 3. Search the railroad crossing. 4. Identify the second warning sign showing limited space. 5. Shoulders provide limited space and reduced traction.

Summary

- Your job as a driver is to attempt to identify all real and/or potential hazards in a sufficient amount of time so that you can reduce their risks. You reduce risks by adjusting speed and/or position, and then, communicating your intentions to all who are involved. If you apply good searching skills and identify and evaluate all highway events that relate to your projected path of travel, then you understand the whole process.
- This program that you just completed provides you with a good solid foundation to continue to build and develop your perceptual skills. The in-car Lesson plans are planned using the various visual skills that you learned in this program. You will have the

chance to apply and practice the various skills and this should give you a greater appreciation of their value. If you continuously practice the various skills, you can possibly enjoy a lifetime of collision-free driving.

Objectives

1. Managing the space around one's vehicle
2. Timing driver actions
3. Identifying factors that require a speed adjustment
4. Selecting a safe path of travel
5. Communicating one's intentions to other highway users
6. Demonstrating the decision-making process

Kinds of Decisions

What

- Route to follow
- Path to pick
- Maneuver to make
- Communication to use
- Time to start
- Speed to choose
- Controls to use

When and Where to

- Meet other traffic
- Perform maneuvers
- Change direction
- Yield
- Signal
- Change speed

How Much To

- Accelerate
- Decelerate
- Steer
- Brake
- Signal

Nature of Decision-Making

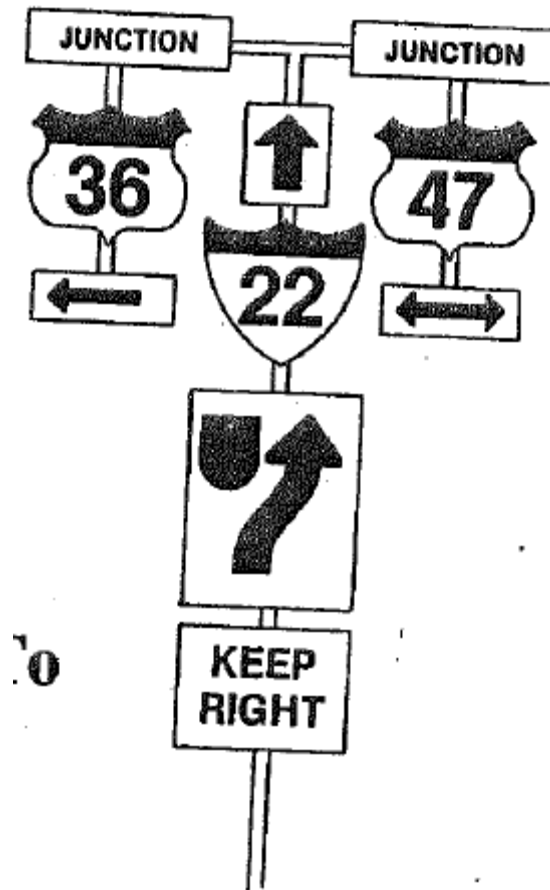

- Identify the Choices Available
- Compare for Consequences
- Choose the Best Response
- Apply a Plan of Action

Plan of Action

1. Maintain Adequate Space Margins
2. Time Your Driving Actions
3. Choose Best Speed for Conditions
4. Choose the Best Path of Travel
5. Communicate all Changes

Adjust Speed for Highway Conditions

- Changes in sight distance ahead
- Changes in surface conditions
- Change in space to sides
- Changes in view to sides

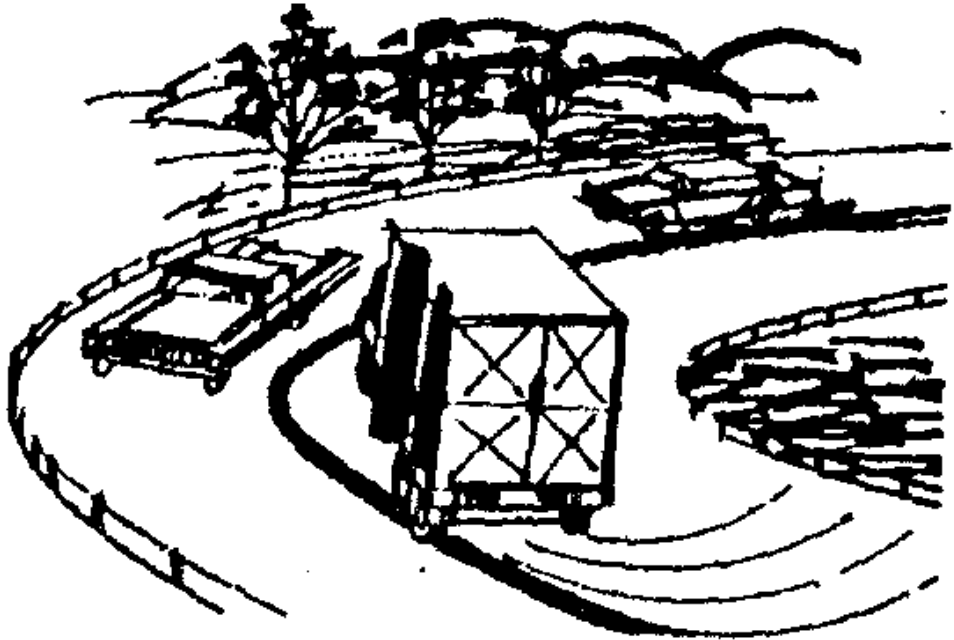

Adjust Speed for Traffic Conditions

1. Flow of traffic or common speed
2. Types and amount of traffic
3. Location of other traffic

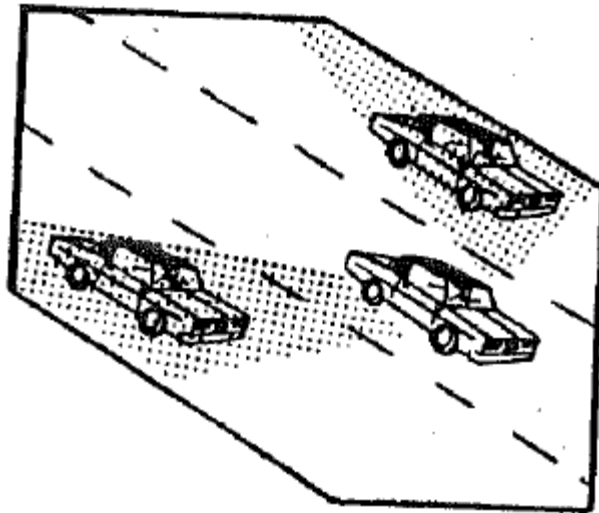

Adjust Speed for Time Needed

- Time to observe and process information
- Time to avoid traffic hazards
- Time to make maneuvers

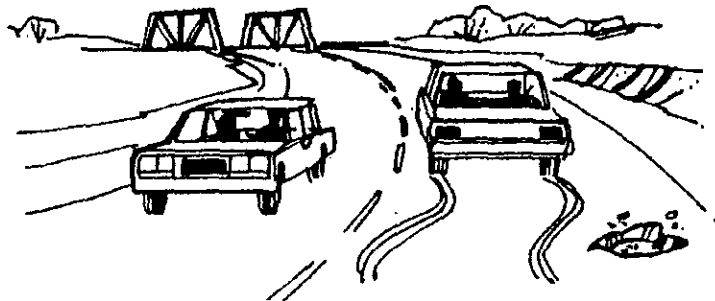

Choose Best Path of Travel

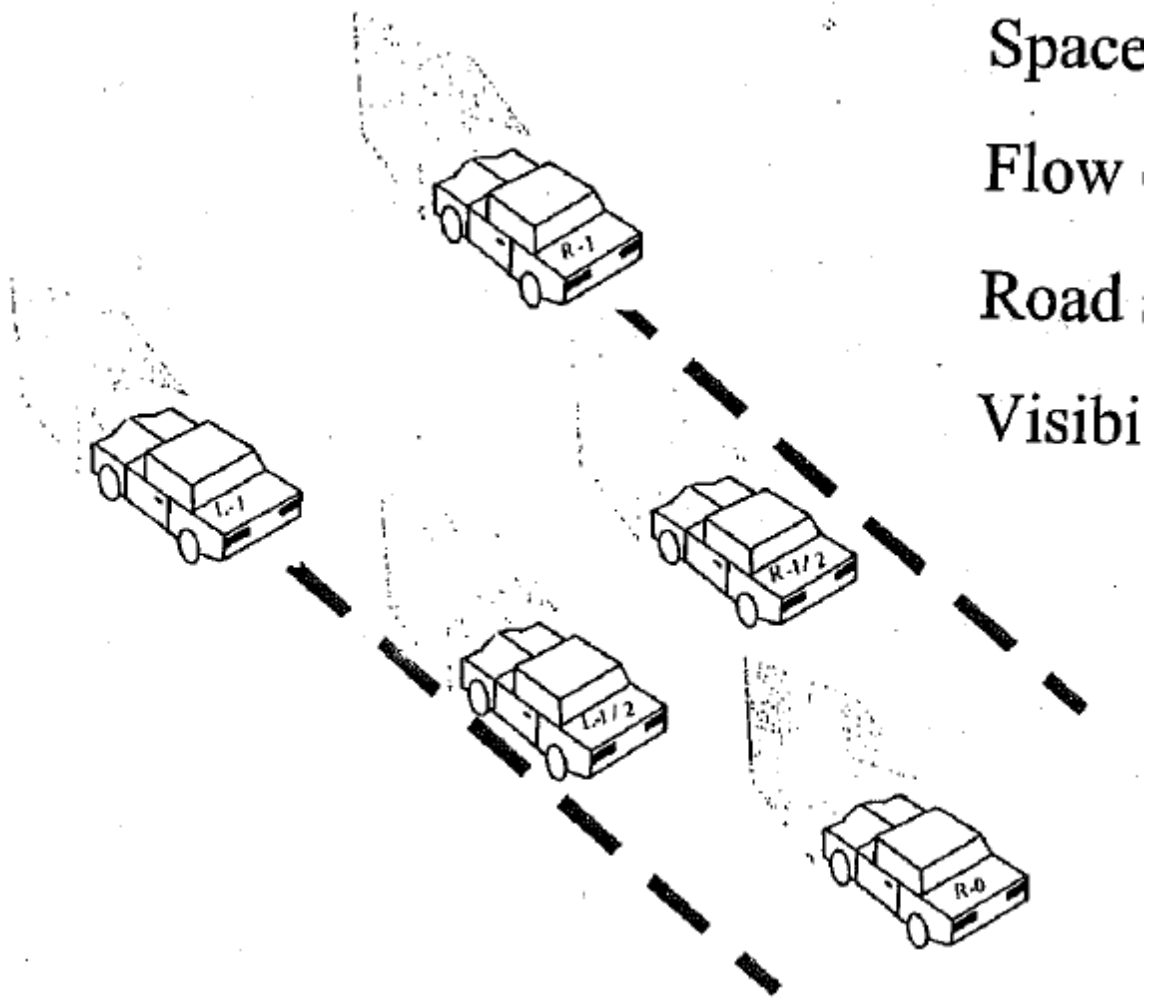

Space margin to sides?

Flow of traffic?

Road surface?

Visibility?

Communicate all Changes

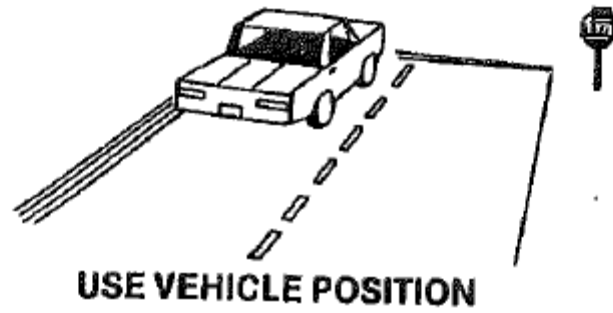
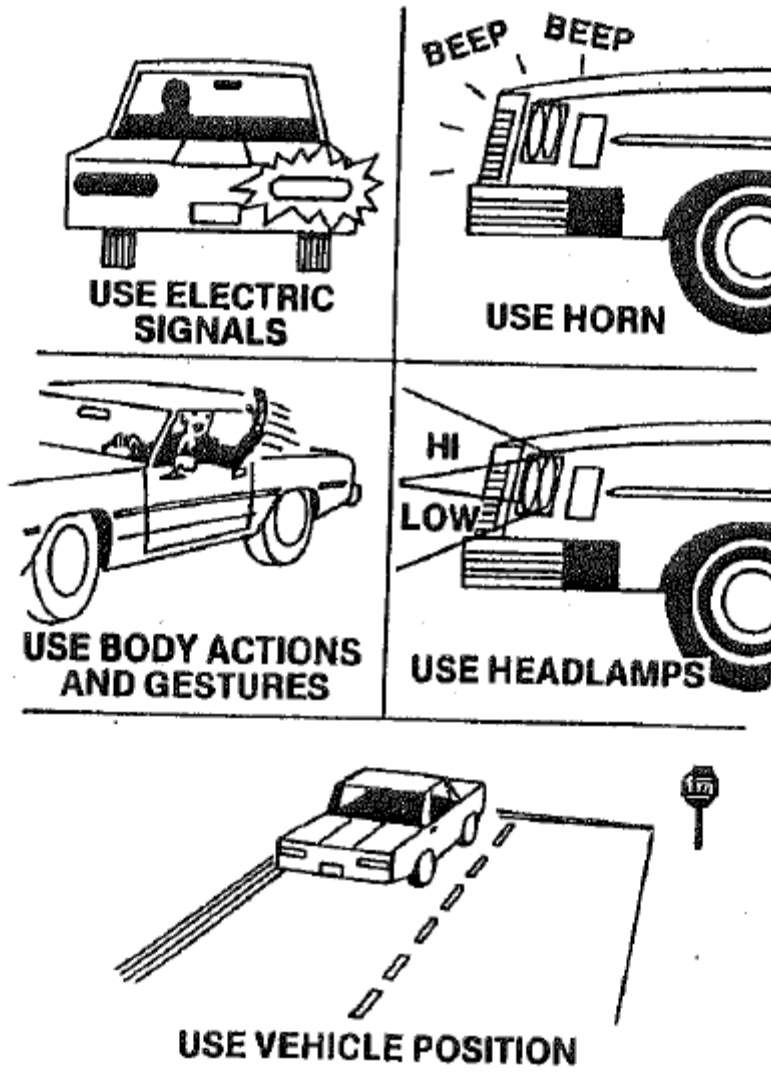

Case of the Narrow Median

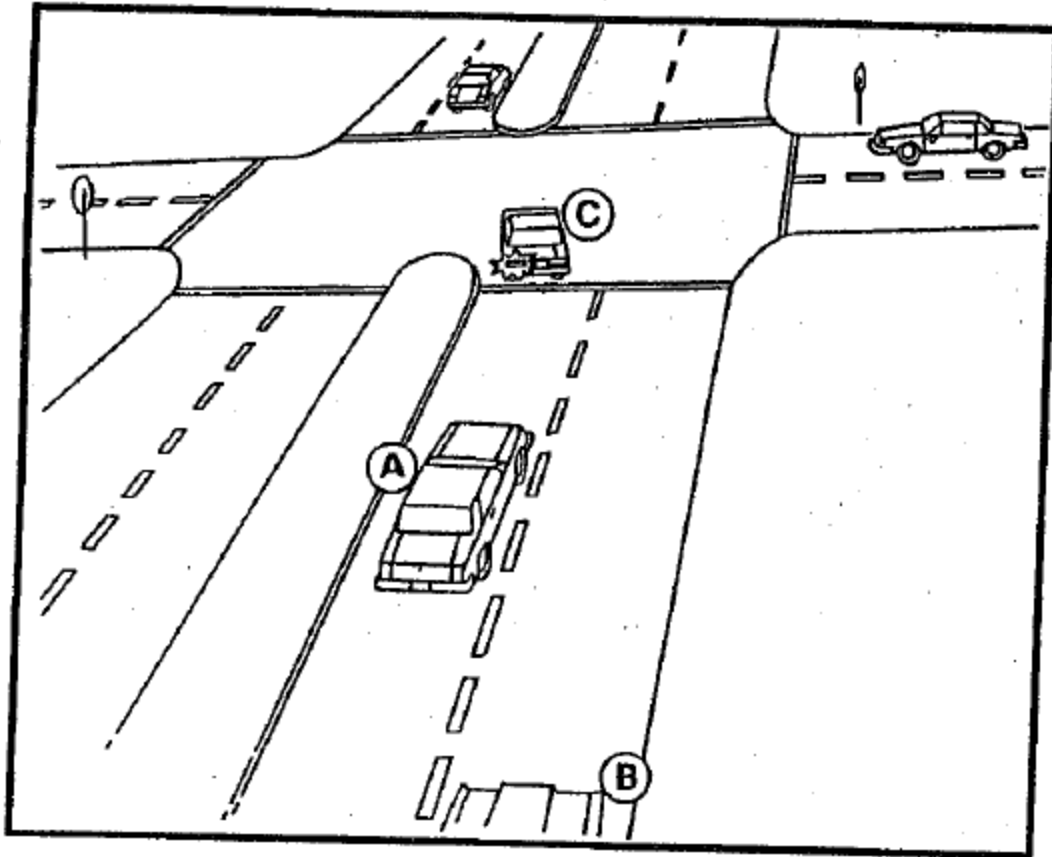

You are driving vehicle "A" on a four-lane divided highway. You are going 35 mph in a 40-mph zone. Car "C" is turning left and will not be able to complete the turn. You are not turning. Car "B" has been driving in the right lane and has maintained an approximate two second following distance on your car. You are continuing straight and are approximately six seconds from the intersection.

Case of the Merge Conflict

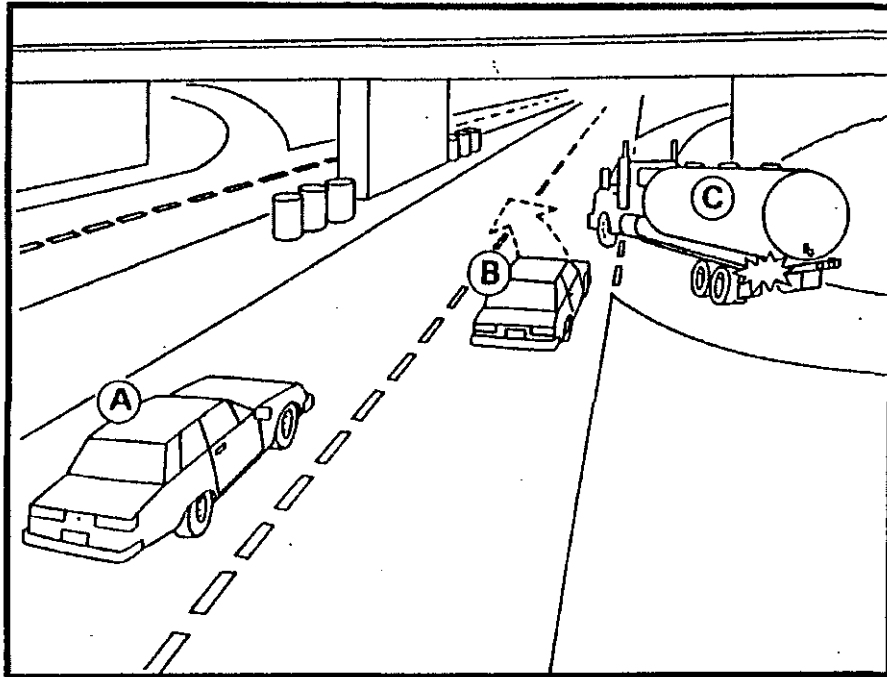

You are driving vehicle "A" on a divided highway. Just as you approach a merging situation, car "B" has been driving in lane two and was not planning on exiting. Your gap from "B" is approximately two seconds and the reason, you are in lane 1 is because you identified the tanker on the entrance ramp.

Case of the Hillcrest Hazard

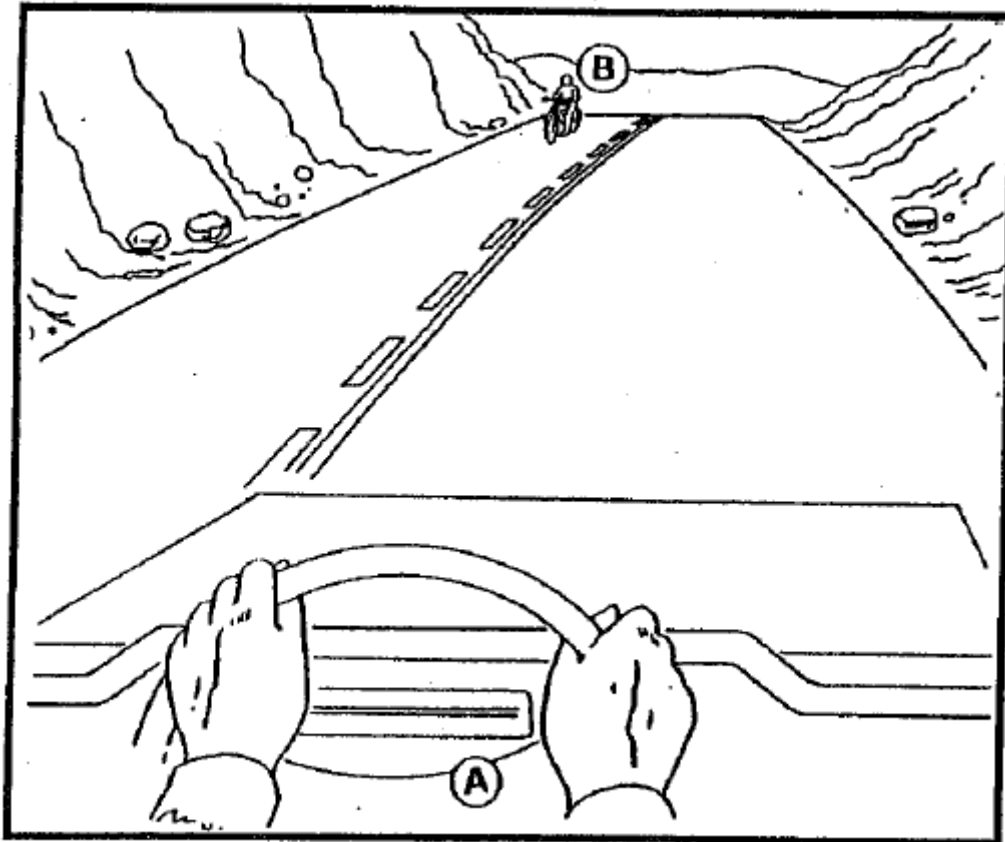

You are driving vehicle "A" about 55 mph on a rural highway. You are about three seconds from a hillcrest when suddenly bicyclist "B" appears over the hill. The shoulders are narrow. The bicyclist is near the center of his lane and appears to be an experienced rider.



R-4 Bicyclists on Open Highway



R-5 Stationary Bicyclist



R-6 Bicyclists on Urban Street



R-7 Turning Truck



R-8 Exiting at a Weave Lane Interchange



R-9 Parked Car on the Shoulder



R-10 Rural Railroad Crossing

Session Eight: Night Driving

Time:

Minimum of one class period and maximum of two class periods.

Purpose:

This program is designed to introduce the beginning driver to the risks associated with night driving and how to counteract the identified risks. Even experienced drivers are not aware of the serious problems that low-light conditions present. With the aid of the various transparencies and a selected video, the beginning drivers should demonstrate a greater awareness of the risks involved; also, how to respond to such risks. Those parts of the driver education text that would be most appropriate are Night Driving.

Materials/Equipment:

- Driver Education Text
- Overhead Projector or Power Point Video, e.g., "Night Driving"
- Monitor
- VCR Screen
- Selective Work Sheets
- Chalkboard

Program Objectives:

1. The student will identify the problems associated with night driving;
2. The student will identify and demonstrate pre-driving actions that are special for night driving;
3. The student will identify and demonstrate three visual searching techniques that help reduce the risks of night driving;
4. The student will describe and demonstrate visual techniques of reducing headlight glare from other vehicles;
5. The student will describe the term "overdriving headlights" and identify techniques that can reduce this risk; and
6. The student will identify certain maneuvers that possess a greater risk at night and explain how to reduce these risks.

Program Outline:

1. Introduction
2. Risks of driving at night
 - a. Total collisions
 - b. Reduced sight distance
 - c. Low reflective objects
 - d. Reaction time is lengthened
 - e. Glare

- f. Reduced depth perception
3. Special pre-ignition procedures
 - a. Prior to entering the vehicle
 - b. Cleaning windows and lights
 - c. Checking the various lights
 - d. Adjusting panel lights
 - e. Check day/night mirror
4. Special visual search techniques at night
 - a. Search to limits of headlights
 - b. Search beyond the headlight range
 - c. Search techniques to aid in tracking
5. Reducing glare
 - a. Approaching oncoming vehicles
 - b. Adjusting mirrors
6. Reducing the risk of overdriving headlights
 - a. Following distance
 - b. Use vehicle in front
 - c. Clues outside of headlight range
7. Reducing the risk of certain maneuvers at night
 - a. Turning
 - b. Backing
 - c. Changing lanes
 - d. Passing
 - e. Stopping on shoulder of highway
8. Program Summary

Guidelines for Conducting a Night Driving Program

Teaching Point	Rationale
Introduction to the Program	Night driving presents a great deal of problems for both inexperienced, as well as, experienced drivers. The problems are many, and new drivers need to be aware of these problems before attempting to counteract them. The problems and countermeasures will be introduced first in the classroom with a variety of audiovisuals. Once they are learned, you will be given the opportunity to transfer this learning to the car where you can apply and practice the various teaching techniques.
Show N-A Master. Show each objective as it is introduced.	With this program, you will be expected to learn and demonstrate the following objectives: The objectives are stated on the first page, and use N-A Master as you discuss each objective.
Show N-B Master.	Problems Associated with Driving at Night
This is the first problem associated with night driving.	<ul style="list-style-type: none"> • The risks of having a fatal collision are far greater at night than during the day.
Ask these questions and put responses on board.	<ol style="list-style-type: none"> 1. Comparing the difference between nighttime and daytime shows the Rural Areas 2.5 times greater and the Urban Areas 3 times greater.

Teaching Point	Rationale
	<ol style="list-style-type: none"> 2. Some 90 percent of driving clues are received by the eyes, and at night this is restricted. 3. Why are pedestrians at a greater risk in urban areas? As a pedestrian, how can you reduce this risk?
<p>Show N-C Master. This is the second problem associated with night driving.</p>	<p>Our sight distance is dramatically reduced at night. During daylight hours, you can see 20, 30 or more seconds in front of your vehicle. At night, this is dramatically reduced, and it depends on a variety of factors.</p> <ol style="list-style-type: none"> 1. With the vehicle not moving, high beams allow approximately 500 feet sight distance and low beams allow approximately 150 feet sight distance. 2. When the vehicle is moving at 30 mph, the low beam sight distance drops to approximately 90 feet. At 30 mph, this adds up to a little more than 2 seconds. With high beams, the sight distance is reduced to 300 feet.
<p>Show N-D Master. This is the third problem associated with night driving.</p>	<ul style="list-style-type: none"> • Low reflective objects at the side of the road are not visible beyond 70 feet. These objects may be pedestrians, animals and other utility vehicles. <ol style="list-style-type: none"> 1. Pedestrians can reduce this problem by wearing white colored clothing or shoes that have reflective material. 2. Animal eyes will reflect back as will lens covers on unlit vehicles. <p>Emphasize that these objects will be just outside of the headlight beam.</p>
<p>Show N-E Master. This is the fourth problem associated with night driving.</p>	<ul style="list-style-type: none"> • Our reaction time is significantly slowed at night, and this is due to the low light conditions and the need to focus longer on what you are attempting to identify and evaluate. <ol style="list-style-type: none"> 1. As you learned earlier, average reaction time during daylight hours is approximately: .7 of a second and this is when you are alert and searching for specific clues. Otherwise, it could be as long as 1.5 to 2.0 seconds. 2. At night, you can add anywhere from 1.5 to 2.0 seconds to your normal reaction time. Low light conditions require you to focus longer on something. 3. When looking at the various distances, remember that these distances do not include braking distance. This is only Reaction Distance.
<p>Show N-F Master. This is the fifth problem associated with night driving.</p>	<ul style="list-style-type: none"> • Glare from other vehicle headlights can dramatically reduce your vision, because the glare forces your pupils to constrict and thus further reducing your night vision.
<p>Show each point as it is discussed.</p>	<ol style="list-style-type: none"> 1. Headlight glare can affect your night vision from as far away as 3,000 feet. 2. Maximum visibility when both oncoming cars are using low beams is 200 feet. 3. When two approaching vehicles are 100 feet apart, your ability to see objects beside or beyond the oncoming vehicle is dramatically reduced.

Teaching Point	Rationale
	<ol style="list-style-type: none"> 4. When you are momentarily blinded by headlight glare, it can take as long as seven seconds before you fully recover from the glare. 5. Headlight glare is also a problem with vehicles that are behind or alongside your vehicle and the glare comes off of your rear view and/or side view mirrors directly into your eyes.
<p>Show N-G Master. This is the sixth problem associated with night driving.</p>	<ul style="list-style-type: none"> • Estimating speed and predicting closure of other vehicles at night is a significant problem, because all you have as reference points are headlights and taillights. <ol style="list-style-type: none"> 1. During daylight hours, you can use the roadway as a reference point and estimate speed and predict possible closure on your projected path of travel. 2. At night, you do not always have the ability to use the roadway as a reference point. Because of this, depth perception is significantly affected. This problem exists not only with oncoming vehicles but also with following and ongoing vehicles.
<p>Show N-H Master. This is the seventh problem associated with night driving.</p>	<ul style="list-style-type: none"> • The search patterns used at night are significantly different from those used during daylight hours. <ol style="list-style-type: none"> 1. When driving at night, you need to fixate for longer periods of time on each area of the environment. The reason for this is you need a longer period of time to acquire and process information. 2. Highways that do not have lighting systems require you to glance at the road edges and surfaces more frequently to assist in steering or tracking your vehicle.
<p>Show N-I Master. Uncover each procedure as it is introduced and discussed.</p>	<p>Special Pre-Driving Procedures for Night Driving</p> <p>To help address some of the problems associated with night driving, you should attempt to practice some special pre- ignition and ignition procedures. All you are doing is adding these to your regular pre-ignition and ignition procedure.</p> <ol style="list-style-type: none"> 1. Prior to entering your car, it is very important to check conditions along your intended path. This is especially important when backing your car. 2. Clean windows, inside and outside, are most important in reducing headlight and street light glare and increasing your visual acuity. 3. Clean headlights and taillights are also important, because the headlights will enable you to see better and the taillights will enable others to better see your vehicle. 4. Once your engine is started, turn on your headlights and work the high and low beam switch. The location and use of this switch can vary with different vehicles. 5. Adjust the panel lights to a desired intensity. A lower intensity is most desired in an area where the highway is not lighted. The lower intensity will reduce inside glare and reduce eye fatigue.

Teaching Point	Rationale
	<p>6. Check the day/night mirror. The night mirror is desired when glare is most evident. Driving in a well-lighted urban setting with a large volume of traffic, it is best to leave the mirror in the day position.</p> <p>7. If your side view mirrors are already turned slightly out to eliminate the left and right blind spots, no further adjustment is needed at night. If they are not turned slightly out, headlight glare from the sides will shine directly into your eyes.</p> <p>You can periodically check all of your lights by yourself at night, if you don't have someone to stand outside the vehicle to check the lights while you activate them. This can be done in the following manner:</p> <ol style="list-style-type: none"> 1. Place your vehicle so that it faces something in which you can see the reflection of the lights. 2. After the engine is running and the vehicle is in park or neutral (standard shift) and the emergency brake is set, turn your headlights on and check your high and low beams. 3. With the headlights off, check your left and right turn signals (front and back). You will see the flash behind you and in front. 4. With all lights off, check your brake lights by squeezing the brake pedal. You will be able to see the light intensity to the rear. 5. With all the lights off, emergency brake firmly set, foot on brake pedal, shift to Reverse and then slowly remove your foot from brake to check the back-up lights. If vehicle starts to move, squeeze the brake pedal. You need to get your emergency brake adjusted. <p>Once again, if you have a person to stand outside the vehicle to check your lights, then this is the preferred method. You should check your lights a minimum of once per month.</p>
<p>Show N-J Master. Show each technique as it is discussed.</p>	<p>Special Search Techniques to Use at Night</p> <p>Daylight driving allows you optimum sight distance which enables you to identify and evaluate real and/or potential hazards well ahead of your projected stopping distance. Daylight driving also allows you to easily maintain a selected lane position. At night these abilities are dramatically reduced; and to compensate for these problems, you need to use different search techniques.</p> <ol style="list-style-type: none"> 1. You must regularly search to the limit of your headlight range. When searching to the limit of your headlight range, you should be looking for: <ol style="list-style-type: none"> a. Low reflectorized control; b. Condition of roadway; and c. Low reflectorized objects in or near the roadway. 2. You should periodically search beyond the headlight range and use visible clues to evaluate roadway features and

Teaching Point	Rationale
	<p>traffic conditions. Visible clues beyond the headlight range are:</p> <ol style="list-style-type: none"> a. Highway reflectorized controls (signs, signals, markings). These enable you to identify certain roadway and highway features well ahead of your headlight range; b. Reflective material or objects on other users will enable you to identify something that may be in or near your projected path of travel; and c. Lights from other vehicles can be seen well beyond your headlight range. <p>There are all types of visual clues beyond your headlight range that you need to be aware of and how to search for them.</p> <ol style="list-style-type: none"> 3. To maintain an accurate path of travel at night, it is necessary to shift your eyes to near points to help you in tracking your vehicle. The recommended reference point is the right lane line or fog line. It is better to use the right lane instead of the left line. <p>Using these searching techniques will compensate some for reduced visibility, and it will also help prevent the common error of focusing only on the illuminated portion of the roadway. You also need to remember that low reflectorized objects or unlighted objects take longer to identify; and therefore, speed reduction is needed in certain situations.</p>
<p>Show N-K Master. Show each technique as it is presented.</p>	<p>Visual Techniques to Reduce Headlight Glare</p> <p>Headlight glare from approaching or ongoing vehicles can severely hinder your vision at night. To reduce the visual problems associated with headlight glare, there are certain visual techniques that you need to be aware of and be able to practice.</p> <ol style="list-style-type: none"> 1. A common error is to stare at the headlights of approaching vehicles. To avoid this, you should. Focus on the right lane line, move slightly to the right within your lane, and periodically glance at the oncoming vehicle to check its lane position. This technique will give you a safe margin in relation to the approaching vehicle. If there is a strong probability of pedestrians in the area, then a speed reduction is also needed because of the inability to see them when they are adjacent to the roadway with oncoming headlights. 2. Headlight glare from vehicles behind can be reduced with the rearview mirror adjusted to the night setting. Headlight glare from the sides can be reduced by turning the side mirrors slightly out.
<p>Show N-L Master. Show each technique as it is discussed.</p>	<p>Reducing the Risk of Overdriving Your Headlights</p> <p>Normally you want to reduce your speed at night to allow you to stop within the range of your headlights. Sometimes this might not</p>

Teaching Point	Rationale
	<p>always be possible, because you could be increasing the risk of being struck from behind. When the normal or mean speed exceeds a speed that increases the risk of overdriving your headlights, you can reduce the risk with selective techniques.</p> <ol style="list-style-type: none"> 1. Allow a greater following distance at night. You should use your following distance rule and add one second at night. 2. When following another vehicle, look beyond that vehicle and use its headlight range. 3. Aggressively search for clues outside of the lateral range of the headlights. <p>High Risk Maneuvers at Night</p> <p>Certain maneuvers performed at night possess a great deal more risk than during daylight hours. There are certain procedures that you can use that will reduce the inherent risks</p>
<p>Show N-M Master. Show each technique as it is discussed.</p>	<ul style="list-style-type: none"> • Making left and right turns and sharp curves. <p>When making turns at night on unlighted highways, the headlights illuminate the path that is in front of the vehicle. They do not go around the corners. To reduce the risks of turning at night on unlighted highways, you need to practice the following:</p> <ol style="list-style-type: none"> 1. Reduce speed on turns 2. Look through the turn beyond the lateral range of the headlights; and 3. Do not allow your eyes to only follow the headlights around the turn or corner.
<p>Show N-N Master. Show each technique as it is discussed.</p>	<ul style="list-style-type: none"> • Backing <p>When backing at night, lighting is minimal and this will affect the tracking of your vehicle. Backup lights provide minimal lighting, and they are primarily to warn others that you are in reverse and are preparing to back. To reduce the risks associated with backing your vehicle at night, practice the following:</p> <ol style="list-style-type: none"> 1. Visually check your intended path of travel before getting into the car. 2. Back slowly and look in the direction you are traveling.
<p>Show N-O Master. Show each technique as it is discussed.</p>	<ul style="list-style-type: none"> • Changing Lanes <p>Changing lanes at night presents a great deal more risk than during the daylight hours. Judging the closing speed of a vehicle from behind is extremely difficult when only seeing the headlights in your mirrors. Your depth perception from behind is dramatically reduced. To reduce the risk of pulling into another vehicle's path of travel, you can practice the following:</p> <ol style="list-style-type: none"> 1. Practice judging the speed of vehicles from behind by observing their movement and position of the headlights. 2. Allow for extra clearance to the rear before initiating a lane change.

Teaching Point	Rationale
<p>Show N-P Master. Show each risk as it is discussed.</p>	<ul style="list-style-type: none"> • Passing Another Ongoing Vehicle <p>Passing left of center. on a two-lane road is a high-risk maneuver during the daylight, and it is even a greater risk at night. Some of the risks are:</p> <ol style="list-style-type: none"> 1. Your headlight range does not allow for a complete evaluation of the roadway (hills, curves, intersections). 2. When passing, you need a greater speed, and this results in overdriving your headlights; and 3. Other drivers can have difficulty determining when another vehicle is passing, because they only see headlights. <p>Passing at night poses multiple risks, and the reasons for passing seldom justify the involved risks.</p>
<p>Show N-Q Master. Show each step to take as it is discussed.</p>	<ul style="list-style-type: none"> • Stopping Along the Shoulder of the Highway <p>The risk of stopping along the shoulder of a highway at night is being struck from behind by another vehicle. To reduce this risk, you can practice the following:</p> <ol style="list-style-type: none"> 1. Unless it is an emergency, you should only stop at well-lit areas; 2. If it is an emergency, then pull off onto the shoulder as far from the roadway as possible; 3. Activate your four-way flashers to warn other drivers of your position 4. If you have flares or reflectors, place these behind your vehicle in a line to warn other motorists so that they steer away from you as they approach; and 5. If there is a safe area for the passengers to stand then have them move away from the vehicle.

Summary

Driving at night possesses a great many inherent risks for both the inexperienced and experienced driver. Being aware of the risks and knowing how to control these risks, to some degree, is the first step in reducing the probability of a collision. The opportunity to practice in selective driving environments at night with adult supervision is a critical part of the learning process. The state curriculum lesson plans for night driving describes selective environments in relation to their degree of difficulty. Certain environments are easier to drive in than others, and the easier environments should be mastered before moving onto the more difficult environments. The degree of difficulty is usually related to the speed of the environment. The slower the speed, the better the risks can be controlled.

Adverse conditions should be addressed after the night driving program, because these are conditions that affect visibility and many of the countermeasures used at night are similar for adverse conditions.

Objectives

1. Problems associated with night driving
2. Special pre-driving procedures for night driving
3. Visual searching techniques for night driving
4. Reducing glare associated with night driving
5. Reducing the risk of overdriving your headlights

Night Time Death Rate vs. Day Time Death Rate

Rural Areas—2 ½ times greater

Urban Areas 3 times greater

Sight Distance at Night

1. Stationary Vehicle
 - a. Low Beams: 150 feet
 - b. High Beams: 500 feet
2. Vehicle Moving at 30 MPH
 - a. Low Beams: 90 feet
 - b. High Beams: 300 feet

Low Reflective Objects

Any person, vehicle or animal that is adjacent to the roadway with little to no reflection is difficult to see beyond 70 feet.

Slower Reaction Time

At night, you can add anywhere from 1.5 to 2.0 seconds reaction distance to your normal reaction distance.

Reaction Distance = Speed * 1.47 * Reaction Time * Night Reaction Time

Normal Reaction Time	Night Reaction Time
.75 at 35 mph (Day)= 39 feet	at night= 58 feet
.75 at 55 mph (Day)= 61 feet	at night = 91 feet
1.0 at 35 mph (Day)= 52 feet	at night = 77 feet
1.0 at 55 mph (Day)= 81 feet	at night = 121 feet

Headlight Glare

- Approaching vehicle on low beam, maximum visibility is 200 feet
- When approaching vehicle is on low beam at 100 feet distance, the ability to see objectives adjacent to-roadway is reduced
- Can be momentarily blinded for as long as 7 seconds
- Vehicles behind and alongside

Depth Perception

- Estimating closing speed of oncoming vehicles and following vehicles
- Estimating closing speed of ongoing vehicle

Search Patterns

- Need to fixate longer on objects
- Need to check edge of road

Special Pre-Ignition and Ignition Procedures

1. Check Intended Path of Vehicle
2. Clean Windows and Lights
3. High/Low Beam
4. Panel Lights
5. Rearview Mirror
6. Side View Mirrors
7. Periodic Check of All Lights

Special Search Techniques

1. Search to the limits of your headlights range
2. Periodically search beyond the range of headlights
3. Use the right lane edge line or fog line to help in positioning your vehicle

Reducing Headlight Glare

1. Use right lane line with approaching vehicle
2. Adjust mirrors

Reducing Risk of Overdriving Headlights

1. Increase your following distance
2. Use headlights of ongoing vehicles
3. Visual clues outside of lateral range of headlights

Turns and Curves

1. Reduce Speed
2. Search beyond the lateral range of the headlights
3. Don't allow eyes to only follow headlight range

Backing

1. Check intended path
2. Slow speed and look in direction

Changing Lanes

1. Practice judging closing speed of vehicles from behind
2. Allow extra clearance

Risks of Passing at Night

1. Limited range of headlights
2. Overdriving headlights
3. Other driver's inability to determine speed of closure

*Reasons for passing at night seldom justify the risks

Stopping Along Shoulder of Highway

1. Unless emergency, Don't
2. As far off roadway as shoulders allow
3. Four-Way Flashers
4. Flares or Reflectors
5. Safest Area for Passengers

Appendix A

Answer Sheets for Sessions

Perception of HTS Events Answer Sheet

Name:

Total score (out of 36):

VISUALIZE! DON'T VERBALIZE. SEE IT! DON'T SAY IT.

For scoring purposes, circle those correct and X out those incorrect. Thank You!

Traffic Controls

1. C-1: A B C
2. C-2: A B C
3. C-3: A B C
4. C-4: A B C
5. C-5: A B C
6. C-6: A B C
7. C-7: A B C

Test Slides:

1. C-8: A B C
2. C-9: A B C
3. C-10: A B C

"C" Test Score:

Highway Conditions:

1. H-1: A B C
2. H-2: A B C
3. H-3: A B C
4. H-4: A B C
5. H-5: A B C
6. H-6: A B C
7. H-7: A B C

Test Slides:

1. H-8: A B C
2. H-9: A B C
3. H-10: A B C

"H" Test Score:

Other Users:

- | | | | | |
|----|------|---|---|---|
| 1. | O-1: | A | B | C |
| 2. | O-2: | A | B | C |
| 3. | O-3: | A | B | C |
| 4. | O-4: | A | B | C |
| 5. | O-5: | A | B | C |
| 6. | O-6: | A | B | C |
| 7. | O-7: | A | B | C |

Test Slides:

- | | | | | |
|----|-------|---|---|---|
| 1. | O-8: | A | B | C |
| 2. | O-9: | A | B | C |
| 3. | O-10: | A | B | C |

“O” Test Score:

All Groups

- | | | | | |
|----|------|---|---|---|
| 1. | A-1: | A | B | C |
| 2. | A-2: | A | B | C |
| 3. | A-3: | A | B | C |
| 4. | A-4: | A | B | C |
| 5. | A-5: | A | B | C |
| 6. | A-6: | A | B | C |
| 7. | A-7: | A | B | C |

Test Slides:

- | | | | | |
|----|-------|---|---|---|
| 1. | A-8: | A | B | C |
| 2. | A-9: | A | B | C |
| 3. | A-10: | A | B | C |

“A” Test Score:

Answer Sheet for Case Study Evaluations

Case Title:

Name:

1. There is a high conflict probability on your 12 seconds path.
 - a. True
 - b. False
2. When will the probable conflict take place?
 - a. Within 2 seconds part of path.
 - b. Within 2-4 seconds part of path.
 - c. Within 5-12 seconds part of path.
 - d. Outside 12 seconds path of travel.
3. About how much of your pathway or lane will be used? Circle letter of one.
 - a. One-fourth
 - b. One-half
 - c. All
 - d. None
4. What are the contributing factors?
 - a. Space
 - b. Visibility
 - c. Traction
 - d. Law Violation
 - e. Other User Error
 - f. Other:

Case Title:

1. There is a high conflict probability on your 12 seconds path.
 - a. True
 - b. False
2. When will the probable conflict take place?
 - a. Within 2 seconds part of path.
 - b. Within 2-4 seconds part of path.
 - c. Within 5-12 seconds part of path.
 - d. Outside 12 seconds path of travel.
3. About how much of your pathway or lane will be used? Circle letter of one.
 - a. One-fourth
 - b. One-half
 - c. All
 - d. None

4. What are the contributing factors?
 - a. Space
 - b. Visibility
 - c. Traction
 - d. Law Violation
 - e. Other User Error
 - f. Other:

Case Title:

1. There is a high conflict probability on your 12 seconds path.
 - a. True
 - b. False
2. When will the probable conflict take place?
 - a. Within 2 seconds part of path.
 - b. Within 2-4 seconds part of path.
 - c. Within 5-12 seconds part of path.
 - d. Outside 12 seconds path of travel.
3. About how much of your pathway or lane will be used? Circle letter of one.
 - a. One-fourth
 - b. One-half
 - c. All
 - d. None
4. What are the contributing factors?
 - a. Space
 - b. Visibility
 - c. Traction
 - d. Law Violation
 - e. Other User Error
 - f. Other:

Case Title:

1. There is a high conflict probability on your 12 seconds path.
 - a. True
 - b. False
2. When will the probable conflict take place?
 - a. Within 2 seconds part of path.
 - b. Within 2-4 seconds part of path.
 - c. Within 5-12 seconds part of path.
 - d. Outside 12 seconds path of travel.

3. About how much of your pathway or lane will be used? Circle letter of one.
 - a. One-fourth
 - b. One-half
 - c. All
 - d. None
4. What are the contributing factors?
 - a. Space
 - b. Visibility
 - c. Traction
 - d. Law Violation
 - e. Other User Error
 - f. Other:

Case Title:

1. There is a high conflict probability on your 12 seconds path.
 - a. True
 - b. False
2. When will the probable conflict take place?
 - a. Within 2 seconds part of path.
 - b. Within 2-4 seconds part of path.
 - c. Within 5-12 seconds part of path.
 - d. Outside 12 seconds path of travel.
3. About how much of your pathway or lane will be used? Circle letter of one.
 - a. One-fourth
 - b. One-half
 - c. All
 - d. None
4. What are the contributing factors?
 - a. Space
 - b. Visibility
 - c. Traction
 - d. Law Violation
 - e. Other User Error
 - f. Other:

Case Title:

1. There is a high conflict probability on your 12 seconds path.
 - a. True
 - b. False

2. When will the probable conflict take place?
 - a. Within 2 seconds part of path.
 - b. Within 2-4 seconds part of path.
 - c. Within 5-12 seconds part of path.
 - d. Outside 12 seconds path of travel.
3. About how much of your pathway or lane will be used? Circle letter of one.
 - a. One-fourth
 - b. One-half
 - c. All
 - d. None
4. What are the contributing factors?
 - a. Space
 - b. Visibility
 - c. Traction
 - d. Law Violation
 - e. Other User Error
 - f. Other:

Appendix B

Extra Case Study Diagrams

Case of the Truck Turning

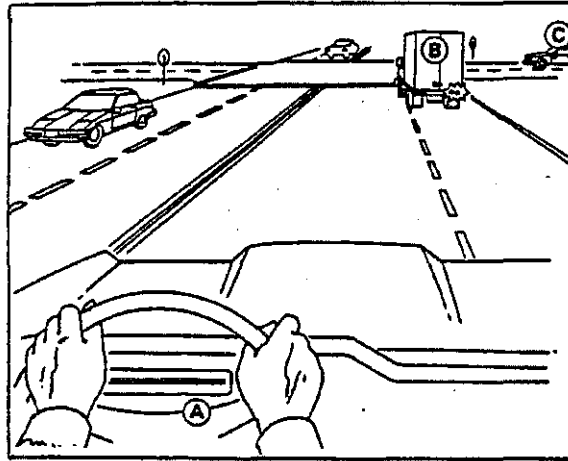

You are driving straight ahead in car "A". Truck "B" is preparing to turn right.

Case of the Supermarket Shopper

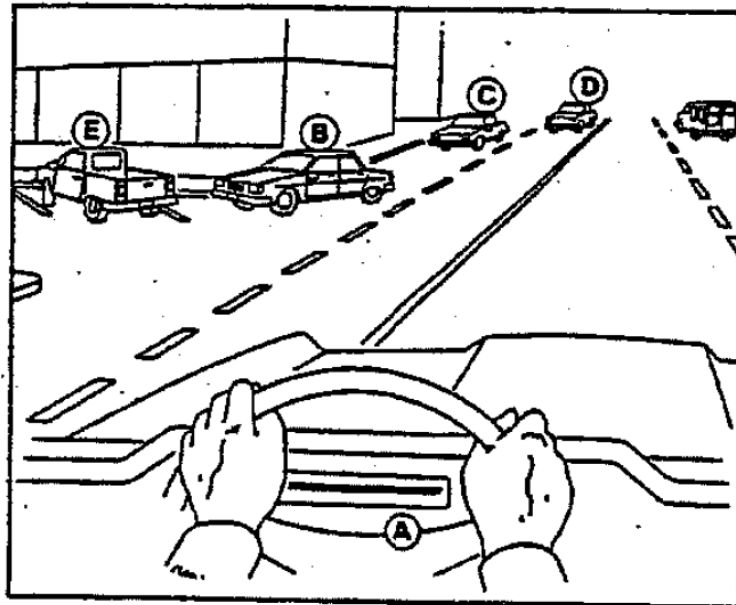

You are driving car "A" about 30 MPH in a business district. You can see that car "B" will not be able to complete the turn because care "E" is backing out.

Car "C" and car "D" cannot see car "E". Car "C" is following about 2 seconds behind car "B". Also, car "D" is driving in the blind spot of car "C".

Case of the Follow-tail Passer

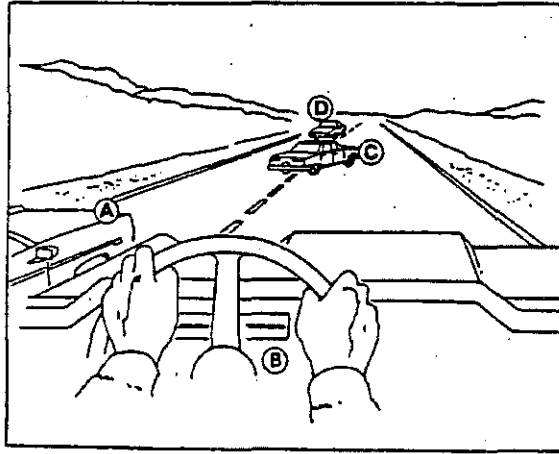

You are driving car "A" on a two-lane highway. You are following care "C" around car "B". The front of your car is almost even with the front of car "B". All of a sudden you realize car "D" is closer than you through.

Case of the Hidden Biker

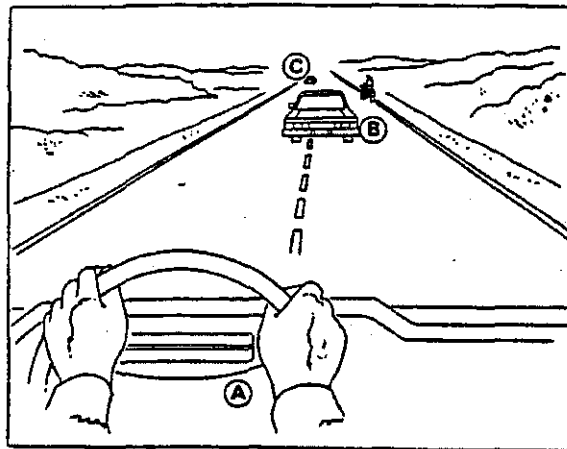

You are driving car "A" on a two-lane highway. Since car "D" is a safe distance away, you start to pass car "B". Just then, car "B" moves left part way across the center line. You know why when the bike comes into view.

Case of the Impatient Passer

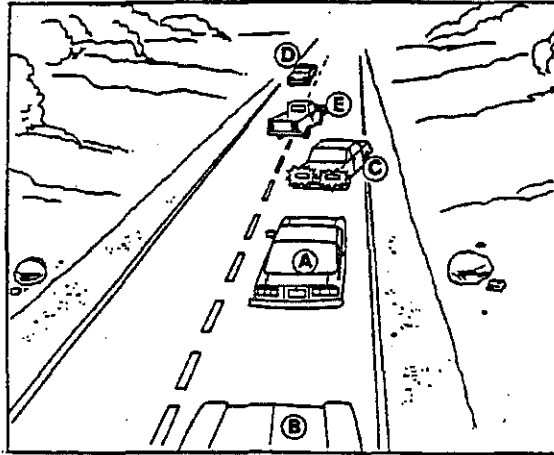

You are driving car "A" in a line of cars on a two-lane highway. Car "E" is passing and cuts in front of car "C" to miss car "D". Car "C" flashes the brake lights and steers toward the shoulder.

Case of the Right Shoulder Hazard

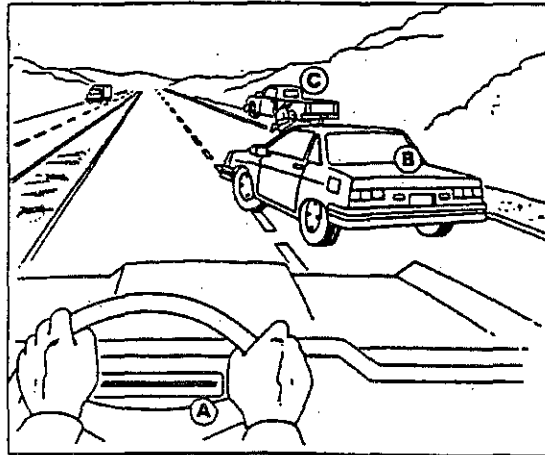

You are driving car "A" on a four-lane divided highway with wide shoulders. You are starting to pass car "B". Suddenly, without signaling, car "B" swerves onto your lane to avoid coming close to the driving of car "C" at the side of the road.

Case of the Strong Crosswind

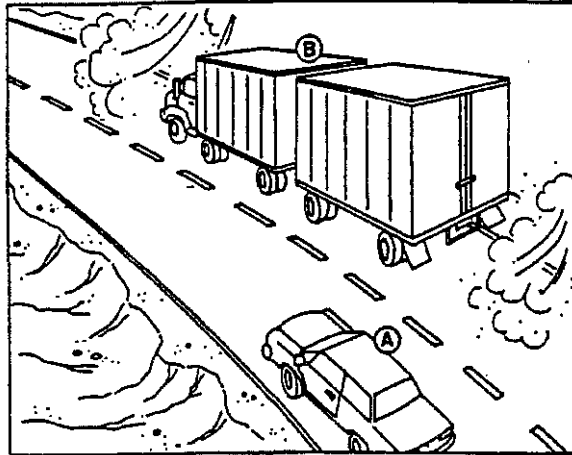

You are driving car "A" about 50 MPH on a two-lane rural highway in a strong cross wind from the right. The shoulders are uneven with the pavement and a little narrow. You are about to pass a large double trailer truck.

Case of the Oncoming Passer

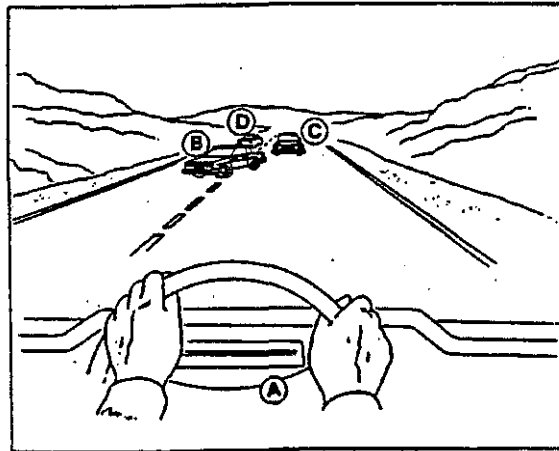

You are driving car "A" on a two-lane highway. Car "B" has just completed passing car "D". Car "C" is also trying to pass car "D", but has misjudged the space needed. You are faced with a good chance for a head-on crash.

Case of the Blocked View

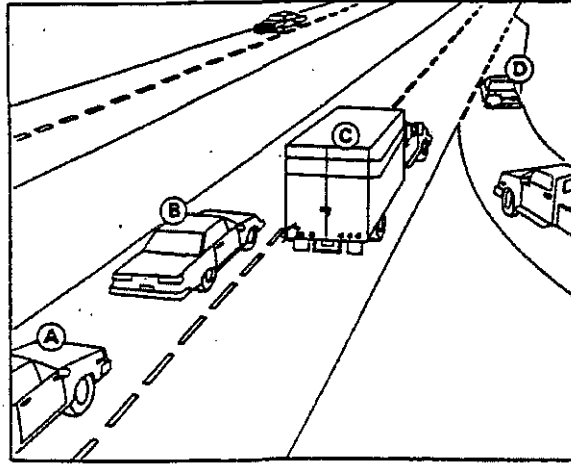

You are driving car "A" and following car "B" at an interchange. Car "B" cannot see the merging vehicles. Truck "C" is signaling a lane change.

Case of the Busy Ramp

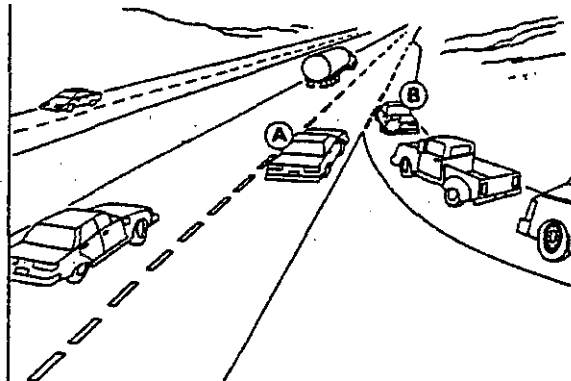

You are driving car "A" on an expressway. Car "B" is speeding up to merge onto the expressway. There is a line of cars waiting to merge.

Case of the Blindspot Driver

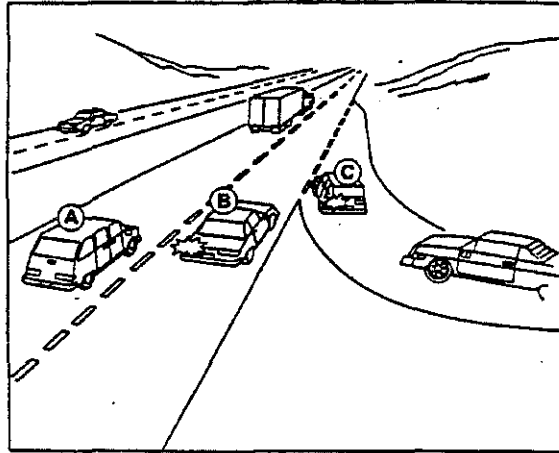

You are driving car "A" on an expressway in the blind spot of car "B". Car "C" is speeding up to merge onto the expressway. Car "B" is signaling for a lane change and has started to drift toward the lane line.

Case of the Crowded Freeway

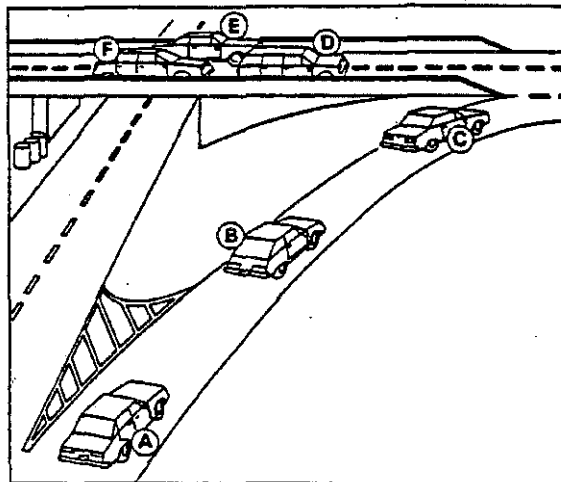

You are driving car "B" on a ramp at an interchange. You are about one second away from car "C" and car "A". Car "F" is tailgating car "D" on the freeway. Car "C" is beginning to speed up.

Case of the Right-Side Passer

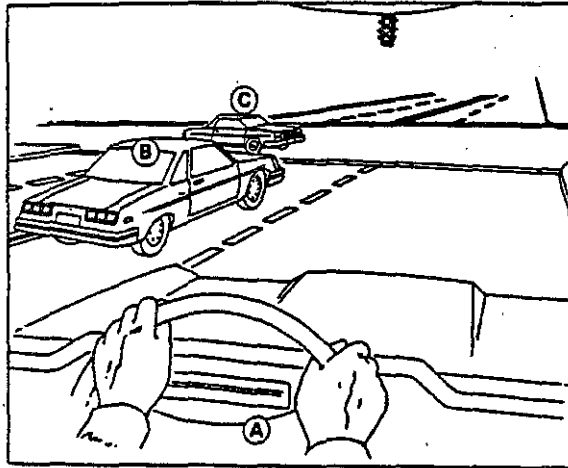

You are coming to an intersection in car "A". The light changes to green, but car "B" is slow to move, so you decide to pass, just as you reach the corner, you can see that car "C" is speeding up to beat the light change.

Case of the Hidden Motorcycle

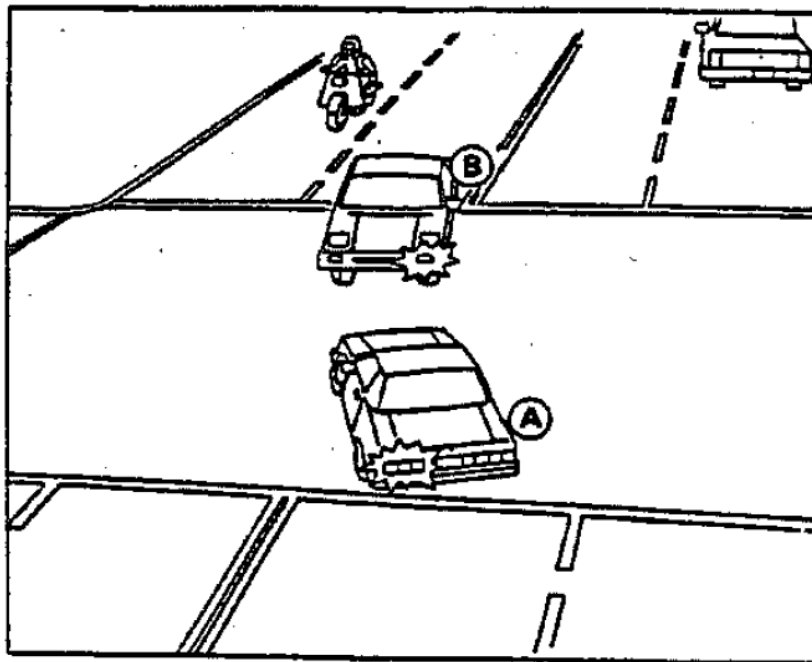

You are starting to turn left in car "A". At the same time, car "B" is making a left turn opposite you. Just as you start to pass "B", you see a motorcycle coming at you.

Case of the Hidden Gravel Road

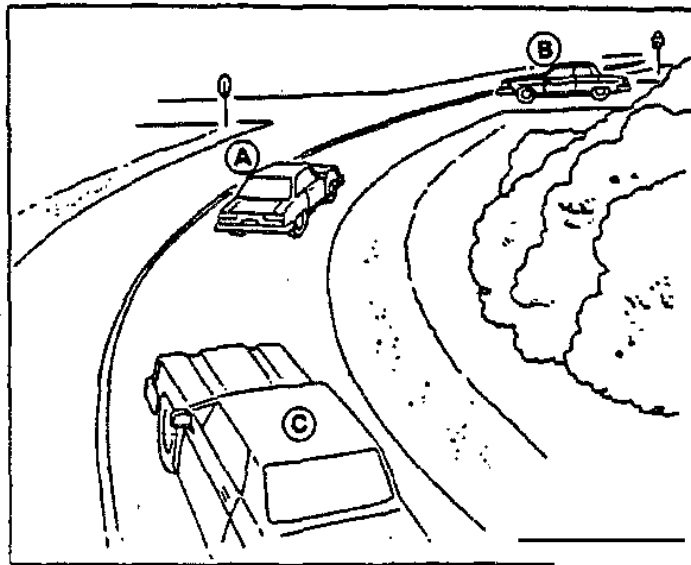

You are driving car "A" about 50 MPH on a two-lane rural highway. You have just come around a curve on a downgrade, and you are about four seconds from the side road. Suddenly, car "B" starts moving across the intersection from the right.

Appendix C

Checklists for In-Car Lessons

Checklist for 2--4-- 12 Time Distances

General Instructions

You will practice at least five trials for each of the timed distances. You will also be asked to be the timer-recorder when you are not practicing. The average time of the five trials will be your score. A stopwatch or wristwatch will be used as a timing device.

Two-Second Following Distance

The one practicing this timed distance will verbally identify a fixed checkpoint where the counting is to start. One can practice as a driver or observer. The one timing and recording will record the number of seconds for each trial.

Four-Second Stopping Zone & Twelve-Second Visual Lead

The person practicing will:

- a. Pick a fixed object along the roadside which is thought to be four or twelve seconds ahead of the car.
- b. When the object is picked, tell the timer, "START".
- c. When the object is passed, tell the timer, "STOP".

The person recording and timing will:

- a. Start and stop the watch when your classmate tells you.
- b. Read the time, write it in the space provided, and tell the time to your classmate.
 1. Name of Driver:
 - a. 2 seconds
 - i. Trial 1:
 - ii. Trial 2:
 - iii. Trial 3:
 - iv. Trial 4:
 - v. Trial 5:
 - vi. Total:
 - vii. Average
 - b. 4 seconds
 - i. Trial 1:
 - ii. Trial 2:
 - iii. Trial 3:
 - iv. Trial 4:
 - v. Trial 5:
 - vi. Total:
 - vii. Average

- c. 12 seconds
 - i. Trial 1:
 - ii. Trial 2:
 - iii. Trial 3:
 - iv. Trial 4:
 - v. Trial 5:
 - vi. Total:
 - vii. Average
- 2. Name of Driver:
 - a. 2 seconds
 - i. Trial 1:
 - ii. Trial 2:
 - iii. Trial 3:
 - iv. Trial 4:
 - v. Trial 5:
 - vi. Total:
 - vii. Average
 - b. 4 seconds
 - i. Trial 1:
 - ii. Trial 2:
 - iii. Trial 3:
 - iv. Trial 4:
 - v. Trial 5:
 - vi. Total:
 - vii. Average
 - c. 12 seconds
 - i. Trial 1:
 - ii. Trial 2:
 - iii. Trial 3:
 - iv. Trial 4:
 - v. Trial 5:
 - vi. Total:
 - vii. Average
- 3. Name of Driver:
 - a. 2 seconds
 - i. Trial 1:
 - ii. Trial 2:
 - iii. Trial 3:
 - iv. Trial 4:
 - v. Trial 5:
 - vi. Total:
 - vii. Average

- b. 4 seconds
 - i. Trial 1:
 - ii. Trial 2:
 - iii. Trial 3:
 - iv. Trial 4:
 - v. Trial 5:
 - vi. Total:
 - vii. Average
- c. 12 seconds
 - i. Trial 1:
 - ii. Trial 2:
 - iii. Trial 3:
 - iv. Trial 4:
 - v. Trial 5:
 - vi. Total:
 - vii. Average

Checklist for Conflict Probabilities

Observer or Driver Instruction

In advance of each block or part of the roadway, you will orally indicate whether the path ahead is "CLEAR" or "NOT CLEAR". For each not clear situation, you will tell when and where the hazards are with a high chance of conflict. You will have a choice of three conflict locations that make up part of the intended pathway-- (1) between two and four seconds, (2) between four and twelve seconds, and (3) over twelve seconds.

Recorder Instructions

Check (X) in the proper column for the conflict locations picked for "NOT CLEAR" situations. After two of these situations, park along the curb to discuss. Then, score (C) for correct and (*check*) for incorrect.

1. Name
 - a. Trial 1:
 - i. 2-4 Seconds:
 - ii. 4-12 seconds:
 - iii. Over 12:
 - iv. Score:
 - b. Trial 2:
 - i. 2-4 Seconds:
 - ii. 4-12 seconds:
 - iii. Over 12:
 - iv. Score:
 - c. Trial 3:
 - i. 2-4 Seconds:
 - ii. 4-12 seconds:
 - iii. Over 12:
 - iv. Score:
 - d. Trial 4:
 - i. 2-4 Seconds:
 - ii. 4-12 seconds:
 - iii. Over 12:
 - iv. Score:
2. Name
 - a. Trial 1:
 - i. 2-4 Seconds:
 - ii. 4-12 seconds:
 - iii. Over 12:
 - iv. Score:

- b. Trial 2:
 - i. 2-4 Seconds:
 - ii. 4-12 seconds:
 - iii. Over 12:
 - iv. Score:
 - c. Trial 3:
 - i. 2-4 Seconds:
 - ii. 4-12 seconds:
 - iii. Over 12:
 - iv. Score:
 - d. Trial 4:
 - i. 2-4 Seconds:
 - ii. 4-12 seconds:
 - iii. Over 12:
 - iv. Score:
3. Name
- a. Trial 1:
 - i. 2-4 Seconds:
 - ii. 4-12 seconds:
 - iii. Over 12:
 - iv. Score:
 - b. Trial 2:
 - i. 2-4 Seconds:
 - ii. 4-12 seconds:
 - iii. Over 12:
 - iv. Score:
 - c. Trial 3:
 - i. 2-4 Seconds:
 - ii. 4-12 seconds:
 - iii. Over 12:
 - iv. Score:
 - d. Trial 4:
 - i. 2-4 Seconds:
 - ii. 4-12 seconds:
 - iii. Over 12:
 - iv. Score:

Checklist for Timing Situations

Driver Instructions

Use the commentary driving method to identify where you would meet an oncoming car at your present speed. Then decide where best to meet and adjust speed.

Observer Instructions

Check the speed change you see the driver make. Then decide whether the driver chose a better place to meet the oncoming car in terms of space, visibility, or traction. Score (C) for correct and (check) for incorrect.

1. Name:
 - a. Trial 1:
 - i. Speed change:
 1. Increase?
 2. Same?
 3. Decrease?
 - ii. Better place:
 1. Yes
 2. No
 - iii. Score:
 - b. Trial 2:
 - i. Speed change:
 1. Increase?
 2. Same?
 3. Decrease?
 - ii. Better place:
 1. Yes
 2. No
 - iii. Score:
 - c. Trial 3:
 - i. Speed change:
 1. Increase?
 2. Same?
 3. Decrease?
 - ii. Better place:
 1. Yes
 2. No
 - iii. Score:

- d. Trial 4:
 - i. Speed change:
 - 1. Increase?
 - 2. Same?
 - 3. Decrease?
 - ii. Better place:
 - 1. Yes
 - 2. No
 - iii. Score:
 - e. Trial 5:
 - i. Speed change:
 - 1. Increase?
 - 2. Same?
 - 3. Decrease?
 - ii. Better place:
 - 1. Yes
 - 2. No
 - iii. Score:
2. Name:
- a. Trial 1:
 - i. Speed change:
 - 1. Increase?
 - 2. Same?
 - 3. Decrease?
 - ii. Better place:
 - 1. Yes
 - 2. No
 - iii. Score:
 - b. Trial 2:
 - i. Speed change:
 - 1. Increase?
 - 2. Same?
 - 3. Decrease?
 - ii. Better place:
 - 1. Yes
 - 2. No
 - iii. Score:

- c. Trial 3:
 - i. Speed change:
 - 1. Increase?
 - 2. Same?
 - 3. Decrease?
 - ii. Better place:
 - 1. Yes
 - 2. No
 - iii. Score:
 - d. Trial 4:
 - i. Speed change:
 - 1. Increase?
 - 2. Same?
 - 3. Decrease?
 - ii. Better place:
 - 1. Yes
 - 2. No
 - iii. Score:
 - e. Trial 5:
 - i. Speed change:
 - 1. Increase?
 - 2. Same?
 - 3. Decrease?
 - ii. Better place:
 - 1. Yes
 - 2. No
 - iii. Score:
3. Name:
- a. Trial 1:
 - i. Speed change:
 - 1. Increase?
 - 2. Same?
 - 3. Decrease?
 - ii. Better place:
 - 1. Yes
 - 2. No
 - iii. Score:

- b. Trial 2:
 - i. Speed change:
 - 1. Increase?
 - 2. Same?
 - 3. Decrease?
 - ii. Better place:
 - 1. Yes
 - 2. No
 - iii. Score:
- c. Trial 3:
 - i. Speed change:
 - 1. Increase?
 - 2. Same?
 - 3. Decrease?
 - ii. Better place:
 - 1. Yes
 - 2. No
 - iii. Score:
- d. Trial 4:
 - i. Speed change:
 - 1. Increase?
 - 2. Same?
 - 3. Decrease?
 - ii. Better place:
 - 1. Yes
 - 2. No
 - iii. Score:
- e. Trial 5:
 - i. Speed change:
 - 1. Increase?
 - 2. Same?
 - 3. Decrease?
 - ii. Better place:
 - 1. Yes
 - 2. No
 - iii. Score:

Checklist for Choosing Best Pathway

Driver Instructions

Use the commentary driving to identify situations that should require a response in positioning. Then choose and make your response.

Observer Instructions

Record the choices taken by the driver. Then after a discussion, score (C) for correct and (check) for incorrect.

CODES USED:

LCL or LCR: Lane change to the left or lane change to the right.

L-1 or R-1: To the left or right one car width.

L-1/2 or R-1/2: On-half car width to the left or to right.

1. Name:

a. Trial 1: Choice of Path:

- i. LCL
- ii. L-1
- iii. L-1/2
- iv. OO
- v. R-1/2
- vi. R-1
- vii. LCR

b. Score:

c. Trial 2: Choice of Path:

- i. LCL
- ii. L-1
- iii. L-1/2
- iv. OO
- v. R-1/2
- vi. R-1
- vii. LCR

d. Score:

- e. Trial 3: Choice of Path:
 - i. LCL
 - ii. L-1
 - iii. L-1/2
 - iv. OO
 - v. R-1/2
 - vi. R-1
 - vii. LCR
 - f. Score:
 - g. Trial 4: Choice of Path:
 - i. LCL
 - ii. L-1
 - iii. L-1/2
 - iv. OO
 - v. R-1/2
 - vi. R-1
 - vii. LCR
 - h. Score:
2. Name:
- a. Trial 1: Choice of Path:
 - i. LCL
 - ii. L-1
 - iii. L-1/2
 - iv. OO
 - v. R-1/2
 - vi. R-1
 - vii. LCR
 - b. Score:
 - c. Trial 2: Choice of Path:
 - i. LCL
 - ii. L-1
 - iii. L-1/2
 - iv. OO
 - v. R-1/2
 - vi. R-1
 - vii. LCR
 - d. Score:

- e. Trial 3: Choice of Path:
 - i. LCL
 - ii. L-1
 - iii. L-1/2
 - iv. OO
 - v. R-1/2
 - vi. R-1
 - vii. LCR
 - f. Score:
 - g. Trial 4: Choice of Path:
 - i. LCL
 - ii. L-1
 - iii. L-1/2
 - iv. OO
 - v. R-1/2
 - vi. R-1
 - vii. LCR
 - h. Score:
3. Name:
- a. Trial 1: Choice of Path:
 - i. LCL
 - ii. L-1
 - iii. L-1/2
 - iv. OO
 - v. R-1/2
 - vi. R-1
 - vii. LCR
 - b. Score:
 - c. Trial 2: Choice of Path:
 - i. LCL
 - ii. L-1
 - iii. L-1/2
 - iv. OO
 - v. R-1/2
 - vi. R-1
 - vii. LCR
 - d. Score:

e. Trial 3: Choice of Path:

- i. LCL
- ii. L-1
- iii. L-1/2
- iv. OO
- v. R-1/2
- vi. R-1
- vii. LCR

f. Score:

g. Trial 4: Choice of Path:

- i. LCL
- ii. L-1
- iii. L-1/2
- iv. OO
- v. R-1/2
- vi. R-1
- vii. LCR

h. Score:

Checklist for Identification of Highway Changes

Observer or Driver Instructions

In advance of each block (in an urban district) or given segment of roadway (in rural district), use commentary driving to identify areas of less space to the sides, less visibility, and less traction. When there is time, "view" column stands for view to the sides. The "sight" column stands for sight distance ahead.

Recorder Instructions

Put an "X" in the proper column for the item selected. Then, after checking with your teacher or other students score (C) for correct and (check) for incorrect

1. Name:
2. Trial 1:
 - a. Visibility
 - i. Sight
 1. Yes
 2. No
 - ii. View
 1. Yes
 2. No
 - b. Space changes
 - i. Less
 - ii. More
 - iii. Same
 - c. Traction changes
 - i. Less
 - ii. More
 - iii. Same
 - d. Score:
3. Trial 2:
 - a. Visibility
 - i. Sight
 1. Yes
 2. No
 - ii. View
 1. Yes
 2. No

- b. Space changes
 - i. Less
 - ii. More
 - iii. Same
 - c. Traction changes
 - i. Less
 - ii. More
 - iii. Same
 - d. Score:
4. Trial 3:
- a. Visibility
 - i. Sight
 - 1. Yes
 - 2. No
 - ii. View
 - 1. Yes
 - 2. No
 - b. Space changes
 - i. Less
 - ii. More
 - iii. Same
 - c. Traction changes
 - i. Less
 - ii. More
 - iii. Same
 - d. Score:
5. Trial 4:
- a. Visibility
 - i. Sight
 - 1. Yes
 - 2. No
 - ii. View
 - 1. Yes
 - 2. No
 - b. Space changes
 - i. Less
 - ii. More
 - iii. Same

- c. Traction changes
 - i. Less
 - ii. More
 - iii. Same
 - d. Score:
6. Trial 5:
- a. Visibility
 - i. Sight
 - 1. Yes
 - 2. No
 - ii. View
 - 1. Yes
 - 2. No
 - b. Space changes
 - i. Less
 - ii. More
 - iii. Same
 - c. Traction changes
 - i. Less
 - ii. More
 - iii. Same
7. Score:
8. Name:
9. Trial 1:
- a. Visibility
 - i. Sight
 - 1. Yes
 - 2. No
 - ii. View
 - 1. Yes
 - 2. No
 - b. Space changes
 - i. Less
 - ii. More
 - iii. Same
 - c. Traction changes
 - i. Less
 - ii. More
 - iii. Same
 - d. Score:

10. Trial 2:

- a. Visibility
 - i. Sight
 - 1. Yes
 - 2. No
 - ii. View
 - 1. Yes
 - 2. No
- b. Space changes
 - i. Less
 - ii. More
 - iii. Same
- c. Traction changes
 - i. Less
 - ii. More
 - iii. Same
- d. Score:

11. Trial 3:

- a. Visibility
 - i. Sight
 - 1. Yes
 - 2. No
 - ii. View
 - 1. Yes
 - 2. No
- b. Space changes
 - i. Less
 - ii. More
 - iii. Same
- c. Traction changes
 - i. Less
 - ii. More
 - iii. Same
- d. Score:

12. Trial 4:

- a. Visibility
 - i. Sight
 - 1. Yes
 - 2. No

- ii. View
 - 1. Yes
 - 2. No

b. Space changes

- i. Less
- ii. More
- iii. Same

c. Traction changes

- i. Less
- ii. More
- iii. Same

d. Score:

13. Trial 5:

a. Visibility

- i. Sight
 - 1. Yes
 - 2. No

- ii. View
 - 1. Yes
 - 2. No

b. Space changes

- i. Less
- ii. More
- iii. Same

c. Traction changes

- i. Less
- ii. More
- iii. Same

d. Score:

14. Name:

15. Trial 1:

a. Visibility

- i. Sight
 - 1. Yes
 - 2. No

- ii. View
 - 1. Yes
 - 2. No

- b. Space changes
 - i. Less
 - ii. More
 - iii. Same
 - c. Traction changes
 - i. Less
 - ii. More
 - iii. Same
 - d. Score:
16. Trial 2:
- a. Visibility
 - i. Sight
 - 1. Yes
 - 2. No
 - ii. View
 - 1. Yes
 - 2. No
 - b. Space changes
 - i. Less
 - ii. More
 - iii. Same
 - c. Traction changes
 - i. Less
 - ii. More
 - iii. Same
 - d. Score:
17. Trial 3:
- a. Visibility
 - i. Sight
 - 1. Yes
 - 2. No
 - ii. View
 - 1. Yes
 - 2. No
 - b. Space changes
 - i. Less
 - ii. More
 - iii. Same

- c. Traction changes
 - i. Less
 - ii. More
 - iii. Same
 - d. Score:
18. Trial 4:
- a. Visibility
 - i. Sight
 - 1. Yes
 - 2. No
 - ii. View
 - 1. Yes
 - 2. No
 - b. Space changes
 - i. Less
 - ii. More
 - iii. Same
 - c. Traction changes
 - i. Less
 - ii. More
 - iii. Same
 - d. Score:
19. Trial 5:
- a. Visibility
 - i. Sight
 - 1. Yes
 - 2. No
 - ii. View
 - 1. Yes
 - 2. No
 - b. Space changes
 - i. Less
 - ii. More
 - iii. Same
 - c. Traction changes
 - i. Less
 - ii. More
 - iii. Same
 - d. Score:

Appendix D

Commentary Driving

Commentary Driving, Tell It Like You See It

You have been given some ways to improve your perceptual skills for driving. Now, you will want to try these out in the car. The best way to do this is to use commentary driving with a classmate, relative, or a friend.

Commentary driving is a method for checking out how well a driver or passenger can identify all the events and clues. It consists of making comments about what you see in the traffic scene around you while driving or riding in a vehicle. In other words, it is simply a reading aloud of the traffic picture as it unfolds around you. Once you practice this method a few times, you will find it interesting and helpful

This method will be helpful, because it will force you to identify things quickly and well ahead of your car. You will then have a better idea as to whether you are seeing events in time to take proper action. It also gives you a chance to compare your observations with those of others. Are you really developing selective seeing habits? Another benefit of commentary driving is that it will help you judge the speed that is proper for conditions.

When using commentary driving, you should try to describe everything that could affect your path of travel. This includes what you see ahead, to both sides, and in your rear-view mirrors. Your general pattern of comments should be related to such questions as, "What is it?", "Where is it?", and "What is it doing?" If its condition is important, then include that in your comments.

Try making your comments as specific and brief as possible. Use short phrases or just a few words as possible. You may wish to use such terms as entering car, exiting car, following car, intersecting car, merging car, oncoming car, ongoing car, parking car, passing car, and turning truck.

Since proper timing of vehicle movement is one of the keys of safe driving, you will need to make comments about events taking place well ahead of your car. Otherwise, the method will be of little value to you. Since you can't identify and comment on everything you observe, comment first on what you think could be most likely to affect your intended path of travel

It is best to begin with one group at a time, as we did with the slides. For TRAFFIC CONTROLS, you might make such comments as "Open intersection... Speed limit 35... My speed is 40... Signal light is stale green... Walk light just flashed off... My lane must turn left... No turn on red... Must yield to van... No passing zone... On a state highway."

Here are some examples for HIGHWAY CONDITIONS: "Curve is flat... No shoulder... Rough pavement in front of motorcyclist... Blind intersection... Less space... Gravel on pavement... Divided highway ends."

Comments on OTHER USER clues may include phrases such as: "Following car is tailgating... Truck is about to pass... Parked car is backing... No eye contact with child bicyclist... Oncoming car drifting toward center... Pedestrian off-curb... Car closing from right... Van may not complete turn."

After some practice with each group, try a running commentary on all groups.

Comments can then evolve into statements such as: "Ongoing car OK... Parked cars on left OK... Pedestrians OK... Intersecting car OK... No changes in roadway." In urban areas, you can merely indicate at the beginning of each block whether the intended path is clear or not clear. These statements indicate that all the various clues have been checked out, and there is no evidence for a closing moment within the 12 second pathway.

When you are on an extended trip with your family, and after a demonstration, ask other members to take turns seeing how perceptive they are. Also, a person in the back seat may be asked to watch the rear-view mirror to check out how often the driver moves his or her eyes to check the mirrors and dash.

Good luck!

About Habit Formation

Good habits are hard to acquire but easy to live with.

Bad habits are easy to acquire but hard to live with.

When you choose a habit, you also choose its end result.

The best way to change a habit is to replace it with a new one.

Module IV—Other Classroom Units

Classroom Units of Instruction

Introduction

Other than the two previously identified classroom modules, the Decision-Making Module and the Perception and Driving Strategies for Different Environments, there are ten additional writs of instruction that can be taught in the classroom. These ten writs are presented differently from the other two modules because, as teachers, many of you are familiar with them and have been teaching them. The following format was used in developing the writs for this Guide.

1. Episode Justification
 - a. This is a brief description of why the writ should be taught to the new and inexperienced driver. You can add to the brief description to further justify the writ.
2. Episode Objectives
 - a. These are the overall objectives for the writ. They are brief and to the point and the Performance Objectives will detail how each of the Episode Objectives are met or accomplished.
3. Performance Objectives
 - a. These are measurable objectives for the teachers to know what to teach and for the students to know what to learn and how to demonstrate their performance. The numbering of the Performance Objectives relate to each Episode Objective. Teachers should feel free to add to these objectives as they see a need to address specific needs of the students.
4. Content
 - a. This is a brief outline for each Performance Objective which should not be considered all inclusive. The Content is designed to give the teachers direction so they can expand on the information. Teachers need to be knowledgeable and competent with each performance objective.
5. Resources
 - a. These are selected resources that relate to each unit. Once again, these are not all inclusive for each writ. As teachers, these will give you a start to familiarize yourself for the respective writs and then add to this list.

The thought and planning behind this part of the Curriculum Guide was to put together the necessary information that would enable teachers to develop comprehensive lesson plans for the respective writs. The one thing missing from this part of the Guide are Learning Activities, other than the suggested Decision-Making Case Studies for certain writs. The Learning Activities for these classroom writs are the teachers' responsibility, and they should depend upon many different variables.

The units are also not put in any particular order. It is the teachers' responsibility to teach them in a progression that they feel compliments the other two classroom modules and when they are most appropriate to the students' needs. Listed are some variables that might help in coordinating the different classroom modules and units.

1. If the students are taking the classroom phase of instruction as they are about to apply for or already have their learners' permits, then the classroom sessions should be addressing what they need to know or want to know when they are practicing on their permits, e.g., Decision-Making Model, Responsibilities When Entering Pennsylvania's Driver Licensing System, Man Made Laws, Perceptual Driving Program, etc.
2. If the students are taking the classroom phase of instruction well before they are eligible for their learner's permits, then first address those phases of instruction that they can relate to as users of the highway system but not necessarily as drivers. Save those phases of instruction that relate to the safe and efficient use of the motor vehicle as drivers towards the latter part of the classroom sessions.

Some of the units of instruction should be coordinated with other units of instruction. Some examples where this should be done are:

1. Incorporating the unit of Man Made Laws with the Perceptual Driving Program's Session Two, Identifying Traffic Controls;
2. Incorporating the unit of Adverse Conditions with the Night Driving Program in the Perception and Driving Strategies for Different Environments; and
3. Combining the unit of Natural Laws In Relation to Driving a Motor Vehicle with the unit on Adverse Conditions.

It is most appropriate to coordinate instruction as shown, because it will possess greater meaning and understanding for the students.

The number of contact hours that you have with your students should determine what units you teach and the length of time you spend with each unit. Certain units should have a higher priority than others, and as a teacher you must look at those units and their respective performance objectives and ask yourself this question, "What performance objectives are critical for the safety of the new driver, and what performance objectives are critical that you teach, because if you don't, the students will not have a chance to learn these from anyone else?" Remember what was identified in the initial Introduction to the Curriculum Guide and then prepare for your Planned Progression of Teaching and Learning.

Responsibilities when entering Pennsylvania's Driver Licensing System

Episode Justification

When a person desires to become a licensed driver in his/her respective state, he/she is assuming a great deal of responsibility. Driving is a "privilege" and not a "right;" and in order to maintain this "privilege," the new driver is expected to possess and demonstrate certain knowledge, skills and socially accepted behavioral patterns. All of the information regarding the

new driver's responsibilities is readily available, and it is his/her responsibility to obtain, understand and practice what is required.

Episode Objectives

1. The three components that comprise the Highway Transportation System.
2. The three skills that make up the driving task.
3. The administrative laws that regulate the licensing of drivers in Pennsylvania
4. The consequences of not abiding by the laws as established in the Pennsylvania Vehicle Code.

Performance Objectives

The student will:

- 1.1. Identify the three components that make up the Highway Transportation System;
- 1.2. Identify and explain the diversity that exists in the highway component;
- 1.3. Identify and describe the diversity that exists in the people component;
- 1.4. Identify and describe the diversity that exists in the vehicle component;
- 1.5. Define the overall goal of the Highway Transportation System;
- 1.6. Describe the enforcement responsibility in the total Highway Transportation System;
- 2.1. Identify the physical skills needed to perform the driving task;
- 2.2. Identify the mental skills needed to perform the driving task;
- 2.3. Identify the social skills needed to perform the driving task;
- 3.1. Identify the age requirement for obtaining a learner's permit;
- 3.2. List and describe the documents that are used as proof of age;
- 3.3. Identify other documents and requirements for securing a learner's permit;
- 3.4. Describe why driving is a "privilege" and not a "right" and how this "privilege" might be terminated;
- 3.5. Identify the driver's responsibilities when driving with a learner's permit;
- 3.6. Identify the driver's responsibilities when driving with a junior license;
- 3.7. List the requirements for taking the license exam;
- 4.1. Explain the purpose of the Pennsylvania Uniform Vehicle Code and how it regulates the Highway Transportation System;
- 4.2. Describe Pennsylvania's current Point System and its importance in regulating the Highway Transportation System;
- 4.3. Identify the legal consequences associated with failure to comply with the laws of Pennsylvania's Vehicle Code; and
- 4.4. Describe the moral obligations associated with abiding by the laws of Pennsylvania's Vehicle Code.

Content

1. The Highway Transportation System is made up of highways, people and vehicles.
2. The student will be introduced to the concept that the highways have a diverse make-up from width, surface, speed, markings and other conditions.
 - a. Roadway Types - There are various types of road/lane configurations which present the driver with various situations. Drivers must recognize the potential hazards and adapt their driving to suit the conditions present. The following are examples:
 - i. Single-lane roads, public or private, and various surfaces;
 - ii. Two-lane, two-way roads which are the common types of roads;
 - iii. Multiple-lane roadways;
 - iv. Roadways that have controls and those that are uncontrolled;
 - v. Rural, urban or interstate highways;
 - vi. Congested or low volume roads; and
 - vii. One-way roads.
 - b. Roadway Makeup- The surface makeup, design and maintenance level of the road can contribute to the driver's ability to control a vehicle. Various surfaces can present the driver with selective situations. Drivers must recognize the hazards and adapt their driving to suit the conditions that are present. The following are examples:
 - i. Surface Types
 1. Concrete
 2. Asphalt
 3. Gravel
 4. Dirt
 - ii. Design Types
 1. Level
 2. Banked
 3. Crowned
 - iii. Maintenance Levels
 1. Winter care
 2. Regular care
 3. Long-term improvements
 - c. Roadway Speeds - Posted speed limits indicate the maximum safe driving speed when driving under ideal conditions. When the road is slippery or anything less than perfect, the driver must drive below the posted speed limit. When deciding how far below the posted speed limit you should drive, you must consider space, visibility and traction problems.
 - i. Rural limits- (35-55 mph) hills, curves and animals;
 - ii. Residential limits- (25-35 mph) pedestrians, children, animals and cars;
 - iii. City, town, business limits- (25-35 mph) pedestrians, construction, stop and go traffic;

- iv. Expressway, interstate limits- (55-65 mph) vehicle sizes, space and visibility; and
- v. School speed zones- (15 mph)
- d. Roadway Conditions- Roadway conditions constantly change. The conditions influence the safe speed and path of travel. The following are examples:
 - i. Traction problems - seasonal problems and surface conditions.
 - ii. Vision problems - weather and geographical problems.
 - iii. Space problems - geographical, construction and other users.
- e. Traffic Controls- Traffic controls regulate the flow of traffic. Students must become familiar with the location and meaning of the controls. The following an example:
 - i. Traffic signs
 - 1. Regulatory
 - 2. Warning
 - 3. Guide
 - ii. Traffic signals
 - iii. Pavement markings
 - 1. White lines - solid or broken
 - 2. Yellow lines - solid or broken
 - 3. Arrows
 - 4. Stop lines
- f. Shoulder or Berm- Portion of highway adjacent to the roadway that should only be used for emergency purposes, e.g., mechanical problem, alternate path of travel (escape path). Space and traction need to be identified and evaluated by drivers.
- g. Median - Portion of highway that separates roadways going opposite direction. This can vary in width and traction and should be identified and evaluated by driver.
- 3. The student will be introduced to the concept of how diversity among the various drivers make driving an ever-changing event.
 - a. Driver Age - As a driver on the road, one must expect minimum standards of ability. As drivers go from young and inexperienced towards becoming elderly, driving abilities change. Not all drivers are created equal!
 - i. Minimum age requirements from state to state
 - 1. Some states have permit ages as low as 14 years
 - 2. New York City requires a permit driver to be 17 years old
 - ii. Maximum age limits or when the license will be surrendered
 - 1. No state has a mandatory surrender age
 - 2. Physical disability usually causes disqualification
 - b. Driver Experience - The more experience the driver has, the more likely he will respond to a situation correctly.
 - i. Driver knowledge
 - ii. Driver judgment
 - iii. Familiarity of area to drivers

- c. Other Users of the Roadway- Because the other users of the roadway cannot be directly controlled, drivers must be able to identify and predict their behavior in order to drive safely.
 - i. Other vehicles
 - ii. Other drivers
 - iii. Pedestrians
 - iv. Bicycles
 - v. Animals
 - d. Driver Distractions- The driver must be able to separate actions that are important to the driving task. The following are some examples to support the objective.
 - i. Other passengers
 - ii. Mental and physical condition of the driver
 - iii. Emotional conditions
 - iv. Stereo, CD, cell phones...
4. The student will be introduced to the diversity that exists with the various motor vehicles permitted to be used on our highways.
- a. Condition of the Vehicle - When a driver chooses a vehicle, he/she should look for vehicles that meet his/her driving needs as well as safety and reliability. The following are some examples to support the objective:
 - i. Safety and Crashworthiness- will the vehicle protect the occupants?
 - ii. Reliability - will the vehicle continue to operate for an extended period of time without major repairs?
 - b. Size and Function of the Vehicle- How are you going to use the vehicle? Will it handle your driving style? Not all vehicles meet everyone's needs! The following are some examples to support the objective:
 - i. Small vehicles - motorized/non-motorized, motorcycles, bicycles, small cars - less protection but better fuel usage.
 - ii. Medium vehicles- sedans and mid-size vans and pickup trucks -better fuel usage, better protection.
 - iii. Large vehicles- Sport utility vehicles, large pickup trucks- poor gas mileage, roll-over factors- can move large numbers of people or cargo.
 - iv. XL vehicles- tractor trailers, buses- poor maneuverability, poor gas mileage.
5. The overall goal of the (HTS) Highway Transportation System is to provide for the safe and efficient transportation of both people and goods from one point to another point.
6. The student will be introduced to the regulatory factors of the HTS - local police, state police and courts. The following are examples:
- a. Federal Mandates - The government sets national standards or regulations for motor vehicle manufacturers and state highway laws.
 - i. Speed limits
 - ii. Alcohol and driving
 - iii. Occupant restraints
 - iv. Safety requirements in vehicles

- b. State laws- States control their highways and enact laws for both the vehicles and drivers. The following are some examples that support the objective:
 - i. Vehicle code
 - ii. Licensing laws
 - iii. Road development and maintenance
 - iv. Enforcement of the law
 - v. Courts
 - c. Local - Local government and law enforcement follow mandates to make their area safe. The following are some examples that support the objective:
 - i. Maintenance of the local roads
 - ii. Local ordinances
 - iii. Enforcement of laws
 - iv. Courts
7. The student will be introduced to the physical skills needed to perform the driving task
- a. Vision - The following are some examples:
 - i. Minimum visual standards; and
 - ii. Vision can be distorted by illness, light, dark, and glare.
 - b. Physical Disabilities - The following are some examples:
 - i. Minimum physical standards
 - 1. Sight
 - 2. Appendage use - cars can be adapted for many disabilities
 - 3. Seizures, diabetes, heart conditions
 - ii. Medications - The following are some examples that can be used to support the objective:
 - 1. Over-the-counter medications can affect driving in many ways, depending upon the medication.
 - 2. Prescription medications can affect driving in many ways, depending upon the contents of the medications.
8. The student will be introduced to the mental skills needed to perform the driving task.
- a. Understanding of the Laws- The following are some examples:
 - i. Traffic controls
 - ii. Vehicle code
 - b. Understanding of Roadway Conditions- The following are some examples:
 - i. Roadway design
 - ii. Roadway traction
 - iii. Roadway space
 - iv. Roadway visibility
 - c. Understanding of the Needs· and Actions of Other Users of the Highway: The following are some examples:
 - i. Pedestrians
 - ii. Bicyclists
 - iii. Large vehicles
 - iv. Special vehicles
 - v. Emotional factors that take away from the driving task

9. The student will be introduced to the social skills needed to become a competent driver.
 - a. Cooperating with Other Highway Users- The following are some examples of where it is important to be cooperative:
 - i. In heavy traffic
 - ii. In construction zones
 - iii. At intersections
 - b. Predictability of Your Actions- The following are some examples:
 - i. Obeying traffic laws
 - ii. Giving ample warning of your intentions
 - c. Patience with Self and Others - The following are some examples:
 - i. Allowing enough following distance
 - ii. Allowing enough time to get to your destination
 - iii. Being forgiving of others' mistakes
 - iv. Observing the other driver's condition - age, emotions, experience level, lost (out-of-state license plate)

Information for Performance Objectives 3.1 to 4.4 is obtainable from the Pennsylvania Uniform Vehicle Code and the Pennsylvania Driver's Manual. You need both of these resources to stay up-to-date on all changes that periodically occur with legislation.

Resources

1. Textbooks

- a. Drive Right
- b. How to Drive
- c. Responsible Driving
- d. License to Drive

2. References

- a. Vehicle Laws of Pennsylvania, Title 75 (current)
- b. Pennsylvania Driver's Manual (current)
- c. Pennsylvania Crash Facts and Statistics (current)
- d. AAA Digest of Motor Laws (current)
- e. www.hwysafety.org

3. Case Study

Decision-Making Exercise for Entering the System

Situation

You and four of your good friends have been out most of the afternoon cruising around in your car. It is a lot of fun because you just recently received your license and your parents have given you a car of your own.

At the end of the afternoon all of you go back to your house for a picnic dinner and an evening of socializing - goofing off as usual; just having fun being teenagers.

It is now 10 p.m. and you must take all of your friend's home and be back by 11 p.m. Everyone climbs into your car for the trip through the various developments. As you are driving through your development, your 15-year-old friend asks if she can drive the car in your development. You know that she is 15 years old and an illegal driver. It is late at night and there is never much traffic in your development. As you are thinking about what your answer will be, your friend asks you the same question over and over. Do you let her drive the car?

How to Use the Decision-Making Model

1. Put students in groups.
2. Read the situation to the groups.
3. Have each group come up with the answer to the situation and explain why they feel their answer is a good answer.
4. Go back over the Decision-Making Model to review how to make a decision.
5. Have each group justify their answer using the model.
6. Have the groups share their answers with the entire class.
7. Read some newspaper articles to the class to show the devastating results of poor decision-making.

Some examples of answers that may be presented by the students:

Stop

1. Unlicensed driver wants to drive your car
2. An illegal act
3. You may lose a friend by saying no
4. Parents would be very upset with you if you let her drive
5. Could hurt yourself and others
6. How could you get caught?

Think

1. Right/wrong
 - a. Illegal action
 - b. Not hurting anyone -has to practice sometime
 - c. Could hurt someone
2. Reality
 - a. Others do it all of the time and nothing happens
 - b. There isn't much traffic to interact with
 - c. It is a safe area
 - d. It is illegal
 - e. Parents will "ground" you if they ever found out
3. Responsibility
 - a. It is illegal
 - b. Your parents trust you to be responsible
 - c. You will be responsible (liable) for anything that happens and so on.

Decision-Making Exercise for Entering the System

Situation

You and your 17-year-old brother are on the high school football team and have practice every day after school.

You have just turned 16 last month and have your permit but have not driven on any main roads as of yet just on rural roads around your house.

It is a Thursday afternoon and you and your brother are at football practice and your brother hurts his leg and has pain and discomfort and cannot drive safely and properly to get both of you home.

You call home for you parents, so they can come for the two of you, but there is no answer and then you remember your parents told you in the morning they were going away and would not be home until late.

You have no other way to get home, so your brother suggests that you drive the both of you home since it is getting late.

What do you do?

Man-Made Laws

Episode Justification

Since driving a motor vehicle involves the sharing of the roadway with other highway users, there must be a written set of rules and regulations that establish guidelines for the safe and efficient use of the highway transportation system. The set of rules and regulations all highway users are expected to know and practice in Pennsylvania are in the Pennsylvania Vehicle Code. Statistics tell us that young drivers are involved in a disproportionate number of highway collisions and that 43 percent of their collisions occur at intersections. Another contributing cause of collisions for young drivers is excessive speed. These and other contributing causes all have a foundation of not applying the traffic laws that the young driver either knows or does not know.

Episode Objectives

1. Obedience to and effect of traffic laws;
2. Rules of the road in general;
3. Motorcycles, Pedalcycles and Pedestrians; and
4. Miscellaneous provisions.

Performance Objectives

The student will:

- 1.1. List and describe the authorized persons who may direct and control traffic;
- 1.2. Explain the responsibilities when encountering a person riding an animal or encountering an animal-drawn vehicle;
- 1.3. Identify the responsibilities when encountering persons working on the highways;
- 1.4. Identify the various emergency vehicles that use the highway;
- 1.5. Explain the responsibilities when encountering an emergency vehicle running in the emergency mode;
- 1.6. Explain the responsibilities when encountering a funeral procession;
- 1.7. Explain the driver's responsibilities and pedestrian's responsibilities when encountering the selective lights at a traffic control signal;
- 1.8. Identify and explain the various pedestrian-control signals;
- 1.9. Identify the two flashing signals and the driver's responsibilities with the two signals;
- 1.10. Identify the meaning of selective lane-direction control signals;
- 2.1. Identify the exceptions to driving on the right side of the roadway;
- 2.2. Explain the responsibilities of meeting a vehicle proceeding in the opposite direction;
- 2.3. Explain the responsibilities associated with overtaking another vehicle and passing on the left;
- 2.4. Explain the situations where one is allowed to overtake and pass another vehicle on the right;
- 2.5. Identify lane selection on multiple-lane roadways;
- 2.6. Explain the responsibilities associated with using divided highways;

- 2.7. Explain the responsibilities of using limited access highways;
- 2.8. Explain the general rule of following another vehicle;
- 2.9. Explain the prohibition of using hearing impairment devices;
- 2.10. Explain the right-of-way for a vehicle approaching or entering an intersection;
- 2.11. Describe the responsibilities when turning left;
- 2.12. Describe the responsibilities of using an intersection controlled by a stop sign and a yield sign;
- 2.13. Explain the responsibilities when entering or crossing a roadway from anywhere other than another roadway;
- 2.14. Identify the limitations of performing a turn-about;
- 2.15. Explain the turning movements and required signals for each;
- 2.16. Describe the responsibilities of crossing a railroad grade crossing;
- 2.17. Explain the responsibilities when emerging from an alley, driveway or building;
- 2.18. Describe the responsibilities of meeting or overtaking a school bus;
- 2.19. Define the term "driving a vehicle at a safe speed;"
- 2.20. Explain maximum speed limits;
- 2.21. Explain minimum speed regulation;
- 2.22. Explain special speed limitations in a school zone;
- 3.1. Identify the driver's responsibilities when encountering pedalcyclists;
- 3.2. Identify the driver's responsibilities when encountering motorcyclists;
- 3.3. Explain the responsibilities when encountering pedestrians;
- 4.1. Describe the law of not leaving an unattended child in a motor vehicle;
- 4.2. Explain the limitations of backing a motor vehicle;
- 4.3. Explain the prohibition of depositing waste and other material on highway, property or water;
- 4.4. Identify the serious traffic offenses;
- 4.5. Explain the responsibilities if involved in a collision;
- 4.6. Explain the responsibilities if involved in a collision with an unattended vehicle or property; and
- 4.7. Explain the responsibilities when coming first on the scene of an accident.

Content

- 1. Authorized persons who may direct and control traffic are:
 - a. Uniformed police officer, sheriff or constable.
 - b. In certain emergencies, a railroad or street railway police officer; or any appropriately attired person, including an agent or employee of the funeral director during a funeral. Drivers shall willfully comply with any lawful order or direction of the authorized persons.
- 2. The driver's responsibilities when encountering a person riding an animal or animal-drawn vehicle upon a roadway shall be the same as if the person was driving a motor vehicle. A person riding an animal or driving an animal-drawn vehicle would not be permitted to use a limited access highway.

3. The duties of the driver when encountering person(s) working on the highway are to yield the right-of-way to any authorized vehicle or pedestrian engaged in work on the designated section of the highway.
4. The various emergency vehicles that are permitted to use the highways are:
 - a. Fire Department vehicle.
 - b. Police vehicle.
 - c. Sheriff vehicle.
 - d. Ambulance.
 - e. Blood Delivery vehicle and Organ Donor Delivery vehicle.
 - f. Hazardous Material Response vehicle.
 - g. Armed Forces Emergency vehicle.
 - h. A Coroner or Medical Examiner vehicle.
 - i. Any vehicle designated by the Pennsylvania State Police related to the fire, police and ambulance service.
5. The driver's responsibilities when encountering an emergency vehicle running in the emergency mode (lights and/or siren) would include:
 - a. Shall yield the right-of-way and move as far right on roadway as possible and stop until the emergency vehicle has passed.
 - b. If the driver is in an intersection, then the driver shall clear the intersection and pull to the right and stop until the emergency vehicle has passed.
6. A funeral procession is identified with lighted head lamps, emergency flashers and a flag or other insignia. Drivers encountering a funeral procession shall yield the right-of-way until all of the vehicles have passed.
7. Driver and pedestrian responsibilities at traffic control signals are:
 - a. Steady green indication
 - i. Vehicles facing a green light may proceed straight, turn right or turn left unless such movement is prohibited. Entering an intersection on green, the driver shall yield to other vehicles or pedestrians lawfully in the intersection or crosswalk at the time the signal is exhibited.
 - ii. Vehicles facing a green arrow can proceed in that direction but shall yield to pedestrians or vehicles already lawfully using the intersection.
 - iii. Pedestrians facing a green signal without pedestrian control signals may proceed across the roadway within the crosswalk.
 - b. Steady yellow indication
 - i. Vehicles facing a steady yellow signal are warned that the green is terminated, and the red will be exhibited. Drivers who have not yet entered the intersection should stop and drivers already in the intersection should clear. Do not speed up to clear the intersection on a yellow light.
 - ii. Pedestrians facing a steady yellow light should not begin to cross and if they are already in the crosswalk, they should clear as soon as possible.

- c. Steady red indication
 - i. Vehicles facing a steady red light shall stop at a stop line, pedestrian crosswalk, or intersecting roadway if neither a stop line or pedestrian crosswalk are present.
 - ii. Unless a sign is present prohibiting a right or left turn (from one-way onto a one-way street) on red, then the- driver shall stop at the designated stops and may proceed when safe to do so.
 - iii. Pedestrians facing only a steady red light shall not enter the roadway.
8. The special pedestrian control signals include:
 - a. The word "Walk" or symbol of a walking person - the pedestrian should cross in the respective direction and shall be given the right-of-way by drivers of motor vehicles.
 - b. The words "Don't Walk" or symbol of upraised hand- the pedestrian should not start across in the respective direction; and if already in the crosswalk, continue to a sidewalk or safety zone.
 - c. Flashing "Walk" - the pedestrian should cross in the respective direction but be cautious of turning vehicles. The drivers of motor vehicles shall yield the right-of-way to pedestrians in the crosswalk.
 - d. Flashing "Don't Walk"- the pedestrian should not start to cross the roadway, but if already in the crosswalk, then continue to cross to sidewalk or safety zone. This signal is the prelude to the steady "Don't Walk."
 9. The two flashing signals that drivers of motor vehicles encounter are:
 - a. Flashing red- a driver facing a flashing red signal must stop in the same manner as at a stop sign and then proceed when it is safe.
 - b. Flashing yellow- a driver facing a flashing yellow signal may proceed through the intersection or past the signal only with caution.
 10. Special lane -directional - control signals are placed over individual lanes on the roadway and vehicular traffic may travel in any lane over which the green signal is shown but shall not enter or travel in any lane over which a red signal is shown.
 11. A vehicle shall be driven upon the right half of the roadway except as follows:
 - a. When overtaking, and passing another vehicle proceeding in the same direction where permitted.
 - b. When an obstruction exists, but only after yielding to other traffic.
 - c. Where official traffic control devices direct traffic to the left of center.
 - d. A one-way roadway.
 - e. When making a left turn.
 12. When meeting another vehicle proceeding in the opposite direction, the drivers shall give at least one-half of the roadway to the other vehicle.
 13. When overtaking and passing another vehicle proceeding in the same direction in a legal passing zone, the following rules shall govern this action:
 - a. The passing driver shall pass to the left of the other vehicle at a safe distance and shall stay to the left of the other vehicle until safely clear of the passed vehicle.

- b. The driver of an overtaken vehicle shall not increase the speed of his vehicle until completely passed by another vehicle.
 - c. The passing driver shall use the respective turn signal when moving to the passing lane and back to the right lane.
 - d. When needed, the passing driver shall use a suitable signal which at certain times could be headlights and other times, the horn.
14. The driver of a vehicle may overtake and pass on the right of another vehicle only under one of the following conditions:
- a. When the vehicle overtaken is making or about to make a left turn, except that such movement shall not be made by driving off the berm or shoulder of the highway.
 - b. Upon a roadway with unobstructed pavement of sufficient width for two or more lanes of vehicles moving lawfully in the direction being traveled by the overtaken vehicle, except that such movement shall not be made by driving off the roadway.
 - c. No passing movement shall be made to the right unless the movement can be made safely.
15. Lane selection on multiple lane roadways would involve the following actions:
- a. Far right lane- merging and exiting on right, turning right, parking on right, slower traffic.
 - b. Far left lane- merging and exiting on left, turning left, passing, through traffic.
 - c. Center lane- through traffic, passing, roadway divides.
16. Responsibilities associated with driving on a divided highway include:
- a. Every vehicle shall be driven on the right-side roadway to the right of the physical barrier unless directed by a traffic control device or person.
 - b. No vehicles shall be driven across the divided highway or through an opening in the barrier unless directed to do so.
17. Limited access highways control where vehicles can enter and exit. They also regulate the various highway users who can and cannot use the respective highways.
18. The general rule for following another vehicle is the driver shall not follow another vehicle more closely than is reasonable and prudent, having due regard for the speed of the vehicles and the traffic upon and the condition of the highway.
19. No driver shall operate a vehicle while wearing or using one or more headphones or earphones. There are exceptions to this as noted in section 3314 of the Vehicle Code.
20. When two vehicles approach or enter an intersection from different highways at approximately the same time, the driver of the vehicle on the left shall yield the right-of-way to the vehicle on the right, except in the following circumstances.
- a. On through highways, the traffic on the through highway shall have the right-of-way.
 - b. On limited access highways, the traffic on the limited access highway shall have the right-of-way.
 - c. In traffic circles, the traffic in the traffic circle shall have the right-of-way.

21. The responsibilities of a driver intending to turn left shall be to yield the right-of-way to any vehicle approaching from the opposite direction which is so close as to constitute a hazard.
22. The responsibilities of a driver at an intersection controlled by a stop sign are:
 - a. Stop at a clearly marked stop line or, if none, before entering a crosswalk or, if none, then at the intersecting roadways.
 - b. After stopping, the driver shall yield the right-of-way to any pedestrian in a crosswalk or to any vehicle at the intersection or approaching the intersection.
23. The responsibilities of a driver at an intersection controlled by a yield sign are:
 - a. Slow down to a speed reasonable for the existing conditions and, if required for safety to stop, shall stop before entering a crosswalk or, if none, at the intersecting roadways.
 - b. After slowing or stopping the driver shall yield the right-of-way to any vehicle in or approaching the intersection.
 - c. If a driver has a collision at an intersection marked by a yield sign, then they will be judged responsible for the collision.
24. When entering or crossing a roadway from anywhere other than another roadway, the driver shall yield the right-of-way to all vehicles approaching on the roadway to be entered or crossed.
25. The driver of a vehicle shall not turn the vehicle so as to proceed in the opposite direction unless the movement can be made safely and without interfering with other traffic. This action is not permitted in any area where there is less than 500 feet sight distance.
26. Required signals for the various movements are:
 - a. Turn signal is required when making a lane change.
 - b. Turn signal is required when entering or leaving the flow of traffic.
 - c. Turn signal is required for a left or right turn a minimum of 100 feet at less than 35 mph and a minimum of 300 feet in excess of 35 mph.
 - d. Turn signals shall be discontinued after completing the turn or movement.
27. When approaching a railroad crossing, the driver should slow and search for signs or clues of an approaching train. If required to stop, then the driver should stop within fifty feet but not less than fifteen feet from the nearest rail.
 - a. If the railroad crossing is controlled with lights and gates and both are activated, then the driver shall not start to drive around the gate.
 - b. If the railroad crossing is controlled with lights only and there is no visible or audible signal of an approaching train, then the driver after stopping and being certain there is no immediate train may proceed across the tracks.
 - c. If there are no lights or barriers but the visual or audible approach of a train, then the driver shall stop and only proceed if there is no immediate threat of the crossing train.
 - d. Drivers need to be aware of railroad crossings and always search for clues of an approaching train(s).

28. When emerging from an alley, driveway or building, the driver shall stop immediately prior to driving onto a sidewalk or sidewalk area extended, yield to pedestrians, and then yield to other traffic.
29. The duties of a driver when approaching a stopped school bus from either direction is to stop a minimum of ten feet from the stopped bus and stay stopped until the flashing red lights are canceled. If meeting a stopped school bus with flashing red lights on a divided highway going in the opposite direction, then the driver can proceed past the stopped school bus going in the opposite direction. When approaching a school bus with amber flashing lights, the driver may proceed past the bus with caution and shall be prepared to stop when the red signal lights are flashing.
30. The term "driving vehicle at safe speed" means that no person shall drive a vehicle at a speed greater than is reasonable and prudent under the conditions present, nor at a speed greater than will permit the driver to bring his vehicle to a stop within the assured clear distance ahead. Every person shall drive at a safe speed when:
 - a. Approaching and crossing intersections or railroad grade crossings.
 - b. Approaching and going around curves.
 - c. Approaching a hill crest.
 - d. Traveling narrow and winding roads.
 - e. Encountering pedestrians and other traffic.
 - f. Encountering poor weather and highway conditions.
31. Maximum speed limits are established for specific areas and no person shall drive a vehicle in excess of the maximum speed limits, but conditions can exist as identified in "driving vehicle at safe speed" which would require a lower speed. The following maximum limits exist:
 - a. 35 mph in any urban district.
 - b. 65 mph for all vehicles on interstate highways outside of urban areas and other controlled access highways designated by the department.
 - c. 55 mph in other location.
32. Minimum speed regulations are established to address the problem of slow moving vehicles that can impede the normal and reasonable movement of traffic on specified highways.
33. When passing an active school zone with official traffic control devices indicating the beginning and end of the zone, no person shall drive a vehicle at a speed greater than 15 mph.
34. A person riding a pedalcycle on a roadway shall be granted all of the rights and shall be subject to all of the duties applicable to the driver of a vehicle. Bicyclists are required to stay as far to the right of the travel lane as possible. No more than two bicyclists may ride side-by-side.
35. A person operating a motorcycle shall be granted all of the rights and shall be subject to all of the duties applicable to the driver of any other vehicle. A motorcyclist is entitled to the use of a full travel lane. No more than two motorcyclists may ride side-by-side.
36. Drivers' responsibilities to pedestrians include:
 - a. Shall yield the right-of-way to pedestrians crossing the roadway in a marked crosswalk or within an unmarked crosswalk at an intersection.

- b. No driver shall overtake and pass another vehicle that is stopped at a crosswalk at an intersection.
 - c. No driver shall drive a vehicle through or within a safety zone.
 - d. The driver shall yield to pedestrians on or within an extended sidewalk when emerging from an alley, building, private road or driveway.
 - e. The driver shall yield the right-of-way to any totally or partially blind pedestrian carrying a clearly visible white cane or accompanied by a guide dog.
37. A driver or person in charge of a motor vehicle may not permit a child under six years of age to remain unattended in the vehicle when the motor vehicle is out of the person's sight and conditions which can endanger the child.
38. No driver shall back a vehicle unless the movement can be made with safety and without interfering with other traffic and then only after yielding the right-of-way to moving traffic and pedestrians. Backing is prohibited on a divided highway including the shoulder.
39. No person shall throw or deposit, upon any highway or upon any other public or private property without the consent of the owner, or on the waters of the Commonwealth, from a vehicle, any waste paper, sweepings, ashes, household waste, glass, metal, refuse or rubbish or any dangerous or detrimental substance.
40. The serious traffic offenses in Pennsylvania that result in revoked or suspended license:
- a. Driving under the influence of alcohol or controlled substance;
 - b. Homicide by vehicle;
 - c. Fleeing or attempting to elude police officers;
 - d. Driving without lights to avoid identification or arrest;
 - e. Homicide by vehicle while driving under the influence;
 - f. Aggravated assault by vehicle while driving under the influence; and
 - g. Reckless driving.
41. The responsibilities of a driver involved in a collision resulting in injury or death of any person or damage to any vehicle or other property, which is driven or attended by any person, shall do the following:
- a. Immediately stop the vehicle at the scene or as close as possible to the scene and remain until all responsibilities are met.
 - b. Render reasonable assistance to any person injured.
 - c. Give name, address and the registration number of the vehicle being driven.
 - d. Upon request, exhibit the driver's license and information relating to financial responsibility.
 - e. Immediately, by the quickest means of communication, give notice to the nearest police department if there is injury or death, or damage to any vehicle involved that requires towing.
 - f. If a police officer does not investigate a collision, required to be investigated, then the driver shall submit a written report within five days of the collision, to the Department.
42. The responsibilities of a driver involved in a collision with an unattended vehicle or property shall:
- a. Immediately stop at the scene or as close as possible.

- b. Attempt to locate and notify the operator or owner of the damaged vehicle or property, name, address, information relating to financial responsibility and registration number of the vehicle being driven.
- c. If owner-operator cannot be found, then leave the above information in a conspicuous place.
- d. Without unnecessary delay, notify the nearest office of a duly authorized police department.

Resources

- I. Textbooks
 - a. Drive Right
 - b. How to Drive
 - c. Responsible Driving
 - d. License to Drive
- II. References
 - a. Vehicle Laws of Pennsylvania, Title 75 (current)
 - b. Pennsylvania Driver's Manual (current)
- III. Stop- Think & Go Decision-Making Case Study
 - a. You are a passenger in a car that is driven by one of your close friends and there are also two other classmates that are passengers. It is night time and you are traveling on a two-lane rural road that has a great many curves and hills. You notice that your friend is constantly exceeding the posted speed limit by 15 to 20 mph. This excessive speed does not appear to be a problem with the other two passengers. What action, if any, will you take?
 - b. You have accepted a ride in the car of one of your friends; and as you enter the car, you notice that your friend who is the driver, and two of your classmates who are also passengers are not wearing their safety belts. What action, if any, will you take?

Natural Laws in Relation to Driving a Motor Vehicle

Episode Justification

Most drivers and passengers who were seriously injured or killed in Pennsylvania collisions were not wearing their safety belts. Speed too fast for conditions contributes to 16 percent of all motor vehicle collisions. In Pennsylvania, the greatest contributing cause of fatal collisions is excessive speed. Not wearing a safety belt, excessive speed and other scenarios all relate to natural laws and how they affect the starting, stopping, and steering of the motor vehicle, as well as the ability to avoid serious injury and/or death in the event of a collision.

A motor vehicle collision can occur when rounding a curve at too great a speed. A rear end collision can occur if one does not allow for sufficient braking distance. A driver and/or an occupant of a motor vehicle can increase the threat of serious injury and/or death if he/she does not or incorrectly uses the safety belt.

New drivers need to be aware of the role that natural laws play in operating a motor vehicle; and also, how to apply this information.

Episode Objectives

1. The differences between man-made laws and natural laws;
2. The role of gravity when operating a motor vehicle;
3. The role of inertia when operating a motor vehicle;
4. The role of friction when operating a motor vehicle;
5. The role of force of impact when operating a motor vehicle; and
6. The role that perception, reaction, and braking distance play in total stopping distance.

Teaching Point: This unit and the Adverse Conditions unit are closely related, and both of these units are interrelated with Module III, Perception and Driving Strategies For Different Environments. Please take this into consideration when planning your curriculum.

Performance Objectives

The student will:

- 1.1. Identify man-made laws that are directly related to natural laws;
- 1.2. Identify natural laws that are directly related to driving a motor vehicle;
- 1.3. Illustrate examples where man-made laws can easily be broken without suffering the consequences, but not so with natural laws;
- 2.1. Describe driving situations that are negatively affected by gravity;
- 2.2. Describe driving situations that are positively affected by gravity;
- 2.3. Describe the term center of gravity and how it affects vehicle control;
- 2.4. Identify motor vehicles that have a high center of gravity and how control of these vehicles is affected;
- 2.5. Identify motor vehicles that have a low center of gravity and how handling of these vehicles is affected;

- 2.6. Demonstrate the ability to make the necessary adjustments to counteract the risks of a motor vehicle with a high center of gravity;
- 3.1. Demonstrate the understanding that all moving objects will move in a straight line unless acted on by another force;
- 3.2. Explain the effect of inertia when controlling a motor vehicle in a curve;
- 3.3. Explain the effect of inertia when braking a motor vehicle to a stop;
- 3.4. Explain the role that inertia plays in a motor vehicle collision;
- 3.5. Identify how inertia is affected by the various sizes of motor vehicles;
- 4.1. Define friction;
- 4.2. Identify the three types of friction that are associated with operating a motor vehicle;
- 4.3. Explain the need for properly maintained tires;
- 4.4. Explain the need for properly maintained brakes;
- 4.5. Identify the various types of skids that can occur in a motor vehicle;
- 4.6. Explain the various procedures to control the vehicle when encountering selective skids;
- 4.7. Explain "hydroplaning" and how to avoid it and/or respond if it does occur;
- 5.1. Define "force of impact;"
- 5.2. List and explain the factors that can vary the vehicle's force of impact in a collision;
- 5.3. Explain the relationship of vehicle speed and force of impact;
- 5.4. Explain how the weight of the vehicle will affect force of impact in a collision;
- 5.5. Explain how distance traveled after initial collision will affect force of impact;
- 5.6. Identify and describe the "passive" restraint systems and the "active" restraint systems in a motor vehicle;
- 5.7. Demonstrate the proper use of "passive" and "active" restraints, including child safety restraints;
- 5.8. Explain how the various restraint systems in a motor vehicle eliminate or lessen the "second collision;"
- 6.1. Identify and describe the three components that comprise total stopping distance;
- 6.2. Demonstrate the ability to show how far a vehicle travels in $\frac{3}{4}$ or .75 of a second;
- 6.3. Explain the difference between simple reaction time and complex reaction time;
- 6.4. Identify the vehicle and highway factors that will affect braking distance in a positive or negative manner;
- 6.5. Explain the four to six seconds stopping distance and its importance to collision-free driving; and
- 6.6. Demonstrate how to measure total stopping distance and explain the relationship of speed.

Content

1. The man-made laws directly related to natural laws are:
 - a. Posted Speed Limits- Laws of Motion and Energy
 - b. Occupant Restraint Laws- Laws of Motion and Energy
2. The natural laws directly related to driving a motor vehicle are the laws of motion and energy which include:
 - a. Force of Impact- force that results when one object hits another object.
 - b. Friction -resistance to motion between surfaces that touch.

- c. Gravity- force that pulls all objects to the center of the earth.
 - d. Inertia- property that a moving object has to keep moving in the same straight line or direction unless acted on by some other force and if the object is at rest, to stay at rest.
 - e. Momentum- tendency that a moving object has to keep moving.
 - f. Kinetic Energy- energy that is being used that exists in several different forms.
 - g. Potential Energy- stored energy.
3. A person can exceed the posted speed limit on a straight stretch of highway where there are no real or potential hazards and suffer no ill consequences other than a potential citation. To exceed a posted speed limit in a curve could result in losing control of the motor vehicle and possibly encountering a collision.
 4. Driving situations negatively affected by gravity are:
 - a. Downgrades will cause the vehicle to go faster and increase its braking distance.
 - b. A high center of gravity of a vehicle going too fast in a curve or a sharp turn could cause the driver to lose control.
 5. Driving situations positively affected by gravity are:
 - a. The braking distance of a vehicle on an upgrade will be significantly reduced.
 - b. A vehicle with a low center of gravity will give the driver better control in a curve or a sharp turn.
 6. The center of gravity is the point around which an object's weight is evenly distributed. The lower the center of gravity for a vehicle, the better control of the vehicle. The higher the center of gravity, the greater opportunity to lose control of the vehicle.
 7. Motor vehicles that have a high center of gravity would include but not be limited to:
 - a. Tractor trailers
 - b. Straight trucks
 - c. Buses
 - d. Vans
 - e. Pickup trucks
 - f. Sport Utility Vehicles
 - g. Cars with a car-top carrier

By raising the center of gravity, the vehicle becomes less stable in turns, curves, braking and acceleration.

8. Motor vehicles that have a low center of gravity would be the majority of the cars designed by the auto manufacturers.
9. Driving a motor vehicle with a high center of gravity requires the driver to drive at the posted speed when conditions allow it, to reduce speed to the recommended speed of the warning sign, and to avoid sudden and abrupt turning of the steering wheel.
10. Moving objects will always want to move in a straight line and this is inertia. The other force that enables us to control inertia is friction. Friction enables the driver to steer in the desired direction and also control the speed of the vehicle.
11. Friction must always remain the stronger force if the vehicle is to remain on the road. The importance of reducing speed prior to the curve will reduce inertia and thus allow for greater traction when steering through the curve.

12. The relationship of inertia and kinetic energy is significant since an increase in speed and weight impacts on the amount of energy that must be converted into heat when a vehicle is braked to a stop. Using a simple mathematical formula enables one to determine braking distance on a dry, level road surface for a standard car.

$$D (\text{Distance}) = (S (\text{Speed}) * .1(S))/2$$

Examples are:

- A. What is the braking distance at 20 mph?
 - a. $D = (20 * .1(20))/2 = 20 \text{ ft}$
- B. What is the braking distance at 40 mph?
 - a. $D = (40 * .1(40))/2 = 80 \text{ feet (4 times greater than 20 mph)}$
- C. What is the braking distance at 60 mph?
 - a. $D = (60 * .1(60))/2 = 180 \text{ feet (9 times greater than 20 mph)}$

The examples demonstrate that the higher the speed, the longer the braking distances. It also shows that as the speed doubles or triples, the increase in the braking distances is equal to the square of the differences in speed.

13. Once again, the relationship of inertia and kinetic energy is significant in relation to motor vehicle collisions. The other term that needs to be mentioned is momentum because this is the product of both speed and weight. If either weight or speed increases so does momentum. As speed increases so does the likelihood of damage in the event of a collision.
14. Not only does the size or weight of the vehicle increase the severity of the collision, but it also increases braking distance because of the momentum factor
15. Friction is the force between two surfaces that resists the movement of one surface across the other. Friction between the road and the tires of a motor vehicle is referred to as traction. Traction holds the motor vehicle on the road and enables the driver to control the motor vehicle.
16. The three types of friction or traction that are associated with operating a motor vehicle are:
- a. Static -The vehicle is not moving, it is static.
 - b. Sliding- The tire surface is sliding across the road surface. The inertia is greater than the friction. The driver does not have control.
 - c. Rolling-The tire surface is rolling across the road surface. The amount of friction enables the driver to control the motor vehicle.
17. Tire maintenance is critical in maintaining maximum contact between the tire surface and the road surface. The more tire surface on the road surface will maximize friction. Properly maintained tires would include but not be limited to the following:
- a. Inflation- Too much or too little inflation will affect traction.
 - b. Tire Wear- Worn tire treads will affect traction when the road surface is wet or covered with snow or ice.

18. Brakes need to provide maximum braking of the respective wheels. There is a great deal of friction at the brakes and this causes wear of the brake pads and shoes. There are warning signs to indicate that the brakes should be checked and possibly replaced.
19. The various types of skids that can be experienced in a motor vehicle are:
 - a. Over-Power Skid- This is when too much power is applied to the drive wheels of the motor vehicle and the wheels start to spin. If it is the front wheels, the vehicle will slide straight ahead. If it is the rear wheels, the rear of the vehicle will slide in one direction or the other.
 - b. Over-Braking Skid- A vehicle without Anti-Lock Braking System (ABS) and a hard-panic type braking by the driver might cause one or more of the wheels to lock up and slide. When the front wheels are locked and sliding, there is no steering and the vehicle will normally slide straight ahead. If the rear wheels lock up first, the back of the vehicle will slide in one direction or the other.
 - c. Front-Wheel Skid- If you turn your steering wheel and your vehicle continues to slide straight ahead, you are in a front wheel skid. The vehicle is not responding as much as you want it to. This can be caused by too much acceleration or braking in a situation where there is insufficient traction.
 - d. Rear-Wheel Skid- If your vehicle starts to move off target from where you are steering, you might be in a rear wheel skid. The back of the vehicle is starting to slide in one direction or the other. This can be caused by too much acceleration or braking in a situation where there is insufficient traction.
 - e. Skidding in a Curve- This occurs when the speed of the vehicle exceeds the available traction in a curve. The vehicle will exhibit either a front or rear-wheel skid. Skidding in a curve usually results in the vehicle going off the road surface.
 - f. Blowout Skid- This occurs when a tire suddenly loses air pressure. If a front tire blows out, there is a strong pull in the direction of the blowout. If a rear tire blows out, the rear of the vehicle will begin a side-to-side swaying or fishtailing action.
20. The selective procedures to control the various skids are:
 - a. Over-Power Skid- Ease off the accelerator until spinning stops and steer in the direction you want to go. Keep your eyes aimed high and be prepared to counter steer if the back of the vehicle starts to slide in the other direction.
 - b. Over-Braking Skid- Ease off the brake until the wheels start to roll again. If steering correction is needed, then release the brake completely until the wheels are rolling and steering control is achieved.
 - c. Front-Wheel Skid - You should release the accelerator or brake pedal pressure. Continue to look and steer in the direction you want to go. If your vehicle does not have ABS, use controlled or threshold braking (maximum braking pressure without locking the wheels).
 - d. Rear-Wheel Skid- You should release your accelerator or brake and steer in the direction you wish to go. Once you are traveling in the direction you wish to go, you can use controlled braking.
 - e. Skidding in a Curve - Observe posted speed limits and recommended speeds for curves and slow down before entering the curve. If encountering a skid, release

the accelerator or brake and steer for a safe on-road or off-road path of travel
Once steering control is achieved, use controlled braking as needed.

- f. Blowout Skid- If you encounter a blowout, do not brake. Release the accelerator, grip the steering wheel and make smooth steering corrections. Once vehicle control is achieved, gradually reduce speed by gently squeezing the brake and steer off the road surface into a safe area.
21. Hydroplaning occurs when a tire loses road contact by rising up on top of water and no longer having direct contact with the road. It is a result of depth of water, speed of vehicle, tire inflation and tread depth of tire. Hydroplaning can be avoided by having sufficient tread depth of the tires, maintain proper tire inflation, reduce speed when encountering heavy water on the road, and drive in another person's tire wiper. If experiencing hydroplaning, ease off the accelerator to reduce speed to regain rolling traction, and steer in the direction you want to go.
 22. Force of impact is defined as the force with which one moving object hits another object.
 23. The factors that affect a vehicle's force of impact in a collision are:
 - a. Speed- This is the most important factor in determining how hard one object will hit another object.
 - b. Weight-The heavier the vehicle, the greater damage that it will cause in a collision.
 - c. Distance Between impact and Final Stop- The shorter the distance between initial impact and final stop, the greater the damage.
 24. Speed is the most important factor in controlling the force of impact in a collision. The force of impact is proportional to the square of the increase or decrease in the vehicle's speed. This is why speed reduction in emergency situations is a must.
 25. The weight of the vehicle will increase the severity of a collision because a vehicle weighing twice as much as the other vehicle will hit another object twice as hard.
 26. The longer the distance between initial impact and final stop will greatly affect the severity of a collision. Hitting something forgiving such as crash barrels or a vehicle going in the same direction is more forgiving than a bridge abutment or an oncoming vehicle.
 27. A "restraint" device is a designed device that holds the vehicle's occupant(s) in place during a crash. A "passive restraint" device works automatically in the event of a crash. The occupant does not have to activate the system. An example of a "passive restraint" is the airbag. An "active restraint" device must be activated by the occupant to make it work. An example of an "active restraint" device is the safety belt.
 28. The young driver needs to be aware of the various "active" and "passive" protective systems available in the motor vehicle and how each system works.
 29. The "second collision" occurs when the unrestrained occupant collides with a part of the interior of the motor vehicle. The restraint systems eliminate or minimize the second collision by either restraining the occupant or spreading the force of the impact. The "third collision", the collision of the body organs (brain, lungs, heart, liver etc.) within the protective cavity, is also minimized by the occupant restraint system.

30. The three components or parts of total stopping distance are:
- a. Recognition Distance - This is the distance a vehicle travels from when a real or potential hazard could be identified by the driver, until the driver actually sees it and determines what action to take.
 - b. Action Distance- This is the distance a vehicle travels after a decision has been made and it is executed.
 - c. Braking Distance- This is the distance a vehicle travels after the brakes have been applied.
31. To determine how far a vehicle travels in $\frac{3}{4}$ or .75 of a second, take the first digit of a selected speed and add it to the total speed with the product identified as feet, e.g.

25 mph is $25 + 2 = 27$ feet

35 mph is $35 + 3 = 38$ feet

This, or .75 of a second is often referred to as the nationally recognized reaction time, which is the sum of recognition time and action time. This time would also be considered "simple reaction" time, because a person is prepared and ready for a certain cue before responding.

32. The reaction time associated with driving would better be classified as "complex reaction" time. The reason this is true is because a driver might not be aware of the real or potential hazards, the driver might have minimal searching skills, or there might be distractions. All of these add up to a longer reaction time or distance. These times could be 1.5 seconds or longer instead of $\frac{3}{4}$ or .75 of a second. Reaction distance can be determined with the following formula:

Reaction Distance = speed * 1.47 * reaction time

33. Vehicle and roadway factors that will affect braking distance in either a positive or negative manner are:
- a. Vehicle
 - i. Condition of tires (tread, inflation)
 - ii. Condition of shock absorbers and suspension
 - iii. Condition of brakes
 - iv. Types of brakes (ABS, standard)
 - v. Weight of vehicle
 - vi. Speed of vehicle
 - b. Roadway
 - i. Type of roadway surface (concrete, asphalt, gravel, etc.)
 - ii. Materials on the roadway surface (rain, snow, ice, leaves, mud, frost, etc.)
 - iii. Hills (down, up)
34. Being aware of the four to six seconds stopping distance is important to collision free driving. This means that the driver must identify and evaluate all potential collisions in advance of the four to six seconds and then respond. Responding within four to six seconds from the potential collision allows for a collision free zone. If a driver does not

respond until the potential collision is less than four seconds of the projected path of travel, then braking alone might not allow enough space to avoid a collision.

35. To practice measuring stopping distance when driving, pick a fixed reference point and start counting when you think you are four or six seconds from the reference point. If you arrive before finishing your count, then you are too short on your estimate.

Resources

1. Textbooks
 - a. Drive Right
 - b. Responsible Driving
 - c. How to Drive
 - d. License to Drive
2. Videos
 - a. Don't Let Up, AAA Foundation for Traffic Safety
 - b. Get a Grip, ADTSEA and Goodyear
 - c. Making the Grade with Tires
3. References
 - a. Pennsylvania Driver's Manual (current)

Psychological Conditions

Episode Justification

Emotions are a psychological condition that can and do affect one's behavior. The one positive aspect of emotions is they are short lived. When emotions affect one's behavior, that person may be more susceptible to high-risk behavior. Drivers must be aware of the type of emotions which can increase the risk of a crash. Drivers must be prepared to address and control these emotions.

Episode Objectives

1. Emotions that affect one's driving behavior;
2. High-risk driving behavior that emotions produce;
3. The physiological conditions affected by emotions;
4. Methods of controlling emotions when driving; and
5. Recognizing and dealing with distractions.

Performance Objectives

The student will:

- 1.1. Write a brief definition of the term "emotions,"
- 1.2. List the types of emotions that can have an adverse effect on one's driving behavior;
- 2.1. Identify the types of high-risk driving behavior that can be the result of emotions;
- 3.1. Describe the physiological conditions that emotions affect in a negative manner;
- 4.1. Explain selective methods of dealing with emotions when driving a motor vehicle;
- 4.2. Define aggressive driving and give examples of this type of behavior;
- 4.3. Identify ways of dealing with aggressive drivers;
- 4.4. Define "road rage" and give examples of this type of behavior;
- 4.5. Identify ways of dealing with a potential "road rage" situation;
- 5.1. List the types of distractions that can have a negative effect on one's driving; and
- 5.2. Explain methods of reducing the risks associated with distractions when driving a motor vehicle.

Content

1. Emotions can be defined as a temporary altered psychological condition that may produce unexpected or illogical behavior. A person who is emotionally upset might exhibit behavior that he/she would not normally demonstrate. Emotions are short lived and when one allows emotions to affect his/her behavior, then he/she is at greater risk because it can affect the ability to think, reason and make judgments.
2. Emotions that can affect one's driving behavior are:
 - A. Pleasant emotions such as joy, happiness, etc., can take one's attention away from the driving task.

- B. Unpleasant emotions such as fear, hate, anger, anxiety, grief, etc., can also distract a driver and in some instances, make the driver aggressive or reckless.
3. Drivers who allow their driving behavior to be affected by emotions might exhibit the following high-risk driving behaviors:
 - A. Tailgating or following too close behind another vehicle;
 - B. Passing on hills or curves;
 - C. Driving too fast for conditions;
 - D. Using the horn an excessive number of times;
 - E. Being erratic with their speed control, e.g., hard acceleration and hard brake;
 - F. Being erratic with their steering control;
 - G. Not identifying traffic control devices; and
 - H. Not communicating with turn signals.
 4. The physiological conditions that are affected by emotions in a negative manner are:
 - A. Increased heart rate;
 - B. Increased blood pressure;
 - C. Tunnel vision;
 - D. Short sight distance;
 - E. Focus or stare a short distance in front of vehicle;
 - F. Muscles tighten; and
 - G. Digestion slows.
 5. If one is emotionally upset, then he/she should delay driving a motor vehicle. Ways to deal with emotions when driving a motor vehicle are:
 - A. Be aware of situations that tend to upset you.
 - B. Expect other drivers to make mistakes and search for clues to predict these errors.
 - C. Direct emotions at another person's actions and not the person
 - D. Control emotions by:
 - i. Loosening the hand grip on the steering wheel.
 - ii. Breathe deeply.
 - iii. Listen to favorite music.
 - iv. Keep the climate control at a comfortable setting.
 6. Aggressive drivers usually exhibit high risk driving behaviors and focus all of their attention on themselves and their wants. Aggressive drivers usually demonstrate the following types of behavior:
 - A. Tailgate or follow too close;
 - B. Quick to use their horn (extremely impatient);
 - C. Flash their headlights;
 - D. Pass in no-passing zones;
 - E. Pass on the right using the shoulder of the highway,
 - F. Take shortcuts through businesses at intersections;
 - G. Use threatening gestures toward others;
 - H. Speed in limited space situations; and
 - I. Continuously weaving in and out of traffic lanes and cutting off other drivers.

7. The easiest way to deal with aggressive drivers is to focus on their action or expected actions and not the individual. Avoid getting emotionally upset with their high-risk behavior, you do not want to get them angrier or allow your emotions to affect your driving behavior in a negative manner. You can lessen the threat of aggressive drivers by:
 - A. Giving them greater space;
 - B. Moving over when available, allowing them to pass;
 - C. Avoiding eye contact whenever possible; and
 - D. Avoiding any retaliation with horn, headlights or gestures.
8. Drivers who exhibit "road rage" are actually attempting to hurt or injure another person and/or damage the other person's property by using their own vehicle or some type of instrument as a weapon to do harm or damage. Examples of this type of behavior could include but not be limited to:
 - A. Bumping or pushing another vehicle from behind to cause the driver to lose control;
 - B. Side-swiping another vehicle to cause the driver to lose control;
 - C. Intentionally braking hard when in front of another vehicle, attempting to cause the other driver to collide or lose control;
 - D. Intentionally driving into the path of an oncoming vehicle, attempting to cause them to lose control;
 - E. Intentionally disregarding a stop sign or red light at an intersection; and
 - F. Using a firearm or some other type of weapon to harm the other driver or to damage the other driver's vehicle.
9. The best way to deal with a potential "road rage" situation is to look for clues that this might happen and put as much space between you and the aggressive person. Avoid actions that the other person might interpret as a challenge. Given the opportunity, report this incident to the police as soon as possible.
10. Distractions that can affect one's driving behavior include but are not limited to:
 - A. Passengers and their behavior;
 - B. Eating food or drinking a beverage;
 - C. Using a communication device (cellular phone, CB, etc.);
 - D. Using the radio, tapes, CD;
 - E. Reading a map; and
 - F. Scenery.
11. Ways to reduce the risks associated with the various distractions in the motor vehicle are:
 - A. Control the actions and behavior of the passengers;
 - B. Know directions ahead of time and use a quick reference card or rely upon a co-pilot when available;
 - C. Try to avoid eating or drinking when driving. If you need to, then only do so when there are little, or no risks identified; and
 - D. Begin radio, tape, CD selection prior to leaving. If there is a need to select, then do so when there are little, or no risks identified.

Resources

1. Textbooks
 - a. Drive Right
 - b. Responsible Driving
 - c. How to Drive
 - d. License to Drive
2. References
 - a. Pennsylvania Driver's Manual (current)
3. Stop- Think and Go Decision-Making Case Study
 - a. You are at your boyfriend/girlfriend's home and you have just had an argument and are extremely angry. You want to leave there immediately. What should you do?
 - i. Leave immediately in your car to cool down.
 - ii. Leave by walking.
 - iii. Wait at the home to cool down before driving.
 - iv. Leave immediately in your car and pull over and stop as soon as possible to cool down.
 - b. The car that you are driving is a sub-compact, and it is designed for no more than four occupants including the driver. Therefore, there are only four sets of safety belts. While you and a friend are at the local mall, you meet three other friends. When you are getting ready to leave, they ask if you can drive them to another location which is approximately four miles. Your parents have always insisted that you never have more passengers than there are safety belts in the car.

Physiological Conditions

Episode Justification

The State requires certain physical conditions be met before being licensed as a driver in Pennsylvania. New drivers need to be aware of these conditions and understand why they are essential to safe driving. New drivers also need to be aware of the elderly drivers and the limitations that they encounter in relation to their physical conditions. This awareness and understanding will better enable the driver to look for clues in relation to the older driver and better predict their actions. A physical condition that cannot be tested but is certainly a contributing cause to many of our highway crashes is fatigue. Awareness of this problem will lead to a better understanding and the ability to reduce its related risks when driving a motor vehicle.

Episode Objectives

1. Physical requirements to be licensed as a driver;
2. Physical limitations associated with the elderly drivers;
3. Fatigue and its negative effect on driving performance; and
4. Short term illnesses and medications that affect driving performance.

Performance Objectives

The student will:

- 1.1. Identify the visual requirements that are tested at the license exam center;
- 1.2. Identify visual deficiencies that require corrections to enable a person to drive without limitations;
- 1.3. Identify visual deficiencies that allow a driver to drive with limitations;
- 1.4. Identify other physical conditions that are examined by a certified physician prior to licensing;
- 1.5. Identify physical limitations that can be corrected to enable a person to satisfy the licensing standards;
- 2.1. Identify the physical deficiencies that older drivers will encounter;
- 2.2. Explain how older drivers compensate for their physical limitations;
- 2.3. Identify ways of decreasing the risk of a collision with an older driver;
- 3.1. Identify and explain the physiological conditions associated with fatigue;
- 3.2. Identify and describe how fatigue can become a problem when driving a motor vehicle;
- 3.3. Describe actions that a driver can take to reduce the risks associated with fatigue;
- 4.1. Identify types of illnesses that have a negative effect on one's driving performance;
- 4.2. Identify the types of over-the-counter medication that can have an adverse effect on driving performance; and
- 4.3. List and describe the types of driving behavior that can be caused by illness and/or medication.

Content

1. The visual examination at the exam center is a screening of the applicant's eyesight with or without corrective lenses. The applicant could also be restricted to daylight driving or be allowed to operate only vehicles equipped with outside mirrors. If the applicant fails to meet the vision standards, then he/she must have the respective medical professional complete Form DL-102, Report of Eye Examination, before any further testing.
2. Visual deficiencies that require corrections to enable a person to drive without limitations are:
 - a. Visual Acuity- Normal visual acuity is 20/20. States set minimums for visual acuity, and if the applicant cannot meet these minimums then he/she would need corrective lenses to drive without limitations.
 - b. Tunnel Vision- A person with tunnel vision has a very narrow field of vision. A narrow field of vision of 140 degrees or less would require the driver to have additional mirrors on the car.
 - c. Color Blindness - A person suffering from a form of color blindness cannot have it corrected, but he/she can drive without limitations.
3. Visual deficiencies that allow persons to drive with limitations are:
 - a. Night Blindness -Persons who cannot see at night can drive only during daylight hours.
4. Physical conditions that are examined by a certified physician to satisfy the licensing standards are:
 - a. Neurological disorders;
 - b. Cardiac or circulatory disorders, e.g., hypertension;
 - c. Neuropsychiatric disorders;
 - d. Conditions causing lapses of consciousness, e.g., epilepsy, narcolepsy, hysteria;
 - e. Alcoholism;
 - f. Narcotic addiction;
 - g. Uncontrolled epilepsy; and
 - h. Immobility or amputation of an appendage.
5. Physical limitations that can be corrected to enable a person to satisfy the licensing standards are:
 - a. Any neurological or neuropsychiatric disorder must be demonstrated that it is under control and it will not interfere with the safe operation of the vehicle.
 - b. Any physiological disorder that can cause one to lose consciousness must be demonstrated that it is under control and it will not interfere with the safe operation of the vehicle.
 - c. Immobility or amputation of an appendage can be corrected with adaptations to the motor vehicle.
6. Some of the physical deficiencies that the older driver will encounter are:
 - a. Slower Reaction Time- Aging slows reflexes and the older driver is slower and more deliberate in their actions.

- b. Reduced Vision and Concentration - The vision of the older driver is reduced at night and glare becomes a greater problem. Driving in an unfamiliar area or in heavy traffic will cause a great deal of stress for the older driver.
 - c. Reduced Flexibility and Muscle Strength - The ability to turn and look is restricted and this occurs at intersections, interchanges, backing, lane changes, etc.
 - d. Reduced Depth Perception and Field of Vision- This will cause the older driver to make poor decisions regarding a safe gap selection and also miss seeing certain traffic controls and other users to the sides.
7. Older drivers can compensate for their physical limitations by:
- a. Avoiding driving during high volume times.
 - b. Avoiding metropolitan areas during high volume times.
 - c. Avoiding driving at night.
 - d. Setting mirrors to reduce the blind spots around the vehicle.
 - e. Maintaining a level of fitness and flexibility.
 - f. Using a selective visual search pattern.
8. Ways to minimize the risk of a collision with an older driver would include but not be limited to:
- a. Searching for probable clues that the older driver might enter your projected path of travel.
 - b. Maintaining a larger space cushion from the older driver.
 - c. Avoiding distracting actions around an older driver, e.g., blowing your horn, tailgating.
9. The physiological conditions associated with fatigue are:
- a. Senses are dulled and there is a longer reaction time.
 - b. Vision is affected, e.g., experience tunnel vision, shorter sight distance, slower reflex reaction in the eye, and slower glare recovery.
10. Fatigue becomes a problem when operating a motor vehicle because:
- a. The senses are dulled and the process of identifying, evaluating and responding are slowed down.
 - b. The driver has trouble keeping his/her head up.
 - c. The driver tends to drift to the right or left of the lane.
 - d. The driver's eyes will close and/or go out of focus.
 - e. The driver has difficulty focusing on the driving task.
11. A driver can combat fatigue with the following activities:
- a. Get plenty of rest before a long trip;
 - b. If other drivers are available, change every two to three hours;
 - c. Take a break every two hours;
 - d. Use sunglasses when there is a great deal of daytime glare;
 - e. Use a disciplined search pattern;
 - f. Listen to the radio, talk to the passengers; and
 - g. If you do need to stop and rest, be sure it is a safe and secure area.
12. Illnesses that can and do affect the safe operation of a motor vehicle include but are not limited to:
- a. Colds

- b. Allergies
- c. Flu-like symptoms
- d. Temporary physical injury such as a fracture, severe sprain, etc.

These and other temporary conditions can dull one's senses and be a distraction when trying to operate the motor vehicle.

13. Over-the-counter medications should be closely examined by the driver because a good many of them can have an adverse effect on one's driving performance. The consumer should look closely at the following information:
 - a. The intended use of the medication;
 - b. The dosage;
 - c. Any warnings;
 - d. Any cautions; and
 - e. The ingredients.
14. The driving behaviors associated with illnesses and/or medications can be comparable to a person driving under the influence of alcohol. There are many similarities, and the only thing missing is the alcohol.

Resources

1. Textbooks
 - a. Drive Right
 - b. Responsible Driving
 - c. How to Drive
 - d. License to Drive
2. Other Resources
 - a. Pennsylvania Vehicle Code (current)
 - b. Pennsylvania Driver's Manual (current)

Adverse Conditions

Episode Justification

Adverse conditions and night driving can create emergency situations. Emergencies often lead to a panic response or no response at all. A review of nearly 12,000 reported collisions revealed that more than 37 percent of the involved drivers took no action to prevent or avoid the collision. In 1996, Pennsylvania collision data showed that adverse conditions contributed to 26 percent of all reported collisions. Deaths on Pennsylvania highways during non-daylight hours (dark and dusk conditions) occurred more often than daylight hours in 1996. Night collisions resulted in 80 percent more deaths than daylight collisions. Young drivers need to understand how to recognize adverse conditions and how to reduce the risks associated with these conditions. It is always easier to eliminate or minimize the risk of losing vehicle control than it is to regain control once it is lost.

Episode Objectives

1. To make the students aware of what constitutes adverse conditions;
2. To inform the students of the risks created by low visibility at night;
3. To show the students what constitutes low visibility and how it creates adverse driving conditions;
4. To show the students that reduced visibility can be caused by weather, the highway environment, other traffic, and one's own vehicle;
5. To increase the students' knowledge and skill for addressing the problems associated with low visibility;
6. To inform the students how reduced traction can be caused by vehicle and highway conditions;
7. To make the students aware of traction problems during the early part of a rainfall;
8. To show the students how reduced traction increases the possibility of skidding and loss of control;
9. To inform the students of the three types of skids, how to prevent these skids and the actions needed to correct them; and
10. To familiarize the students about hydroplaning and actions needed to avoid it.

Teaching Point: There is a section in the Perception and Driving Strategies for Different Environments that deals with night driving. This would be the most appropriate time to teach all of the objectives relating to adverse conditions. There are also performance objectives in this unit that are interrelated with the unit Natural Laws In Relation to Driving A Motor Vehicle.

Performance Objectives

The student will:

- 1.1. Define adverse driving conditions and give several examples;
- 1.2. Describe the various risks that are associated with adverse driving conditions;
- 2.1. Compare the highway death rates at night versus daytime;

- 2.2. Explain how visual sight distance is reduced at night;
- 2.3. Explain why pedestrians and animals are difficult to see at night;
- 2.4. Describe how reaction time is significantly slowed at night;
- 2.5. List the ways that glare is increased at night and explain why this is such a problem;
- 2.6. Identify how "depth perception" is significantly affected at night;
- 2.7. Explain how the visual search pattern used at night is significantly different from daytime;
- 3.1. Identify other adverse conditions that limit the driver's visibility;
- 3.2. Explain how less visibility increases the risk of a collision;
- 4.1. Explain how rain, snow and fog affects the driver's ability to see and be seen;
- 4.2. Explain how smoke and dust affects the driver's ability to see and be seen;
- 4.3. Identify certain locations in the highway environment that reduces the driver's ability to see and be seen;
- 4.4. Identify how other traffic affects the driver's ability to see and be seen;
- 4.5. Identify how a driver's ability to see and be seen can be caused by one's own vehicle;
- 5.1. List and describe certain pre-ignition procedures that can help address the problems associated with low visibility;
- 5.2. List and explain three searching techniques that will help reduce the risks associated with driving in low visibility condition;
- 5.3. Describe techniques of reducing glare when driving in low light conditions;
- 5.4. Explain the term of "overdriving headlights or visibility" and identify techniques to reduce this risk;
- 5.5. Identify maneuvers that possess a greater risk with low visibility and how to reduce these risks;
- 6.1. Explain the role of traction for maintaining control of the motor vehicle;
- 6.2. Identify specific features of the motor vehicle that can have a positive or negative effect on traction;
- 6.3. Describe the importance of tire maintenance and its effects on traction;
- 6.4. Identify features of the highway that can have a positive or negative effect on traction;
- 6.5. Identify weather conditions that affect the traction of a vehicle;
- 7.1. Explain why the risk of reduced traction is greatest during the early part of a rainfall;
- 7.2. List the driving actions that will help to reduce the risk of skidding during the early part of a rainfall;
- 8.1. Identify how reduced traction increases the possibility of skidding and loss of control;
- 8.2. Explain the concept that locked sliding wheels cannot be steered;
- 8.3. Demonstrate how locked sliding wheels on a slippery surface will always go further than controlled braking wheels;
- 8.4. Demonstrate how locked sliding wheels will always want to lead;
- 9.1. Identify the three types of skids that a driver can encounter when driving a vehicle and the locations or environments where there are greater risks for these selective skids;
- 9.2. Explain what "controlled" or "threshold" braking means and the driver action to execute this braking technique;
- 9.3. Define "ABS" and explain the braking procedure for an "ABS" equipped vehicle;
- 9.4. Describe the use of the accelerator in avoiding a power skid;

- 9.5. Describe the steering technique to avoid a steering skid;
- 9.6. List and explain the procedures for recovering from selected skids;
- 10.1. Define the term "hydroplaning";
- 10.2. Identify the roadway and vehicle conditions that increase the risk of "hydroplaning";
- 10.3. Identify selected countermeasures that reduce the risk of "hydroplaning"; and
- 10.4. Explain the steps to follow if a vehicle begins to hydroplane.

Content

1. Adverse driving conditions are usually environmental conditions that can and do increase the risk of a collision. Examples of adverse driving conditions would be those that affect visibility (seeing and being seen) and those that affect traction.
2. Reduced visibility increases the risk of a collision. Reduced traction increases the risk of a collision.
3. Death rates at night are two and one-half times greater in rural areas and three times greater in urban areas when compared to daylight death rates.
4. At night, high beams allow for approximately 500 feet of visual acuity when the vehicle is not moving and low beams allow for approximately 150 feet of visual acuity. When the vehicle is moving at approximately 30 mph, visual acuity on low beams drops to approximately 90 feet.
5. Pedestrians and animals are low reflective objects and with a vehicle using low beams, these objects adjacent to the roadway are not visible beyond 66 feet.
6. At night, a driver can add anywhere from one and one-half to two seconds to their normal reaction time because of low light conditions and the need to focus longer on something before identifying what it is.
7. Headlight glare is a significant problem because it reduces visual acuity. Maximum visibility with two cars approaching and both using low beams is 200 feet. When two vehicles are 100 feet apart, it is difficult to see objects beside or beyond the approaching vehicle. Headlight glare can also come from vehicles behind and alongside and this is coming from the rearview and side view mirrors. Glare can also come from the panel lights.
8. The road surface is used as a reference point to assist depth perception. At night, it is difficult to use the road surface as a reference point and speed of closure is difficult to measure when using oncoming headlights or ongoing taillights.
9. Longer fixation on areas of the environment is needed to acquire and process information. On unlit roads, the driver needs to glance at the road edges and surfaces to help in positioning the vehicle.
10. Sun glare, fog, dawn and dusk, rain, snow, dust and smoke all have the potential to reduce a driver's visibility.
11. Less visibility refers to what and how well the driver can see when behind the steering wheel of a motor vehicle. It also refers to the ability of other drivers to see you.
12. Rain, snow and fog diffuse the beams of the headlights especially on high beams and they reduce sight distance.
13. Smoke and dust are something that suddenly occur and remain only in a small area. Vision is suddenly reduced and this is why there is a sudden risk of a collision.

14. Examples of highway locations that affect sight distance and view to the sides are:
 - a. Crest of hills;
 - b. Curves; and
 - c. Blind intersections.
15. Other traffic is referred to as dynamic conditions that can and do affect visibility. Examples of these are:
 - a. Trucks;
 - b. Buses; and
 - c. Any large vehicle.
16. There are blind spots in one's own vehicle and these locations can and do restrict a driver's visual acuity. Some of these objects can be permanent such as mirrors and decals. Others can be temporary such as boxes or other items loaded into the motor vehicle. Passengers can also limit a driver's visibility.
17. The following are special pre-ignition procedures for night driving that can help address some of the problems associated with night driving:
 - a. Check intended path before getting into car;
 - b. Clean windows (inside and out) at night are critical;
 - c. Engine running, check high/low beam switch;
 - d. Adjust panel lights;
 - e. Check day/night mirror; and
 - f. At least once per month, check all of the communication lights (brake, turn signals, and back-up, emergency flashers). Do this after engine is running and headlights are turned off.
18. The following are special searching techniques that help to reduce the risk of less visibility when driving at night:
 - a. Search to limits of headlight range;
 - b. Search beyond the headlight range for visible clues; and
 - c. Check reference point to right for lane positioning.
19. Reducing glare at night:
 - a. When meeting other vehicles, focus on right lane line and periodically use a low glance at the oncoming vehicle to check its lane position. Keep your eyes from looking directly into the headlights of the oncoming vehicle.
 - b. Adjust side mirrors out and put rearview mirror on night setting.
 - c. Reduce light intensity on panel lights.
20. Overdriving one's headlights means that the driver's stopping distance is greater than the seeing distance, and the ways to help reduce this risk are:
 - a. Reduce speed;
 - b. Allow greater following distance;
 - c. Look beyond vehicle in front of you and use that vehicle's headlights; and
 - d. Search for visual clues outside the lateral range of the headlights.

21. Certain maneuvers at night possess a greater risk than during daylight hours. Some of these maneuvers are:
- a. Turning - headlights do not go around corners. They illuminate the path immediately in front of the vehicle. To reduce this risk:
 - i. Reduce speed
 - ii. Look through turning path beyond the headlights
 - iii. Do not allow your eyes to only follow the headlight beam
 - b. Backing- Visibility is reduced when backing. Back-up lights are primarily for communication. To reduce this risk:
 - i. Check intended path before getting into car
 - ii. Back slowly and search in direction you are backing
 - c. Changing Lanes- Judging the speed of closure from behind is more difficult at night because you only have the headlights to see in the mirror. To reduce this risk:
 - i. Allow extra clearance to the rear before changing lanes
 - ii. Practice judging the speed of vehicles from behind by observing their movement and position of their headlights in your rearview mirror.
 - d. Passing- Passing left of center on a two-lane road is a high-risk maneuver during daylight, and it is even a greater risk at night. Reasons for passing at night seldom justify the involved risks.
22. Traction allows us to control the speed and direction of our vehicle.
23. Height, width, weight, front wheel drive, rear wheel drive are all features of a vehicle that can affect traction in a positive and/or negative manner.
24. Tread depth, tire pressure, tire rotation and others are all part of tire maintenance regarding traction.
25. Highway Features:
- a. Composition of roadway surface (concrete, asphalt, gravel);
 - b. Smoothness, roughness, unevenness of surface;
 - c. Flat, crowned, banked roadways;
 - d. Shoulders or berm; and
 - e. Bridges
26. Weather conditions:
- a. Rain
 - i. First rain vs. prolonged periods.
 - ii. Standing water.
 - iii. Hydroplaning.
 - b. Snow
 - i. Fresh, loose snow.
 - ii. Traffic packed.
 - iii. Shaded areas.
 - iv. Bridges.
 - c. Ice
 - i. Reduce speed.
 - ii. Black.

27. Early rainfall has greatest risk of reduced traction because of all the oil and other substances that rise on top of the water.
28. Some of the driving actions that help reduce the risk of skidding during the early part of a rainfall are:
 - a. Reduce speed;
 - b. Drive in the tire wipes of other vehicles; and
 - c. Drive gently (smooth steering, accelerating, braking).
29. When a vehicle loses traction, momentum takes over and causes the vehicle to go where you don't want it to go.
30. When front wheels are locked and sliding, there is no steering control
31. Locked sliding wheels on a slippery road surface will always go further than controlled or threshold braking.
32. If rear wheels on a vehicle begin to skid, they will always want to lead.
33. The types of skids and where they generally occur are:
 - a. Power Skid;
 - i. Tires start to spin when the driver accelerates (presses the accelerator too far).
 - ii. Most occur on slippery surfaces (can happen with front and rear wheel drive vehicles).
 - iii. The vehicle will usually veer to one side.
 - iv. Ease off accelerator.
 - v. Make steering corrections as necessary.
 - b. Braking Skid;
 - i. Braking too hard causes locked wheels.
 - ii. When wheels stop rolling, tires lose traction, stopping distance may increase and steering ability is lost.
 - iii. Can happen on wet roads or roads covered with sand, gravel, leaves, ice or snow.
 - iv. Can happen if you slow down suddenly in an emergency situation.
 - v. To control braking skid, release the brakes just enough to allow the wheels to rotate.
 - c. Sideways Skid
 - i. Caused by entering a curve too fast.
 - ii. Tires do not have enough traction to hold you in the curve.
 - iii. Since excessive speed is causing the skid, the driver needs to decelerate, and brake as needed.
34. Controlled braking is squeezing the brake pedal just to the point of a lock-up. This gives maximum braking without lock-up and still maintaining steering capabilities.
35. Anti-lock Braking System (ABS)
 - a. Do not pump the brakes - keep your foot on the brake pedal and squeeze.
 - b. ABS was developed to assist driver braking actions when impending wheel lock-up could occur.

- c. ABS allows the braking action to occur in a more efficient manner by providing the jabbing (squeezing) action automatically while the driver maintains steady brake pressure.
 - d. By not allowing the brakes to lock up, the driver has steering control.
 - e. ABS does not defy the laws of physics, it does not shorten braking distances.
36. Using the accelerator to avoid a power skid, the driver should squeeze the accelerator gently and if skidding starts to occur, ease off the accelerator.
37. To avoid a steering skid, the driver should reduce speed going into the turn and only steer as much as needed and use smooth steering input.
38. Responding to a rear-wheel skid involves the following:
- a. Remove your foot from the accelerator or brake;
 - b. Steer in the direction you want to go;
 - c. Keep your eyes directed out to where you want to go. Do not allow your eyes to drop in an emergency;
 - d. Be ready for counter steering when vehicle responds to steering input; and
 - e. Only use the brake after the vehicle is stabilized and going where you want it to go.
39. Hydroplaning occurs when a wedge of water builds up between the road surface and the tire surface.
40. Roadway condition that causes hydroplaning is usually standing water on the road surface. Vehicle conditions are usually related to poor tire maintenance.
41. To reduce the threat of hydroplaning:
- a. Reduce speed;
 - b. Good tire tread;
 - c. Proper tire inflation;
 - d. Drive in another vehicle's tire wipes; and
 - e. Minimize steering and speed control input (drive gently).
42. Steps if experiencing hydroplaning:
- a. Ease off the accelerator to reduce speed;
 - b. Maintain firm grip on the steering wheel and avoid hard steering actions; and
 - c. If using brake, squeeze it firmly.

Resources

1. Textbooks
 - a. Drive Right
 - b. Responsible Driving
 - c. How to Drive
 - d. License to Drive
 - e. Safety Sense
2. Videos
 - a. Night Driving, AAA Foundation for Traffic Safety
 - b. Ready, Set, Winter, AAA
 - c. Get a Grip, ADTSEA and Goodyear
 - d. Don't Let Up, AAA Foundation For Traffic Safety

3. Instructional Guide
 - a. The ABS Education Alliance
4. Stop- Think and Go Decision-Making Case Studies
 - a. Use pictures from the textbook, slides and/or traffic crashes from the local newspaper that can be used as case studies for applying-the decision-making model.
 - b. Case Study

It is a beautiful clear winter day and you have just passed your driver's test for your license the previous week.

When you get home from school on Friday afternoon, you ask your parents if you can have the car to go to the dance at school that night. After much discussion, they agree you can have the car but only to go to the dance and to be home by 11p.m.

You ask if you can pick up your best buddy "Bill" on the way to the dance, and your parents agree you can pick up Bill but no one else. You agree and are on your way to pick up Bill and then to the dance.

You pick up Bill and go to the dance, but the dance is a bummer and Bill suggests that we go to Jane's house for a party.

You figure OK, Mom and Dad won't find out as long as you are home in time, so you drive to Jane's house. When you are ready to leave Jane's house, you discover it is snowing and the roads are all covered with a fine layer of snow.

"What do you do?"

Should you drive home in the light snow? Should you call Mom and Dad and tell them where you are and have them come for you?

Alcohol/Other Drugs

Episode Justification

Collision research shows that the use of alcohol and other drugs contributes to at least one third of the fatal collisions which occur annually in Pennsylvania. Many of these collisions are the result of teenagers who chose to drink and drive, rode with an impaired driver or were hit by a drunk driver. The goal of this unit is to provide students the guidance necessary to assist them in making responsible decisions concerning the use of substances which may impact on safe driving. By knowing the rules, recognizing the consequences, and recognizing alternative behaviors, students will be able to make responsible decisions concerning their use of alcohol and other drugs.

Episode Objectives

1. The impact of alcohol and other drugs on the causation of crashes and deaths;
2. Information about ethyl alcohol;
3. How alcohol affects the blood alcohol concentration (BAC) or blood alcohol level (BAL);
4. The factors within the human body that determine blood alcohol concentration levels;
5. How alcohol is processed out of the body and the time needed for elimination;
6. Laws relating to the use of alcohol;
7. Methods for identifying alcohol impaired drivers and appropriate actions to take
8. Methods for identifying a person who is impaired and appropriate actions to keep them from driving; and
9. Other drugs that can affect a person's ability to operate a motor vehicle.

Performance Objectives

The student will:

- 1.1. Record and analyze collision data for alcohol/drug related collisions;
- 1.2. Describe the increased threat when sharing the road with an alcohol/drug impaired driver;
- 1.3. Identify personal examples of alcohol/drug related collisions;
- 1.4. Explain why alcohol is a greater problem for young and inexperienced drivers;
- 2.1. Identify that all alcoholic beverages contain the same drug;
- 2.2. Identify the different misconceptions about alcohol and explain why they are not true;
- 2.3. Explain the difference between beer, wine and distilled spirits;
- 3.1. Define blood alcohol concentration or blood alcohol level;
- 3.2. Describe what is considered a serving of alcohol;
- 3.3. Explain how alcohol is absorbed into the bloodstream;
- 3.4. Identify the time required for alcohol to be absorbed into the bloodstream;
- 4.1. Explain how body weight influences blood alcohol concentration;
- 4.2. Describe how the gender of the person will influence blood alcohol concentration;
- 4.3. Explain how the rate of consumption will affect the blood alcohol concentration;

- 4.4. Describe how the strength of the alcohol consumed will affect the blood alcohol concentration;
- 4.5. Explain the effect that food in the stomach will have on the blood alcohol concentration;
- 4.6. Calculate the blood alcohol concentration of selective case studies;
- 4.7. Explain what effect experience has on the blood alcohol concentration;
- 4.8. Explain what role tolerance has on the blood alcohol concentration;
- 4.9. Explain how one's psychological moods alter the effects of alcohol;
- 5.1. Explain how alcohol is eliminated from the body;
- 5.2. Identify the rate of alcohol elimination from the body;
- 5.3. Calculate the length of time required to eliminate a given amount of alcohol;
- 5.4. Describe the wisdom of "If you drink, don't drive, if you drive, don't drink";
- 6.1. Identify the various laws relating to alcohol use and the young person and persons 21 years of age or older;
- 6.2. Explain that killing someone while driving under the influence of alcohol will result in a mandatory jail sentence of three years;
- 6.3. Define actions that can constitute underage drinking;
- 6.4. Outline the penalties for conviction of underage drinking;
- 6.5. Define "zero tolerance" as it applies to drivers under 21 years of age;
- 6.6. List the penalties assessed when a driver under the age of 18 is convicted of drunk driving;
- 6.7. Enumerate the penalties assessed when a driver between age 18 to under age 21 is convicted of drunk driving;
- 6.8. Explain the significance of 0.10% blood alcohol concentration applied to a driver 21 years of age or older;
- 6.9. List the penalties for a driver 21 years of age or older who is convicted of drunk driving;
- 6.10. Explain why multiple tests may be administered to drivers who are believed to be impaired by alcohol or other drugs;
- 6.11. Describe the significance for a driver 21 years of age or older and blood alcohol concentration less than 0.10% but greater than 0.05%;
- 6.12. Explain the role and application of the "Implied Consent Law";
- 6.13. Describe the relationship of a drunk driving conviction and increase insurance costs;
- 7.1. List the driving characteristics of a driver who is operating a motor vehicle while impaired;
- 7.2. Identify and demonstrate safe and appropriate driving actions when confronted with a driver who is impaired;
- 8.1. Analyze the risk of choosing to ride with a driver who has been drinking;
- 8.2. List and describe impairment characteristics of a person who has been drinking;
- 8.3. Explain the responsibilities of responding to a person who has been drinking and wishes to drive;
- 8.4. Identify alternatives for a person who has been drinking and wishes to drive;
- 9.1. Identify common over-the-counter drugs which can impair a person's ability to operate a motor vehicle and the type of impairment from the selected drugs;

- 9.2. Identify commonly abused drugs and what effect they have on driving performance;
- 9.3. Explain the "synergistic" effect in relation to drugs;
- 9.4. Explain how prescription drugs can affect a person's driving performance; and
- 9.5. Explain how huffing or sniffing certain inhalants affects the driving performance.

Content

1. Data is readily available from the Pennsylvania Department of Transportation's annual report on highway crash data.
2. Drivers that are impaired or under the influence of alcohol increase the risks of a collision because of the mistakes that they can and do make thus threatening the lives of themselves, their passengers and other highway users.
3. Have the students cite personal examples of how their families or families that they know were impacted by a drinking driver.
4. The young driver needs to focus an of his/her attention on the driving task. Alcohol is a depressant and it will impair the attention and decision-making process of the new and inexperienced driver.
5. The student will identify that alcoholic beverages contain the same drug.
 - a. Ethyl alcohol is the by-product of brewing, fermenting or distilling;
 - i. Grains, plant products and fruits are used to create an alcohol beverage.
 - ii. The flavor of the beverage comes from the fruit, plant, grain or the aging container.
 - b. The common ingredient is ethyl alcohol.
6. The student will identify the different misconceptions about alcohol and why they are not true.
 - a. Alcohol can be burned off by strenuous activity;
 - i. Some alcohol is released through perspiration - about 2 percent of total.
 - ii. Most people under the influence are unable to do strenuous activity.
 - iii. Time is the only way to know the body to eliminate alcohol through oxidation.
 - b. Black coffee reduces the effect of alcohol;
 - i. The caffeine in coffee may make you more alert temporarily but your BAC level will remain the same.
 - ii. Time is the only way to allow the body to eliminate alcohol through oxidation.
 - c. A cold shower will reduce the effect of alcohol;
 - i. The cold water will definitely give a person under the influence a temporary jolt
 - ii. Time is the only way to know the body to eliminate alcohol through oxidation.
 - d. Beer does not get you as drunk as liquor;
 - i. A 12-ounce bottle or can of beer has the same amount of alcohol as an average cocktail
 - ii. The only difference is that there is more volume in a beer and it may take longer to drink than a smaller volume cocktail

- e. You can build up a tolerance to alcohol;
 - i. You may become accommodated to the effects of alcohol on your vision and balance but it still has control over your judgment.
 - ii. Your Blood Alcohol Content (BAC) level will continue to be the same - you cannot change that!
 - f. You can drive better after a few drinks;
 - i. Your judgment and reasoning is affected after the first drink.
 - ii. Your inhibitions may be lowered allowing you to take risks you would not normally take.
 - g. Young people cannot become problem drinkers.
 - i. Some young people become problem drinkers even though their drinking is confined to weekends.
 - ii. Binge drinking may not make you an alcoholic, but it might kill you due to alcohol poisoning.
7. The student will learn the difference between beer, wine and distilled alcohol.
- a. Beer (12 oz.) has just over a half-ounce of pure alcohol per serving= 5 percent of total;
 - i. It is fermented then mixed with other ingredients
 - ii. There are many different types of beer, with various alcohol contents and flavors.
 - 1. National brands which contain similar amounts of alcohol.
 - 2. Microbrews that can or do contain higher amounts of alcohol.
 - 3. Malt brews that can or do contain higher amounts of alcohol.
 - iii. There are various ways to be served beer which can lead to confusion when trying to keep track of each serving.
 - 1. Cans of various sizes.
 - 2. Bottles of various sizes.
 - 3. Taps, kegs, pitchers with various sized glasses
 - b. Wine (4-6oz) has just over a half ounce of pure alcohol per serving = 12 percent of total; and
 - i. It is fermented.
 - ii. There are many different types of wine, with various alcohol contents and flavors.
 - 1. Red wines and variations of red wines
 - 2. White wines and variations of white wines
 - 3. Champagne
 - 4. Wine coolers - 1 cooler equals 1.5 drinks
 - 5. Fortified wines have higher alcohol content up to 20% of the total
 - iii. There are various ways to be served wine which can lead to confusion when trying to keep track of each serving.
 - 1. By the glass
 - 2. Carafe
 - 3. Bottle

- c. Distilled Liquor (1 to 1.5 oz.) has just over a half-ounce of pure alcohol per serving = 40 percent or more of total.
 - i. It is distilled.
 - ii. There are many different types of distilled liquor, with various alcohol contents and flavors.
 - iii. There are various ways to be served distilled liquor, which can lead to confusion when trying to keep track of each serving.
 - 1. Mixed with other liquors
 - 2. Mixed with other liquids
 - 3. Straight
 - 4. Mixed stronger than recommended
8. The student will define blood alcohol concentration.
- a. The amount of alcohol in a person's bloodstream represented by a percentage;
 - b. Under 21- .02 percent or higher indicates use of alcohol; and
 - c. Over 21 -Legally under the influence can be .08 to .10 percent and in some cases, it can be lower.
9. The student will learn what constitutes a serving of alcohol.
- a. 12 ounce can of beer, 1.5 ounces of liquor, 5-ounce glass of wine all contain the same amount of alcohol.
10. The student will describe how alcohol is absorbed into the bloodstream.
- a. Alcohol is quickly and directly absorbed into the bloodstream without being digested;
 - b. Absorption can be slowed down if one has food in the stomach; and
 - c. Bloodstream carries alcohol throughout the body and behavior is affected when alcohol reaches the brain.
11. The student will identify the time required for alcohol to be absorbed into the bloodstream.
- a. Alcohol is quickly and directly absorbed into the bloodstream without being digested;
 - b. Alcohol is almost immediately absorbed through the stomach and small intestine directly into the blood stream and carried to other parts of the body;
 - c. Certain factors slow down the absorption of alcohol;
 - i. Body weight.
 - ii. Food in the stomach.
 - iii. Rate of consumption.
 - d. Once alcohol is absorbed into the bloodstream, the body will oxidize approximately one drink per hour.
 - i. Ninety percent (90%) occurs in the liver.
 - ii. Eight percent (8%) through breath.
 - iii. Two percent (2%) through sweat.
12. A person's body weight affects the percentage of alcohol in the blood. A heavier person has more body fluids, so a heavier person can drink more alcohol than a lighter person and still have a lower BAC.

13. The physiological makeup of the female versus a male subject with weight being equal will have the female with a significantly higher BAC than the male with both drinking the same amount of alcohol.
14. The elimination rate of alcohol is .015 to .018 percent per hour and this is equivalent to a standard drink. When the rate of consumption exceeds the elimination rate the brain begins to be sedated.
15. Standard drinks are considered to be one and one-half ounces of eighty proof distilled spirits, twelve ounces of beer and five ounces of wine. When the alcohol concentration in the alcoholic beverage exceeds the standard, the person will have a higher BAC.
16. Food in a person's stomach-will slow the absorption rate of alcohol down by about one-third of its actual rate. The alcohol will eventually get into the blood stream but not as fast as it would on an empty stomach.
17. Calculating the BAC or BAL will be done with the formulas found in the resources.
18. Experience with drinking alcohol has no effect on the blood alcohol concentration and the sedative effect on the central nervous system.
19. The body may become accommodating to the effects of alcohol on vision and balance but the alcohol still has control over one's judgment. Tolerance has no effect on the blood alcohol concentration and the sedative effect on the central nervous system.
20. The psychological mood that a person is in when drinking alcohol can be increased. For example, if a person is depressed, alcohol can increase this state of depression. There is no guarantee that alcohol will affect the person's psychological state the same way every time.
21. The student will explain how alcohol is removed from the body:
 - a. Breath, sweat, and urine will eliminate a small percentage of alcohol;
 - i. Combined they eliminate approximately 10 percent of the total.
 - ii. Tests to prove alcohol consumption are:
 1. Breath test
 2. Blood test
 3. Urinalysis
 - b. The liver processes the alcohol that is in the blood;
 - i. It metabolizes approximately 90 percent of the alcohol that is in the blood.
 - ii. BAC tests measure the percentage of alcohol that is in the blood.
22. The student will know the rate at which alcohol is removed from the body:
 - a. The enzyme alcohol dehydrogenase is responsible for starting the metabolism of alcohol into acetaldehyde, which is very toxic to the body;
 - b. The body can eliminate approximately 1 serving of alcohol (. 5 oz. of pure alcohol) in 1 hour and 15 minutes, and
 - c. Women take 10 to 15 minutes longer to eliminate alcohol because of the fat content of their bodies and less dehydrogenase to break the alcohol down.
23. The student will calculate the time to eliminate a given amount of alcohol according to weight, empty or full stomach, time and amount of alcohol ingested. Make a reference to a BAC chart.

24. The student will describe, based on the above, the wisdom of "if you drink, don't drive; if you drive, don't drink":
 - a. Impairment begins after the first drink;
 - i. .03 BAC impairs judgment and reaction time.
 - ii. .04 BAC impairs emergency response time.
 - iii. .05 BAC impairs tracking coordination, comprehension, eye movement.
 - b. Approximately 35 -40 percent of Pennsylvania traffic fatalities are alcohol-related;
 - c. Approximately 25 percent of the drivers between 16-20 who were killed in vehicle crashes had been drinking; and
 - d. There are approximately 13,000 alcohol-related collisions in Pennsylvania each year.
25. The various laws that Pennsylvania currently has in relation to young people (under the age of 21) and older people (21 years of age and older) and alcohol use are:
 - a. The State's DUI law;
 - b. The State's Zero Tolerance Law; and
 - c. The State's Underage Drinking Law.
26. The student will explain how killing someone while driving under the influence of alcohol will result in a mandatory jail sentence of three years:
 - a. Section 3732- Homicide by vehicle- DUI involved is considered a felony of the third degree, jail sentence of not less than three (3) years.
27. The student will define actions which could constitute underage drinking.
 - a. Lying about your age to obtain alcohol;
 - b. Purchasing, consuming, possessing, or transporting alcohol; and
 - c. Carrying a false identification card.
28. The student will outline the penalties for conviction of underage drinking:
 - a. First offense- ninety (90) days driving privilege suspension;
 - b. Second offense- one (1) year driving privilege suspension;
 - c. Third & subsequent offense - two (2) years driving privilege suspension;
 - d. A fine of up to \$500 and the police are required to notify your parents;
 - e. May be required to successfully complete program of alcohol education and counseling;
 - f. In addition to serving the suspension, a restoration fee must be paid before you are eligible to apply for your learner's permit;
 - g. Adults who provide alcohol to persons under 21, even their own children, will receive a mandatory fine of \$1,000 for the first offense and \$2,500 for second or subsequent offenses. This also applies to anyone who makes or sells false identification cards; and
 - h. A drug and alcohol evaluation.
29. The student will define "zero tolerance" as it applies to drivers under the age of twenty-one (21). The zero-tolerance law makes it illegal per se (in and of itself) for persons under the age of 21 to drive with any measurable amount of alcohol in their blood. The zero tolerance law reduced the blood alcohol content (BAC) required to charge minors (under 21) with driving under the influence (DUI) from .10 percent to .02 percent.

30. The student will list penalties assessed when a driver under the age of eighteen (18) is convicted of drunk driving:
- Up to one year driver's license suspension;
 - A drug and alcohol evaluation;
 - Participation in a state-approved Alcohol Highway Safety Program (if ordered);
 - Payment of fines, costs, and restitution;
 - Juvenile Court supervision or placement;
 - Chemical test refusal violations will result in an automatic one year suspension of driving privilege;
 - Your parents will be notified by the police of the arrest; and
 - A juvenile complaint will be filed within five days.
31. The student will enumerate the penalties assessed when a driver between the age of eighteen (18) to under twenty-one (21) is convicted of drunk driving:
- Accelerated Rehabilitative Disposition Program (ARD), if qualifications are met;
 - Incarceration for forty-eight (48) hours if the defendant does not accept or qualify for ARD;
 - Up to one year driver's license suspension;
 - A drug and alcohol evaluation;
 - Participation in a state approved Alcohol Highway Safety Program (if ordered);
 - Payment of fines, costs, and restitution; and
 - Chemical test refusal violations will result in an automatic one-year suspension of driving privilege.
32. The student will explain the significance of .10 percent blood alcohol concentration applied to a driver twenty-one years of age or older:
- The Commonwealth need only to prove the defendant drove a vehicle when the amount of alcohol in the blood was .10 percent or greater;
 - A BAC of .10% means the blood contains one tenth of one percent of alcohol or about one drop of alcohol in every 1000 drops of blood or 15 drops of alcohol in a quart of blood;
 - BAC is usually measured by a chemical test of breath with a breath analysis instrument; and
 - BAC can also be measured by a blood test and urine test.
33. The student will list the penalties for a driver twenty- one years of age or older who is convicted of drunk driving:
- For the first-time offender, there is a minimum fine of \$300 and you will spend a mandatory 48 consecutive hours in jail. Every conviction carries with it at least a one year license suspension and imprisonment as follows:
 - 2nd conviction within 7 years - 30 days
 - 3rd conviction within 7 years - 90 days
 - 4th conviction within 7 years - 1 year

- b. Accelerated Rehabilitation Disposition (if eligible);
 - c. Drug alcohol evaluation;
 - d. Completion of Alcohol Highway Safety Program;
 - e. Conviction of DUI and homicide is a Felony 3 and carries a mandatory minimum sentence of 3 years imprisonment; and
 - f. DUI charges can be brought in from another state.
34. The student will explain why multiple tests may be administered to drivers who are believed to be impaired by alcohol or other drugs:
- a. May be asked to take one or all three of the chemical tests;
 - b. Blood and urine tests will find drugs and illegal substances;
 - c. Breath test is for alcohol.
 - d. Driver could be showing signs of a drunk driver but may be under the influence of a controlled substance.
35. The student will describe the significance of a driver twenty-one years of age or older and a BAC of .05 percent to .09 percent.
36. The student will describe "implied consent" and the penalty for not submitting to an appropriate test(s):
- a. When any person drives or is in actual physical control of the movement of a motor vehicle, there exists a condition of implied consent to take one or more chemical tests of breath, blood, or urine to determine alcohol or controlled substance content. If you refuse to take the test, your license will be suspended for one (1) year and your refusal can be used as evidence in a DUI trial; and
 - b. Police must have a reasonable suspicion of DUI prior to arrest. They may require the driver to submit to a pre-arrest breath test on an approved device to determine if a DUI arrest should be made.
37. The student will describe the relationship between the conviction of drunk driving and increased insurance costs:
- a. The greater the BAC, the greater the chance of being in an accident;
 - b. Potential for cancellation of car insurance policies; and
 - c. Increased costs for all who purchase automobile insurance.
38. The driver of a motor vehicle who is impaired will demonstrate certain characteristics because of the physiological effects of alcohol on the body. Some of the driving characteristics are:
- a. Short sight distance will cause the driver to steer toward the center line or lane line that he/she is focusing on;
 - b. Short sight distance and inattentiveness will cause the driver to be erratic in their speed control and position adjustment; and
 - c. Inattentiveness will cause a driver to miss regulatory signs and signals.
39. When confronting another driver who is obviously impaired, a driver can initiate some of the following actions:
- a. If following a suspected impaired driver, increase the frontal space cushion, identify the license plate and characteristics of the motor vehicle, and report this to the authorities as soon as possible; and

- b. If meeting an oncoming suspected impaired driver, reduce speed and move as far right as possible in the respective lane. Try to avoid a sudden movement which could startle the impaired driver.
40. The student will analyze the risk of choosing to ride with a driver who has been drinking:
- a. Statistics show that about one-half of all highway deaths involve alcohol.,
 - b. The types of injuries that occur in motor vehicle crashes are devastating to the lives of victims and their families; and
 - c. Death and injury to passengers in a motor vehicle crash is many times related to a driver who had been drinking.
41. The student will list impairment characteristics to identify prior to riding with a driver who has been drinking:
- a. Fine motor impairment:
 - i. Unable to write name clearly.
 - ii. Unable to button coat, hold or use the car keys.
 - b. Gross motor impairment:
 - i. Movement of arms are exaggerated and uncoordinated.
 - ii. Staggering while walking or swaying while standing.
 - iii. Reduced reaction time.
 - c. Speech impairment:
 - i. Slurring of words.
 - ii. Using words out of context.
 - d. Emotional and behavioral changes:
 - i. Becoming loud or very quiet.
 - ii. Becoming belligerent or passive.
 - iii. Becoming a risk taker.
 - 1. Inhibitions are reduced - may think they are superman/woman
 - 2. May become more sexually permissive
 - iv. Memory problems.
 - e. Visual motor impairment:
 - i. Reaction time is slowed.
 - ii. May be dizzy or disoriented.
 - f. Other physical signs:
 - i. Vomiting.
 - ii. Increased urine elimination.
 - iii. Delirious.
 - iv. Unconscious.
42. The student will explain responsibilities to an individual who is obviously intoxicated and wishes to drive:
- a. Law:
 - i. Underage- Zero Tolerance Law in Pennsylvania- .02.
 - ii. Of age- .06 BAC or higher

- b. Moral/Ethical/Friendship:
 - i. Can you help in preventing loss of life or injury?
 - ii. Could you live with the idea that you did nothing?
 - iii. Would you rather that the person be upset with you than injured or dead?
 - iv. Are you strong enough mentally/physically to do anything to stop them from driving?
 - v. Are you willing to get into some trouble to save your friend?
43. The student will be able to identify alternatives one may pursue to avoid driving after drinking alcohol. **This is not to promote underage drinking!**
- a. Alternative methods of travel;
 - i. Call a taxi.
 - ii. Take a bus.
 - iii. Walk.
 - iv. Designated driver.
 - v. Call a friend.
 - vi. Call your parents.
 - b. Do not go anywhere; and
 - i. Stay at home.
 - ii. Plan sleepovers.
 - c. Take keys of the drivers
44. Identify common over the counter drugs which could present a problem in performing the driving task:
- a. Nonprescription drugs- aspirin, cold pills, cough syrup and sleep aids. Read the labels carefully before taking any drug.
45. Identify common abused drugs and what effect they can have on one's driving performance:
- a. Stimulants - speed up the central nervous system, impairs judgment, distorts reality, and hinders concentration;
 - i. Cocaine and Narcotics
 - b. Depressants - slow down the central nervous system make thinking difficult, cause depression, slow reaction time, impair coordination and affect sight; and
 - i. Barbiturates and Tranquilizers
 - c. Hallucinogens - affect the way a user sees objects. They can cause confusion, impair judgment, and reaction time.
 - i. Marijuana, LSD, and PCP
46. Explain the synergistic effect in relation to drugs:
- a. The effects of taking two or more drugs at the same time. The combined effect of the two drugs is greater than the sum of the two effects separately. Anytime you combine another drug with alcohol, the effects may be different from those expected if either drug is taken alone. This combination is harmful and can produce unexpected results.
47. Explain how prescription drugs affect a person's ability to perform the driving task:
- a. Can hinder one's driving ability by reducing your level of alertness or ability to perform complex tasks; and

- b. Be sure to follow directions. This can limit dangerous and undesirable side effects.
48. To determine how huffing or sniffing certain inhalants affect the driving performance, please check with resources.

Resources

Formula

An excellent resource to determine a person's Blood Alcohol Level (BAL) or Blood Alcohol Content (BAC) or the Volume of Alcoholic Beverage that a person consumed is the Widmark Formula. The following formulas were developed using the Widmark Formula and they are a valid and reliable measure of alcohol use.

The first formula is used to determine a person's BAL:

$$\text{BAL or BAC} = (\text{beverage} * \text{volume}) / \text{weight}$$

BAL = Blood Alcohol Level

Beverage = Type of beverage that person consumed. Use the table for type of beverage and male or female.

Volume = This is the ounces of alcoholic beverage that the person has consumed, e.g., three 12-ounce cans of beer is 36 ounces; two 4-ounce glasses of wine is 8 ounces; two mixed drinks of 80 proof distilled spirits with 2 ounces in each drink is 4 ounces of 80 proof

Weight = Person's weight in pounds

Elimination Rate = a person's body will eliminate between .015 and .018 alcohol in a one-hour period. This is a constant number or value.

Beverage Table

Male	Beverage	Female
3.78	100 proof	4.67
3.25	86 proof	4.02
3.02	80 proof	3.74
.93	Wine	1.14
.31	Beer	.38

These numbers are constant, and the female has a higher point value than the male. The reason for this is the difference in the physiological make-up of the female versus a male subject with weight being equal. A female and male subject of equal weight, drinking the same amount of alcoholic beverage, the female will have a higher BAL.

Sample Problem

What is the Blood Alcohol Level (BAL) of a 180-pound male who drinks five 12-ounce cans of beer over a three-hour period?

$$\text{BAL} = (\text{Beverage } (.31) * \text{Volume } (160 \text{ oz}))/180 = 18.6/180 = .103$$

After finding the BAL, you must then subtract the alcohol eliminated from the body during the three-hour period.

$$3 \text{ hours} * .015 \text{ or } .018 = .045 \text{ or } .054$$

$$\text{BAL} = .103 - .045 \text{ or } .054 = .058 \text{ or } .049$$

This subject's BAL at the end of a three-hour period is between a .049 and .058.

Sample Problem

A 130-pound female subject is driving a motor vehicle and it is involved in a collision. The police officer detects that the subject has been drinking alcohol and asks her to submit to an alcohol test. The test is given at 8 p.m. and the subject records a .063 BAL. The subject said she stopped after work at 5 p.m. and had a couple of beers. How many ounces of beer did this 130-pound female subject consume?

Her BAL at 8 p.m. was .063 and she started to drink at 5 p.m. This allowed her body to get rid of alcohol over a three-hour period. (.015 or .018 * 3 hours = .045 or .054) Therefore, she eliminated between .045 and .054 BAL from 5-8 p.m.

$$\text{Volume} = (\text{Weight } (130 \text{ pounds}) * \text{BAL } (.036 + .045 \text{ or } .054))/\text{Type of beverage } (.38)$$

$$\text{Volume} = (130 * .108 \text{ or } .117)/.38 = (14.04 \text{ or } 15.21)/.38 = 37 \text{ or } 40 \text{ ounces.}$$

The volume of beer that the person consumed was between 37 and 40 ounces

1. Textbooks
 - a. Drive Right
 - b. Responsible Driving
 - c. How to Drive
 - d. License to Drive
 - e. Drugs, Society and Human Behavior; 4th Edition, Mosby, 1987
2. Instructional Programs
 - a. If You Drive, What About Drinking? AAA
3. AAA Videos and Publications
 - a. Booklet- You, Alcohol, Other Drugs and Driving
 - b. Video- Just Another Friday Night
4. Pennsylvania Liquor Control Board
 - a. The Responsible Parent - How to Talk to your Kids About Alcohol and the Law, Pennsylvania Liquor Control Board (1993)

- b. Under 21- Zero Tolerance, The Pennsylvania Liquor Control Board (1996)
 - c. Know the Facts- Underage Drinking- Don't, Pennsylvania Liquor Control Board (1995)
 - d. Underage Drinking-- It's the Law, Pennsylvania Liquor Control Board (1995)
 - e. What's Your IQ on DUI? Pennsylvania Liquor Control Board (1995)
 - f. The Truth About Alcohol
 - g. Straight Talk for Teens About Alcohol
5. Other Resources
- a. Pennsylvania Vehicle Code (current)
 - b. Pennsylvania Driver's Manual (current)
 - c. Pamphlet, Every Drop Counts, Nationwide Insurance, et al
 - d. The Truth About Drinking, AIMS video
 - e. Sentenced for Life, Fox Hills Video. Volkswagen Unites States (1987)
 - f. The Game of Your Life, General Motors Corporation (1988)
 - g. License to Kill, Turning Points. ABC (1996)
 - h. Fatal Vision Impaired Vision Simulator
 - i. Cruisin', Not Boozin', The Bryn Mawr Rehabilitation Hospital in Malvern, PA.
 - j. Video- "A Pathologist's View of the Drunk Driver" (Paul Ehrhart, Methacton High School)
 - k. Computer program "The Party" (Paul Ehrhart, Methacton High School)
6. Stop- Think and Go Decision-Making Case Studies
- a. You are a sophomore member of a high school varsity sports team. Certain senior members of the team have met as a group socially many times during the past two years where there has been alcohol involved. The group has invited you to join them after the game on Friday night.

Your parents have given you the "lecture" about the hazards of alcohol, sex and risk taking in the car, so you know where they stand on the issue. The coach has also explained to the team the school policy about alcohol and tobacco use. The policy states that if you are caught drinking alcohol, smoking cigarettes or chewing tobacco you will be removed from the team for the remainder of the season.

This is your chance to be accepted by the older players on the team. The party will be held at the home of one of the players whose parents permit drinking in the house if the kids stay overnight. The house is located in a rural area of your school district and is not patrolled by police. Do you go to the party?

How to Use the Decision-Making Model:

1. Put the students into groups or do this as a whole class exercise.
2. Read the situation to the groups/class.
3. Have students/groups come up with the answer to the situation and explain why they feel their answer is a good answer.
4. Go back over the decision, using model to review how to make a decision.

5. Have students/groups justify their answer using the model.
6. Have the students/groups share their answers with the entire class.
7. If you have a newspaper/magazine article that is similar to this scenario read it to the class to make the point clearer to the students.

Some examples of answers that may be presented by the students:

Stop

1. Going to the party without getting caught.
2. Going to the party and not drinking.
3. Stating publicly that I don't agree with underage drinking and that I don't want to be a part of illegal behavior (and still be accepted) (or not).
4. Following family/team rules.

Think

Right /wrong

1. It is illegal.
2. Others do it and get away with it.
3. One drink won't hurt me.
4. What are the chances of being caught?
5. May not make friends.
6. Maybe these guys aren't worth having as friends.

Responsibility

1. To parents/team.
2. It is illegal.
3. Need to set trend for self and others.

And so on...

- b. You have just completed hockey practice and your brother arrives to pick you up. He hates this task and you know it. The ice rink is several miles from home. Your father is working late and your mother is home with your little brother and sister. As you are about to get into the car, you smell alcohol. You notice your brother is slurring his words and seems to be intoxicated. Your brother insists he is able to drive.
- c. Your seventeen-year-old sister has a date with her boyfriend. When he arrives, you realize he seems to have been drinking. You tell your sister that her date is slurring his words and really seems incoherent. She tells you to "mind your own business." You know they are going to a party. Your parents are next door with friends.
- d. You have been invited to go out with four of your friends for a fun-filled evening. While you are with your friends, you notice that the driver and two of the other

passengers have elected to drink some beer. After two hours at one location, some of the group including the driver, decide that everyone should go to another party.

- e. You are watching three children whose parents are at a party. When the parents arrive, they offer to take you home. This couple is very good friends with your parents. You notice several signs that the couple has had too many drinks and should not even have driven home. You are saving all your babysitting money for a trip to Europe this summer.

Financial Responsibility

Episode Justification

Motor vehicle insurance protects the owner/operator from financial losses that result from motor vehicle collisions, especially if the owner/operator is the primary cause of the collision. Insurance is a part of everyday life and this is very true with motor vehicle insurance. It is a legal agreement between the policyholder and the insurance company. While the choice of insurance companies and options appear simple, the consequences can result in significant financial hardships. Because of this, it is imperative that students become knowledgeable consumers of automotive insurance and the perils of not being adequately insured. Economic loss due to reportable traffic crashes in Pennsylvania exceeds \$11 billion annually. Sixteen-year-old drivers in Pennsylvania were involved in 13 percent of all reported crashes.

Episode Objectives

1. Pennsylvania's financial responsibility for owning and operating a motor vehicle.
2. Required and optional insurance coverage available for motorists.
3. Factors that affect the cost of automotive insurance premiums.
4. Aware of when to file and how to complete an accident report.

Performance Objectives

The student will:

- 1.1. Identify and explain the mandatory insurance coverage that all motorists in Pennsylvania are required to have on their respective motor vehicle;
- 1.2. Describe the two types of liability insurance;
- 1.3. Explain the penalty for non-compliance;
- 1.4. Explain the licensing fee structure and its requirements;
- 2.1. Identify and explain the various options available with automotive insurance;
- 2.2. Explain assigned-risk insurance;
- 2.3. Explain the tort option;
- 3.1. List and explain the variables which determine automotive insurance premiums;
- 3.2. Identify and explain the different deductibles and their effect on the insurance premiums;
- 4.1. Identify the types of motor vehicle crashes that are required to be reported to the Department of Transportation; and
- 4.2. Identify and describe the information needed to complete an accident report.

Content

1. Pennsylvania has a compulsory liability insurance law and the minimum or required dollar amounts are \$15,000/\$30,000/\$5,000. This means if you are responsible for a motor vehicle crash a maximum of \$15,000 will be paid for death or injury of one person, a maximum of \$30,000 for death or injury of more than one person, and a maximum of \$5,000 for property damage. Proof of coverage is required at all times.
2. The two types of liability insurance are:
 - a. Bodily Injury- This will protect the driver if he/she causes injury or death to another person or persons in a motor vehicle collision. It also covers legal fees, court costs, lost wages, and additional non-economic losses.
 - b. Property Damage- This will protect the driver if he/she causes damage to another person's property in a motor vehicle collision.
3. The penalty for non-compliance of Pennsylvania's compulsory liability insurance law is a \$300 fine.
4. Pennsylvania's licensing fee structure and its requirements are:
 - a. The initial Class C learner's permit and license fee for a person under the age of 65 is \$29.00. This fee includes:
 - i. License fee of \$20.00
 - ii. Permit fee of \$5.00
 - iii. Photo fee of \$4.00
 - b. To initiate this process, the following requirements need to be met:
 - i. Complete the application form;
 - ii. Complete a medical examination;
 - iii. Parental consent under the age of 18; and
 - iv. Take three tests- vision, knowledge and road.
 - c. The four-year Class C license renewal for drivers under the age of 65 is \$24.00
5. The various options that are available with Pennsylvania's automotive insurance are:
 - a. Uninsured or Underinsured- Another driver who is responsible for a motor vehicle collision might not have insurance or not have enough insurance. This coverage will allow the victim to make a claim for compensation against his/her insurance company to cover costs that the errant driver cannot pay.
 - b. Collision- this coverage pays for damages to your vehicle if you are responsible for a collision. It will also cover repair costs if your vehicle is damaged in a parking lot or parking space on street.
 - c. Comprehensive- This coverage pays for damages to your vehicle from theft, vandalism, fire, explosion, natural disaster or riot.
 - d. First Party- This coverage pays for medical expenses of the insured and also passengers in the insured vehicle. This is paid without regard to who was at fault.
 - e. First Party Income Loss -This coverage pays a percentage of the actual loss of gross income for the injured insured. This is paid without regard to who was at fault.

6. Assigned-risk insurance in Pennsylvania refers to a driver who has been dropped by his/her insurance company because of a serious collision or several traffic violations. This driver might not be able to get insurance at standard rates from other companies. This high-risk driver must buy an assigned-risk insurance policy at a high premium for minimum liability coverage. A driver can return to normal insurance by demonstrating several years of collision and violation free driving.
7. Every consumer of auto insurance must select a tort option; limited tort or full tort. Tort Jaw pertains to legal actions for civil wrongdoing. The most common example is a claim for negligence arising out of a car crash. If you suffer injury due to the negligence of another, the law gives you the right to claim compensation in tort against the negligent party. Only full tort gives you full protection. This option gives you the ability to maintain an unrestricted right for you and the members of your family to seek compensation for your injuries caused by the negligence of others. Limited tort will provide a discount in your premium. However, with limited tort, you may have difficulty proving that you have suffered serious impairment of body function or permanent serious disfigurement.
8. Insurance companies rely on statistics to determine their rates. The statistics indicate the likelihood that persons of certain age, sex or marital status will be involved in a collision. They also indicate the likelihood of certain types of motor vehicles being involved in a collision. The following factors determine insurance rates:
 - a. Age;
 - b. Driving record (collisions and violations);
 - c. Miles driven per year;
 - d. If you drive to work and distance to work;
 - e. Where you live;
 - f. Coverage limits;
 - g. Type of motor vehicle;
 - h. Value of motor vehicle;
 - i. Marital status;
 - j. Driver education;
 - k. Grades of a student;
 - l. Multiple motor vehicles; and
 - m. Safety features in the motor vehicle(s).
9. Deductibles are what the insured must first pay before the insurance company starts to pay, e.g., a \$500 collision deductible means that the insured must pay the initial \$500 and the insurance company will then pay the balance. The higher the deductibles, the lower the insurance premiums.
10. The Pennsylvania Department of Transportation requires all motor vehicle collisions that involve either death and/or injury, and one or more of the involved vehicles must be towed, to be reported immediately to the police. If police do not investigate, then the collision must be reported within five days to the Department.
11. The information needed to complete an accident report include but is not limited to:
 - a. Name, driver license number, address, phone number, insurance company of other driver;
 - b. Name, address, telephone number of those injured;

- c. Name, address, telephone number of any witnesses;
- d. Year and make of other vehicle and license number;
- e. Date, time, visibility condition, weather condition and location of collision;
- f. Brief description of how collision occurred and the results of the collision (personal injury/property damage); and
- g. Diagram of collision scene which shows position of vehicles at time of contact and other highway features with traffic controls identified.

Resources

- 1. Textbooks
 - a. Drive Right
 - b. Responsible Driving
 - c. How to Drive
 - d. License to Drive
- 2. References
 - a. Pennsylvania Uniform Vehicle Code (Current)
 - b. Pennsylvania Driving Manual (Current)
 - c. AAA Digest of Motor Laws
 - d. Insurance Companies
- 3. Stop - Think and Go Decision-Making Case Study
 - a. A young driver in his/her own car has several friends as passengers and is involved in a collision with an unattended parked car in a shopping mall parking lot. The friends urge the driver to quickly leave and not do anything because his/her insurance rates will increase if the crash is reported.

Trip Planning

Episode Justification

When one thinks of trip planning, the thought is usually directed toward a long-distance trip. When this occurs, specific destinations and routes are planned ahead of time, and the preparation of the vehicle is also included. Vehicle preparation and detailed trip planning help to ensure a safe and efficient trip. Planning ahead helps eliminate unanticipated interruptions. The same care and thought should also be used for short trips. Driver and vehicle preparation prior to any trip is essential for ensuring an uneventful trip.

Episode Objectives

1. Trip planning that goes into short trips;
2. Trip planning that goes into long trips;
3. Understanding and using a road map;
4. Understanding the difficulties associated with trailers and recreational vehicles; and
5. Awareness of the new technology that is available in today's motor vehicles.

Performance Objectives

The student will:

- 1.1. List examples of short trips;
- 1.2. Explain the type of vehicle preparation that needs to occur for a safe and efficient short trip;
- 1.3. Identify the type of preparation that a driver should consistently use for a safe and efficient short trip;
- 2.1. Define the term long trip;
- 2.2. Give examples of long trips in a motor vehicle that he/she has experienced;
- 2.3. List the type of vehicle preparation necessary to ensure a safe and efficient long trip;
- 2.4. Explain the type of driver preparation necessary to ensure a safe and efficient long trip;
- 3.1. Demonstrate the ability of determining north, south, east and west on a state highway map;
- 3.2. Explain the numbering and its meaning for the interstate highway system;
- 3.3. Identify the difference between US highway routes and state highway routes;
- 3.4. Demonstrate the ability to locate selected cities and towns on a road map;
- 3.5. Demonstrate the ability to determine mileage between specified locations;
- 3.6. Explain the meaning of the various symbols that are used on highway maps;
- 3.7. Plan a long trip that will include breaks, fuel stops, meal stops and lodging to calculate both the time and costs associated with the planned trip;
- 4.1. Identify the disadvantages drivers encounter when pulling a recreational trailer or driving a recreational vehicle;
- 4.2. Identify visual clues that help to determine a high or low risk operator of a trailer or recreational vehicle;

- 5.1. Identify and use computer generated programs that are designed for trip planning; and
- 5.2. Identify and explain other technology that is available in motor vehicles that increases the safety and efficiency of the motor vehicle in relation to trip planning.

Content

1. Short trips are any trip within a three-hour radius of one's home base. It can be one's everyday driving area or a specific trip for a single purpose.
2. The vehicle checks for a safe and efficient short trip should include but not be limited to:
 - a. Weekly check of tires and spare;
 - b. Daily check of fuel; and
 - c. Fluid level checks when filling vehicle with fuel (engine, transmission, brakes, steering, windshield, radiator).
3. The types of driver preparations that help to ensure a safe and efficient short trip include but are not limited to:
 - a. Sufficient amount of sleep in a 24-hour period;
 - b. Avoid medications whenever possible;
 - c. Avoid alcohol and other drugs;
 - d. Minimize distractions in the motor vehicle;
 - e. Know beforehand the selected route(s);
 - f. Allow sufficient time to arrive at "destination; and
 - g. Maximize the comfort systems within the motor vehicle.
4. A long trip can be defined in excess of three hours and typically is a destination that is not normally traveled by the driver.
5. Most long trips are usually associated with but not limited to:
 - a. Vacations;
 - b. Family functions;
 - c. Holidays; and
 - d. School-related functions.
6. The vehicle checks for a safe and efficient long trip would include but not be limited to:
 - a. Check tires (includes spare);
 - b. Check fluid levels (engine oil, transmission, brakes, steering, windshield, radiator);
 - c. Check hoses and belts;
 - d. Check all lights;
 - e. Condition of battery;
 - f. Emergency equipment in vehicle; and
 - g. Stow luggage and supplies in a secure manner.
7. The types of driver preparations that help to ensure a safe and efficient long trip include but are not limited to:
 - a. Sufficient amount of sleep in a 24-hour period prior to the trip;
 - b. Plan the selected route(s) to one's destination and carry road maps if detours need to be taken;
 - c. Plan a rest stop approximately every two hours;
 - d. Plan driving times (start, breaks, metropolitan areas, final destination);

- e. Avoid alcohol and other drugs;
 - f. Avoid or minimize medications; and
 - g. Maximize the comfort systems in the motor vehicle.
8. Using a state highway map will always have the top of the map as north, bottom as south, right as east and left as west.
 9. When using a Global Positioning Satellite (GPS) system, direction of travel should point towards the top of the device to provide a better understanding of position as it relates to travel.
 10. The numbering of the interstate highway systems involves the following:
 - a. Two digit, even number, means that the highway runs east and west, e.g., Interstate 70, Interstate 80;
 - b. Two digit, odd number, means that the highway runs north and south, e.g., Interstate 79, Interstate 81, Interstate 95;
 - c. Three-digit interstate numbers have one of two meanings:
 - i. The first number is even, then the loop around the metropolitan area will tie back into the two-digit interstate, e.g., Interstate 279, Interstate 283, and Interstate 295.
 - ii. If the first number is odd, then the loop leaves the two-digit interstate, but it doesn't tie back into it, e.g., Interstate 376, Interstate 380.
 - d. If the interstate sign is green and white and indicates business, then this section of the interstate highway is not controlled access and there is cross traffic. This business interstate will eventually tie back into the original interstate, e.g., business Interstate 83;
 - e. The mile markers and interchange numbers always begin on the western border or the southern border of the state; and
 - f. The numbering system for the interstate highways always start with the lowest in the western or southern part of the United States.
 11. US highway routes are always designated with the federal highway shield, and they run between states. They also use a numbering system comparable to the interstate numbering system. State highway routes are always designated with a silhouette of the state, the state name or a symbol, e.g., Pennsylvania's symbol is the keystone. State highway route numbers only run within the state and they will change when going into the neighboring state. State highway route numbers are not comparable to the federal highway route numbers, e.g., odd and even numbers do not always mean the directions (north, south, east, and west) found with the federal or US highway numbers.
 12. The students need to use the letter and number coordinates on a highway map to locate specified locations.
 13. The students should learn how to use the mileage chart and be able to accumulate the mileage between the various reference points.
 14. On all road maps there is an inset that shows and explains how to read the respective highway map. These will vary, and students need to be aware of this.

15. Planning a long trip can be an individual or small group activity and should be planned by the teacher.
16. The only advantage associated with driving or pulling a recreational vehicle is the driver generally sits higher and has a higher sight distance. The disadvantages associated with these vehicles are:
 - a. Greater braking distance;
 - b. Longer distances needed to go from zero to selected speed;
 - c. Larger space needed for maneuvering;
 - d. Higher clearance space needed;
 - e. Crosswinds will affect control; and
 - f. Visibility to the rear is reduced.
17. Some visual clues that might indicate the operator of a recreational vehicle to be a high-risk driver are:
 - a. Not allowing sufficient following distance with vehicle in front;
 - b. Continuously driving close to either the center line or one of the respective lane lines;
 - c. Driving in excess of the posted speed limit;
 - d. Driving in excess of the recommended speed in certain locations, e.g., curves, ramps;
 - e. Continuously maintaining a speed when there is a continual swaying of the recreational vehicle from side to side; and
 - f. Not making frequent mirror checks to monitor other traffic to the rear or alongside.
18. Students need to be aware of the various computer sources that are available for trip planning. This can include specific programs and the internet.
19. Some of the new technology available in motor vehicles would include but not limited to:
 - a. Car Navigation Systems:
 - i. Assist driver in locating a destination.
 - ii. Provide information about local traffic conditions.
 - b. Traffic Message Channels:
 - i. Specialized channels encoded in radio signals.
 - ii. Provide special broadcasts about traffic conditions.
 - c. Emergency Response Technology:
 - i. Relay information that crash has occurred and identifies exact location.
 - ii. If airbag is deployed, EMS is notified in that area.
 - d. Signal to driver when a system is outside the normal range of operation, e.g., fuel level, brake fluid level, engine temperature, etc.; and
 - e. Electronic toll roads.

Resources

1. Textbooks
 - a. Drive Right
 - b. Responsible Driving
 - c. How to Drive

- d. License to Drive
- 2. Miscellaneous
 - a. Motor Vehicle Manufacturers
 - b. Automotive Dealerships
- 3. Internet
 - a. Planning Your Summer Road Trip
 - b. Pick a Destination and Map It. AOL Travel Keyword Mapping.
 - c. [Technology and driving: The Future Technology and Driving](#)
 - d. [Microsoft Streets and Trips World Wide Website](#)
 - e. [National Geographic Trip Planner](#)
 - f. [Rand McNally Trip Maps](#)
 - g. Google Maps
 - h. Waze App.
 - i. Siri for Apple products
- 4. Computer Programs
 - a. Microsoft Expedia Streets and Trips 2000
 - b. National Geographic Trip Planner Platinum 2000
 - c. Rand McNally Street Finder Deluxe 1999 Edition
 - d. Rand McNally Trip Maps 1999 Edition
- 5. Stop- Think and Go Decision-Making Case Study
 - a. You are driving a recreational vehicle on a camping trip and you are traveling on a controlled access highway. You have just missed your exit and you are able to pull over onto the shoulder of the highway approximately 500 feet past the exit. Should you continue on to the next interchange or should you back on the shoulder to get to the exit ramp? The following are some options for discussion:
 - i. The next exit is 10 miles
 - ii. There is a heavy volume of traffic
 - iii. There is minimal traffic.
 - iv. The shoulder is a wide area
 - v. The shoulder has minimal space with guardrail
 - vi. You are driving a car and not an RV

Buying/Maintaining a Car

Episode Justification

Buying a new or used motor vehicle is something that every driver will do sooner or later. There is a great deal tomorrow regarding the responsibilities of owning and operating a motor vehicle. Before making a decision on the type of motor vehicle to purchase, many variables need to be examined and evaluated. Vehicle maintenance is one of these variables, and this needs to be thoroughly understood by the consumer. Next to real estate, owning and operating a motor vehicle is the second greatest expenditure of funds that the consumer will encounter.

Episode Objectives

1. Need and responsibilities of owning a motor vehicle;
2. Selecting a motor vehicle;
3. Financing a motor vehicle; and
4. Costs of maintaining a motor vehicle.

Performance Objectives

The student will:

- 1.1. List reasons for requiring the purchase of a motor vehicle;
- 1.2. List reasons for negating the purchase of a motor vehicle;
- 1.3. Identify the responsibilities of owning a motor vehicle;
- 1.4. List the fixed costs and the variable costs associated with owning and operating a motor vehicle;
- 2.1. List the pros and cons of buying a new motor vehicle;
- 2.2. List the pros and cons of buying a used motor vehicle;
- 2.3. Explain the process for selecting a specific type of motor vehicle;
- 3.1. Identify selective funding sources for financing a motor vehicle;
- 3.2. Budget the payments on a motor vehicle for a selected period of time;
- 4.1. Identify the annual costs of maintaining a motor vehicle;
- 4.2. Describe the steps that a driver should take in relation to vehicle maintenance each time before and after the vehicle is started;
- 4.3. Explain the preventive maintenance checks that should be done every time fuel is purchased;
- 4.4. Identify the preventive maintenance checks that should be done at least once per month;
- 4.5. Describe the vehicle service schedule and when the various services should be done;
- 4.6. Identify methods of finding a qualified garage and mechanic to work on one's motor vehicle;
- 4.7. Describe Pennsylvania's annual vehicle safety inspection requirement;
- 4.8. Describe Pennsylvania's annual vehicle emission inspection requirement;
- 4.9. Calculate miles per gallon of fuel; and
- 4.10. Identify ways of improving fuel efficiency when operating a motor vehicle.

Content

1. Reasons for wanting to purchase a motor vehicle will differ between a young person and an older person. Some of the reasons that a young person might have in wanting to own their own motor vehicle might include:
 - a. Motor vehicles make you more independent;
 - b. Motor vehicles save you time when wanting to get from one place to another;
 - c. Owning your own motor vehicle will make you feel more grown up; and
 - d. Using your own motor vehicle to travel about is enjoyable.
2. Questions that need to be answered before deciding to purchase or not purchase a motor vehicle are:
 - a. How close do you live to the places that you normally frequent?
 - b. How do you currently get to these places?
 - c. How convenient is public transportation?
 - d. Is there a family car currently available for your use?
3. The responsibilities of owning a motor vehicle would include:
 - a. Being able to purchase and maintain a motor vehicle financially;
 - b. Need to change one's schedule regarding the need to earn money to purchase and maintain the motor vehicle;
 - c. Being able to distinguish between your wants and your needs regarding car ownership; and
 - d. Being able to manage the risk involved with operating a motor vehicle so that loss does not occur for oneself or others.
4. There are both fixed costs and variable costs associated with owning and operating a motor vehicle. The fixed costs associated with owning and operating a motor vehicle are:
 - a. The purchase price of the vehicle;
 - b. The sales tax on the purchase price;
 - c. Registration fee (annual);
 - d. Insurance (annual or semi-annual); and
 - e. Financing if not paying cash and this would include principal, interest and insurance over a set period of time.

The variable costs associated with owning and operating a motor vehicle are:

 - a. Fuel costs
 - b. Maintenance which includes: oil, tires, brakes, belts and hoses, lubricating and cooling fluids, exhaust system, safety and emission inspections, etc.;
 - c. Parking fees; and
 - d. Toll fees.
5. The positive reasons for buying a new motor vehicle would include but not be limited to:
 - a. The ability to get all of the features that you desire with a new vehicle;
 - b. The full warranty associated with a new vehicle;
 - c. Less risk of having mechanical problems; and
 - d. The ability to select a vehicle for your needs.

The negative factors associated with buying a new motor vehicle would include but not be limited to:

- a. The purchase price of a new vehicle;
 - b. The rate of depreciation; and
 - c. Insurance rates are usually higher.
6. The positive reasons for buying a used motor vehicle would include but not be limited to:
- a. The purchase price of a used vehicle will be much less than the price of a new vehicle; and
 - b. The insurance rates are usually lower.

The negative factors associated with buying a used vehicle would include but not be limited to:

- a. Little to no warranty on a used vehicle;
 - b. Greater risk of having mechanical problems;
 - c. Not being able to select all of the features that might be desired or needed; and
 - d. Maintenance costs are sooner and more costly.
7. Selecting a specific type of motor vehicle should involve many different factors. Some of the factors that need to be considered in selecting a specific type of vehicle would include:
- a. The safety features;
 - b. Advanced warning features;
 - c. The comfort features;
 - d. The fuel efficiency;
 - e. The number of passengers generally carried;
 - f. The age of the passengers;
 - g. The number of miles that the vehicle will be used in a period of time;
 - h. The manner in which the vehicle will be used, e.g., towing, hauling, etc.; and
 - i. The reliability of the make and model.
8. If you are a full-time high school student, you cannot obtain financing on your own, you must have an adult be responsible for repayment. If you are 18 years of age and employed full-time, finding sources for financing a motor vehicle could be:
- a. Banks;
 - b. Credit unions;
 - c. Finance companies; and
 - d. Automobile dealer (new vehicles).
9. The student should select the type of vehicle he desires to purchase and identify the costs associated with the desired vehicle from the publication titled NADA Guide (National Auto Dealers Association Guide) or the internet. The student should then identify the other costs which include: sales tax, vehicle registration and dealer fees. After determining total cost, the student should then identify a lending source with its interest rate and number of months for repayment. Using a set dollar amount for down payment, the student should then determine the monthly payment needed for principal and interest.

10. The annual costs for maintaining a motor vehicle excluding monthly finance payments applicable are:
 - a. Insurance premiums;
 - b. Fuel costs;
 - c. Safety inspection;
 - d. Emission inspection;
 - e. Vehicle registration; and
 - f. Vehicle service costs.
11. There are selective procedures that one should do prior to starting a vehicle that relate to vehicle maintenance and they are:
 - a. Before entering the vehicle, do a walk-around and visually check the tires for inflation, look for any fluids on ground under the vehicle, and condition of light lenses and windshield; and
 - b. Once in the vehicle, activate the emergency brake if it is not already set.After starting the engine, the selective procedures that relate to vehicle maintenance are:
 - a. Check the engine oil gauge or light;
 - b. Check the engine temperature gauge or light;
 - c. Check the alternator gauge or light; and
 - d. Check the fuel gauge.
12. At each fuel stop, the following preventive maintenance check should be made:
 - a. Check the engine oil;
 - b. Check windshield washer fluid;
 - c. Visually check the tires; and
 - d. Clean the windshield and lights.
13. Preventive maintenance checks that should be done at least once per month are:
 - a. Check the fluid levels for transmission, steering, cooling, brakes, engine, and washer fluid;
 - b. Check the belts and hoses;
 - c. Check the wiper blades;
 - d. Check the air pressure in the tires; and
 - e. Check all of the lights.
14. The owner's manual will show the recommended maintenance intervals for the various components of the motor vehicle. Some of the maintenance services are:
 - a. Engine oil and filter change;
 - b. Lubrication schedule for selective areas;
 - c. Other fluid changes and filters if applicable;
 - d. Tire rotation;
 - e. Steering and suspension checks; and
 - f. Engine tune-ups.

15. There are various methods for finding a qualified garage and mechanic and some of these are:
 - a. Talk with people you know and respect;
 - b. Check with your local Better Business Bureau;
 - c. Check with your local motor club; and
 - d. Visit your local garages and dealers to check on the certificates of the technicians and mechanics.
16. Pennsylvania's annual vehicle safety inspection must be performed at an authorized inspection station every twelve months. The number on the sticker indicates the date when the vehicle must be inspected, and the vehicle can be inspected up to ninety days before the inspection expiration date. The safety inspection involves the following vehicle components:
 - a. Steering and suspension system (tires, wheels, shocks, tie rods);
 - b. Visibility systems (windshield, wipers, washers, headlamps, brake lights, turn signals, emergency flasher, back-up lights, parking lights); and
 - c. Exhaust system and sealed passenger compartment.
17. Specific locations in Pennsylvania require a vehicle emissions inspection and there are currently eleven counties identified where vehicles registered in their counties are required to be inspected annually. The emissions inspection program covers all gasoline powered, model year 1975 or newer cars, vans and light-duty trucks, weighing 9,000 pounds or less. The vehicle emissions inspection is required before completing the safety inspection.
18. To calculate the number miles per gallon of fuel, one can follow the following steps:
 - a. Fill the fuel tank and record the odometer reading or set the trip odometer to zero;
 - b. Drive the vehicle as needed until there is approximately a half tank of fuel;
 - c. Refill the fuel tank and record the number of gallons and the odometer or trip odometer reading; and
 - d. Subtract the first odometer reading from the second reading and divide this number of miles by the number of gallons of fuel used to refill the tank. The result or product is the number of miles per gallon (mpg).
19. There are ways to improve fuel efficiency when operating a motor vehicle and they are:
 - a. When starting a cold engine, drive it at moderate speed for the first few miles;
 - b. Avoid excessive engine idling;
 - c. When driving in the city, coast to a stop whenever possible and moderately accelerate to desired speed;
 - d. When driving at speeds greater than 45 mph, keep windows closed to reduce wind resistance;
 - e. Avoid hard acceleration and braking;
 - f. Maintain maximum air pressure in the tires; and
 - g. Maintain proper wheel alignment.

Resources

1. Textbooks
 - a. Drive Right
 - b. Responsible Driving
 - c. How to Drive
 - d. License to Drive
2. Other Resources
 - a. Owner's Manual
 - b. Pennsylvania Driver's Manual (current)
 - c. Pennsylvania Vehicle Code (current)
 - d. Consumer Reports Magazine from the Consumer's Union
3. Internet
 - a. www.hwysafety.com
 - b. www.edmunds.com
 - c. www.kellybluebook.com

Module V—Laboratory Instruction

Laboratory Instruction

Rationale

The laboratory phase of instruction provides the beginning driver with the opportunity to apply what has been or is being taught in the classroom. The laboratory should be considered an extension of the classroom. It provides the beginning driver the opportunity to apply, practice and be evaluated on the various parts of the driving task. Pennsylvania currently requires a minimum of six hours (360 minutes) of planned behind-the-wheel instruction from a certified/licensed instructor. This minimal time requirement necessitates the support of the parents/guardians and their taking an active role in this total teaching/learning process. Graduated Driver Licensing requires the new driver to complete a minimum of sixty-five hours of supervised practice on the learner's permit with ten of those hours during night-time and five hours in inclement weather. The hours provided by the school can be included as part of the sixty-five hours.

Definition of Terms

OFF-STREET LESSONS: This is the phase of behind-the-wheel instruction in which the student driver is learning basic manipulative control of the motor vehicle. The driver has a chance to learn and practice certain skills prior to going on-street. Ideal locations are parking lot areas or any other areas where there is no traffic.

ANTICIPATED PROBLEMS: This is when the instructor anticipates specific problems with certain parts of the driving task. The instructor will be more conscious of correct and incorrect responses and can quickly reinforce acceptable performance or correct negative performance.

LEARNING SETS: This is another name for instructional objectives, but planned delivery is a little different from the traditional instructional objective format. Planned learning sets are important because they:

- Always proceed from easier to more difficult
- Demonstrate proficiency before moving to next set.
- Determine direction that driver should proceed (e.g., demonstrate competent left turns before proceeding with right turns)

Knowing what the student should do beforehand enables the instructor to be better prepared to complement or correct the planned procedure.

BTW CODE: When teaching more than one student at a time during a behind-the-wheel lesson, the instructor should vary who drives first, second and third.

DRIVER EDUCATION LABORATORY RECORD: When teaching the laboratory phase of driver education, it is extremely important to maintain an accurate record on each student for liability

reasons. A student should not proceed to the next lesson until satisfactory performance or the planned objectives for the prior lesson have been achieved. (See Appendix A)

DRIVER LOG: This should be the primary line of communication between the instructor and the parents/guardians. Specific information pertaining to the beginning driver must be entered into the log and then read by both parties. (See Appendix B)

Methodology

Scheduling

1. Students should be scheduled for the laboratory phase of instruction when they apply for and pass their test for the learner's permit. A student must be a minimum of 16 years of age.
2. A student should be currently taking the classroom phase of instruction or should have completed the classroom phase.
3. The behind-the-wheel lessons should be scheduled over an extended period of time to allow for supervised practice of the beginning driver. With a practice to instruction ratio of two or three to one, the beginning driver should be able to satisfactorily accomplish all of the planned lesson objectives.
4. The recommended number of minutes at the end of each lesson plan should serve only as a guide. The instructor needs to spend the amount of time necessary for the student to demonstrate satisfactory performance of the planned objectives for each planned experience.

Instructional Phases

1. The behind-the-wheel phase of instruction is the actual time that the beginning driver is *behind-the-wheel and in control of the car*. Once again, the student must have a minimum of 360 minutes of this phase of instruction to complete the state approved program.
2. When the student is not behind-the-wheel of the car, he/she should be observing. There is no minimal amount of time required by the state for observation. However, this is an important part of the teaching/learning process and planned learning activities should be scheduled for the observers every time they have an in-car lesson. These are identified in the respective lesson plans.
3. Driving Simulation and Multiple-Car-Driving Ranges are other state approved laboratory methods of instruction. They can supplement the in-car phase and there are specific ratios identified in the administrative guide.
4. Off-street instruction is designed for the student to learn and practice basic manipulative control of the car in an area that has no traffic. Certain skills must be taught, practiced and demonstrated before going on-street.
5. On-street or on-road instruction is a selected traffic environment for the student driver to apply, practice and be evaluated regarding the planned objectives for each planned route or area.

Driving Environments

1. The instructor needs to become totally familiar with all of the highway environments that are available in his/her instructional area.
2. Using the laboratory lesson plans in this guide, the instructor should attempt to identify similar areas in his/her respective location, (e.g. residential, open highway, controlled access, rural/country roads, and urban areas). Realizing that certain geographical areas in the state will not allow instruction with similar situations in all of the identified environments, the instructor should attempt to simulate as many of these environments as possible.
3. The instructor should attempt to take traffic slides or video clips of the various environments for instructional use in the classroom. These visuals should serve as an excellent resource when teaching selective visual skills to the beginning driver in the classroom.
4. The instructor needs to carefully examine all of the available teaching/learning environments and categorize them by degree of difficulty. The beginning driver should be expected to demonstrate satisfactory performance of the planned objectives for a respective environment before moving on to the next level of difficulty. The parents/guardians need to be aware of this planned learning progression for maximum safety and efficiency.
5. It is important that the parents/guardians know the environments that are available in their geographical area. They are expected to provide the necessary supervised practice in that respective area or similar area, after their beginning driver has been introduced to that area by the instructor.

Parents/Guardians

1. Before the beginning driver starts the laboratory phase of instruction, the parents/guardians need to be involved immediately in this phase of instruction. They are a very important part of the overall teaching/learning process.
2. The instructor should schedule a meeting with the parents/guardians and the students to explain the respective roles and responsibilities of the instructor, the student, and the parents/guardians. This meeting should take no longer than 40 to 45 minutes. This meeting should be scheduled for a Wednesday or Thursday evening and a make-up day for the following Saturday morning. If the parent/guardian is not able to make either of these meetings, then an individual appointment will need to be scheduled.
3. Lines of communication need to be established so that all three parties are aware of the planned progression of learning for the new driver.
4. Information regarding the respective lesson plans, their objectives, descriptions of the environments, etc., should be discussed and given to the parents/guardians. The individual driving log should be discussed, and it should be shown how the instructor and the parents/guardians will make entries and use it. Any laboratory manual that will be used for instruction should also be discussed.

5. If the instructor is not able to schedule night driving lessons with the students, then the parents/guardians must provide this initial learning experience. Going from the simpler to the more complex environments need to be discussed and specific objectives should be identified.

Resources

1. Textbooks and their accompanying instructional materials that the instructor needs for this phase of instruction include but are not limited to:
 - a. *Drive Right*
Scott, Foresman and Company
 - b. *How to Drive*
American Automobile Association
 - c. *License to Drive*
Alliance for Safe Driving
 - d. *Responsible Driving*
American Automobile Association
2. Laboratory manuals and the accompanying instructional guides that the instructor needs for this phase of instruction include but are not limited to:
 - a. *Handbook for Learning to Drive*
Safety Enterprises
Bloomington, IL
 - b. *Teacher Guide for the Handbook Learning to Drive*
Safety Enterprises
Bloomington, IL
 - c. *Empower Yourself with Zone Control Driving*
Interactive Driving Systems, Inc.
Cheshire, CT 06410
 - d. *Pennsylvania's Parental Guide*
Department of Transportation
Harrisburg, PA
 - e. *Parent/Teen Handbook*
American Automobile Association

It should be noted that the Teacher Guide for the Handbook Learning to Drive has excellent masters for Check Sheets for the observers. This teacher guide accompanies the Handbook for Learning to Drive. These masters can be duplicated, or they can be changed to fit your needs. Reference is made to these and other observer check sheets in the lesson plans.

3. Forms and records that the instructor needs for this phase of instruction include but are not limited to:
 - a. Driver Education Laboratory Record (see Appendix A)
 - b. Student Driving Log (see Appendix B)
 - c. Other Samples of Checklists (See Appendix C)
 - d. Student Performance Sheets for Selective Environments (See Appendix D)

These resources and others will enable the instructor to provide a positive and effective learning environment when teaching the behind-the-wheel phase of instruction.

Lesson Number One: Off-Street Lesson

1. Overall Goal
 - a. The student will practice and demonstrate entry-level procedural tasks needed for selective on-street lessons.
2. Required Entry Level
 - a. The procedural tasks will have been introduced in the classroom setting and the students will also have a procedural sheet for reference purposes
 - b. No prior driving experience is needed for this lesson.
3. Required Resources
 - a. Driver education vehicle with instructor mirrors
 - b. Parking lot or similar area
 - c. Traffic cones
 - d. Clipboard(s)
 - e. Check sheets for backseat observers e.g., Pre-Ignition Procedures, Ignition Procedures, Preparing to Move and Moving, Preparing to Stop and Securing, Lane Change Procedures, Left and Right Turns, Turnabouts
4. Objectives
 - a. Vehicle familiarization
 - b. Pre-ignition
 - c. Ready to drive position
 - d. Ignition
 - e. Preparing to move
 - f. Moving forward
 - g. Moving backward
 - h. Stopping, securing, shutting down
 - i. Lane change
 - j. Left turn
 - k. Right turn
 - l. U-turn
 - m. Three-point turnabout
 - n. Two-point turnabout
5. Instructional Objectives
 - a. The driver will demonstrate and practice selective pre-ignition procedures
 - i. Walk around vehicle to check clearance and condition
 - ii. Enter vehicle and put key in ignition
 - iii. Secure and lock doors
 - iv. Adjust seat
 - v. Adjust head restraint
 - vi. Adjust steering wheel
 - vii. Adjust mirrors
 - viii. Stow and/or secure packages and objects
 - ix. Make sure all passengers have fastened their safety belts
 - x. Fasten safety belt

- xi. Gear selector in **park** and emergency brake is set
- b. The driver will demonstrate and practice selective ignition procedures
 - With heel of foot on floor:
 - i. Place foot on brake and press
 - ii. Turn key to **on** position and check all instruments and gauges
 - iii. Turn key to **start** position and release after engine starts
 - iv. Turn headlights on with low beams
 - v. Check all instruments and gauges to make sure everything is normal
- c. The driver will locate and/or use selective gauges and instruments in the motor vehicle
 - i. Turn signals
 - ii. Emergency flashers
 - iii. High and low beams
 - iv. Horn
 - v. Gear selector indicator
 - vi. Windshield wipers and washers
 - vii. Air conditioner, heater, defroster controls
 - viii. Brake indicator(s)
 - ix. Radio and controls
- d. The driver will demonstrate and practice the ready position to drive a motor vehicle
 - i. Sit straight and high with back pressed against back of seat
 - ii. Sit directly behind the steering wheel and no closer than ten inches
 - iii. Automatic transmission press left foot against **dummy pedal** or fire wall
 - iv. Hands on outside of steering wheel no higher than 9 and 3 o'clock and no lower than 7 and 5 o'clock
 - v. Heel of right foot on floor to move from accelerator to brake or vice versa
- e. The driver will demonstrate and practice preparing to move procedures
 - i. Foot on brake
 - ii. Gear selector to respective gear
 - iii. Release parking brake
 - iv. Check projected path-of-travel and check around vehicle
 - v. Signal when applicable
 - vi. Proceed
- f. The driver will demonstrate and practice stopping, securing and shutting down procedures.
 - i. Check projected path-of-travel
 - ii. Check traffic behind
 - iii. Release accelerator and squeeze brake
 - iv. Once stopped, apply Parking Brake
 - v. Shift to park
 - vi. Go from left to right or vice versa and turn off all accessories
 - vii. Close windows as needed
 - viii. Shut down engine and remove key

- ix. Unfasten safety belt
 - x. Check for traffic
 - xi. Exit vehicle
 - xii. Lock all doors
- g. The driver will demonstrate and practice moving forward in a straight line with the motor vehicle
- i. Project a safe path-of-travel
 - ii. Smoothly accelerate while maintaining lane position
 - iii. Smoothly stop at predetermined locations
- h. The driver will demonstrate and practice moving backward in a straight line with the motor vehicle
- i. Foot on brake, shift to reverse gear
 - ii. Brace left foot against dummy pedal or fire wall with automatic transmission
 - iii. Turn to the right with right arm over seat and left hand at 12 o'clock
 - iv. Search out rear window and aim high with search
 - v. Smoothly accelerate and stop
- i. The driver will demonstrate, and practice left and right lane changes with the motor vehicle from both a stopped position and moving position
- i. Check intended path-of-travel
 - ii. Check traffic to the rear and sides with mirrors
 - iii. Signal intention
 - iv. Recheck to the rear and respective blind spot
 - v. When clear, move into the new lane adjusting to the flow of traffic
 - vi. Cancel signal and check speed and position
- j. The driver will demonstrate, and practice left and right turns from both a stopped and moving position in the motor vehicle
- i. Check intended path of travel
 - ii. Check traffic behind
 - iii. Signal intentions early and correctly
 - iv. Position vehicle in proper lane and lane position
 - v. Search through turning path
 - vi. On left turns, begin steering slightly before the front of the vehicle gets to the lane you wish to enter
 - vii. On right turns, allow your front wheels to follow the turning radius of the curb or the lane you wish to enter
 - viii. Practice both push-pull-feed method and hand-over-hand method of steering for left and right turns
 - ix. Search through turn and aim high
 - x. Selectively check traffic behind once turn is completed
- k. The driver will demonstrate and practice a U-turn in the motor vehicle
- i. Make certain it is permitted
 - ii. Safe position, e.g., good sight distance to the front and rear, plenty of clearance, little to no traffic

- iii. Stop vehicle as far right as possible, e.g., curb, shoulder of highway
 - iv. Search traffic in both directions
 - v. Signal intentions and check traffic again before starting
 - vi. Slow vehicle and hard steer
 - vii. Straighten vehicle and resume speed
- I. The driver will demonstrate and practice a three-point turnaround in the motor vehicle
- i. Select a safe position, e.g., good sight distance to the front and rear, plenty of clearance, little to no traffic
 - ii. Stop vehicle as far right as possible, e.g., curb or shoulder of highway
 - iii. Check traffic in both directions
 - iv. Signal intentions and check traffic again before starting
 - v. Slow vehicle and hard steer
 - vi. When front wheels are approximately four feet from curb begin steering hard right while continuing to move forward slowly
 - vii. Stop when near edge of curb or road and check traffic in both directions
 - viii. Shift to reverse, look over right shoulder and slowly back until approximately four feet from curb or edge of road
 - ix. Bring eyes forward and if there is space enough to clear, put vehicle in drive and proceed forward. If more space is needed, continue backing while looking over left shoulder toward curb or edge of road and stop when approximately one foot from curb or edge of road.
- m. The driver will demonstrate and practice the **two-point turnabout** with the motor vehicle on the right side of the street and the left side of the street
- **Right Side**
 1. Signal intention to stop, scan driveway as you go past it
 2. Position vehicle approximately three feet from the curb and back of vehicle three to five feet past the turning radius of the driveway
 3. Prepare to back to the right
 4. Slow car and hard steer to the right
 5. Stop when there is sufficient space to pull out and proceed in the other direction
 - **Left Side**
 1. Signal intention to slow and turn into a driveway on the left
 2. Enter the driveway and stay to the right side
 3. When back end is three to five feet past the turning radius of the driveway and street, stop
 4. Prepare to back to the right
 5. Slowly back and hard steer right
 6. Stop when there is sufficient space to pull forward and proceed in other direction

6. Learning Activities
 - a. Observers in the back seat should be evaluating the driver's procedural skills with planned check sheets that are identified in required resources
 - b. Students should have procedural sheets to review and practice with parents/guardians
7. Evaluation
 - a. The instructor will evaluate the procedural skills of the driver, complimenting correct response and correcting incorrect response
 - b. The driver must demonstrate satisfactory performance of all these objectives before moving to the first on-street lesson
8. Length of Time
 - a. Forty-five minutes of instruction per driver or until satisfactory performance of the planned objectives.

Lesson Number Two: On-Street Lesson: Residential Area

1. Overall Goal
 - a. The student will practice and apply the previously learned objectives from lesson one in an on-street area with minimal traffic, low speeds and many intersections. This type of environment is a residential area that will usually possess all of the characteristics.
2. Required Entry Level
 - a. Successful demonstration of the procedural tasks from lesson one
 - b. Previously learned objectives from the classroom instruction regarding rules and responsibilities at intersections, visual search procedures, visual identification of traffic controls
3. Required Resources
 - a. Driver education vehicle with appropriate instructor mirrors
 - b. Residential area
 - c. Clip boards
 - d. Check sheets for backseat observers e.g., Checklist for Basic Maneuvers, Observation Check Sheet for Eye Habits
4. Objectives
 - a. Entering and leaving flow of traffic (pulling away from curb and pulling into the curb)
 - b. Negotiating intersections
 - c. Identifying traffic controls (primarily signs and markings)
 - d. Using selective searching techniques
 - e. Negotiating turnabouts
 - f. Interacting with other users
5. Characteristics of the Practice Environment
 - a. Minimal traffic
 - b. Low speeds (preferred 25 mph maximum)
 - c. Traffic controls that are primarily signs and markings, e.g., crosswalks and stop lines
 - d. Two-way and one-way streets if available
 - e. Open and blind intersections
6. Learning Sets
 - a. Lane change maneuvers (entering and leaving traffic flow)
 - b. Negotiating intersections with pedestrian crosswalks
 - i. Straight
 1. Stopping/moving
 2. Single stop/double stop (blind intersection)
 3. Two-way and one-way streets
 - ii. Left turn/right turn (left turns are easier than right turns and should be demonstrated before doing right turns)
 1. Stopping/moving
 2. Single stop/double stop (blind intersection)

3. Two-way and one-way streets
 - c. Identifying and responding to one-way and two-way streets
 - d. Negotiating a two-point turnabout on left and right side
 - e. Negotiating a three-point turnabout
7. Anticipated Problems
 - a. Failing to check blind spots on lane changes
 - b. Failing to check mirror(s) at least once per block
 - c. Improper lane position for intersection maneuver from both two-way and one-way streets
 - d. Failing to stop for pedestrian crosswalk
 - e. Not coming to a complete stop when required
 - f. Waiting to make left turn with wheels turned
 - g. Failing to use the "second glance" technique before taking initiative at intersections
 - h. Failing to sight through turns
 - i. Not following the radius of curb on right turns
 - j. Speed too fast on turns
 - k. Dry steering on turnabouts, e.g., turning steering wheel while car is stationary
8. Learning Activities
 - a. Introduction of lesson (objectives and type of driving environment)
 - b. Summarizing lesson (strengths and weaknesses of driver)
 - c. Observers in backseat should be using check sheets related to objectives of the lesson. These are available in previously identified resources.
 - d. Once the students have been introduced to the residential area, by the instructor, the parents/guardians should have the new drivers practice the established objectives in the same or similar environment.
9. Evaluation
 - a. The student must demonstrate satisfactory performance of the lesson objectives before progressing to the next lesson.
10. Length of Time
 - a. Thirty-five minutes of instruction per driver or until satisfactory performance of the planned objectives.

Lesson Number Three: Off-Street Lesson

1. Overall Goal
 - a. The student will practice and demonstrate selective parking techniques before proceeding to the next on-street lesson.
2. Required Entry Level
 - a. Successful demonstration of the objectives from Lesson Two
 - b. Angle and perpendicular parking will have been introduced in the classroom setting and students will have procedural sheets for these two skills.
3. Required Resources
 - a. Driver education vehicle with appropriate instructor mirrors
 - b. Parking lot
 - c. Traffic cones
 - d. Clip boards
 - e. Check sheets for backseat observers e.g., Angle Parking, Perpendicular Parking
4. Objectives
 - a. Entering and exiting an angle parking space
 - b. Entering and exiting a perpendicular parking space
5. Instructional Objectives
 - a. The driver will demonstrate and practice entering an angle parking space
 - i. Check traffic in all directions
 - ii. Check for other user clues that a vehicle might be exiting a parking space
 - iii. Signal intentions early and stay out as far as possible from parked vehicles
 - iv. Stop when you can see down the near painted line of the space that you are entering
 - v. Slow speed with hard steer
 - vi. Check your front fender opposite your steering input and the side of your vehicle on the side of your steering input
 - vii. Center your vehicle as you creep forward with wheel straight
 - viii. Pull to within one foot of any object in front and stop
 - b. The driver will demonstrate and practice exiting an angle parking space
 - i. Search carefully around the vehicle and prepare to back
 - ii. Slowly back straight and stop when you can see past vehicle on either side of you
 - iii. Continue backing with a hard steer in direction dictated
 - iv. Check the side of vehicle on side of steering and front fender opposite of the steering
 - v. Stop when there is sufficient space to pull forward in new path-of-travel
 - c. The driver will demonstrate and practice entering a perpendicular parking space
 - i. Check traffic in all directions
 - ii. Check for other user clues that a vehicle might be exiting a parking space
 - iii. Signal intentions early and try to move out as far as possible from the parking space (minimum of 8-9 feet)

- iv. Stop when your vehicle's front end breaks the extended near line of the space you are entering
 - v. Proceed with a slow car and hard steer
 - vi. Check front fender opposite the steering input and the side of your vehicle on the side of the steering input
 - vii. Center vehicle as you creep forward
 - viii. Pull to within one foot of any object in front and stop
 - d. The driver will demonstrate and practice exiting a perpendicular parking space
 - i. Check carefully around the vehicle and prepare to back
 - ii. Slowly back straight and stop when you are in line with the bumper of the vehicle on either side of you
 - iii. Continue backing with steering in direction you wish to back
 - iv. Check the front fender opposite the steering and the side of your vehicle on the side of the steering
 - v. Stop when there is sufficient space to pull forward in a new path-of-travel
- 6. Learning Activities
 - a. Observers in the backseat will be observing and evaluating the driver's procedural skills with a check sheet
 - b. Students should have procedural sheets to review and practice with parents/guardians and continue to practice in the residential environment
- 7. Evaluation
 - a. The instructor should observe and evaluate student's performance by complimenting correct responses and correcting errors
 - b. Satisfactory performance of the lesson's objectives are necessary before proceeding to the next on-street lesson
- 8. Length of Time
 - a. Fifteen minutes of instruction per driver or until satisfactory performance of the planned objectives.

Lesson Number Four: On-Street Lesson: Open Highway

1. Overall Goal
 - a. The student will demonstrate vehicle control at higher speeds by increasing his/her sight distance and plan ahead. This type of environment is the open highway area with various posted speeds and minimal to moderate traffic.
2. Required Entry Level
 - a. Satisfactory performance of controlling the vehicle at lower speeds (residential area)
 - b. Satisfactory performance of angle and perpendicular parking
 - c. Previously learned objectives from classroom instruction that taught visual skills relating to sight distance, projected path-of-travel, identification of traffic controls and identification of highway conditions
3. Required Resources
 - a. Driver education vehicle with appropriate instructor mirrors
 - b. Driving environment that has posted speeds of 25, 35, and 45 miles per hour, minimal traffic and shopping centers or malls
 - c. Clip boards
 - d. Check sheets for backseat observers, e.g., Backseat Bingo Game, Identifying Highway Conditions, Basic Procedures, Mirror Usage
4. Objectives
 - a. Vehicle control at higher speeds
 - b. Increased sighting distance
 - c. Orderly search pattern
 - d. Identifying traffic controls
 - e. Identifying highway conditions
 - f. Planning ahead
 - g. Lane selection and position within the lane
 - h. Negotiating multiple-lane intersections
 - i. Selecting a safe gap for crossing or entering traffic
 - j. Communicating
 - k. Moving lane changes
 - l. Negotiating and parking in shopping centers and malls
5. Characteristics of the Practice Environment
 - a. Variable speeds (25 to 45 plus)
 - b. Minimal to moderate traffic
 - c. Variable sight distances
 - d. Various traffic controls (signs, signals, markings)
 - e. Multiple lanes
 - f. Multiple-lane intersections
 - g. Shopping centers/malls

6. Learning Sets
 - a. Vehicle control at greater speeds
 - b. Planning ahead (control the speed of the vehicle primarily with the accelerator)
 - c. Lane selection and changing
 - d. Communication
 - e. Gap selection
 - f. Selective searching
 - g. Angle and perpendicular parking
7. Anticipated Problems
 - a. Limited sight distance which will cause erratic steering
 - b. Limited sight distance causing erratic speed changes
 - c. Not driving within five miles of the posted speed limits when conditions permit
 - d. Difficulty in maintaining a selected lane position
 - e. Failing to identify and select proper lane for travel or maneuver
 - f. Failing to check blind spot when needed
 - g. Speed control and search at intersections
 - h. Selecting correct lanes or aisles in shopping centers/malls
 - i. Difficulty in anticipating changing traffic signals
8. Learning Activities
 - a. Introduction of lesson (objectives and type of driving environment)
 - b. Primary objective is to expand the sight distance to better plan ahead. Try to make speed adjustments primarily with accelerator.
 - c. Summarize lesson (strengths and weaknesses demonstrated)
 - d. Observation activity in the back seat
 - e. Once the students have been introduced to the open highway environment, by the instructor, the parents/guardians should have the new drivers practice the established objectives in the respective environment. The new drivers should now be practicing in two environments with minimal traffic (residential, open highway)
9. Evaluation
 - a. The student must demonstrate satisfactory performance of the lesson objectives before progressing to the next lesson.
10. Length of Time
 - a. Thirty minutes of instruction per driver or until satisfactory performance of the planned objectives.

Lesson Number Five: On-Street Lesson: Moderate Traffic Urban Area

1. Overall Goal
 - a. The student has demonstrated vehicle control at variable speeds with minimal traffic, he/she is now ready to drive in an environment that has more traffic users but lower speeds. The driver is now challenged to use a disciplined visual search for traffic controls, highway conditions and other user clues. Their only benefit in this environment is the lower speeds because of the time needed to identify and process information. This type of environment is usually duplicated with an urban area, but only with moderate traffic.
2. Required Entry Level
 - a. Satisfactory performance of the objectives associated with Lesson Four
 - b. Previously learned objectives from classroom instruction that taught visual skills relating to identifying other user clues and managing space with time
3. Required Resources
 - a. Driver education vehicle with appropriate instructor mirrors
 - b. Urban driving environment with two-way and one-way streets, multiple traffic controls, moderate number of other use, public parking lots/garages, multiple lane intersections. If there is an extremely busy business area, try to avoid this and save for a later lesson. You want to challenge the driver, but don't overload him/her.
 - c. Clip boards
 - d. Check sheets for backseat observers, e.g., Backseat Bingo Game, Identifying Highway Conditions, Identifying high or low probability of closures from other users
4. Objectives
 - a. Search, Identification and Prediction
 - b. Maintaining adequate space margins
 - c. Interacting with a larger number of highway users
 - d. Negotiating a variety of intersections
 - e. Using a parking garage/lot
5. Characteristics
 - a. Increased number of highway users
 - b. Limited space and visibility
 - c. Greater number of traffic controls
 - d. Multiple lane intersections and complex intersections
 - e. Maximum posted speed is 35 mph
 - f. Parking garage/lot
6. Learning Sets
 - a. Negotiating a variety of intersections with a variety of lanes and controls
 - b. Interacting with a greater number of highway users
 - c. Identifying and responding to real and/or potential hazards
 - d. Adjusting speed and/or position and communicating when applicable
 - e. Safe and efficient use of parking garage/lots

7. Anticipated Problems

- a. Not identifying areas of less space or visibility that require a speed and/or position adjustment
- b. Incorrect signaling at complex intersections
- c. Inadequate searching (sight distance)
- d. Failing to observe pedestrian right-of-way
- e. Not looking through left turn prior to selecting a safe gap for a left turn
- f. Failing to search through right turn prior to initiating a right turn
- g. Failing to scan to the left when making a right turn
- h. Not pulling into intersection when waiting to make a left turn at an unprotected left turn traffic signal
- i. Failing to anticipate changing traffic signals

8. Learning Activities

- a. Introduction of lesson (objectives and type of driving environment)
- b. Primary objective is to challenge the driver with more controls and other users thus forcing him/her to selectively identify and evaluate real and/or potential hazards
- c. Summarize lesson (strengths and weaknesses)
- d. Observation activity in back seat
- e. Once the students have been introduced to the moderate traffic in-town environment by the instructor, the parents/guardians should have the new drivers practice the established objectives in the respective environment. The new drivers should now be practicing in three environments (residential, open highway, moderate traffic in-town)

9. Evaluation

- a. The student must demonstrate satisfactory performance of this lesson before proceeding to the next on-street lesson.

10. Length of Time

- a. Thirty minutes of instruction per driver or until satisfactory performance of the planned objectives.

Lesson Number Six: On-Street Lesson: Expressway/Freeway

1. Overall Goal
 - a. After the student has demonstrated satisfactory performance in the in-town/moderate traffic environment, he/she is now ready to demonstrate satisfactory performance in the expressway or controlled access highway environments.
2. Required Entry Level
 - a. Satisfactory performance of the objectives in lesson five (moderate traffic/in-town)
 - b. Previously learned classroom objectives dealing with controlled access highway driving and the concept of measuring distance with time
3. Required Resources
 - a. Driver education vehicle with appropriate instructor mirrors
 - b. Expressway driving environment that affords a variety of interchanges
 - c. Clipboards/Stopwatch
 - d. Check sheet for back seat activity that involves measuring following distance, stopping distance and seeing distance, e.g., Timed Distances
4. Objectives
 - a. Maintaining a constant speed when conditions permit
 - b. Entering and exiting expressways
 - c. Cooperating with other drivers who are entering or exiting
 - d. Demonstrate satisfactory search to reduce the risk of real/potential hazards
 - e. Demonstrate satisfactory communication
 - f. Measuring distances with time
 - g. Passing
 - h. Safe and efficient use of the vehicle's cruise control system
5. Characteristics
 - a. Controlled access highways
 - b. Posted speeds of 55 plus mph
 - c. Variety of interchanges
 - d. Multiple lanes
6. Learning Sets
 - a. Entering and exiting controlled access highway
 - b. Speed control
 - c. Searching potential conflict areas, e.g., interchanges, disabled vehicles, emergency cross-over areas
 - d. Cooperating with other drivers
 - e. Passing slower moving vehicles
 - f. Measuring distances with time
 - g. Using cruise control in the motor vehicle, e.g., set, cancel, reset, accelerate, decelerate

7. Anticipated Problems
 - a. Speed control on ramps
 - b. Not matching speed with selected gap on expressway
 - c. Not making gap selection before the acceleration lane of the ramp
 - d. Not using mirrors to check traffic behind and on expressway
 - e. Not maintaining space cushion in front when entering
 - f. Not using full acceleration and merge lane when entering
 - g. Not taking the initiative when applicable at a weave lane
 - h. Slowing on the expressway prior to exiting when not applicable
 - i. Maintaining constant speed control on expressway
 - j. Not searching an interchange on the approach and pass
 - k. Projecting distance with time, e.g., identifying four to six seconds from a reference point, identifying number of seconds in relation to sight distance, identifying seconds in following
 - l. Selectively searching mirrors and blind spots
 - m. Slowing after initiating a pass of a slower moving vehicle
 - n. Failure to signal when appropriate or cancel signal once activated
8. Learning Activities
 - a. Introduction of lesson (objectives and type of driving environment)
 - b. Summarize the lesson (strengths and weaknesses)
 - c. Back seat activity with stop watch and check sheet
 - d. Once the students have been introduced to the expressway environment by the instructor, the parents/guardians should have the new drivers practice the established objectives in the respective environment. The new drivers should now be practicing in four environments (residential, open highway, moderate traffic in- town, expressway)
9. Evaluation
 - a. The student must demonstrate satisfactory performance of this lesson before proceeding to the next on-street lesson.
10. Length of time
 - a. Thirty minutes of instruction per driver or until satisfactory performance of the planned objectives.

Lesson Number Seven: Off-Street Lesson

1. Overall Goal
 - a. The student will practice and demonstrate parallel parking and responding to selected vehicle emergencies
2. Required Entry Level
 - a. Satisfactory performance of the objectives in lesson six
 - b. Previously learned classroom objectives dealing with parallel parking, parking on an uphill and downhill grade, and responding to vehicle emergencies.
3. Required Resources
 - a. Driver education vehicle
 - b. Parking lot area
 - c. Traffic cones
 - d. Clipboards
 - e. Check sheets for selected procedures, e.g., Parallel Parking, Vehicle Emergencies
 - f. Procedural sheets for respected exercises
4. Objectives
 - a. Entering and exiting a parallel parking space
 - b. Parking on an uphill and downhill grade
 - c. Responding to the following emergencies caused by vehicle failure:
 - i. Engine stall
 - ii. Brake failure
 - d. Responding to the following emergencies caused by driver error:
 - i. Off-road wheel recovery
 - ii. Controlled braking with evasive steering
5. Instructional Objectives
 - a. The driver will demonstrate and practice entering a parallel parking space
 - i. Search traffic in all directions
 - ii. Signal your intentions with turn signal and communicate with brake lights
 - iii. Proceed to Check Point One which is:
 1. parallel to the vehicle in front of the space, two to three feet away
 2. rear bumpers aligned
 - iv. Prepare to back to the right and proceed with a slow vehicle and hard steer right
 - v. Stop at Check Point Two which is:
 1. sitting opposite of the rear bumper of the front vehicle
 2. look in your left side mirror and align the left side of your vehicle with the right front corner of the vehicle behind you (it is important to get this alignment before proceeding to the next check point).
 - vi. Slowly back while straightening the front wheels and maintaining the alignment identified above and stop at Check Point Three which is:
 1. Your front bumper is opposite the rear bumper of the vehicle in front

2. Your front wheels are straight
 - vii. You are now in a position to do a hard steer left while slowly backing your vehicle
 - viii. Once your vehicle is parallel to the curb continue to back while straightening the front wheels and stop when you are approximately one foot from the vehicle behind you
 - ix. Pull forward and center your vehicle between the two vehicles
- b. The driver will demonstrate and practice leaving a parallel **parking** space
 - i. Back straight and stop when you are approximately one foot from the vehicle behind
 - ii. Check traffic in all directions and activate your turn signal
 - iii. Proceed with the lane change procedure and do a slow vehicle and hard steer in the desired direction
 - iv. When you are sitting opposite of the rear bumper of the vehicle in front, begin steering in the opposite direction to maintain your new lane position. Check the side of your vehicle closest to the vehicle that is in front of the space
- c. The driver will demonstrate and practice parking on hills
 - i. Parking on a downgrade with curb, front wheels turned into curb
 - ii. Parking on an upgrade with curb, front wheels are turned away from curb
 - iii. Parking on a grade without a curb, front wheels are set so that the vehicle will run off or away from road if it rolls
- d. The driver will demonstrate and practice the response to the engine suddenly stalling
 - i. Quickly bump the transmission into neutral and attempt to restart the engine
 - ii. Once the engine starts, bump transmission back into drive gear
 - iii. If the vehicle was moving when engine stalled, continue to steer and clear the roadway by allowing the vehicle to drift while attempting to restart
 - iv. If standard transmission, press in clutch
- e. The driver will demonstrate and practice the response to brake failure
 - i. Immediately pump the brakes and shift to lower gear
 - ii. If this does not help, hold the parking brake release and slowly apply the parking brake. The hand opposite of holding the brake release should be at 12 o'clock on the steering wheel
- f. The driver will demonstrate and practice the response to off-road recovery
 - i. Firm grip on steering wheel and resist urge to steer immediately back onto roadway
 - ii. Ease off the accelerator and gently squeeze the brake
 - iii. Selectively bring the vehicle back "onto roadway at a slower speed and with less than a quarter turn of the steering wheel
- g. The driver will demonstrate and practice evasive steering action with controlled braking

- i. Driver should apply firm steady pressure on the brake without locking the wheels
 - ii. While braking, the driver will initiate steering to the right or left and immediately into the new path-of-travel
 - iii. Drivers will never steer more than 180° in either direction and in almost all instances less in completing this quick lane change
 - iv. Once in the new lane, safely stop the vehicle
6. Learning Activities
 - a. Observers in rear seat will observe and evaluate the driver's procedural skills with a check sheet
 - b. Students will have a procedural sheet for parking to review and practice with parents/guardians and the parents should continue to practice in the four previously learned environments (residential, open highway, moderate in-town, and expressway)
7. Evaluation
 - a. The instructor will evaluate student's performance by complimenting correct responses and correcting errors.
8. Length of Time
 - a. Thirty minutes of instruction per driver or until satisfactory performance of the planned objectives.

Lesson Number Eight: On-Street Lesson: Rural Roads

1. Overall Goal
 - a. The student will demonstrate both speed control and position selection while driving narrow, unmarked country roads. The student will also respond to selected vehicle and driver failures.
2. Required Entry Level
 - a. Satisfactory performance of the lesson objectives, in lesson seven.
 - b. Previously learned objectives from the classroom instruction that taught driving in the rural setting and responding to sudden emergencies.
3. Required Resources
 - a. Driver education vehicle with appropriate instructor mirrors
 - b. Rural country environment
 - c. Clipboards
 - d. Check sheet for back seat activity, e.g., Identification of Reduced Areas, Choosing Best Pathway.
4. Objectives
 - a. Identifying and responding to negative roadway conditions (space, visibility, traction)
 - b. Identifying clues for side roads, driveways and other problem areas
 - c. Responding to vehicle failure and driver error
 - i. Engine stall
 - ii. Brake failure
 - iii. Off-road recovery
5. Characteristics
 - a. Rural roads that are crowned, unmarked, narrow, little to no shoulders, and various compositions.
 - b. Limited visibility (sight and view to sides)
 - c. Limited space
 - d. Minimal traffic
 - e. Minimal traffic controls
6. Learning Sets
 - a. Identifying and responding to limited highway conditions
 - b. Identifying locations of hidden side roads, lanes and driveways
 - c. Responding to right wheel drop-off onto shoulder
 - d. Restarting stalled engine
 - e. Stopping a vehicle with the emergency brake
7. Anticipated Problems
 - a. Not identifying areas of limited space, visibility or traction
 - b. Not identifying clues for hidden side roads and driveways
 - c. Not slowing when responding to right wheel drop-off
 - d. Not letting car clear the intersection when attempting to restart stalled engine
 - e. Not holding button in or release out when using emergency brake to slow car

8. Learning Activities

- a. Introduction of lesson (objectives and type of driving environment)
- b. Summary of lesson (strengths and weaknesses)
- c. Back seat activity with check sheets
- d. Once the students have been introduced to the rural environment, by the instructor, the parents/guardians should have the new drivers practice the established objectives in the respective environment. The new drivers should now be practicing in five environments (residential, open highway, moderate traffic in-town, expressway, rural)

9. Evaluation

- a. The student must demonstrate satisfactory performance of this lesson before proceeding to the next on-street lesson.

10. Length of Time

- a. Thirty minutes of instruction per driver or until satisfactory performance of the planned objectives.

Lesson Number Nine: On-Street Lesson: Business District/Urban Setting

1. Overall Goal
 - a. The student will demonstrate the ability to reduce the risk of real and/or potential hazards in an environment that has a large volume of traffic in an urban setting.
2. Required Entry Level
 - a. This should be the most demanding environment for the new driver. Satisfactory completion of all other on-street lesson objectives is critical for the success of this lesson.
3. Required Resources
 - a. Driver education vehicle with appropriate instructor mirrors
 - b. Urban driving environment with two-way and one-way streets, multiple traffic controls, multiple lanes of traffic, complex intersections, and maximum amount of traffic
 - c. Clipboards and stop watch
 - d. Check sheets for back seat activity, e.g., Conflict Probabilities, Timing Situations, and Choosing Best Pathway.
4. Objectives
 - a. Maintaining adequate space margins
 - b. Timing driving actions
 - c. Selecting paths of travel
 - d. Communicating
 - e. Selective searching in relation to selected maneuvers
 - f. Negotiating complex intersections
 - g. Interacting with pedestrians
5. Characteristics
 - a. Large volume of traffic (motor vehicles, bicyclists, pedestrians)
 - b. Multiple lanes for selective use
 - c. Protected and unprotected turns
 - d. Complex intersections
 - e. Restricted space
 - f. Crosswalks in middle of blocks
6. Learning Sets
 - a. Making left and right turns from multiple lanes onto multiple-lane streets
 - b. Making lane changes
 - c. Interacting with a large volume of other users
 - d. Entering and exiting alleyways
 - e. Negotiating a left turn at an off-set intersection
 - f. Limit the number of city blocks when driving straight to two and then turn off and come back onto at another location
 - g. Parallel parking

7. Anticipated Problems
 - a. Not scanning through turn while waiting for safe gap
 - b. Not entering correct lane from turn
 - c. Not yielding to pedestrians in crosswalk
 - d. Not turning onto multiple lane street while oncoming vehicle is turning in same direction
 - e. Shortened sight distances
 - f. Not selectively using mirrors
 - g. Not checking selected blind spots
 - h. Not placing the vehicle in proper position for left turn at an off-set intersection
 - i. Failing to predict changing traffic signals
8. Learning Activities
 - a. Introduction of lesson (objectives and type of driving environment)
 - b. Summary of lesson (strengths and weaknesses)
 - c. Back seat activity with check sheets
 - d. Once the students have been introduced to the business environment by the instructor, the parents/guardians should have the new drivers practice the established objectives in the respective environment. The new drivers should now be practicing in all of the driving environments available in their respective areas.
9. Evaluation
 - a. The student must demonstrate satisfactory performance of this lesson before proceeding to the next on-street lesson
10. Length of Time
 - a. Thirty minutes of instruction per driver or until satisfactory performance of the planned objectives.

Lesson Number Ten: On-Street Lesson: Night Driving

1. Overall Goal
 - a. Scheduling permitting, the student will demonstrate his/her ability to reduce the risk of driving at night.
2. Required Entry Level
 - a. Satisfactory performance of the objectives associated with lesson nine.
 - b. Previously learned objectives from classroom instruction that taught how to reduce the risk of night driving.
3. Required Resources
 - a. Driver education vehicle
 - b. Selected parts of routes used with all of the other lessons.
4. Objectives
 - a. Preparing to drive at night
 - b. Using selected visual skills to increase identification
 - c. Using selected visual skills to improve vehicle control
 - d. Using selected visual skills to reduce glare
 - e. Speed control and tracking
5. Characteristics
 - a. Sections of the same routes that you used during daylight hours
 - b. With reduced visibility, you should work from simple to complex environments
 - i. Slow speed environment with maximum street lights, e.g., urban area
 - ii. Slow speed environment with minimal streets lights, e.g., residential area
 - iii. High speed on well-marked and signed multi-lane highways, e.g., controlled access
 - iv. High speed on well-marked and signed two-lane highways, e.g., open highway area
 - v. High speed on poorly marked and signed two lane highways, e.g., rural area
6. Learning Sets
 - a. Preparing to drive at night
 - b. Searching technique to address the risk of low visibility
 - c. Searching technique to help in maintaining lane position
 - d. Searching technique to avoid glare
 - e. Increasing visibility of pedestrians
7. Anticipated Problems
 - a. Allowing eyes to only stay in the path of the headlights and not beyond
 - b. Not using visual search to help maintain lane position
 - c. Looking at oncoming headlights
 - d. Not using the low/high beams selectively
 - e. Speed adjustment for high risk areas
8. Learning Activities
 - a. Introduction of lesson (objectives and type of driving environment)
 - b. Summary of lesson (strengths and weaknesses)

- c. Once the students have been introduced to night driving by the instructor, the parents/guardians should have the new drivers practice the established objectives in the various environments. If the instructor is not able to schedule the students for night driving, then the parents/guardians will provide this learning experience with guidance and direction from the instructor. The Pennsylvania Parental Guide recommends a minimum of four hours of practice driving at night.

9. Evaluation

- a. There are a great many risks that drivers must address with driving at night. If the instructor is able to provide this lesson, then the driver should be made aware of the risks and how to address them. This will enable the driver to continue to practice in this environment with the parents/guardians.

10. Length of Time

- a. If the student has an opportunity to drive a minimum of twenty-five minutes in one planned lesson with the instructor it will be beneficial. A second planned lesson with the instructor of an additional twenty minutes would be even more beneficial. Forty-five minutes of instruction per driver or until satisfactory performance of the planned objectives.

Lesson Number Eleven: On-Street Lesson: Driver Evaluation

1. Overall Goal
 - a. The student will demonstrate the ability to reduce the risks of real and/or potential hazards over a programmed evaluation route.
2. Required Entry Level
 - a. This is the last planned on-street lesson for the student, and it is the final on-road evaluation.
3. Required Resources
 - a. Driver education vehicle with appropriate mirrors
 - b. Planned on-road test route that should take approximately forty minutes
4. Objectives
 - a. Evaluate the driver's visual search in specified areas that neither increases or maintains the risk of a real or potential hazard
 - b. Evaluate the driver's selected speed in specified areas that neither increases or maintains the risk of a real or potential hazard
 - c. Evaluate the driver's position or direction control in specified areas that neither increases or maintains the risk of a real or potential hazard
 - d. Evaluate the driver's ability to communicate his/her intentions in selected areas that neither increases or maintains the risk of a real or potential hazard
5. Characteristics
 - a. The on-road evaluation should include segments of previous lessons, e.g., residential, open highway, expressway, rural, and business
 - b. The evaluation route should take approximately forty minutes
6. Evaluation Sets

The types of maneuvers or responses that should be built into the on-road evaluation are:

 - a. Selecting a path-of-travel
 - i. One-way and two-way roads
 1. limited space
 2. limited visibility
 3. merging traffic
 - ii. Negotiating intersections
 1. going straight
 2. turning left
 3. turning right
 - iii. Identifying traffic controls
 - iv. Maintaining a space margin
 - b. Selecting a speed
 - i. One-way and two-way roads
 1. limited space
 2. limited visibility
 3. merging with traffic

- ii. Negotiating intersections
 - 1. Approaching
 - 2. adjusting for traffic controls
 - 3. limited view to sides
 - iii. Maintaining a space margin
 - c. Selecting a gap
 - i. Negotiating an intersection
 - 1. turning left against traffic
 - 2. turning right or left when merging
 - 3. Merging or crossing
 - ii. Exiting
 - d. Communicating with other users
 - i. turning, stopping, passing
 - ii. making eye contact
 - iii. showing your presence
 - e. Searching
 - i. when approaching and negotiating an intersection
 - ii. when approaching a conflict area
 - iii. when approaching areas of less space and less visibility

The evaluation route should have as many complex situations as possible. These types of situations are usually found in the business district, residential areas, and high speed highways with uncontrolled and controlled access. You need to be totally familiar with your surrounding highway environments and identify those areas that place the greatest demand on the driver.

7. Evaluation

- a. When evaluating the performance of new drivers, it is either "yes", they did it or "no" they didn't do it. If you are not sure, then that segment is not scored. To arrive at a pass/fail percentage, you should evaluate a representative sample of new drivers, examine the scores, and then determine the cut-off.

8. Length of Time

- a. Forty minutes per driver allowed for evaluation.

Appendix A

Laboratory Record

Laboratory Record

Name: Expiration:
 Address: Restrictions:
 Phone #: Guardian:
 Instructor: Day Phone #:
 Permit #:

BTW Code

- #1 Drove Out
- #2 Middle
- #3 Drove In

Instructional Mode Code

- B: Behind-the-Wheel
- O: Observation

Date	Mode & Time	Lesson Objectives	Comments

Appendix B

Practice Driving Log

Practice Driving Log

Student:

Parent/Guardian:

Instructor:

Practice Driving Experience	Date	Time of Day	Total Driving Time	Practice Environments	Comments	Parent/Guardian and Instructor Sign Off
1.						
2.						
3.						
4.						
5.						
6.						
7.						
8.						
9.						
10.						
11.						
12.						
13.						
14.						
15.						
16.						
17.						
18.						
19.						
20.						
21.						
22.						
23.						
24.						
25.						
26.						
27.						
28.						
29.						
30.						

Appendix C

Sample of Checklists for Observers

Checklist for Basic Maneuvers

Driver:

Observer:

Date:

Instructions: The observer uses this checklist to help the driver remember the procedures. The observer places a check on the space when the driver is correct. Place a (0) on the space if the driver forgets the action. Each vertical line of boxes represents one trial.

Left Turns:

Procedure	Correct/ Incorrect	Correct/ Incorrect	Correct/ Incorrect	Correct/ Incorrect	Correct/ Incorrect
Proper Signal					
Lane Position					
Proper Speed					
Correct Turning Radius					
Look Through Turn					
Straighten Wheels					

Right Turns:

Procedure	Correct/ Incorrect	Correct/ Incorrect	Correct/ Incorrect	Correct/ Incorrect	Correct/ Incorrect
Proper Signal					
Lane Position					
Proper Speed					
Correct Turning Radius					
Look Through Turn					
Straighten Wheels					

Stop Signs:

Procedure	Correct/ Incorrect	Correct/ Incorrect	Correct/ Incorrect	Correct/ Incorrect	Correct/ Incorrect
Mirror Check on Approach					
Slow Speed					
Correct Stopping Point					
Complete Stop					
Search Left and Right Before Proceeding					
Uses Second Glance					

Three-Point Turns:

Procedure	Correct/ Incorrect	Correct/ Incorrect	Correct/ Incorrect	Correct/ Incorrect	Correct/ Incorrect
Right Signal to Pull Out of Traffic					
Park About 12" from Curb					
Signal Left					
Check Mirrors					
Check Blind Spot					
Complete Turn Without Hitting Curb					

Comments:

Checklist for Expressway Driving

Driver:

Observer:

Date:

Instructions: The observer uses this checklist to help the driver remember the procedures. The observer places a (check) on the space when the driver is correct. Place a (0) on the space if the driver forgets the action. Each vertical line of boxes represents one trial.

Entrances:

Procedure	Correct/ Incorrect	Correct/ Incorrect	Correct/ Incorrect	Correct/ Incorrect	Correct/ Incorrect
Visual Check from Ramp					
Left Signal					
Scan Expressway					
Accelerate to Expressway Speed					
Blind Spot Check					
Smooth Merge					
Cancel Signal					

Exits:

Procedure	Correct/ Incorrect	Correct/ Incorrect	Correct/ Incorrect	Correct/ Incorrect	Correct/ Incorrect
Check Mirror					
Right Signal					
Move into Deceleration Lane as soon as possible					
Decelerate in Deceleration Lane					
Proper Speed on Off-Ramp					

Lane changes:

Procedure	Correct/ Incorrect	Correct/ Incorrect	Correct/ Incorrect	Correct/ Incorrect	Correct/ Incorrect
Check Mirror					
Proper Signal					
Blind Spot Check					
Maintain Speed					
Smooth Lane Change					
Cancel Signal					

Timed Distance:

Sight, Stopping, Following

1. Estimated: Actual:
2. Estimated: Actual:
3. Estimated: Actual:
4. Estimated: Actual:
5. Estimated: Actual:
6. Estimated: Actual:
7. Estimated: Actual:
8. Estimated: Actual:
9. Estimated: Actual:
10. Estimated: Actual:

Comments:

Identification of Traffic Signs

Name:

Date:

Driving Environment:

Directions: Place a check on the appropriate box when a traffic sign is identified. Keep a running total. Put the total at the bottom.

Regulatory:

1.
2.
3.
4.
5.
6.
7.
8.
9.
10.
11.
12.
13.
14.
15.
16.
17.
18.
19.
20.
21.
22.
23.
24.
25.
26.
27.
28.
29.
30.
31.
32.

- 33.
- 34.
- 35.
- 36.
- 37.
- 38.
- 39.
- 40.
- 41.
- 42.
- 43.
- 44.
- 45.
- 46.
- 47.
- 48.
- 49.
- 50.
- 51.
- 52.
- 53.
- 54.
- 55.
- 56.
- 57.
- 58.
- 59.
- 60.
- 61.
- 62.
- 63.

Warning:

- 1.
- 2.
- 3.
- 4.
- 5.
- 6.

7.
8.
9.
10.
11.
12.
13.
14.
15.
16.
17.
18.
19.
20.
21.
22.
23.
24.
25.
26.
27.
28.
29.
30.
31.
32.
33.
34.
35.
36.
37.
38.
39.
40.
41.
42.
43.
44.
45.

- 46.
- 47.
- 48.
- 49.
- 50.
- 51.
- 52.
- 53.
- 54.
- 55.
- 56.
- 57.
- 58.
- 59.
- 60.
- 61.
- 62.
- 63.

Construction:

- 1.
- 2.
- 3.
- 4.
- 5.
- 6.
- 7.
- 8.
- 9.
- 10.
- 11.
- 12.
- 13.

Guide:

1.
2.
3.
4.
5.
6.
7.
8.
9.
10.
11.
12.
13.
14.
15.
16.
17.
18.
19.
20.
21.
22.
23.
24.
25.
26.
27.
28.
29.
30.
31.

Roadside Service:

1.
2.
3.
4.
5.
6.
7.
8.
9.
10.
11.
12.
13.
14.
15.
16.
17.
18.
19.
20.
21.
22.
23.
24.
25.
26.
27.
28.
29.
30.

Recreation Areas:

1.
2.
3.
4.
5.
6.
7.
8.
9.
10.
11.
12.
13.
14.

Route Markers:

PA Routes:

1.
2.
3.
4.
5.
6.
7.
8.
9.
10.

US Routes:

1.
2.
3.
4.
5.
6.
7.
8.

- 9.
- 10.

Interstate Routes:

- 1.
- 2.
- 3.
- 4.
- 5.
- 6.
- 7.
- 8.
- 9.
- 10.

Total Number of Signs Identified:

Appendix D

Student Performance Sheets for Selective Environments

Behind-the-Wheel Performance Objectives Driving Environment: Residential

Student Name:

Date:

S = Satisfactory

U = Unsatisfactory

1. Demonstrated the ability to maintain lane position at speeds up to 25 mph.
2. Ability to correctly identify intersections:
 - a. Uncontrolled
 - b. 2-way stop
 - c. 3-way stop
 - d. 4-way stop
3. Demonstrates ability to stop at appropriate point:
 - a. Before crosswalk
 - b. At intersection
 - c. Before sidewalk
 - d. At stop line
4. Ability to effectively scan and identify an open or blind intersection.
5. Effectively communicate with other drivers and pedestrians.
6. Correctly perform a 3-point and a 2-point turn.
7. Ability to make smooth starts and stops.

General Comments:

Recommendation:

- Student is cleared to proceed to next driving environment
- Student needs more practice in this environment
- No progress is being made, student should discontinue driving now.
- Student has completed driver training.

Behind-the-Wheel Performance Objectives

Driving Environment: Open Highway

Student Name:

Date:

S = Satisfactory

U = Unsatisfactory

1. Demonstrated the ability to maintain lane position at speeds from 25 - 55 mph.
2. Ability to use an orderly search pattern.
3. Ability to correctly identify, understand, and respond to traffic signs, signals, and roadway markings.
4. Ability to effectively scan and identify an open or blind intersection.
5. Effectively communicate with other drivers and pedestrians.
6. Ability to correctly identify and respond to changes in highway conditions:
 - a. Space
 - b. Visibility
 - c. Traction
7. Ability to make smooth starts and stops.
8. Ability to safely negotiate protected and unprotected turns.
9. Ability to safely negotiate hills and curves.
10. Demonstrate proper mirror usage.

General Comments:

Recommendation:

- Student is cleared to proceed to next driving environment
- Student needs more practice in this environment
- No progress is being made, student should discontinue driving now.
- Student has completed driver training.

Behind-the-Wheel Performance Objectives

Driving Environment: Moderate Traffic/Shopping Centers

Student Name:

Date:

S = Satisfactory

U =Unsatisfactory

1. Demonstrated the ability to maintain lane position at speeds from 35-45 mph.
2. Ability to use an orderly search pattern.
3. Ability to correctly identify, understand; and respond to traffic signs, signals, and roadway markings.
4. Ability to make safe and correct lane changes.
5. Efficiently communicate with other drivers and pedestrians.
6. Ability to correctly identify special turning lanes.
7. Ability to safely negotiate a busy shopping mall.
8. Ability to scan and identify an increased amount of driving hazards.
9. Ability to make smooth starts and stops.
10. Ability to safely negotiate protected and unprotected turns.
11. Ability to establish and maintain adequate space gaps.
12. Demonstrate proper mirror adjustments.

General Comments:

Recommendation:

- Student is cleared to proceed to next driving environment
- Student needs more practice in this environment
- No progress is being made, student should discontinue driving now.
- Student has completed driver training.

Behind-the-Wheel Performance Objectives Driving Environment: Expressway

Student Name:

Date:

S = Satisfactory

U =Unsatisfactory

Entrances:

1. Ability to identify the proper entrance.
2. Checks traffic with mirrors.
3. Signals and positions vehicle properly (on-ramp)
4. Adjusts speed appropriately.
5. Identifies a safe gap in traffic.
6. Signals and adjusts speed. (acceleration lane)
7. Check traffic ahead.
8. If weave lane, search for exiting traffic.
9. Merge smoothly and adjust speed.
10. Cancel signal

Expressway Driving:

1. Maintains proper speed for traffic flow.
2. Uses accelerator to adjust speed.
3. Identifies traffic controls.
4. Uses correct procedure for making lane changes.
5. Maintains a **minimum** 4-second following distance.
6. Effectively communicates with other drivers.
7. Estimates time and distance adequately.
8. Identifies merging traffic and makes lane changes as necessary.

Exits:

1. Identifies proper exit.
2. Checks mirrors.
3. Proper signal and lane selection.
4. Proper speed adjustment - **primarily** in deceleration lane; not on the main roadway.
5. Moves into deceleration lane as soon as possible.
6. Identify the recommended ramp speed.
7. Adjusts speed accordingly.
8. Check traffic ahead and behind when exiting.

General Comments:

Recommendation:

- Student is cleared to proceed to next driving environment
- Student needs more practice in this environment
- No progress is being made, student should discontinue driving now.
- Student has completed driver training.

Behind-the-Wheel Performance Objectives Driving Environment: Rural Roads

Student Name:

Date:

S = Satisfactory

U =Unsatisfactory

Ability to identify and respond to changes in:

1. Visibility.
2. Space.
3. Traction.
4. Side roads and driveways.
5. Actively search for animals.
6. Correctly respond to oncoming traffic.
7. Correctly respond to right wheels dropping off the road surface.
8. Identifying traffic controls.
9. Correct procedure for parking on an upgrade.
10. Correct procedure for parking on a downgrade.

General Comments:

Recommendation:

- Student is cleared to proceed to next driving environment
- Student needs more practice in this environment
- No progress is being made, student should discontinue driving now.
- Student has completed driver training.

Behind-the-Wheel Performance Objectives

Driving Environment: Vehicle Emergencies

Student Name:

Date:

S = Satisfactory

U = Unsatisfactory

Brake Failure:

1. Identify brake failure and simulate pumping the brake pedal.
2. Downshift to low gear.
3. Use emergency brake to stop the vehicle:

Emergency brake on floor:

- a. Pull brake release out with left hand.
- b. Keeping brake release out, use left foot to depress the emergency brake pedal.
- c. If brakes lock, release slight pressure to regain rolling traction. **Do not keep the brakes locked!**
- d. On vehicles with foot release, depress pedal quickly to release the lock mechanism, then modulate the pedal to stop the vehicle.

Emergency brake on console:

- a. Use right hand to grasp emergency brake handle and depress release button with thumb.
 - b. Pull handle up, keeping the button depressed.
 - c. If brakes lock, release slight pressure to regain rolling traction. **Do not keep the brakes locked!**
 - d. Modulate the emergency brake to stop the vehicle.
4. Search for and identify an appropriate place to stop the vehicle.

Behind-the-Wheel Performance Objectives Driving Environment: Central Business District

Student Name:

Date:

S = Satisfactory

U = Unsatisfactory

1. Ability to safely interact with a large volume of traffic.
2. Ability to safely change lanes when appropriate.
3. Ability to scan at least one block ahead of the projected path of travel.

Traffic Signals

4. Identify and respond to:
 - a. Signal lights.
 - b. Signal lights with directional arrows.
 - c. Advanced/delayed left turn signal with or without arrows.
 - d. Lane control arrows.
 - e. Flashing warning lights.
 - f. Railroad crossing lights.

Lane Markings

5. Identify and respond to:
 - a. Single solid yellow lines.
 - b. Single solid white lines.
 - c. Double solid yellow lines.
 - d. Broken yellow lines.
 - e. Broken white lines.
 - f. Solid white zebra lines.
 - g. Solid white arrows.
6. Identify special traffic concerns:
 - a. Taxis
 - b. Buses
 - c. Delivery trucks
 - d. Postal vehicles
 - e. Double parked vehicles
 - f. Bicycles
7. Identify and respond to pedestrians.
8. Identify and respond to areas of limited visibility.
9. Identify and respond to areas of reduced space.
10. Identify and respond to areas of reduced traction.
11. Correct parallel park procedure.
12. Ability to negotiate a parking garage.

13. Increased awareness and alertness in central business district.
14. Turn into correct lane when making left or right turn.
15. Selecting a safe gap in traffic:
 - a. Approach intersection and select a safe gap for crossing the intersection.
 - b. Check for pedestrians, bicyclists, oncoming and cross traffic.
 - c. Allow a larger gap in traffic when turning.

General Comments:

Recommendation:

- Student is cleared to proceed to next driving environment
- Student needs more practice in this environment
- No progress is being made, student should discontinue driving now.
- Student has completed driver training.

Behind-the-Wheel Performance Objectives Driving Environment: Night Driving

Student Name:

Date:

S = Satisfactory

U =Unsatisfactory

1. Ability to distinguish difference in visibility levels in different driving areas.
2. Ability to sight beyond the range of the headlights.
3. Ability to adjust speed to low light conditions.
4. Use of high/low beam headlights.
5. Dim headlights as soon as appropriate.
6. Maintains at least a 5 second following distance behind other vehicles.
7. Ability to track and maintain safe lane position.
8. Adjust inside mirror to night position if appropriate.
9. Ability to identify critical traffic controls in low light situation.
10. Effective communication with other highway users.

General Comments:

Recommendation:

- Student is cleared to proceed to next driving environment
- Student needs more practice in this environment
- No progress is being made, student should discontinue driving now.
- Student has completed driver training.